

SD5600/5610

Optoschmitt Detector

SCHEMATIC

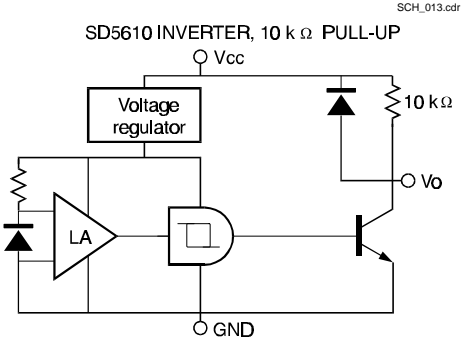

SWITCHING TIME TEST CIRCUIT

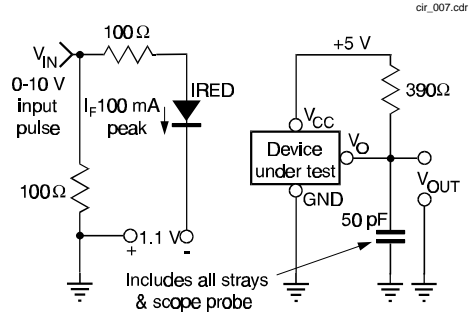

SWITCHING WAVEFORM FOR BUFFERS

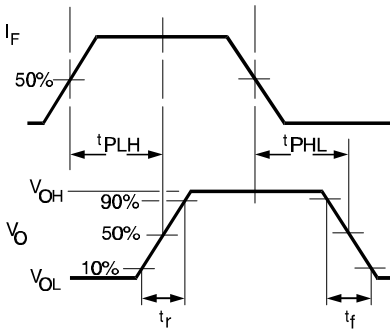
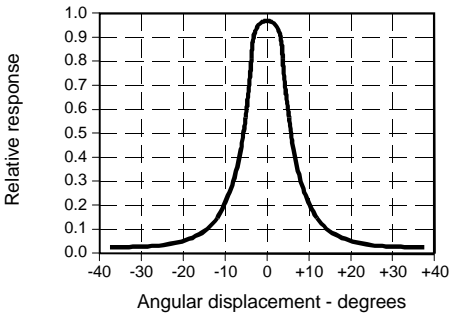

Fig. 1 Responsivity vs Angular Displacement



SWITCHING WAVEFORM FOR INVERTERS

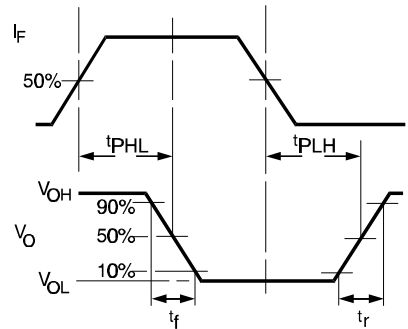
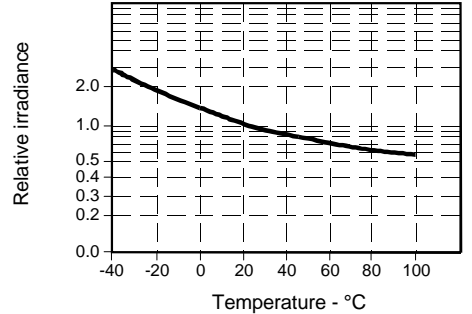

Fig. 2 Threshold Irradiance vs Temperature



SD5600/5610

Optoschmitt Detector

Fig. 3 Output Rise Time (t_r) and Output Fall Time (t_f) vs Temperature

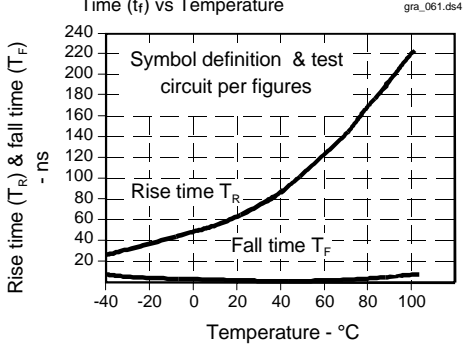

Fig. 4 Delay Time vs Temperature

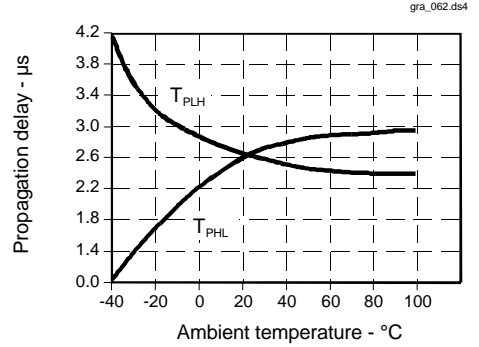
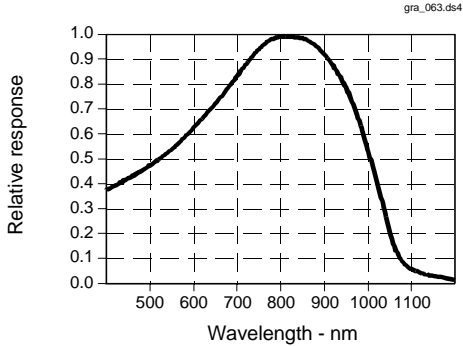

Fig. 5 Spectral Responsivity



All Performance Curves Show Typical Values