

# HLC2701

## Encoder Detector

### FUNCTIONAL BLOCK DIAGRAM

SCH\_045.cdr

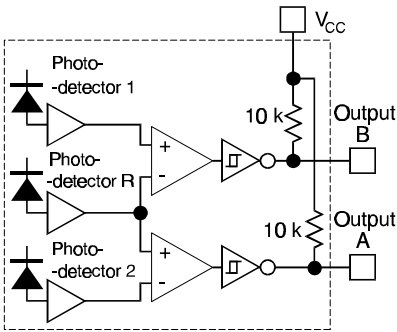

### SWITCHING WAVEFORM

cir\_011.cdr

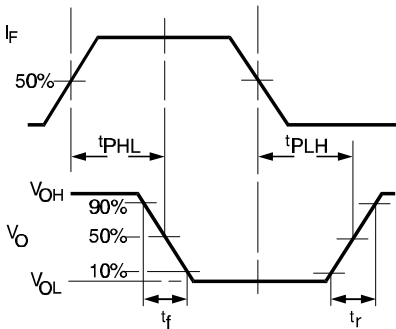
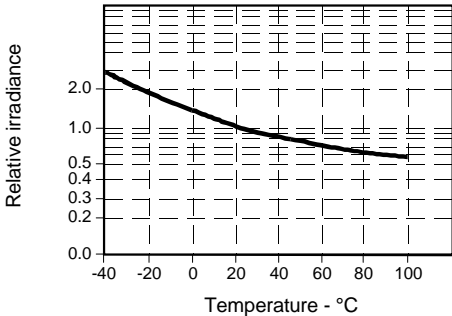

Fig. 2 Threshold Irradiance vs Temperature

gra\_060.ds4



### SWITCHING TIME TEST CIRCUIT

cir\_014.cdr

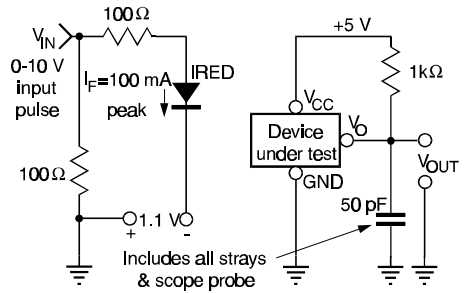

Fig. 1 Responsivity vs Angular Displacement

gra\_066.ds4

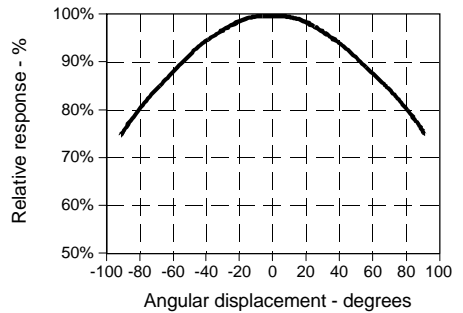
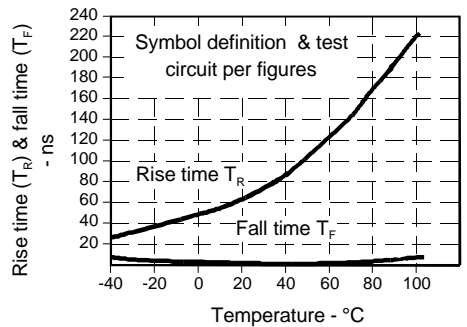

Fig. 3 Output Rise Time ( $t_r$ ) and Output Fall Time ( $t_f$ ) vs Temperature

gra\_061.ds4



# HLC2701

## Encoder Detector

Fig. 4 Delay Time vs Temperature

gra\_062.ds4

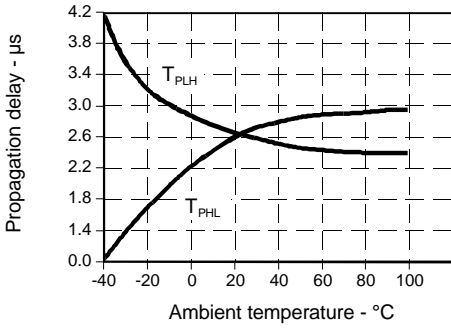
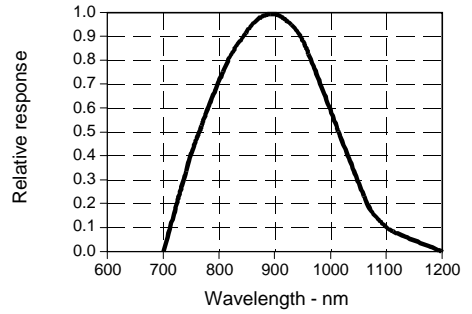

Fig. 5 Spectral Responsivity

gra\_050.ds4



All Performance Curves Show Typical Values