

Part no.
Article no.

DILM300/22(RA250)
208205

Delivery programme

Product range			Contactors
Application			Contactors for Motors
Subrange			Comfort devices greater than 150 A
Utilization category			AC-1: Non-inductive or slightly inductive loads, resistance furnaces AC-3: Squirrel-cage motors: starting, switching off during running AC-4: Squirrel-cage motors: starting, plugging, reversing, inching
Connection technique			Screw terminals
Rated operational current			
AC-3			
380 V 400 V	I_e	A	300
AC-1			
Conventional free air thermal current, 3 pole, 50 - 60 Hz			
Open			
at 40 °C	$I_{th} = I_e$	A	490
enclosed	I_{th}	A	350
Conventional free air thermal current, 1 pole			
open	I_{th}	A	1000
enclosed	I_{th}	A	875
Max. rating for three-phase motors, 50 - 60 Hz			
AC-3			
220 V 230 V			
220 V 230 V	P	kW	90
380 V 400 V			
380 V 400 V	P	kW	160
660 V 690 V			
660 V 690 V	P	kW	286
1000 V	P	kW	132
AC-4			
220 V 230 V			
230 V	P	kW	75
380 V 400 V			
400 V	P	kW	132
660 V 690 V			
690 V	P	kW	229
1000 V	P	kW	132
Contact sequence			
Actuating voltage			RA 250: 110-250 V 40-60 Hz/110-250 V DC
Voltage AC/DC			AC operation
Auxiliary contacts			
possible variants at auxiliary contact module fitting options			on the side: 2 x DILM820-XHI11(V)-SI; 2 x DILM820-XHI11-SA
Side mounting auxiliary contacts			
Instructions			integrated suppressor circuit in actuating electronics 660 V, 690 V or 1000 V: not directly reversing

Note concerning the product

Classical

A1/A2 are attached to power supply as normal

Direct from the PLC

A 3 V output from the PLC can be directly connected to the

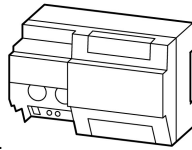

connections A4/A24.

From a low-power actuating device

Low-power actuating devices such as PCB relays, actuating devices or position switches can be directly connected to A10/A11.

DILM185A, DILM225A

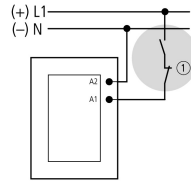

DILM250 to DILM1000, DILH1400

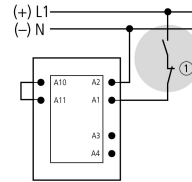

DILM1600, DILH2000, DILH2600

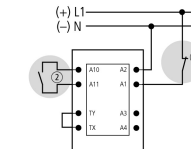
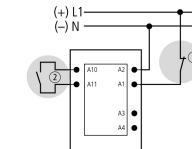
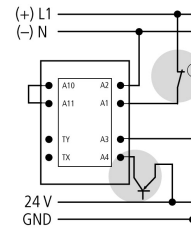
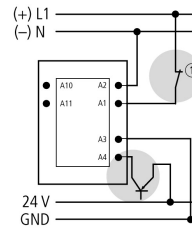
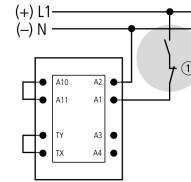

1 Stopping in the event of an emergency (emergency switching off)

2 Max. capacity 6 nF

Notes

When operating contactors DILM580 to DILM1600 with frequency inverter, the suppressor circuit on the load side must be removed.

During a high voltage test for the contactors DILM580 to DILH2600 the suppressor circuit on the load side must be removed.

Control voltages

RA250 110 V - 250 V AC/DC

RAW250 230 V - 250 V AC/DC

Approvals

Product Standards
UL File No.
UL CCN
CSA File No.
CSA Class No.
NA Certification
Specially designed for NA

IEC/EN 60947-4-1; UL 508; CSA-C22.2 No. 14-05; CE marking
E29096
NLDX
012528
3211-04
UL listed, CSA certified
No

General

Standards			IEC/EN 60947, VDE 0660, UL, CSA
Lifespan, mechanical			
AC operated	Operations	x 10 ⁶	10
DC operated	Operations	x 10 ⁶	10
Operating frequency, mechanical			
AC operated	Operations/h		3000
DC operated	Operations/h		3000
Climatic proofing			Damp heat, constant to IEC 60068-2-78 Damp heat, cyclic to IEC 60068-2-30
Ambient temperature		°C	
Open		°C	- 25 - 60
Enclosed		°C	- 25 - 40
Storage		°C	- 40 - 80

Mounting position			
Mounting position, AC- and DC operated			
Mechanical shock resistance (IEC/EN 60068-2-27)			
Half-sinusoidal shock, 10 ms			
Main contacts			
N/O contact		g	10
Auxiliary contacts			
N/O contact		g	10
N/C contact		g	8
Protection type			IP00
Protection against direct contact when actuated from front (EN 50274)			finger and back-of-hand proof with terminal shroud or terminal block
Weight			
AC operated		kg	8
DC operated		kg	8
Weight		kg	8
Terminal capacity main cable			
Flexible with cable lug		mm ²	50 - 240
Stranded with cable lug		mm ²	70 - 240
Solid or stranded		AWG	2/0 - 500 MCM
Flat conductor	Number of segments x width x thickness	mm	Fixing with flat cable terminal or cable terminal blocks See terminal capacity for cable terminal blocks
Busbar	Width	mm	25
Main cable connection screw/bolt			M10
Tightening torque		Nm	24
Terminal capacity control circuit cables			
Solid		mm ²	1 x (0.75 - 2.5) 2 x (0.75 - 2.5)
Flexible with ferrule		mm ²	1 x (0.75 - 2.5) 2 x (0.75 - 2.5)
Solid or stranded		AWG	2 x (18 - 12)
Control circuit cable connection screw/bolt			M3.5
Tightening torque		Nm	1.2
Tool			
Main cable			
Open-end spanner		mm	16
Control circuit cables			
Pozidriv screwdriver		Size	2
Main conducting paths			
Rated impulse withstand voltage	U _{imp}	V AC	8000

Overvoltage category/pollution degree			III/3
Rated insulation voltage			
AC	U_i	V AC	1000
Rated operational voltage	U_e	V AC	1000
Safe isolation to VDE 0106 Part 101 and Part 101/A1			
between coil and contacts		V AC	500
between the contacts		V AC	500
Making capacity (p.f. to IEC/EN 60947)		A	5500
Breaking capacity			
220 V 230 V		A	5000
380 V 400 V AC		A	5000
500 V		A	5000
660 690 V AC		A	5000
1000 V		A	950
Short-circuit rating			
Short-circuit protection maximum fuse			
Type "2" coordination			
400 V	gG/gL 500 V	A	500
690 V	gG/gL 690 V	A	500
1000 V	gG/gL 1000 V	A	200
Type "1" coordination			
400 V	gG/gL 500 V	A	630
690 V	gG/gL 690 V	A	630
1000 V	gG/gL 1000 V	A	250

AC

AC-1			
Rated operational current			
Conventional free air thermal current, 3 pole, 50 - 60 Hz			
Open			
at 40 °C	$I_{th} = I_e$	A	490
at 50 °C	$I_{th} = I_e$	A	438
at 55 °C	$I_{th} = I_e$	A	418
at 60 °C	$I_{th} = I_e$	A	400
enclosed	I_{th}	A	350
Conventional free air thermal current, 1 pole			
open	I_{th}	A	1000
enclosed	I_{th}	A	875
AC-3			
Rated operational current			
Open, 3-pole: 50 – 60 Hz			
220 V 230 V	I_e	A	300
240 V	I_e	A	300
380 V 400 V	I_e	A	300
415 V	I_e	A	300
440V	I_e	A	300
500 V	I_e	A	300
660 V 690 V	I_e	A	300
1000 V	I_e	A	95

Motor rating	P	kWh	
220 V 230 V	P	kW	90
240V	P	kW	100
380 V 400 V	P	kW	160
415 V	P	kW	180
440 V	P	kW	160
500 V	P	kW	215
660 V 690 V	P	kW	286
1000 V	P	kW	132
AC-4			
Open, 3-pole: 50 – 60 Hz			
230 V	I _e	A	240
240 V	I _e	A	240
400 V	I _e	A	240
415 V	I _e	A	240
440 V	I _e	A	240
500 V	I _e	A	240
690 V	I _e	A	240
1000 V	I _e	A	95
Motor rating	P	kWh	
230 V	P	kW	75
240 V	P	kW	82
400 V	P	kW	132
415 V	P	kW	142
440 V	P	kW	140
500 V	P	kW	172
690 V	P	kW	229
1000 V	P	kW	132

Condensator operation

Individual compensation, rated operational current I _e of three-phase capacitors			
open			
up to 525 V		A	307
690 V		A	177
Max. inrush current peak		x I _e	30
Component lifespan	Operations	x 10 ⁶	0.1
Max. operating frequency		Ops/h	200

DC

Rated operational current, open			
DC-1			
60 V	I _e	A	400
110 V	I _e	A	400
220 V	I _e	A	400
440 V	I _e	A	11
DC-3			
60 V	I _e	A	400
110 V	I _e	A	400
220 V	I _e	A	400
DC-5			
60 V	I _e	A	400
110 V	I _e	A	400
220 V	I _e	A	400

Current heat loss

3-pole at I_{th}		W	37
Current heat loss at I_e to AC-3/400 V		W	21
Magnet systems			
Voltage tolerance		$x U_c$	
U_c			110 - 250 V 40-60 Hz 110 - 250 V DC
AC operated	Pick-up	$x U_c$	
	Pick-up	$x U_c$	$0.7 \times U_{c \min} - 1.15 \times U_{c \max}$
DC operated	Pick-up	$x U_c$	
	Pick-up	$x U_c$	$0.7 \times U_{c \min} - 1.15 \times U_{c \max}$
Drop-out voltage AC operated	Drop-out	$x U_c$	
	Drop-out	$x U_c$	$0.2 \times U_{c \min} - 0.6 \times U_{c \max}$
DC operated	Drop-out	$x U_c$	
	Drop-out	$x U_c$	$0.2 \times U_{c \min} - 0.6 \times U_{c \max}$
Power consumption of the coil in a cold state and $1.0 \times U_c$			
50 Hz	Pick-up	VA	450
AC operated	Pick-up	W	350
60 Hz	Pick-up	VA	715
60 Hz	Pick-up	W	645
Dual-frequency coil 50/60 Hz at 50 Hz	Sealing	VA	4.3
Dual-frequency coil 50/60 Hz at 50 Hz	Sealing	W	3.3
Dual-frequency coil 50/60 Hz at 60 Hz	Sealing	VA	4.3
Dual-frequency coil 50/60 Hz at 60 Hz	Sealing	W	3.3
Duty factor		% DF	100
Switching times at 100 % U_c (approximate values)			
Main contacts			
AC operated			
	Closing delay	ms	80
	Opening delay	ms	80
DC operated			
	Closing delay	ms	50
	Opening delay	ms	40
Behaviour in marginal and transitional conditions			
Sealing			
Voltage interruptions			
	$(0 \dots 0.2 \times U_{c \min}) \overset{\text{ms}}{\text{ms}}$		Time is bridged successfully
	$(0 \dots 0.2 \times U_{c \min}) > 10 \text{ ms}$		Drop-out of the contactor
Voltage drops			
	$(0.2 \dots 0.6 \times U_{c \min}) \overset{\text{ms}}{\text{ms}}$		Time is bridged successfully
	$(0.2 \dots 0.6 \times U_{c \min}) > 12 \text{ ms}$		Drop-out of the contactor
	$(0.6 \dots 0.7 \times U_{c \min})$		Contactor remains switched on
Excess voltage			
	$(1.15 \dots 1.3 \times U_{c \max})$		Contactor remains switched on
	$(> 1.3 \times U_{c \max}) \overset{\text{s}}{\text{s}}$		Contactor remains switched on
	$(> 1.3 \times U_{c \max}) > 3 \text{ s}$		Drop-out of the contactor
Pick-up phase			
	$(0 \dots 0.7 \times U_{c \min})$		Contactor does not switch on
	$(0.7 \times U_{c \min} \dots 1.15 \times U_{c \max})$		Contactor switches on with certainty
	$(> 1.15 \times U_{c \max})$		Contactor switches on with certainty
Admissible transitional contact resistance (of the external control circuit device when actuating A11)		m Ω	$\overset{\text{ms}}{\text{ms}}$ 500
PLC signal level (A3 - A4) to IEC/EN 61131-2 (type 2)			

High	V	15
Low	V	5
Electromagnetic compatibility (EMC)		
Electromagnetic compatibility		This product is designed for operation in industrial environments (environment 2). The use in residential environments (environment 1) could cause electrical interference so that addition suppression must be planned.

Technical data ETIM 4.0

Number of main contacts as N/Os		3
Rated operation current Ie at AC-1, 400 V		490
Connection type main circuit		Screw connection
Rated control voltage Us at AC 60HZ	V	250
Number of auxiliary contacts as N/Os		2
Rated control voltage Us at AC 50HZ	V	250
Number of auxiliary contacts as N/Cs		2
Suitable for rail-mounting		No
Rated control voltage Us at DC	V	250
Voltage type for actuation		AC/DC
Rated operation current Ie at AC-3, 400 V	A	300
Number of N/Cs as main contact		0
Motor rating at AC-3, 400 V	kWh	160

Characteristics

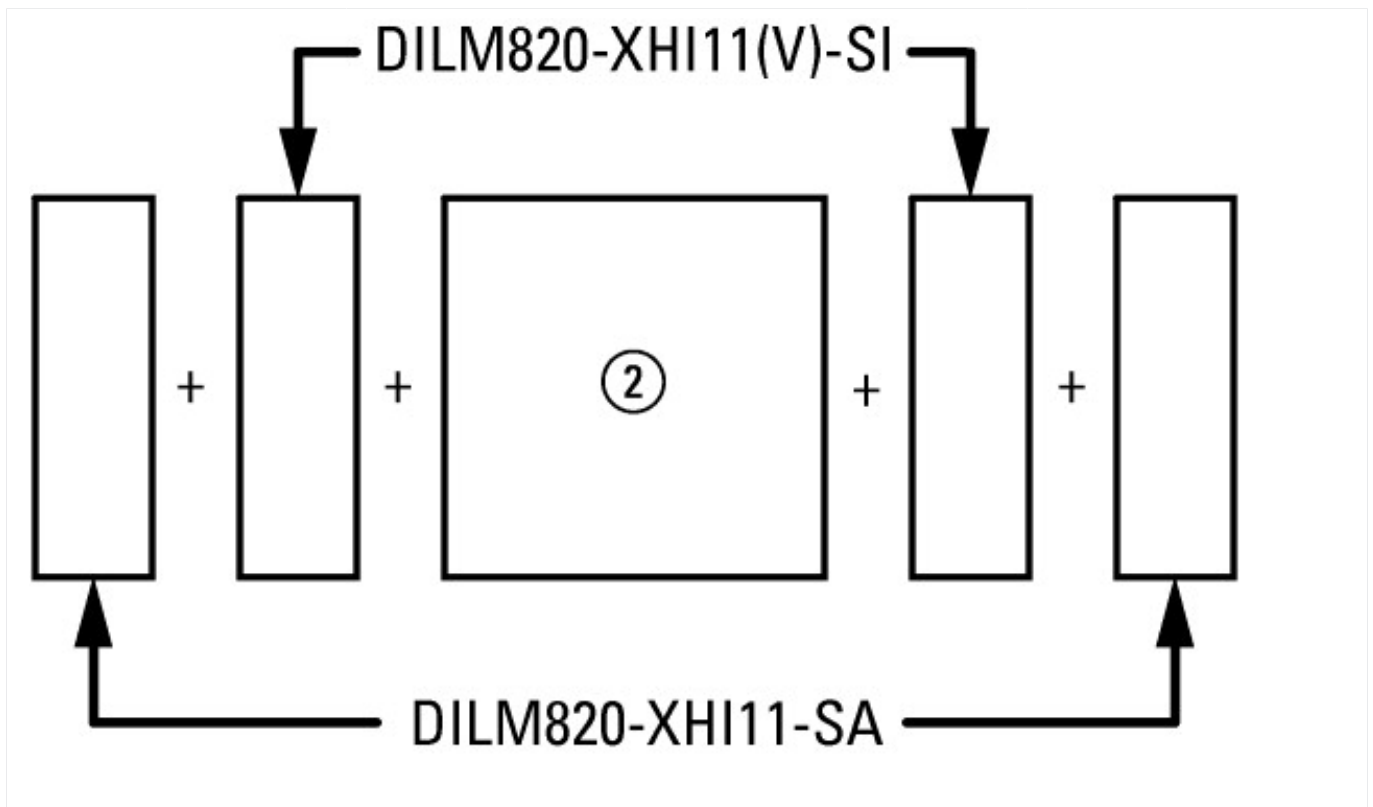

on the side: 2 x DILM820-XHI11(V)-SI; 2 x DILM820-XHI11-SA

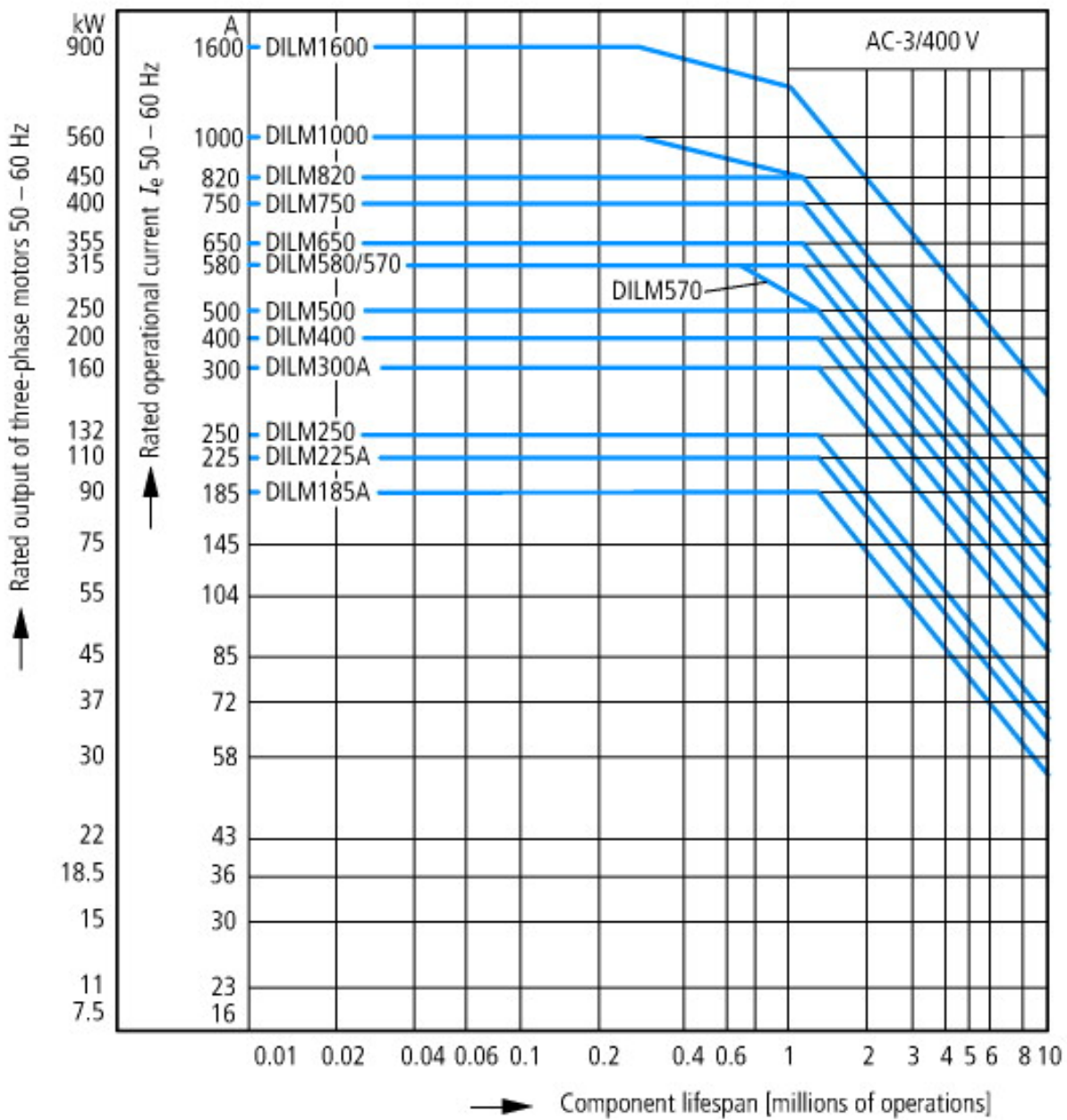

Squirrel-cage motor
 Operating characteristics
 Starting: from rest
 Stopping: after attaining full running speed
 Electrical characteristics
 Make: up to 6 x rated motor current
 Break: up to 1 x rated motor current
 Utilization category
 100 % AC-3
 Typical applications
 Compressors
 Lifts
 Mixers
 Pumps
 Escalators
 Agitators
 Fans
 Conveyor belts
 Centrifuges
 Hinged flaps
 Bucket-elevators
 Air conditioning system
 General drives in manufacturing and processing machines

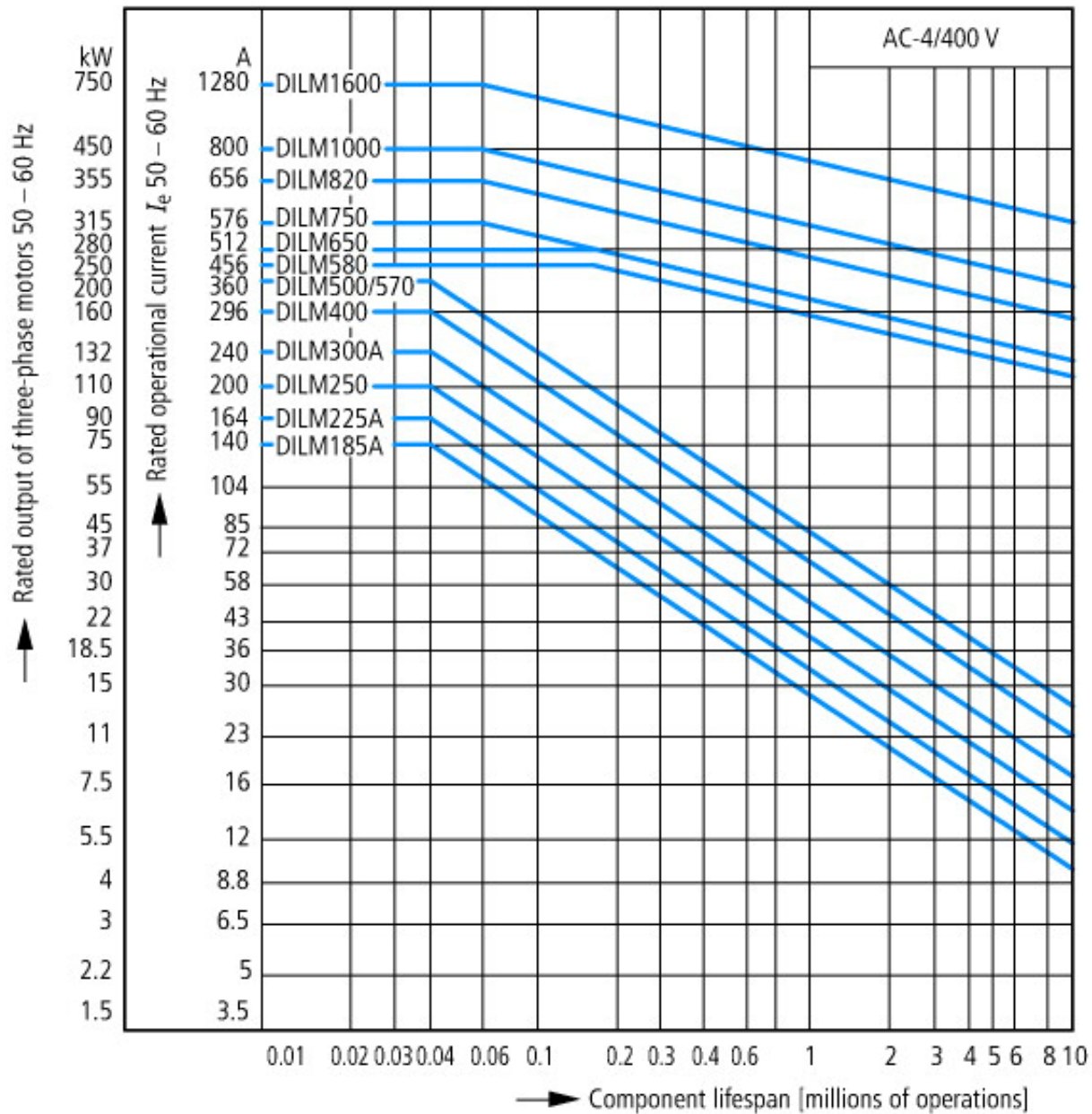

- Extreme switching duty
- Squirrel-cage motor
- Operating characteristics
- Inching, plugging, reversing
- Electrical characteristics
- Make: up to 6 x rated motor current
- Break: up to 6 x rated motor current
- Utilization category
- 100 % AC-4
- Typical applications
- Printing presses
- Wire-drawing machines
- Centrifuges
- Special drives for manufacturing and processing machines

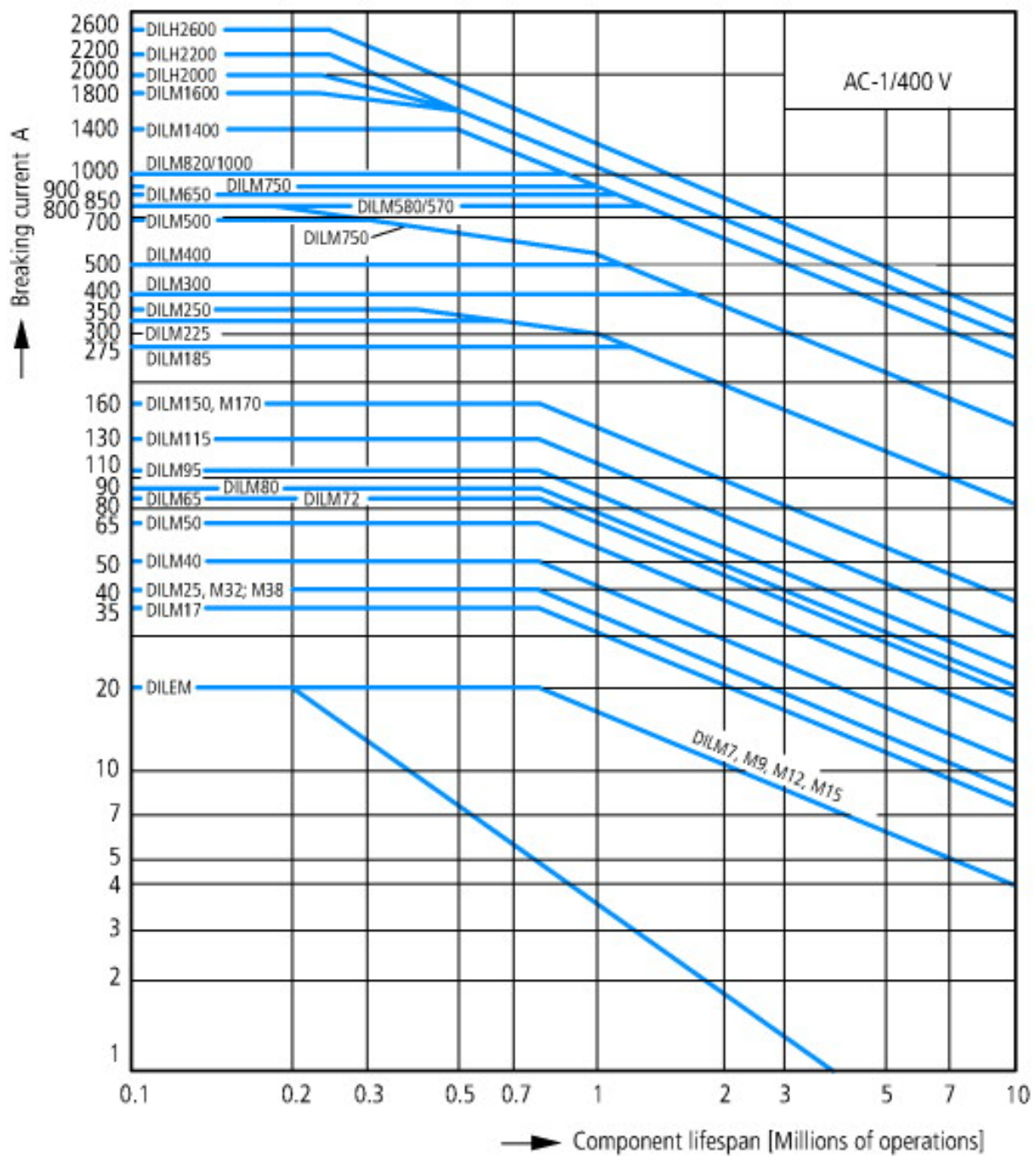

Switching duty for non-motor loads, 3-pole, 4-pole
 Operating characteristics
 Non-inductive or slightly inductive loads
 Electrical characteristics
 Make: 1 x rated current
 Break: 1 x rated current
 Utilization category
 100 % AC-1
 Typical applications
 Electric heat

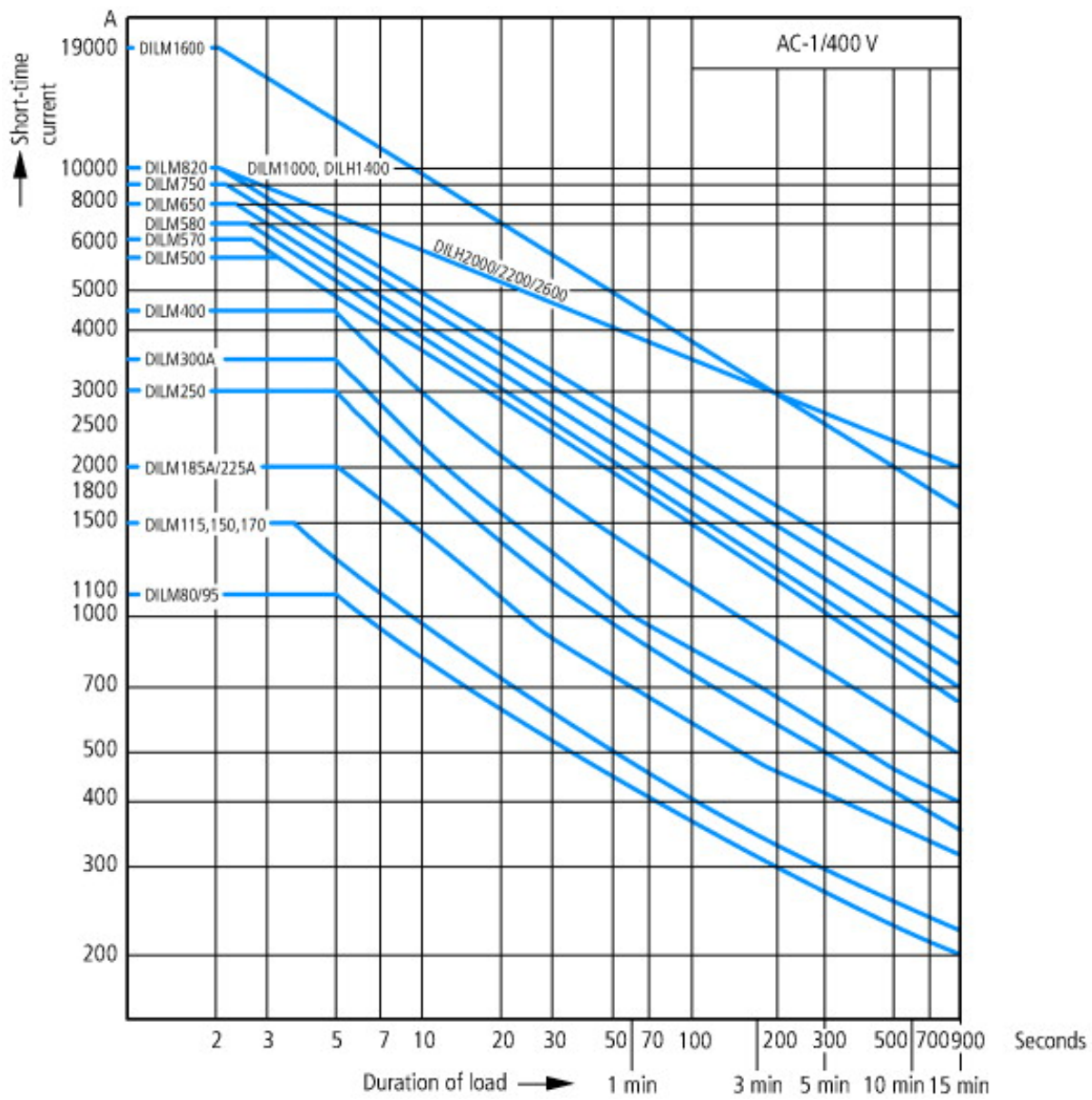

Short-time loading, 3-pole
Time interval between two loading cycles: 15 minutes

Normal switching duty

Dimensions

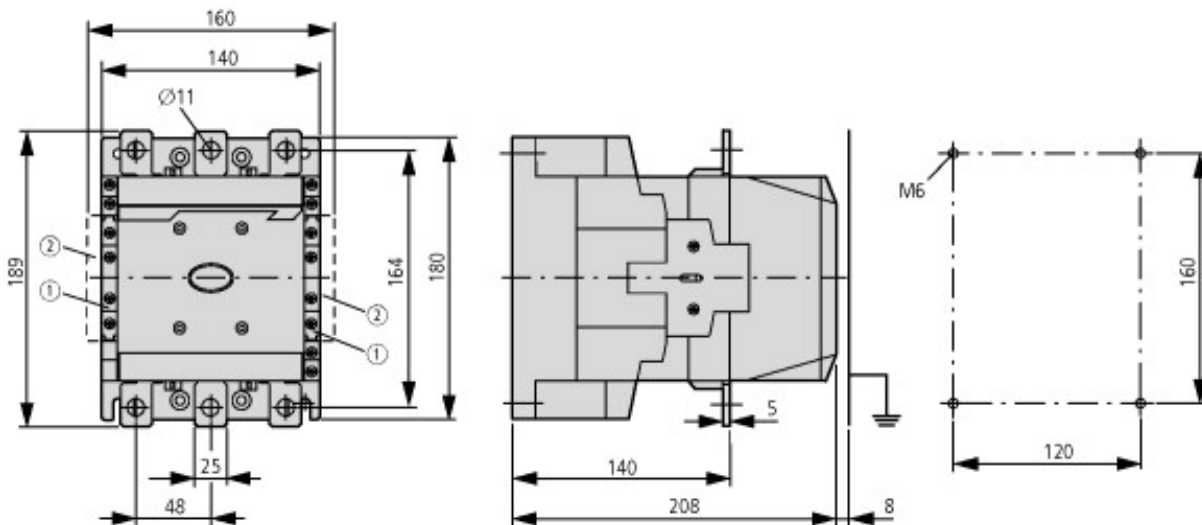

- ① DILM820-XHI11(V)-SI
- ② DILM820-XHI11-SA

Additional product information (links)

IL03406002Z (AWA2100-1639) Contactors >170 A

	IL03406002Z (AWA2100-1639) Contactors >170 A
	IL03406002Z (AWA2100-1639) Contactors >170 A
http://de.ecat.moeller.net/flip-cat/?edition=HPLTE&startpage=5.84	
http://de.ecat.moeller.net/flip-cat/?edition=HPLTE&startpage=5.86	
Switchgear of Power Factor Correction Systems	http://www.moeller.net/binary/ver_techpapers/ver934en.pdf
X-Start - Modern Switching Installations Efficiently Fitted and Wired Securely	http://www.moeller.net/binary/ver_techpapers/ver938en.pdf
Mirror Contacts for Highly-Reliable Information Relating to Safety-Related Control Functions	http://www.moeller.net/binary/ver_techpapers/ver944en.pdf
Effect of the Cable Capacitance of Long Control Cables on the Actuation of Contactors	http://www.moeller.net/binary/ver_techpapers/ver949en.pdf
Motor starters and "Special Purpose Ratings" for the North American market	http://www.moeller.net/binary/ver_techpapers/ver953en.pdf
Switchgear for Luminaires	http://www.moeller.net/binary/ver_techpapers/ver955en.pdf
Standard Compliant and Functionally Safe Engineering Design with Mechanical Auxiliary Contacts	http://www.moeller.net/binary/ver_techpapers/ver956en.pdf
The Interaction of Contactors with PLCs	http://www.moeller.net/binary/ver_techpapers/ver957en.pdf
Busbar Component Adapters for modern Industrial control panels	http://www.moeller.net/binary/ver_techpapers/ver960en.pdf