

# Models 7C, 7D, 7E & 7F

502.969.8000



## Models 7C, 7D, 7E & 7F

With their solid stainless steel housings and leverless limit switch design, Stroke to GO switches have set the standard for reliability and durability in cylinder position sensing.

### Features:

- SPDT 4A contacts
- Inherently Intrinsically Safe
- 40° to 221°F operating temperature

### Options:

- 40° to 400°F high temperature
- Quick disconnect connector
- Underwater capabilities



**FAST TRACK DELIVERY**

SPST	SPDT
<b>7C-23658-DCA</b> 1.025" Probe Mini Connector	<b>7C-43658-DCA</b> 1.025" Probe Mini Connector
<b>7D-23658-DCA</b> 1.250" probe Mini Connector	<b>7D-43658-DCA</b> 1.250" probe Mini Connector
<b>7E-23658-DCA</b> 2.062" probe Mini Connector	<b>7E-43658-DCA</b> 2.062" probe Mini Connector

# Leverless Limit Switches



Cylinder Position Sensors

## Dimensions

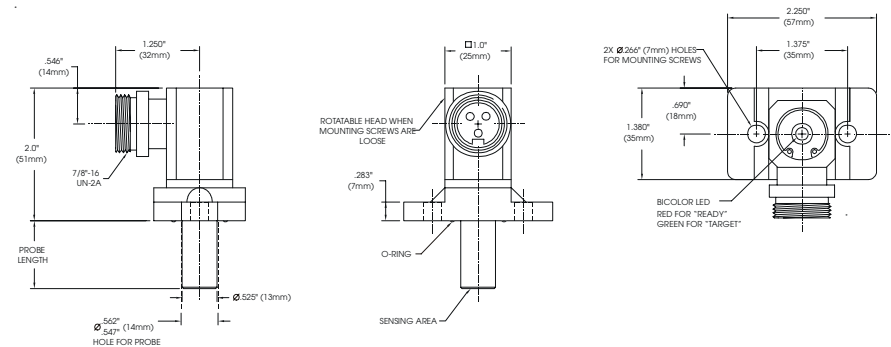

## Model

- Repeatability:** .002" (.05 mm) typical
- Response Time:** 8 milliseconds
- Differential:** Approx. .020" (.51 mm)
- Operating Temperature:** -40° to 160°F (-40° to 71°C) with LEDs -40° to 221°F (-40° to 105°C) without LEDs; HiTemp™ option to 400°F (204°C)

- 7C** Model 7C  
1.025" (26 mm) probe length
- 7D** Model 7D  
1.250" (32 mm) probe length
- 7E** Model 7E  
2.062" (52 mm) probe length
- 7F** Custom probe lengths  
1.000" (26 mm) - 5.000" (127 mm)\*

\*Probe lengths shorter than 1.000" require a taller upper switch housing

## Ordering Guide

Fill in the boxes to create your 'ordering number.'

## Contact Form

**Contact Material:** Palladium silver with sawtooth surface configuration

**Form:** SPDT, Form C (with or without LED indication) Single Pole, Single Throw (with or without LED indication) Form A or Form B

### Ratings: Resistive

Volts	AC		DC	
	Amperes	Watts	Amperes	Watts
120	4	24	3	3.6
240	2	48	1.5	18
480	1	120	0.75	45
600	0.75	90	0.5	33

- Without LED's
- With LED's
- 1** Single Pole Double Throw (Form C)
- 2** Single Pole Single Throw (Form A) (N/O output with bi-color LED indication) (Operating voltage: 24 - 120V AC/DC) (Optional voltage: 48 - 240V AC/DC) (Leakage current is 1.0mA)
- 3** Single Pole Single Throw (Form B) (N/C output with bi-color LED indication) (Operating voltage: 24 - 120V AC/DC) (Optional voltage: 48 - 240V AC/DC) (Leakage current is 1.0 mA)
- 4** Single Pole Double Throw (Form C) (without LED) (No leakage)
- 5** Single Pole Double Throw (Form C) (with dual LED's) (Operating voltage: 24 - 240V AC/DC) (No leakage current)
- 7** Single Pole Single Throw (Form A) (N/O output w/o LED indication; No leakage)
- 8** Single Pole Single Throw (Form B) (N/C output w/o LED indication; No leakage)

## Sensing Range

- Target Material:** Ferrous steel
- Sensing Range:** .090" (2.3 mm) end sensing (3,000 PSI) (Recommended air gap .015" - .040")
- 3** Standard sensing - approx. .090" (2.3 mm) end sensing

## Outlet Position

- 2** Side entry 360° adjustable (Wiring must be A, B, C, or F) No conduit hub
- 6** Side outlet 360° adjustable with Quick Disconnect (Wiring must be D) (Approval must be 7)
- 7** Side outlet 360° adjustable with 1/2" NPT conduit hub (Wiring must be A, B, or F)
- 8** Top outlet (Wiring must be SubSea)

### Need Accessories?

See pp. 93-104 for:  
Range Extending  
Target Magnets  
Mounting Brackets  
Connectors and more!

## Enclosure Material

- 5** Stainless Steel type 303  
Stainless steel (rated 3,000 PSI operating) (3 to 1 safety factor applies to standard probe lengths)

## Approvals

- 2** High temperature to 400°F (204°C) with Teflon™ insulated leads (Wiring must be F) (Contact form must be 4, 7, or 8)
- 7** CSA certified General Purpose
- 8** UL listed General Purpose

## Wiring Options

- Lead Wires** 18 Gauge (.110" dia) potted-in PVC insulated AWM / TEW stranded lead wires, rated at 221°F (105°C) 600V UL / CSA listed
  - A2** 36" (914 mm)
  - A3** 72" (1829 mm)
  - A4** 144" (3658 mm)
  - A\_ \_** Lengths greater than 144" (Specify length in feet (e.g. A150 = 150 ft. of leads))
- Cable** 18 Gauge (.250" dia.) potted-in PVC cable, rated at 176°F (80°C) 300V, UL / CSA listed
  - B2** 36" (914 mm)
  - B3** 72" (1829 mm)
  - B4** 144" (3658 mm)
  - B\_ \_** Lengths greater than 144" (Specify length in feet (e.g. B150 = 150 ft. of cable))
- Water Resistant** 18 Gauge (.250" dia.) PVC cable rated at 176°F (80°C) 300V with water-resistant squeeze connector.
  - C2** 36" (914 mm)
  - C3** 72" (1829 mm)
  - C4** 144" (3658 mm)
  - C\_ \_** Lengths greater than 144" (Specify length in feet (e.g. C150 = 150 ft. of cable))
- Quick Disconnect** Male Quick Disconnect only, potted-in connector. (CSA requires a case ground) (Approvals must be 7 or 8) Refer to pp. 93-104 for mating cable assemblies and Aura Light Adapters.
  - Mini-change®**
    - DCA** 3 - pin Mini-change® type
    - DCD** 4 - pin Mini-change® type
    - DCG** 5 - pin Mini-change® type
  - Micro-change®**
    - DBA** 3 - pin Micro-change® type
    - DBD** 4 - pin Micro-change® type
- SubSea Underwater Connector** (Outlet position must be 8)
  - 3DD** 3 pin, certified not to leak underwater
  - 4DD** 4 pin, certified not to leak underwater
  - 3DE** 3 pin right-angle, certified not to leak underwater
  - 4DE** 4 pin right-angle, certified not to leak underwater
- HiTemp Leads** 18 gauge (.070" dia. potted-in Teflon™ insulated leads rated at 482°F (250°C) 600V UL / CSA listed (Approval must be 2, 7, or 8)
  - F2** 36" (914 mm)
  - F3** 72" (1829 mm)
  - F4** 144" (3658 mm)
  - F\_ \_** Lengths greater than 144" (Specify length in feet (e.g. F150 = 150 ft. of leads))

Model

Contact Form

Sensing Range  
3

Outlet Position

Enclosure Material  
5

Approvals

Wiring Options

Cylinder Position Sensors

Stroke-To-GO® Switches provide precise end-of-stroke position indication on pneumatic and hydraulic cylinders. Designed to exceed automotive industry standards, the housing is machined from stainless steel bar stock to handle pressures to 3,000 PSI operating (tested to UL's 3X burst requirement) while withstanding the extreme external conditions such as weld slag, coolants, cutting fluids, physical abuse and even high temperatures. Stroke-to-GO® Switches incorporate the same 70 Series GO® Switch mechanism that has been tested to over 200 million mechanical cycles and field proven in the most rigorous applications. This unique design offers the greatest benefits in cylinder indication.

Unique Features

Mechanical life:

>200,000,000 cycles

Leakage current:

Without LEDs - none

With LEDs - <1mA (SPST)

Voltage Drop:

Without LEDs - none

SPDT w/ LEDs - 1.0 volt

With LEDs - 2.8 volts (SPST)

Temperature drift: none

**Washdown:** designed to withstand 1,000 PSI washdown and NEMA 6P with Mini-Change® type connector option

**Underwater:** rated to 10,000 PSI with deep sea connector option

**Weld Field Immune:** tested and exceeded General Motors EHS-320 specifications. Testing Agency - Candid Logic

**Radio Frequency Interference (RFI):** no affect at any frequency

Application Considerations

- Cylinder cushion must be ferrous.
- Air gap between switch sensing face and cushion should be .015" to .040" (outside this range please consult factory).
- Largest diameter of target (cushion) should cover at least 75% of probe sensing face.
- Sensing face of Stroke-To-GO® Switch must be at least .125" from piston rod for proper switch reset. This may at times require an air gap distance greater than .040".
- For cushion diameters less than .50", air gap should be .015" to .025".

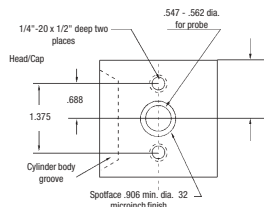

Leverless Limit Switches



A two digit code is required for ordering the correct custom probe length. All Application Considerations below must be met. For any discrepancies please consult factory. Please follow these steps:

1. Measure dimension A from both ends of your cylinder or retrieve from specification drawings.
2. Locate the Min/Max range that dimension A falls within on the Custom Probe Length Chart.
3. Locate probe length requirement and Probe Code in the next two Columns to the right.
4. Enter the probe code into the corresponding spaces of the Stroke-To-GO® Part Number.

Application Considerations

- Cylinder cushion must be ferrous.
- Air gap between switch sensing face and cushion should be .015" to .040" (outside this range please consult factory).
- Largest diameter of target (cushion) should cover at least 75% of probe sensing face.
- Sensing face of Stroke-To-GO® Switch must be at least .125" from piston rod for proper switch reset. This may at times require an air gap distance greater than .040".
- For cushion diameters less than .50", air gap should be .015" to .025".
- Mounting hardware is 1/4"-20 grade 8 socket head cap screw (included).

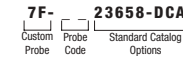

EXAMPLE: If "A" = 2.900" then:

"A"		PROBE LENGTH	PROBE CODE
MIN	MAX		
2.890	2.915	2.875	J4

Dimension A is measured from the outside surface of the cylinder block to the Top Dead Center (TDC) of the ferrous cushion. Distance A may differ at each end.

Probe Selection Chart

"A" RANGE				PROBE LENGTH	PROBE CODE	"A" RANGE				PROBE LENGTH	PROBE CODE
MIN	MAX	MIN	MAX			MIN	MAX	MIN	MAX		
1.015	1.040	1.000	A1	2.365	2.390	2.375	G2	3.715	3.740	3.700	N1
1.040	1.065	1.025	**	2.390	2.415	2.375	G2	3.740	3.765	3.725	N2
1.065	1.090	1.050	A3	2.415	2.440	2.400	G3	3.765	3.790	3.750	N3
1.090	1.115	1.075	A4	2.440	2.465	2.425	G4	3.790	3.815	3.775	N4
1.115	1.140	1.100	A5	2.465	2.490	2.450	G5	3.815	3.840	3.800	N5
1.140	1.165	1.125	A6	2.490	2.515	2.475	G6	3.840	3.865	3.825	N6
1.165	1.190	1.150	A7	2.515	2.540	2.500	G7	3.865	3.890	3.850	N7
1.190	1.215	1.175	A8	2.540	2.565	2.525	G8	3.890	3.915	3.875	N8
1.215	1.240	1.200	A9	2.565	2.590	2.550	G9	3.915	3.940	3.900	N9
1.240	1.265	1.225	B1	2.590	2.615	2.575	H1	3.940	3.965	3.925	P1
1.265	1.290	1.250	**	2.615	2.640	2.600	H2	3.965	3.990	3.950	P2
1.290	1.315	1.275	B3	2.640	2.665	2.625	H3	3.990	4.015	3.975	P3
1.315	1.340	1.300	B4	2.665	2.690	2.650	H4	4.015	4.040	4.000	P4
1.340	1.365	1.325	B5	2.690	2.715	2.675	H5	4.040	4.065	4.025	P5
1.365	1.390	1.350	B6	2.715	2.740	2.700	H6	4.065	4.090	4.050	P6
1.390	1.415	1.375	B7	2.740	2.765	2.725	H7	4.090	4.115	4.075	P7
1.415	1.440	1.400	B8	2.765	2.790	2.750	H8	4.115	4.140	4.100	P8
1.440	1.465	1.425	B9	2.790	2.815	2.775	H9	4.140	4.165	4.125	P9
1.465	1.490	1.450	C1	2.815	2.840	2.800	J1	4.165	4.190	4.150	R1
1.490	1.515	1.475	C2	2.840	2.865	2.825	J2	4.190	4.215	4.175	R2
1.515	1.540	1.500	C3	2.865	2.890	2.850	J3	4.215	4.240	4.200	R3
1.540	1.565	1.525	C4	2.890	2.915	2.875	J4	4.240	4.265	4.225	R4
1.565	1.590	1.550	C5	2.915	2.940	2.900	J5	4.265	4.290	4.250	R5
1.590	1.615	1.575	C6	2.940	2.965	2.925	J6	4.290	4.315	4.275	R6
1.615	1.640	1.600	C7	2.965	2.990	2.950	J7	4.315	4.340	4.300	R7
1.640	1.665	1.625	C8	2.990	3.015	2.975	J8	4.340	4.365	4.325	R8
1.665	1.690	1.650	C9	3.015	3.040	3.000	J9	4.365	4.390	4.350	R9
1.690	1.715	1.675	D1	3.040	3.065	3.025	K1	4.390	4.415	4.375	S1
1.715	1.740	1.700	D2	3.065	3.090	3.050	K2	4.415	4.440	4.400	S2
1.740	1.765	1.725	D3	3.090	3.115	3.075	K3	4.440	4.465	4.425	S3
1.765	1.790	1.750	D4	3.115	3.140	3.100	K4	4.465	4.490	4.450	S4
1.790	1.815	1.775	D5	3.140	3.165	3.125	K5	4.490	4.515	4.475	S5
1.815	1.840	1.800	D6	3.165	3.190	3.150	K6	4.515	4.540	4.500	S6
1.840	1.865	1.825	D7	3.190	3.215	3.175	K7	4.540	4.565	4.525	S7
1.865	1.890	1.850	D8	3.215	3.240	3.200	K8	4.565	4.590	4.550	S8
1.890	1.915	1.875	D9	3.240	3.265	3.225	K9	4.590	4.615	4.575	S9
1.915	1.940	1.900	E1	3.265	3.290	3.250	L1	4.615	4.640	4.600	T1
1.940	1.965	1.925	E2	3.290	3.315	3.275	L2	4.640	4.665	4.625	T2
1.965	1.990	1.950	E3	3.315	3.340	3.300	L3	4.665	4.690	4.650	T3
1.990	2.015	1.975	E4	3.340	3.365	3.325	L4	4.690	4.715	4.675	T4
2.015	2.040	2.000	E5	3.365	3.390	3.350	L5	4.715	4.740	4.700	T5
2.040	2.065	2.025	E6	3.390	3.415	3.375	L6	4.740	4.765	4.725	T6
2.065	2.090	2.050	E7	3.415	3.440	3.400	L7	4.765	4.790	4.750	T7
2.090	2.115	2.075	E8	3.440	3.465	3.425	L8	4.790	4.815	4.775	T8
2.115	2.140	2.100	E9	3.465	3.490	3.450	L9	4.815	4.840	4.800	T9
2.140	2.165	2.125	F1	3.490	3.515	3.475	M1	4.840	4.865	4.825	V1
2.165	2.190	2.150	F2	3.515	3.540	3.500	M2	4.865	4.890	4.850	V2
2.190	2.215	2.175	F3	3.540	3.565	3.525	M3	4.890	4.915	4.875	V3
2.215	2.240	2.200	F4	3.565	3.590	3.550	M4	4.915	4.940	4.900	V4
2.240	2.265	2.225	F5	3.590	3.615	3.575	M5	4.940	4.965	4.925	V5
2.265	2.290	2.250	F6	3.615	3.640	3.600	M6	4.965	4.990	4.950	V6
2.290	2.315	2.275	F7	3.640	3.665	3.625	M7	4.990	5.015	4.975	V7
2.315	2.340	2.300	F8	3.665	3.690	3.650	M8	5.015	5.040	5.000	V8
2.340	2.365	2.325	F9	3.690	3.715	3.675	M9				

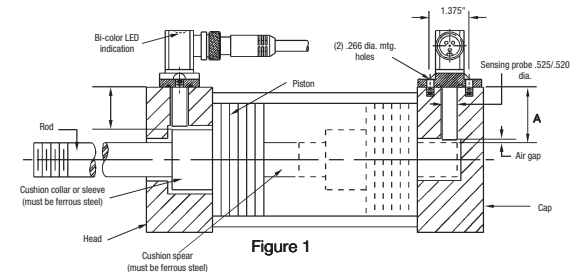

## Agency Approvals

Approvals	(2) HiTemp	(7) CSA General Purpose	(8) UL General Purpose
<b>Termination Options</b>			
A - Potted PVC Leads		X	X
B - Potted PVC Cable		X	X
C - Water squeeze connector		X	X
D - Quick Disconnect		X	X
D - SubSea™ Connector		X	X
F - HiTemp™ Leads	X	X	X

X = Approvals Available

## NEMA Ratings

Models 7C, 7D, 7E, 7F	Non-Hazardous				Hazardous	
NEMA CLASSES	4	4X	6	6P	7	9
A - Potted PVC leads	X	X				
B - Potted PVC cable	X	X				
C - PVC Cable w/ squeeze	X	X	X	X		
D - Quick Disconnect	X	X	X	X		
D - SubSea™ Connector	X	X	X	X		
F - HiTemp™ Teflon leads	X	X				

X = Designed to meet respective NEMA specifications

# Leverless Limit Switches



Cylinder Position Sensors

CONTACT FORMS		Leads		Cable		Water-Resistant		HiTemp
		UL	CSA	UL	CSA	UL	CSA	
2 - SPST Form A	COM	Black	Black	Black	Black	Black	Black	
	N/O	Blue	Blue	White	White	White	White	N/A
	N/O w/ LED	GND	Green	Red	Red	Red	Red	
3 - SPST Form B	COM	Black	Black	Black	Black	Black	Black	
	N/C	Red	Red	Red	Red	Red	Red	N/A
	N/C w/ LED	GND	Green	White	White	White	White	
4 - SPDT Form C	COM	Black	Black	Black	Black	Black	Black	Black
	N/O	Blue	Blue	White	White	White	White	Blue
	N/C	Red	Red	Red	Red	Red	Red	Red
	No LED	GND	Green	Green	Green	Green	Green	Green
5 - SPDT Form C	COM	Black	Black	Black	Black	Black	Black	
	N/O	Blue	Blue	White	White	White	White	N/A
	N/C	Red	Red	Red	Red	Red	Red	
Dual LEDs	GND	Green	Green	Green	Green	Green	Green	
7 - SPST Form A	COM	Black	Black	Black	Black	Black	Black	Black
	N/O	Blue	Blue	White	White	White	White	Blue
	N/O w/o LED	GND	Green	Red	Red	Red	Red	Green
8 - SPST Form B	COM	Black	Black	Black	Black	Black	Black	Black
	N/C	Red	Red	Red	Red	Red	Red	Red
	N/O w/o LED	GND	Green	Green	White	White	White	Green

### 3 Pin Micro Change with or without LED

SPST, Form A, N/O	
PIN 1	GND
PIN 2	COM
PIN 3	N/O

SPST, Form B, N/C	
PIN 1	GND
PIN 2	COM
PIN 3	N/C

SPDT, Form C	
PIN 1	COM
PIN 2	N/C
PIN 3	N/O

### 4 Pin Micro Change with or without LED

SPST, Form A, N/O	
PIN 1	COM
PIN 2	N/O
PIN 3	INACTIVE
PIN 4	GND

SPST, Form B, N/C	
PIN 1	COM
PIN 2	INACTIVE
PIN 3	N/C
PIN 4	GND

SPDT, Form C	
PIN 1	COM
PIN 2	N/O
PIN 3	N/C
PIN 4	GND

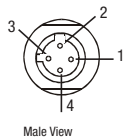
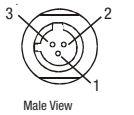

## Stroke to GO Wiring

502.969.8000

### 3 Pin Mini Change with or without LED

SPST, Form A, N/O	
PIN 1	GND
PIN 2	COM
PIN 3	N/O
SPST, Form B, N/C	
PIN 1	GND
PIN 2	COM
PIN 3	N/C
SPDT, Form C	
PIN 1	COM
PIN 2	N/C
PIN 3	N/O

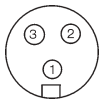

Male View

### 4 Pin Mini Change with or without LED

SPST, Form A, N/O	
PIN 1	COM
PIN 2	N/O
PIN 3	INACTIVE
PIN 4	GND
SPST, Form B, N/C	
PIN 1	COM
PIN 2	INACTIVE
PIN 3	N/C
PIN 4	GND
SPDT, Form C	
PIN 1	COM
PIN 2	N/O
PIN 3	N/C
PIN 4	GND

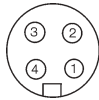

Male View

### 5 Pin Mini Change with or without LED

SPST, Form A, N/O	
PIN 1	N/O
PIN 2	Inactive
PIN 3	GND
PIN 4	Inactive
PIN 5	COM
SPST, Form B, N/C	
PIN 1	Inactive
PIN 2	N/C
PIN 3	GND
PIN 4	Inactive
PIN 5	COM
SPDT, Form C	
PIN 1	N/O
PIN 2	N/C
PIN 3	GND
PIN 4	Inactive
PIN 5	COM

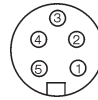

Male View

## Leverless Limit Switches



### 3 Pin SubSea without LED

SPST, Form A, N/O	
PIN 1	COM
PIN 2	N/O
PIN 3	GND
SPST, Form B, N/C	
PIN 1	COM
PIN 2	N/C
PIN 3	GND
SPDT, Form C	
PIN 1	N/C
PIN 2	COM
PIN 3	N/O

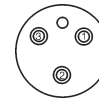

Male View

### 4 Pin SubSea without LED

SPST, Form A, N/O	
PIN 1	COM
PIN 2	N/O
PIN 3	INACTIVE
PIN 4	GND
SPST, Form B, N/C	
PIN 1	COM
PIN 2	INACTIVE
PIN 3	N/C
PIN 4	GND
SPDT, Form C	
PIN 1	COM
PIN 2	N/O
PIN 3	N/C
PIN 4	GND

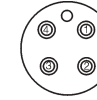

Male View

### 3 Pin SubSea - Right Angle without LED

SPST, Form A, N/O	
PIN 1	COM
PIN 2	N/O
PIN 3	GND
SPST, Form B, N/C	
PIN 1	COM
PIN 2	N/C
PIN 3	GND
SPDT, Form C	
PIN 1	COM
PIN 2	N/O
PIN 3	N/C



Male View

Cylinder Position Sensors