

# Industrial Control Relays, Electronic Timing Relays System Overview

DIL R

Industrial Control Relays  
Electronic Timing Relays

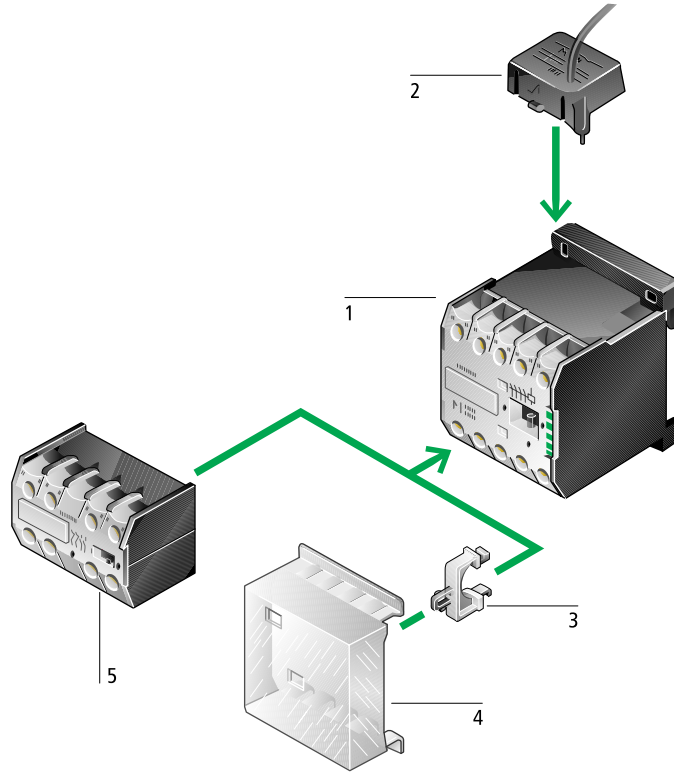

DIL R

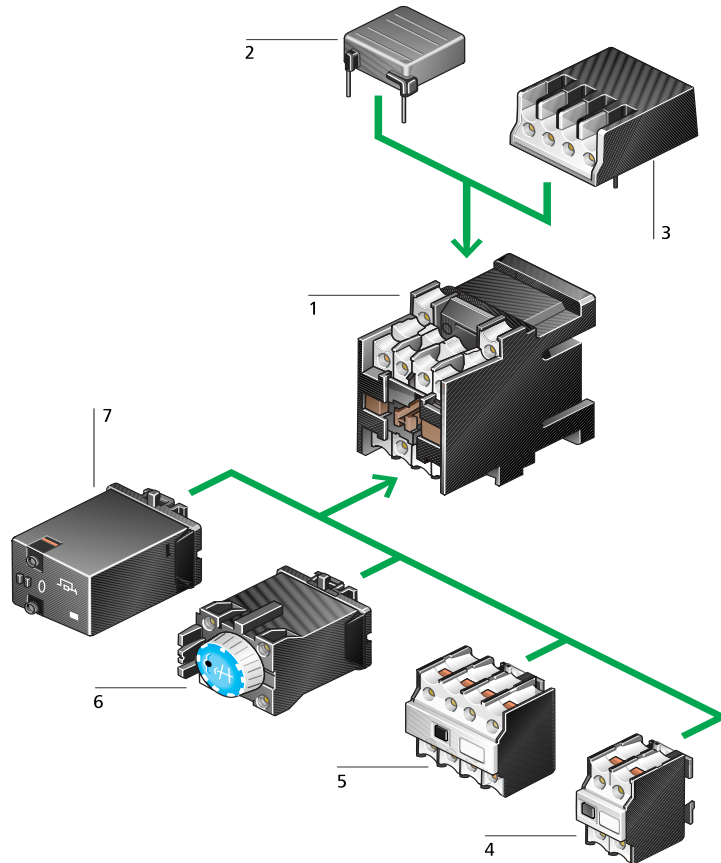

# Industrial Control Relays, Electronic Timing Relays System Overview

## DIL ER Industrial Control Relays

### Basic devices 1

World-wide approvals: UL, CSA, IEC/EN 60 947, CE
AC and DC operated versions
Maximum number of contacts: 8
Pilot duty: A 600 / P 300
Positively driven contacts to ZH 1/457 (N.O. and N.C. contacts can never be closed simultaneously)
Modular system of accessories and contacts
DIN rail or panel mounted
Finger-safe design
Captive, self-lifting screw clamp terminals
→ Page 02/010

### Suppressors 2

All industrial control relays with DC operated coils have an integral suppressor circuit
Suppressors for industrial control relays with AC operated coils
→ Page 02/024

### Tamper-proof cover 3, 4

Snap-fitting onto device
Can be sealed to prevent tampering
→ Page 02/025

### Auxiliary contact modules 5

Available in 2 and 4 pole versions
Pilot duty: A 600 / P 300
Positively driven contacts to ZH 1/457 (N.O. and N.C. contacts can never be closed simultaneously)
Overlapping contacts
Finger-safe design
Captive, self-lifting screw clamp terminals
→ Page 02/010

## DIL R Industrial Control Relays

### Basic device 1

World-wide approvals: UL, CSA, IEC/EN 60 947, CE
AC and DC operated versions
Coils available in special voltages
Maximum number of contacts: 8
Pilot duty: A 600 / P 300
Positively driven contacts to ZH 1/457 (N.O. and N.C. contacts can never be closed simultaneously)
Modular system of accessories and contacts
DIN rail or panel mounted
Finger-safe design
Captive, self-lifting screw clamp terminal
→ Page 02/012

### Suppressors 2

FC suppressor
Varistor suppressor
Free-wheel diode suppressor
→ Page 02/024

### Interface module 3

Used to energize coils from low level 24V DC power source
With or without built-in surge suppressor
Custom plug-fit into coil terminals
Individually mounted module available
→ Page 02/024

### Auxiliary contact modules 4, 5

Available in 2 and 4 pole versions
Pilot duty: A 600 / P 300
Positively driven contacts to ZH 1/457 (N.O. and N.C. contacts can never be closed simultaneously)
Overlapping contacts
Finger-safe design
Captive, self-lifting screw clamp terminal
→ Page 02/012

### Pneumatic timer modules 6















Available in ON-delay and OFF-delay versions
1 N.O. and 1 N.C. timed contacts
Each with 2 timing ranges, convertible from: 0.2 - 30 sec. to 20 - 180 sec.
→ Page 02/012

### Mechanical latching module 7

To maintain energized position of contacts in the event of a power loss to the relay coil
→ Page 02/012

**DILER Industrial Control Relays**  
Basic Relay, Auxiliary Contact Modules

UL / CSA / IEC / CE

Contact Arrangement	UL/CSA General Use 600V AC max	UL/CSA Pilot Duty Rating	AC operated Type	Price
			Article No.	see price list
N.O. = normally open N.C. = normally closed	A		Coil voltages shown in (...) For other coil voltages, see page 02/030	
		Circuit symbol	Contact code number and version <sup>3)</sup>	
<b>Basic relays with positively driven contacts<sup>1)</sup></b>				
 4 N.O. -	10	A 600 P300	 40E - -	<b>DILER-40(120V60Hz)</b> 051756
3 N.O. 1 N.C.			 - - 31E -	<b>DILER-31(120V60Hz)</b> 051765
2 N.O. 2 N.C.			 - - 22E	<b>DILER-22(120V60Hz)</b> 051774
<b>Auxiliary contact modules with positively driven contacts<sup>1)</sup></b>				
2-pole - 2 N.C.	10	A 600 P300	 42E 33 24	<b>02DILE</b> 010240
1 N.O. 1 N.C.			 51E 42 33	<b>11DILE</b> 010224
2 N.O. -			 60E 51 42	<b>20DILE</b> 010208
1 N.O. <sup>2)</sup> 1 N.C. <sup>3)</sup>			 51 42 33	<b>11DDILE</b> 049824
4-pole - 4 N.C.	10	A 600 P300	 44E 35 26	<b>04DILE</b> 010256
1 N.O. 3 N.C.			 53E 44 35	<b>13DILE</b> 002397
2 N.O. 2 N.C.			 62E 53 44	<b>22DILE</b> 010288
3 N.O. 1 N.C.			 71E 62 53	<b>31DILE</b> 048912
4 N.O. -			 80E 71 62	<b>40DILE</b> 010304
2 N.O. <sup>2)</sup> 2 N.C. <sup>3)</sup>			 62 53 44	<b>22DDILE</b> 049823

**Notes**













<sup>1)</sup> Positively driven contacts (ZH1/457 Specification). Standard N.O. and N.C. contacts can never be closed simultaneously. By definition, overlapping contacts, i.e. EM (Early Make) and LB (Late Break) cannot be positively driven.

<sup>2)</sup> 1 early-make contact  
1 late-break contact

<sup>3)</sup> Refer to explanation in Notes column

**DILER Industrial Control Relays**  
Basic Relay, Auxiliary Contact Modules

UL / CSA / IEC / CE

Circuit symbol	Contact code number and version <sup>3)</sup>	DC operated Type	Price
		Article No.	see price list
		Coil voltages shown in (...) For other coil voltages, see page 02/030	
	40E - -	<b>DILER-40-G(24VDC)</b> 010223	
	- - 31E -	<b>DILER-31-G(24VDC)</b> 010157	
	- - 22E	<b>DILER-22-G(24VDC)</b> 010042	
	42E 33 -	<b>02DILE</b> 010240	Contact numbers to EN 50 011 Terminal markings: coils to EN 50 005 <b>DC coils:</b> Supplied standard with a resistor/diode combination surge suppressor. Coil power consumption: 2.6 W
	51E 42 -	<b>11DILE</b> 010224	
	60E 51 -	<b>20DILE</b> 010208	
	51 42 -	<b>11DDILE</b> 049824	
	44E 35 -	<b>04DILE</b> 010256	
	53E 44 -	<b>13DILE</b> 002397	
	62E 53 -	<b>22DILE</b> 010288	
	71E 62 -	<b>31DILE</b> 048912	
	80E 71 -	<b>40DILE</b> 010304	
	62 53 -	<b>22DDILE</b> 049823	
Version E combinations correspond to EN 50 011 and are to be preferred; other combinations correspond to EN 50 005.			

**Notes**

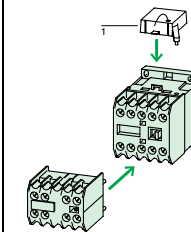

Accessories	Page
1 Suppressor	02/024
Other accessories	02/024

**Contact Code Number:**



















The contact code number provides useful information of the relay. It refers to the total number of N.O. contacts (1st digit) and N.C. contacts (2nd digit) found on the device. Adding both digits will result in the total number of contacts.

**Example:**  
**DILER-40 + 04DILE =**  
4 N.O. + 4 N.C. contacts, for a total of 8 eight contacts

Some contact combinations are preferred when used in configurations conforming to European Norms (EN Standards). These are denoted by the letter "E" in the contact code number and are in accordance with DIN EN 50 011. All other combinations without the letter "E" are in accordance with DIN EN 50 005. In the example above, the combination of **DILER-40 + 04DILE** yields a relay with Type E configuration (44E).

**DIL R Industrial Control Relays**  
Basic Relay, Modules

UL / CSA / IEC / CE

Contacts	UL/CSA General Use 600V AC max.	UL/CSA Pilot Duty Rating	AC operated Type	Price						
			Article No.	see price list						
			Coil voltages shown in (...) For other coil voltages, see page 02/030							
N.O. = normally open N.C. = normally closed	A		Circuit symbol	Contact code number and version <sup>2)</sup>						
<b>Basic relays with positively driven contacts<sup>1)</sup></b>										
	4 N.O.	-	15	A 600 P300		40E	-	-	<b>DILR40</b> (120V60Hz) 043753	
	3 N.O.	1 N.C.				-	31E	-	<b>DILR31</b> (120V60Hz) 043765	
	2 N.O.	2 N.C.				-	-	22E	<b>DILR22</b> (120V60Hz) 043777	
<b>Auxiliary contact modules with positively driven contacts<sup>1)</sup></b>										
	2-pole	-	2 N.C.	15	A 600 P300		42E	33	24	<b>02DIL</b> 098145
		1 N.O.	1 N.C.				51E	42	33	<b>11DIL</b> 010345
		2 N.O.	-				60E	51	42	<b>20DIL</b> 012718
	4-pole	-	4 N.C.	15	A 600 P300		44E	35	26	<b>04DIL</b> 015091
		1 N.O.	3 N.C.				53E	44	35	<b>13DIL</b> 017464
		2 N.O.	2 N.C.				62E	53	44	<b>22DIL</b> 019837
		3 N.O.	1 N.C.				71E	62	53	<b>31DIL</b> 010752
		4 N.O.	-				80E	71	62	<b>40DIL</b> 022210
<b>Pneumatic timer module, convertible time ranges of : 0.2 – 30 s and 20 – 180 s</b>										
	ON-delayed	1 N.O.	1 N.C.	10	A 300		51	42	33	<b>TPE11DIL</b> 002279
	OFF-delayed	1 N.O.	1 N.C.	10	A 300		51	42	33	<b>TPD11DIL</b> 002280
<b>Mechanical latching module</b>										
							40E	31E	22E	<b>VDIL</b> (120V60HZ) 043822

**Notes**  
 1) Positively driven contacts (ZH1/457 Specification): Standard N.O. and N.C. contacts can never be closed simultaneously. By definition, overlapping contacts, i.e. EM (Early Make) and LB (Late Break) cannot be positively driven.  
 2) Refer to explanation in Notes column

**DIL R Industrial Control Relays**  
Basic Relay, Modules

UL / CSA / IEC / CE

DC operated Type	Price		
Article No.	see price list		
Coil voltages shown in (...) For other coil voltages, see page 02/030			
<b>DILR40-G</b> (24VDC) 048537		Contact numbers to EN 50 011 Terminal markings: coils to EN 50 005	
<b>DILR31-G</b> (24VDC) 048532		DIL R40: supplied without front plate → Page 02/025	
<b>DILR22-G</b> (24VDC) 048526			
<b>02DIL</b> 098145		Version E combinations correspond to EN 50 011 and are to be preferred; other com- binations correspond to EN 50 005	
<b>11DIL</b> 010345			
<b>20DIL</b> 012718			
<b>04DIL</b> 015091			
<b>13DIL</b> 017464			
<b>22DIL</b> 019837			
<b>31DIL</b> 010752			
<b>40DIL</b> 022210			
<b>TPE11DIL</b> 002279		Version E combinations correspond to EN 50 011 and are to be preferred; other com- binations correspond to EN 50 005	
<b>TPD11DIL</b> 002280			
<b>V-GDIL</b> (24VDC) 048562		Maximum impulse duration for DC energization: 200ms	

**Notes**

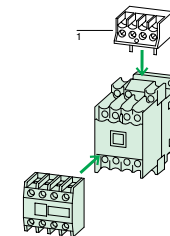

Accessories	Page
1 Interface module	02/024
Other accessories	02/024

**Contact Code Number:**

The contact code number provides useful information of the relay. It refers to the total number of N.O. contacts (1st digit) and N.C. contacts (2nd digit) found on the device. Adding both digits will result in the total number of contacts.



**Example:**  
**DILR40 + 04DIL =**  
 4 N.O. + 4 N.C. contacts, for a total of eight contacts.

Some contact combinations are preferred when used in configurations conforming to European Norms (EN Standards). These are denoted by the letter "E" in the contact code number and are in accordance with DIN EN 50 011. All other combinations without the letter "E" are in accordance with DIN EN 50 005. In the example above, the combination of **DILR40 + 04DIL** yields a relay with Type E configuration (44E).

Maximum impulse duration for DC energization: 200ms

DIL R Industrial Control Relays  
Complete Units

UL / CSA / IEC / CE

Contacts	UL/CSA General Use 600V AC max.	UL/CSA Pilot Duty Rating	AC operated Type	Price see price list
N.O. = normally open N.C. = normally closed	A		Circuit symbol	Coil voltages shown in (...) For other coil voltages, see page 02/030
<b>Complete units with 1 early-make contact, 1 late-break contact</b>				
2 N.O. 2 N.C.	15	A 600 P 300		22 <b>DILR22D(120V60Hz)</b> 043789
4 N.O. 4 N.C.				44 <b>DILR44D(120V60Hz)</b> 043800
5 N.O. 3 N.C.				53 <b>DILR53D(120V60Hz)</b> 043811

DIL R Industrial Control Relays  
Complete Units

UL / CSA / IEC / CE

DC operated Type	Price see price list
Article No.	
Coil voltages shown in (...) For other coil voltages, see page 02/030	
<b>DILR22D-G(24VDC)</b> 048542	Terminal markings: coil to EN 50 005
<b>DILR44D-G(24VDC)</b> 048547	DILR22D supplied with front plate
<b>DILR53D-G(24VDC)</b> 048552	

## Notes

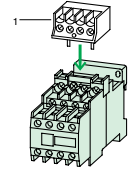

## Accessories

1 Interface module  
Other accessories

## Page

02/024  
02/024



## Contact Code Number:

The contact code number provides useful information of the relay. It refers to the total number of N.O. contacts (1st digit) and N.C. contacts (2nd digit) found on the device. Adding both digits will result in the total number of contacts.

Example:  
**DILR22D** =

2 N.O. + 2 N.C. contacts, for a total of 4 contacts

The "D" shown following the contact code number refers to the fact 1 N.O. contact is an early-make contact and 1 N.C. is a late-break contact.

	UL/CSA General Use 300V AC max.	UL/CSA Flot Duty Rating	Time range	24 – 240 V, 50/60 Hz, AC 24 – 240 V, DC Type Article No.	Price see price list
<b>A</b>					
<b>Timing relay, ON-delayed</b>					
	6	B300	1,5 – 30 s	<b>DILET11-30-A</b> 048878	
	6	B300	0,05 – 1 s 0,15 – 3 s 0,5 – 10 s 3 – 60 s 0,15 – 3 min 0,5 – 10 min 3 – 60 min 0,15 – 3 h 0,5 – 10 h 3 – 60 h	<b>DILET11-M-A</b> 048886	
<b>Multi-function relay with connection for remote potentiometer</b>					
	6	B300	0,05 – 1 s 0,15 – 3 s 0,5 – 10 s 3 – 60 s 0,15 – 3 min 0,5 – 10 min 3 – 60 min 0,15 – 3 h 0,5 – 10 h 3 – 60 h	<b>DILET70-A</b> 048893	

**Timing chart**  
Approximate values, not applicable for remote potentiometer

**Setting example (2 ways)**

Using the chart:

Time range of timing relay      60 min  
Time required                        42 min  
Setting required on time selection dial      7

Calculating the setting:

$$\frac{\text{time required} \times 10}{\text{timing range of timing relay}} = \text{Setting on time selection dial}$$

$$\frac{42 \text{ min} \times 10}{60 \text{ min}} = 7$$

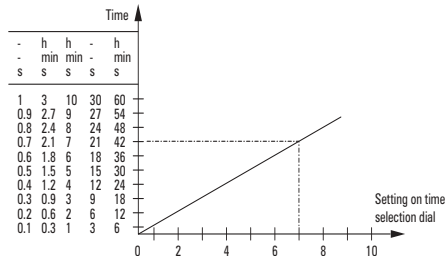

Available functions<sup>1)</sup>

Terminal markings



Dry contact  
Do not apply voltage!

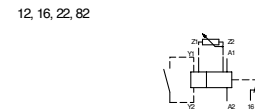
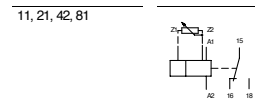
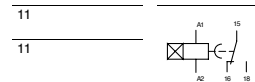

Notes

<sup>1)</sup> DILET 11 supplied with this function as standard

**Notes**

**One Device for All Voltage Ratings!**  
The DILET timing relays operate reliably when actuated by DC and AC voltage levels in the range indicated in the table below. There is no need to specify 'coil' voltages or stock coils

Type suffix	Actuating voltage printed on unit	
	V DC	V AC
-A	24 – 240	24 – 240, 50/60 Hz
-A	Voltage tolerance:	
	V DC	V AC
-A	16.8 – 288	20.4 – 264

Allowable cable length:

	Connection to Y1/Y2 Z1/Z2
Unshielded conductors AWG 14 ... 18	250 m
Conductors in same conduit or cable duct as 50/60 Hz power conductors	50 m

Accessories:	Page
Tamper-proof cover	02/025
Remote potentiometer	02/026

**Flow diagrams**

LED display

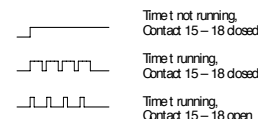

**11 ON-delayed**

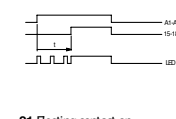

**12 OFF-delayed**

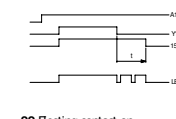

**16 ON and OFF-delayed**

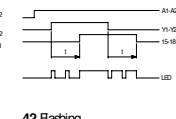

**21 Fleeting contact on energization**

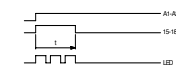

**22 Fleeting contact on de-energization**



**42 Flashing**

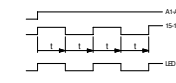

**81 Pulse generating**

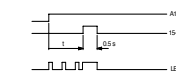

**82 Pulse shaping**

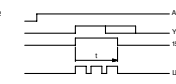

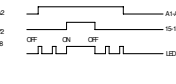

**ON-OFF function**



**ETR 4 Electronic Timing Relays**

UL/ CSA / IEC / CE

			24 – 240 V, 50/60 Hz, AC		
			24 – 240 V, DC	Type	Price
			UL/CSA General Use 250V AC max	UL/CSA Flot Duty Rating	Article No.
			Time range	see price list	
<b>A</b>					
<b>Timing relay, ON-delayed</b>					
	5	B300	0,05 – 1 s 0,15 – 3 s 0,5 – 10 s 1,5 – 30 s 5 – 100 s 15 – 300 s 1,5 – 30 min 15 – 300 min 1,5 – 30 h 5 – 100 h	<b>ETR4-11-A</b> 031882	
<b>Star-delta timing relay</b>					
	5	B300	3 – 60 s	<b>ETR4-51-A</b> 031884	
<b>Multi-function relay</b>					
	5	B300	0,05 – 1 s 0,15 – 3 s 0,5 – 10 s 1,5 – 30 s 5 – 100 s 15 – 300 s 1,5 – 30 min 15 – 300 min 1,5 – 30 h 5 – 100 h	<b>ETR4-69-A</b> 031891	

**The Entire Family of ETR 4 Timing Relays Feature Many Advantages:**

- Micro-processor controlled for high repeat accuracy
- Very high noise immunity, designed for industrial application
- LED's to signal state of output contacts and running status
- Easy setting of timing ranges and functions
- Simple to install and wire
- One device covers all AC and DC voltages across a broad range: Simplifies and minimizes inventories

**ETR4 Electronic Timing Relays**

UL/ CSA / IEC / CE

Available function <sup>1)</sup>	Terminal markings	Available function <sup>1)</sup>	Terminal markings
----------------------------------	-------------------	----------------------------------	-------------------

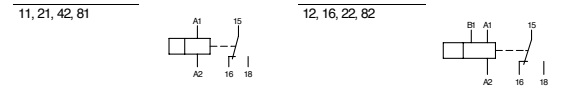
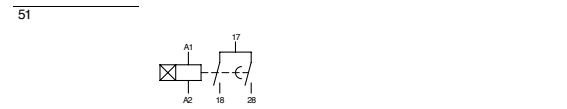

**Notes** <sup>1)</sup> ETR4-11 and ETR4-51 supplied with stated function as standard

**Notes**  
**One Device for All Voltage Ratings!**  
The ETR4 timing relays operate reliably when actuated by DC and AC voltage levels in the range indicated in the table below. There is no need to specify coil voltages or stock coils.

Type suffix	Actuating voltage printed on unit	
	V DC	V AC
-A	24 – 240	24 – 240, 50/60 Hz
Voltage tolerance		
-A	16,8 – 288	20,4 – 264

Allowable wire length:

	Connection to B1
Unshielded conductors AWG 14 ... 18	250 m
Conductors in same conduit or cable duct as 50/60 Hz power conductors	50 m

Accessories	Page
Mounting dip	02/026

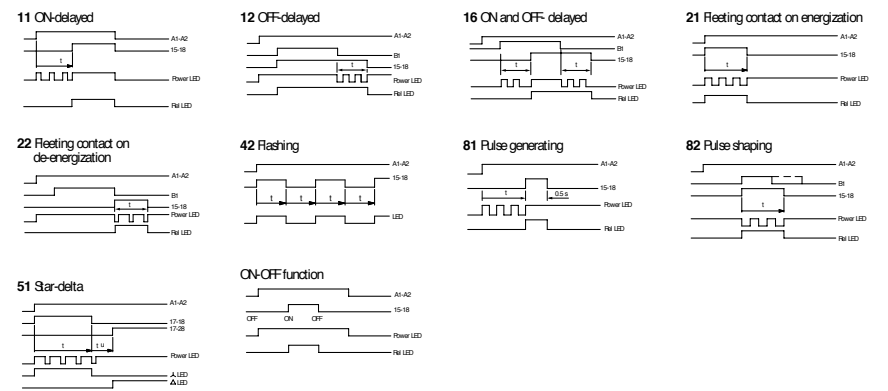

## ETR 4 Electronic Timing Relays

UL / CSA / IEC / CE

UL/CSA General Use 250V AC max.	UL/CSA Flot Duty Rating	Time range	24 – 240 V, 50/60 Hz, AC 24 – 240 V, DC	Type Article No.	Price see price list
A					
<b>Multi-function relay</b> With two changeover contacts and connection for remote potentiometer. Can be converted to two timed contacts or one non-delayed contact and one timed contact.					
5	B 300	0,05 – 1 s 0,15 – 3 s 0,5 – 10 s 1,5 – 30 s 5 – 100 s 15 – 300 s 1,5 – 30 min 15 – 300 min 1,5 – 30 h 5 – 100 h	<b>ETR4-70-A</b> 031888		

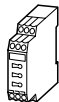

## Notes

**One Device for All Voltage Ratings!**  
The ETR 4 timing relays operate reliably when actuated by DC and AC voltage levels in the range indicated in the table below. There is no need to specify 'coil' voltages or stock coils.

Type suffix	Actuating voltage printed on unit	
	V DC	V AC
-A	24 – 240	24 – 240, 50/60 Hz
Voltage tolerance		
	V DC	V AC
	16.8 – 288	20.4 – 264

Allowable wire lengths:

	Connection to B1 Z1/Z2
Unshielded conductors AWG 14 ... 18	250 m
Conductors in same conduit or cable duct as 50/60Hz power conductors	50 m

Accessories	Page
Mounting clip	02/026
Remote potentiometer	02/026

ETR 4 Electronic Timing Relays

UL / CSA / IEC / CE

**A2/X1 linked**

→ 2 timed contacts

Available functions

11, 21, 42, 81  
ON – OFF

Connection diagrams

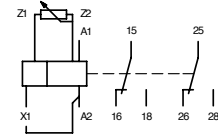

Available functions

12, 16, 22, 82  
ON – OFF

Connection diagrams

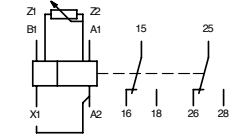

**11 ON-delayed**

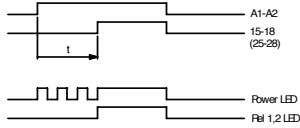

**21 Fleeting contact on energization**

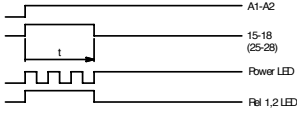

**12 OFF-delayed**

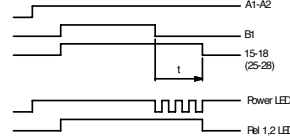

**16 ON and OFF-delayed**

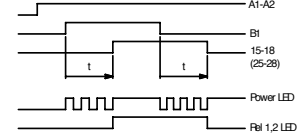

**42 Flashing**

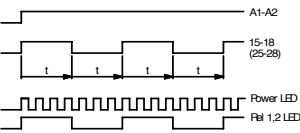

**81 Pulse generating**

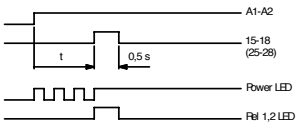

**22 Fleeting contact on de-energization**

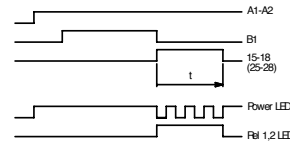

**82 Pulse shaping**

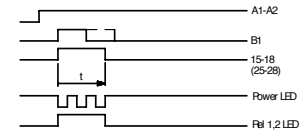

**ON-OFF function**

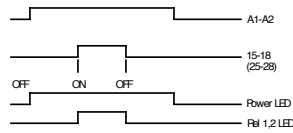

**A2/X1 not linked**

→ 1 non-delayed and 1 timed contact

Available functions

11, 21, 42, 81  
ON – OFF

Connection diagrams

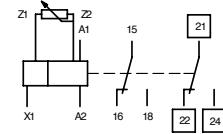

Available functions

12, 16, 22, 82  
ON – OFF

Connection diagrams

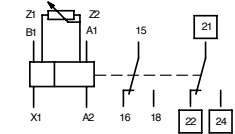

**11 ON-delayed**

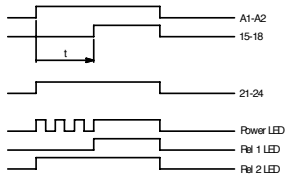

**21 Fleeting contact on energization**

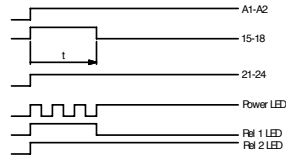

**12 OFF-delayed**

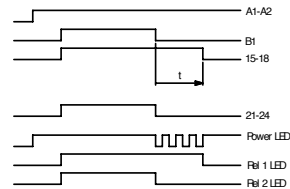

**16 ON and OFF-delayed**

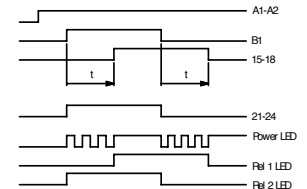

**42 Flashing**

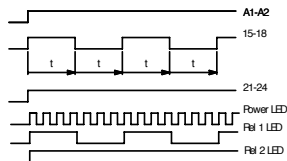

**81 Pulse generating**

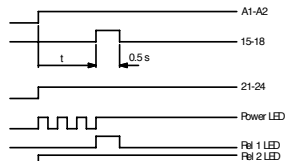

**22 Fleeting contact on de-energization**

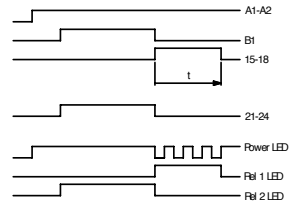

**82 Pulse shaping**

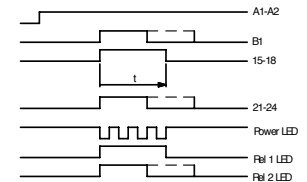

**ON-OFF function**

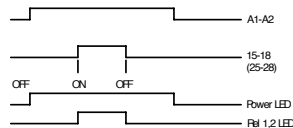

## ESR Electronic Safety Relays

### Description

#### Fields of application

Electronic safety relays are used for monitoring safety control circuits. The requirements for electrical equipment of machines are defined in accordance with IEC/EN 60 204. The machine user must assess the risk at his machine in accordance with EN 954-1, and fit a control system which meets the requirements for the relevant safety category 1, 2, 3, or 4.

#### Construction

The electronic safety relay consists of a power section, the electronics and two redundant relays with interlocked opposing contacts for the enabling and signalling paths.

#### Product range overview

The range includes relays for:



Emergency-Stop circuits



Monitoring of safety mats and safety bumpers

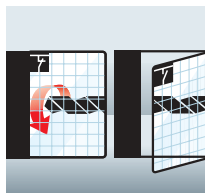

Monitoring of protective guards

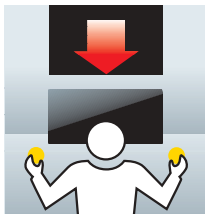

Monitoring of two-hand controls

Contact expansion modules with and without time delay are also available.

#### Safety category

ESR electronic safety relays are approved by the German Trade Associations and comply with safety category 3 or 4. The safety category of a control system results from its combination with the external wiring, for which the machine user is responsible. The electronic safety relays are tolerant of one fault, in other words, a single fault in the safety circuit does not result in a dangerous state. Two mutually independent, simultaneously occurring faults are excluded in EN 954-1.

#### Stop category

IEC/EN 60 204-1 stipulates two relevant stop categories for stopping in the event of an emergency:

- STOP category 0: Stopping by means of immediate disconnection of power from the machine drive elements.
- STOP category 1: Controlled stopping, where the power to the machine drive elements is retained, in order to achieve cessation of machine movement. The power is only interrupted, when the machine has come to a standstill.

The safety relays for Emergency-Stop applications and non-delayed expansion modules are suitable for Stop category 0. Delayed contact expansion modules meet the requirements of Stop category 1.

#### Function

In fault-free operation, following the starting command, the safety circuits are monitored by the electronics, and with the assistance of the relays, enable the enabling paths. Following the switch Off command, and also in the event of a fault (earth fault, faulty insulation, wire breakage, etc.), the enabling paths are blocked immediately (STOP category 0) or with a time delay (STOP category 1), and the motor is disconnected from the mains supply. In redundant safety circuits, a short-circuit does not result in danger, so only when the circuit is re-energized is the fault detected and starting prevented.









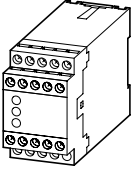

#### Single/dual channel design

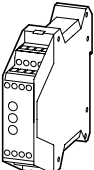
Safety relays for stopping in the event of an emergency and for monitoring of protective guards are available for single- and dual channel applications. The single channel construction enables earth-fault monitoring of the safety circuit. For the dual channel application, the Emergency-Stop circuit or the protective guard circuit is constructed as a redundant circuit. In this way monitoring for short-circuits and wire insulation faults is also implemented.

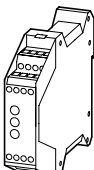
Furthermore, the device can be used with or without reset monitoring. The device is started only as a result of the falling edge of the On button, and the enabling paths switched through. An application for the device without restart monitoring is for example, for monitoring protective doors for an automatic restart.

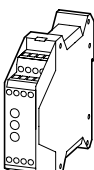
## ESR Electronic Safety Relays

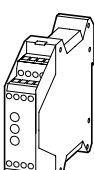
### Basic Units, Contact Expansion Module









Actuating voltage $U_c$	Relay safety category to EN 954-1	Enabling path to IEC/EN 60 204			Type	Price
		0	1			
					Article No.	see price list
<b>Safety relay for Emergency-Stop and protective-door monitoring<sup>1)</sup></b>						
 230 V 50/60 Hz	Dual-channel		4	3	-	<b>ESR3-NO-31(230V)</b> 214615
 24 V DC 50/60 Hz	Single-channel		3	3	-	<b>ESR4-NO-31</b> 214612
24 V DC 50/60 Hz	Dual-channel		4	2	-	<b>ESR4-NO-21</b> 214613
24 V DC	Dual-channel Off-delayed 0.15 - 3 s		3 <sup>4)</sup> / 4 <sup>5)</sup>	2	1	<b>ESR4-NV3-30</b> 214616
24 V DC	Dual-channel Off-delayed 1.5 - 30 s		3 <sup>4)</sup> / 4 <sup>5)</sup>	2	1	<b>ESR4-NV30-30</b> 214617
24 V DC	Dual-channel delayed 1.5 - 30 s		3 <sup>4)</sup> / 4 <sup>5)</sup>	2	1	<b>ESR4-NT30-30</b> 225011
<b>Safety relay for safety mat monitoring<sup>1)</sup></b>						
 24 V DC	Dual-channel		4	2	-	<b>ESR4-NM-21</b> 214619
<b>Two-hand control relay<sup>1)</sup></b>						
 24 V DC 50/60 Hz, suitable for applications to EN 574 Typ III C	Dual-channel		4	2	-	<b>ESR4-NZ-21</b> 214620
<b>Contact expansion modules<sup>1)</sup></b>						
 24 V DC 50/60 Hz	non-delayed		4 <sup>2)</sup>	4 <sup>3)</sup>	-	<b>ESR4-NE-42</b> 214614
24 V DC	delayed $t_A = 3$ s		4 <sup>2)</sup>	-	4	<b>ESR4-VE3-42</b> 214618

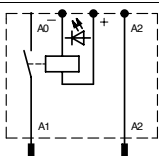

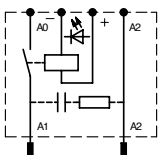
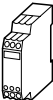
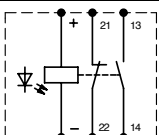
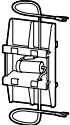
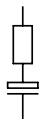



#### Notes

- 1) Additional information and switching examples → Safety Application Guide TED-009GB
- 2) The basic unit determines the maximum safety category
- 3) The basic unit determines the maximum stop category
- 4) Delayed contacts
- 5) Non-delayed contacts

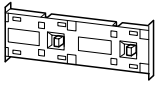

**Accessories**

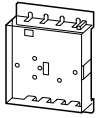
**Interface Modules, Suppressors**

	Output Pilot duty rating		Actuating voltage actuating current	For use with relays	Type	Price	
	AC A	DC A					Artide No.
<b>Interface modules, plug-in type</b>							
	B 300	R 300	24/11		DIL R.	<b>VS1 DIL</b> 055480	For energizing of relay low level 24 V DC inputs. The VS1 and VS2 plug directly into the DIL R coil terminals, whereas the ETS4-VS3 mounts separately on a DIN rail and is suitable for all relays. In cases where the rated coil current of a device exceeds 2A, use a DILER-G as an interface relay.
With integral suppressor circuit 	B 300	R 300	24/11		DIL R.	<b>VS2 DIL</b> 057853	
<b>Amplifier module for separate mounting</b>							
	B 300		24/25		As required	<b>ETS4-VS3</b> 083094	
<b>Drop-out delay mechanism</b>							
			24/-		DIL E..	<b>TDDILE24</b> 090200	Lengthens the drop-out time of an electro magnet. For use with DILER(M) with DC operated coil only. Drop-out delay with auxiliary contacts: 100ms, without: 130 ms
<b>Suppressors</b>							
Varistor suppressors 			24 – 48 V		DIL E..	<b>VGDILE48</b> 010320	For AC operated 50-60 Hz relays only. DC operated devices have built-in surge suppressors.
			110 – 250 V			<b>VGDILE250</b> 010336	
			380 – 415 V			<b>VGDILE415</b> 010463	
			12 – 24 V	DIL R..	<b>VGBDIL24</b> 076837	For AC operated 50-60 Hz and DC operated relays.	
			24 – 48 V		<b>VGBDIL48</b> 071609		
			110 – 250 V		<b>VGBDIL250</b> 071610		
			380 – 415 V		<b>VGBDIL415</b> 071611		
RC suppressors			24 – 48 V		DIL E..	<b>RCDILE48</b> 044264	For AC operated 50-60 Hz relays
			110 – 250 V			<b>RCDILE250</b> 046320	
			24 – 48 V	DIL R..	<b>RCBDIL48</b> 067345		
			110 – 250 V		<b>RCBDIL250</b> 069718		
			380 – 415 V		<b>RCBDIL415</b> 072091		
Free-wheel diode suppressor			12 – 250 V		DIL R..	<b>FBDIL</b> 074464	For DC operated relays Longer drop-out delay of coil should be taken into consideration

		For use with	Type	Price	
			Article No.	see price list	
<b>Spacers</b>					
	Provides a mechanical link between groups of components to better secure them when mounted and wired together in an assembly.	DILE.. DILET...	<b>VODILE</b> 026634		No spacing between devices
		DIL R.. ETR4	<b>VODIL</b> 010772		No spacing between devices
		DIL R.. ETR4	<b>V5/15DIL</b> 013145		5 mm device spacing 15 mm device spacing when using mechanical interlock
<b>Mechanical Interlock</b>					
		DILE..	<b>MVDILE</b> 010113		To mechanically interlock two AC or DC operated devices mounted either horizontally or vertically. No spacing between devices. Mechanical lifespan 2.5 million operations Additional auxiliary contact mounting is possible
<b>Paralleling bridge</b>					
	for parallel connection of auxiliary contacts	DILE.. ...DILE DIL R ...DIL	<b>BT480</b> <sup>1)</sup> 052785		Not insulated Standard quantity: 100 <sup>1)</sup> must be ordered in standard quantities
<b>Connection tabs for fast-on connectors DIN 46 244</b>					
	For auxiliary contacts and coil connections	DILE.. DILET.. DIL R..	<b>BT483</b> <sup>1)</sup> 059904		Use connectors with insulated sleeves Standard quantity: 100 <sup>1)</sup> must be ordered in standard quantities
<b>Tamper-proof cover</b>					
	Transparent	DILE.. DILET...	<b>HDILE</b> 010482		Cover snap-fits onto the device and can be sealed to prevent tampering. IP40 environmental rating. Cover may also be drilled to provide access to the DILET timer adjustment dial.
		TPE(H) TPD(H)	<b>PL-DILT</b> 036073		Cover is fastened via a screw. Sealable to prevent access.
<b>Front plate</b>					
		DIL R	<b>HDILOOM</b> 093665		Front plate serves as cover for the basic relays and also provides a location for the component identification marking system.

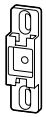
## Accessories

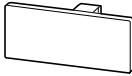
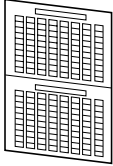
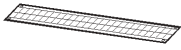
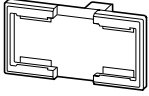
		For use with	Type	Price	
			Article No.	see price list	
<b>Remote potentiometer IP 54</b>					
	10 k $\Omega$ linear 0.25 W max.	DIL ET... ETR4-70	<b>FR-10</b> 031344		
<b>Mounting clip</b>					
		ETR4	<b>CS-TE</b> 095853		For panel mounting of ETR4 timing relays
<b>Component labelling system</b>					
<b>Clip-in label plate</b>					
	8 x 10 mm	...DIL	<b>KG10</b> <sup>1)</sup> 022256		Clips into 2-pole auxiliary contact modules  Standard quantity: 500
	8 x 20 mm	...DILE, DILER...DIL, DIL R	<b>KG20</b> <sup>1)</sup> 091075		Clips into 4-pole auxiliary contact modules and basic units  Standard quantity: 500
	8 x 17,5 mm Color: white	DIL..	<b>XGKS-Z</b> <sup>1)</sup> 207508		For use with Moeller equipment with corresponding mounting hole  Standard quantity: 500
	7,5 x 17 mm  Color: yellow HKS3 ( $\approx$ FAL 1018)	XGKS-T, KG 20  For inscription using laser printer, inkjet printer, plot- ter, marker pen, photocopier	<b>XGKE-GE</b> <sup>2)</sup> 207517		Standard quantity: pad of 25 sheets 240 labels persheet, self-adhesive  Price per sheet
	8 x 17,5 mm  Color: white	XGKA-Z  Can be inscribed by marker pen or plotter by Phoenix Contact or others.	<b>XGKS-T</b> <sup>2)</sup> 207505		Standard quantity: 10 cards 40 labels per card
	Color: FAL 7035, light grey	DIL..	<b>XGKA-Z</b> <sup>1)</sup> 207513		To secure XGKS on Moeller equipment with the corresponding mounting hole  Standard quantity: 250

## Notes

- <sup>1)</sup> Must be ordered in standard quantity  
<sup>2)</sup> Consult Moeller Electric for inscription software

**Industrial Control Relays**  
Accessories, Contact Travel Diagrams

UL / CSA / IEC / CE

Industrial Control Relays  
Electronic Timing Relays

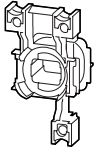
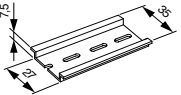
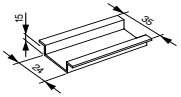
	For use with	Type Article No.	List Price see price list
<b>Individual coils</b> 	AC voltage	DIL R	<b>J-DIL00M(...)</b>
	DC voltage	DIL R	<b>G-DIL00M(...)</b>
See page 02/030 for available ratings Specify coil voltage when ordering			
<b>Mounting rails</b>  	Length: 2 m (6 1/2 ft.)  DILE.. DILR.. ETR4	<b>TS 35 x 7.5</b> 053030	For fast and easy installation of devices on DIN standard mounting rail to EN 50 022
		<b>TS 35 x 15</b> 050657	

The diagrams show the closing and opening travel of the relays and auxiliary contacts at no-load.  
Tolerances are not taken into consideration.

**DIL ER-AC**

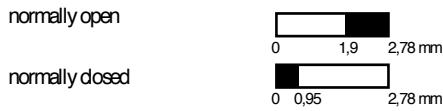

**DIL R**

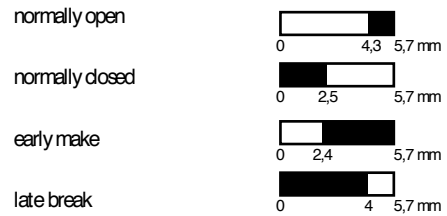

**DIL ER-DC**

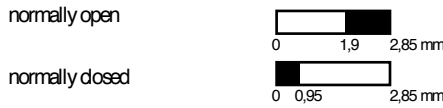

**...DIL**



**...DILE**

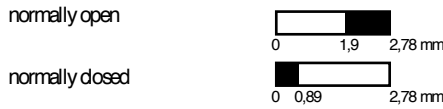

**TP... 11 DIL**



**...D DILE**

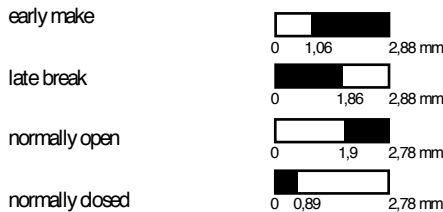

## DIL Industrial Control Relays, DIL ET Electronic Timing Relays Characteristics

### DILR (AC-15)

Component lifespan (operations)  $I_e$  = Rated operational current  
 ① = normally open  
 ② = normally closed

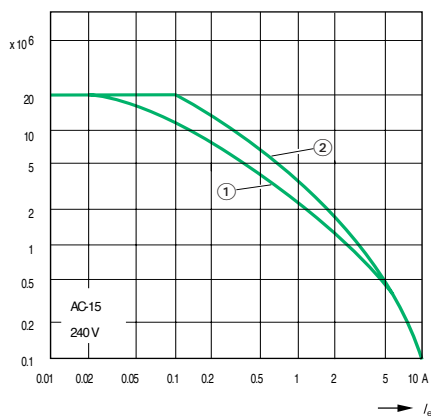

### DILR (AC-15)

Max. switching frequency (approx.)  
 $I_e$  = Rated operational current

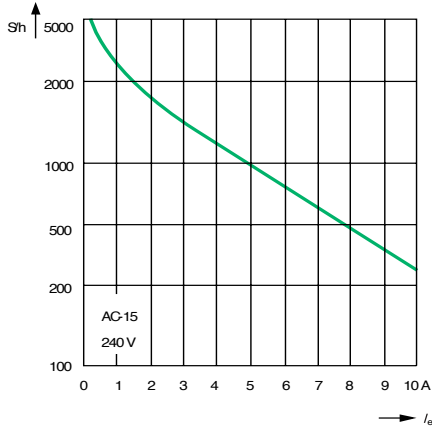

### DILR (DC-13<sup>1)</sup>)

Component lifespan (operations)  
 $I_e$  = Rated operational current

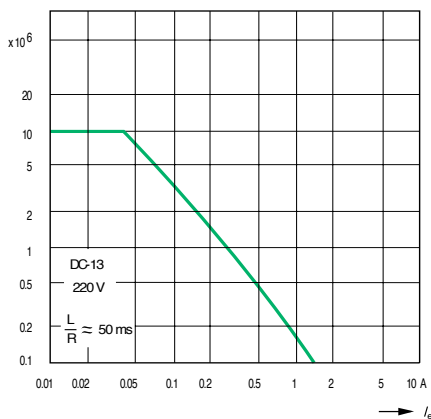

### DILR (DC-13<sup>1)</sup>)

Max. switching frequency (approx.)  
 $I_e$  = Rated operational current

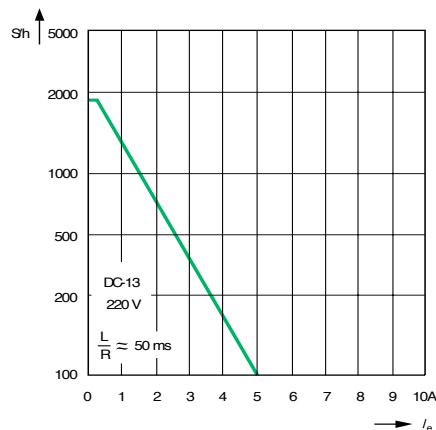

### DILR (DC-13<sup>1)</sup>)

Component lifespan (operations)  
 $I_e$  = Rated operational current

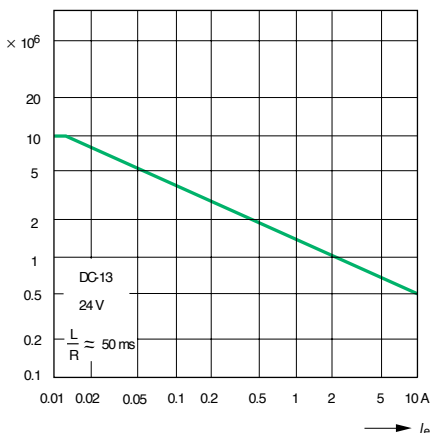

### DILR (DC-13<sup>1)</sup>)

Max. switching frequency (approx.)  
 $I_e$  = Rated operational current

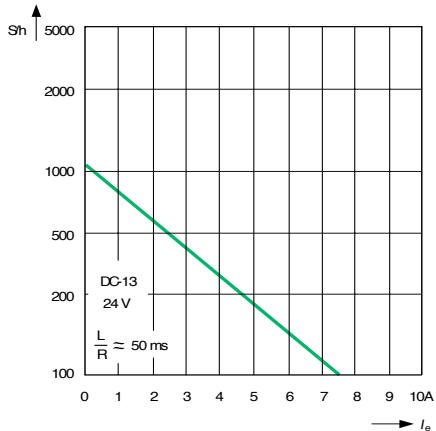

**Notes**

<sup>1)</sup> Make and break conditions to DC-13, time constant as stated.

# DIL Industrial Control Relays, DILET Electronic Timing Relays Characteristics

## DIL ER (AC-15)

Component lifespan (operations)  
 $I_e$  = Rated operational current

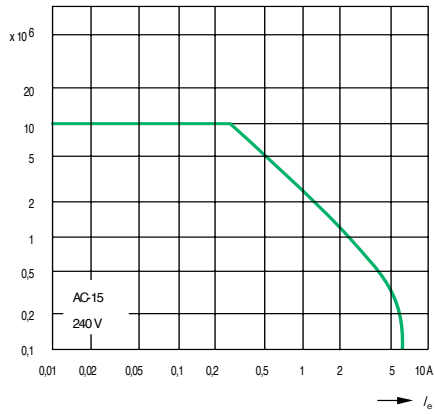

## DILET (AC-11)

Component lifespan (operations)  
 $I_e$  = Rated operational current

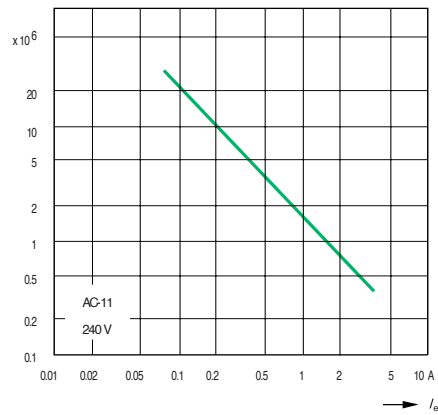

# DIL ER, DIL R Industrial Control Relays

## Technical Data

				DIL ER ... DIL E	DIL R ... DIL
<b>General</b>					
Standards				UL, CSA, IEC/EN 60 947, VDE 0660	
Mechanical lifespan					
AC operated	Operations	x10 <sup>6</sup>	10	20	
DC operated	Operations	x10 <sup>6</sup>	20	20	
Max. switching frequency, mechanical				9000	7000
Climatic proofing				Damp heat, constant to IEC 60 068-2-3 Damp heat, cyclical to IEC 60 068-2-30	
Ambient temperature					
open	min./max.	°C	-25/+50	-25/+50	
enclosed	min./max.	°C	-25/+40	-25/+40	
Mounting position				as required, except vertical with A1/A2 at bottom	as required, except suspended
Mechanical shock resistance					
Sinusoidal impulse 10 ms					
Basic unit	N.O./N.C. contact	g	10/8	–	
Basic unit with auxiliary contact module	N.O./N.C. contact	g	10/8	–	
Sinusoidal impulse 20 ms					
Basic unit	N.O./N.C. contact	g	–	10/6	
Basic unit with auxiliary contact module	N.O./N.C. contact	g	–	10/6	
Degree of protection				IP20	IP20 (DIL R) IP00 (... DIL)
Finger-safe, back of hand save to VDE 0106, part 100				yes	
Dimensions				→ page 02/055	→ page 02/056
Weight					
AC operated		kg	0.17	→ page 14/020	
DC operated		kg	0.2	→ page 14/020	
Terminal capacity					
solid		mm <sup>2</sup>	1 x (0.75 – 2.5)	1 x (0.75 – 4)	
		mm <sup>2</sup>	2 x (0.75 – 2.5)	2 x (0.75 – 4)	
flexible with ferrule to DIN 46 228		mm <sup>2</sup>	1 x (0.75 – 1.5)	1 x (0.75 – 2.5)	
		mm <sup>2</sup>	2 x (0.75 – 1.5)	2 x (0.75 – 2.5)	
solid or stranded		min.	AWG 18	18	
		max.	AWG 14	12	
Terminal screw				M3.5	M3.5
Pozidriv screwdriver		size	2	2	
Standard screwdriver		mm	0.8 x 5.5	0.8 x 5.5	
		mm	1 x 6	1 x 6	
Tightening torque		max.	1.2	1.2	

# DIL ER, DIL R Industrial Control Relay

## Technical Data

				DIL ER ... DILE	DIL R ... DIL
<b>Contacts, IEC Data (EN 60 947)</b>					
Positively driven contacts to ZH1/457, including auxiliary contact module				yes	yes
Rated impulse withstand voltage $U_{imp}$		V		6000	8000
Overvoltage category / pollution degree				III/3	III/3
Rated insulation voltage $U_i$		V AC		690	690
Rated operational voltage $U_e$		V AC		600	500
Safe isolation to IEC 536 between coil and auxiliary contacts, and between the auxiliary contacts		V AC		300	440
Rated operational current $I_e$					
AC-15		220/240 V	A	6 (4) <sup>1)</sup>	6
		380/415 V	A	3 (2) <sup>1)</sup>	4
		500 V	A	1,5	1,5
DC-13 <sup>2)</sup>					
Above 110V and at L/R > 15ms: it is essential that an arc-quenching device (FC suppressor) be used in parallel with the contacts. C: 1µF, R 0.5 Ω in series					
L/R ≤ 15 ms: e.g. contactor coils, solenoid valves, DC motors					
Contacts in series					
1	24 V	A	2,5	10	
2 (1)	60 V	A	2,5	10 (6)	
3 (1)	110 V	A	1,5	6 (3)	
3 (1)	220 V	A	0,5	5 (1)	
L/R ≤ 50 ms: e.g. magnetic ditches, solenoid brakes					
Contacts in series					
2	24 V	A	–	6	
2	60 V	A	–	6	
3 (1)	110 V	A	–	3 (1,5)	
3 (1)	220 V	A	–	2 (1)	
Control circuit reliability $U_e = 24 V$					
$U_{min} = 17 V, I_{min} = 5.4 mA$		Fault probability	H†	< 10 <sup>28</sup> , < 1 fault in 100 million operations	
Conv. thermal current $I_{th}$			A	10	16
Component lifespan $U_e = 240 V$					
AC-15				→ page 02/029	→ page 02/028
DC-13					
L/R = 50 ms: >2 contacts operations in series at $I_e = 0.5 A$		x 10 <sup>6</sup>		0,15	→ page 02/028
Short-circuit rating when taken directly from mains or transformer > 1000 VA; without welding					
Max. overcurrent protective device		220/240 V	FKZM 0	4	4
		380/415 V	FKZM 0	4	2,4
		220/230 V	FAZ-C	–	4
Maximum fuse		500 V	A gL/gG	6	16
		500 V	A fast	10	–
Current heat loss at $I_{th}$					
per contact		AC operated	W	0.2	0.8
		DC operated	W	0.3	0.8
<b>Contacts, UL/CSA data</b>					
Pilot duty				A 600, P 300	A 600, P 300
General Use rating		600 V AC / 250 V DC		10 / 0.5	15 / 1.0

**Notes**
<sup>1)</sup> Auxiliary contact module

<sup>2)</sup> Make and break conditions to DC-13, time constant as stated

# DIL ER, DIL R Industrial Control Relays

## Technical Data

			DIL ER ... DILE	DIL R ... DIL
<b>Magnet systems</b>				
Voltage tolerance				
AC operated				
Single-voltage coil 50 Hz and dual-voltage coil 50 Hz, 60 Hz				
	Pick-up	$x U_c$	0,8 - 1,1	0,8 - 1,1
Dual-frequency coil ... V, 50/60 Hz				
	Pick-up	$x U_c$	0,85 - 1,1	0,85 - 1,1
DC operated <sup>1)</sup>				
without auxiliary contact module				
	Pick-up	$x U_c$	0,85 - 1,3	0,85 - 1,1
	Pick-up	$x U_c$	0,7 - 1,3	–
Power consumption				
AC operated				
Single-voltage coil 50 Hz and dual-voltage coil 50 Hz, 60 Hz				
	Full-in	V <sub>AW</sub>	25/22	67/52
	Sealing	V <sub>AW</sub>	4,6/1,3	8,5/2,5
Dual-frequency coil				
... V, 50/60 Hz at 50 Hz				
	Full-in	V <sub>AW</sub>	30/26	–
	Sealing	V <sub>AW</sub>	5,4/1,6	–
... V, 50/60 Hz at 60 Hz				
	Full-in	V <sub>AW</sub>	29/24	–
	Sealing	V <sub>AW</sub>	3,9/1,1	–
DC operated				
	Full-in = sealing	W	2,6	9,5
Duty factor				
		% DF	100	100
Switching times at 100% U (approximate values)				
AC operated				
closing delay			ms	14 – 21
N.O. contact			ms	8 – 18
opening delay			ms	14
with auxiliary contact module			ms	–
max. closing delay			ms	45
DC operated				
closing delay			ms	26 – 35
N.O. contact			ms	38
opening delay			ms	15 – 25
with auxiliary contact module			ms	9
max. closing delay			ms	70
max. closing delay			ms	–

Notes

<sup>1)</sup> Smoothed DC or three-phase bridge rectifier required

# TP Timer Modules, V Latching Modules, VS Interface Modules

## Technical Data

				TPE 11 DIL TPD 11 DIL	V DIL	VS 1 DIL VS 2 DIL	ETS 4-VS 3	
<b>General</b>								
Standards				UL, CSA, IEC/EN 60 947, VDE 0660				
Mechanical lifespan								
AC operated	operations	x 10 <sup>6</sup>	1	5	–	–		
DC operated	operations	x 10 <sup>6</sup>	1	1	10	30		
Max. operating frequency, mechanical								
AC operated		Ops/h	3600	1500	–	–		
DC operated		Ops/h	3600	1500	9000	72000		
Climatic proofing				Damp heat, constant, to IEC 60 068-2-3 Damp heat, cyclical, to IEC 60 068-2-30				
Ambient temperature								
open	min./max.	°C	–25/+50	–25/+50	–25/+50	–25/+60		
enclosed	min./max.	°C	–25/+40	–25/+40	–25/+40	–25/+45		
Mounting position				as required, except suspended <sup>1)</sup>	as required	as required	as required	
Mechanical shock resistance (sinusoidal shock 20ms)								
	N.O./N.C. contact	g	10/6	–	10/–	10/–		
	mechanical latching	g	–	20	–	–		
Degree of protection				IP00	IP00	IP00	IP20	
Finger safe, back of hand safe to VDE 0106, part 100				yes				
Dimensions				→ page 02/056	→ page 02/056	→ page 02/056	→ page 02/056	
Weight				kg	0.08	0.1	0.04 (VS1) 0.05 (VS2)	0.09
Terminal capacity								
solid		mm <sup>2</sup>	1 x (0.5 – 2.5)	1 x (0.5 – 2.5)	1 x (0.75 – 4)	1 x (0.75 – 2.5)		
		mm <sup>2</sup>	2 x (0.5 – 2.5)	2 x (0.5 – 2.5)	2 x (0.75 – 4)	2 x (0.75 – 1.5) <sup>2)</sup>		
flexible with ferrule to DIN 46 228		mm <sup>2</sup>	1 x (0.5 – 1.5)	1 x (0.5 – 1.5)	1 x (0.75 – 2.5)	1 x (0.75 – 2.5)		
		mm <sup>2</sup>	2 x (0.5 – 0.75)	2 x (0.5 – 0.75)	2 x (0.75 – 2.5)	2 x (0.75 – 1.5) <sup>2)</sup>		
solid or stranded		min.	AWG	18	18	18		
		max.	AWG	14	12	14		
Terminal screw				M3	M3	M3,5	M3,5	
Pozi driv screwdriver		size	2	2	2	2		
Standard screwdriver		mm	0.8 x 5.5	0.8 x 5.5	0.8 x 5.5	0.8 x 5.5		
		mm	1 x 6	1 x 6	1 x 6	1 x 6		
Tightening torque		max.	Nm	1.2	1.2	1.2		

**Notes**

- <sup>1)</sup> DIL R... -G+ TPD11 DIL, do not mount vertically  
<sup>2)</sup> Use equal cross-sections

# TP Timer Modules, V Latching Modules, VS Interface Modules

## Technical Data

				TPE 11 DIL TPD 11 DIL	V DIL	VS 1 DIL VS 2 DIL	ETS4-VS3
<b>Contacts, IEC Data (EN 60 947)</b>							
Positively driven contacts to ZH 1/457, including auxiliary contact module				yes	–	–	–
Rated impulse withstand voltage $U_{imp}$		V		6000	8000	4000	6000
Overvoltage category / pollution degree				III/3	III/3	III/2	III/3
Rated insulation voltage $U_i$		V AC		690	690	440	440
Rated operational voltage $U_o$		V AC		500	415	415	440
Rated operational current $I_o$							
AC-15		220/240 V	A	4	–	1,5	2
		380/415 V	A	4	–	1	2
DC-13 <sup>1)</sup>							
Above 110V and at L/R > 15 ms: it is essential that an arc-quenching device (FC suppressor) be used in parallel with the contacts. C: 1 $\mu$ F, R: 0,5 $\Omega$ in series							
L/R $\leq$ 15 ms: e.g. contactor coils, solenoid valves, DC motors							
Contacts in series							
1	24 V		A	10	–	1	2,6
1	60 V		A	6	–	1	1,0
1	110 V		A	3	–	1	0,6
1	220 V		A	1	–	1	0,2
L/R $\leq$ 50 ms: e.g. magnetic ditches, solenoid brakes							
Contact in series							
1	24 V		A	4	–	0,5	2,0
1	60 V		A	4	–	0,5	0,6
1	110 V		A	1	–	0,5	0,08
1	220 V		A	0,5	–	0,5	0,08
L/R $\leq$ 300 ms							
1	24 V		A	–	–	0,2	0,6
1	60 V		A	–	–	0,2	0,2
1	110 V		A	–	–	0,2	0,08
1	220 V		A	–	–	0,2	0,03
Control circuit reliability $U_o = 24$ V, $U_{mn} = 17$ V, $I_{mn} = 5,4$ mA				Fault probability	H $\ddagger$	< 10 <sup>-8</sup> , < 1 fault in 100 million operations	
Conv. thermal current $I_{th}$			A	10	–	8	6
Component lifespan at $I_o = 0.1$ A/1.2 A							
AC-15	230 V	operations	x 10 <sup>6</sup>	–	–	8/–	7/1
DC-13	230 V	operations	x 10 <sup>6</sup>	–	–	0,85/–	–
Short-circuit rating when taken directly from mains or transformer > 1000VA; without welding							
Max. overcurrent protective device		220/240 V	FKZM 0	2,5	–	–	–
		380/415 V	FKZM 0	1,6	–	–	–
Maximum fuse		500 V	A gl/gG	6	–	–	–
			A fast	–	–	4	4
Current heat loss at $I_{th}$							
per contact		max.	W	0,3	–	–	–
<b>Contacts, UL/CSA Data</b>							
Pilot duty				A 300	–	B 300 / R 300	B 300
General Use rating				10A 250 V AC	–		

**Notes**

<sup>1)</sup> Making and breaking conditions to DC-13, L/R time constant as stated

# TP Timer Modules, V Latching Modules, VS Interface Modules

## Technical Data

				TPE 11 DIL TPD 11 DIL	V DIL	VS 1 DIL VS 2 DIL	ETS4-VS 3
<b>Magnet systems</b>							
Voltage tolerance							
AC operated							
Single-voltage coil 50 Hz and dual-voltage coil 50 Hz, 60 Hz	unlatching	$x U_c$	–	–	0,8 – 1,1	–	
Dual-voltage coil ... V, 50/60 Hz	unlatching	$x U_c$	–	–	0,8 – 1,1	–	
DC operated <sup>1)</sup>							
	pick-up	$x U_c$	–	–	0,75 – 1,25	0,85 – 1,2	
	unlatching	$x U_c$	–	0,85 – 1,1	–	–	
Power consumption							
AC operated							
Single-voltage coil 50 Hz and dual-voltage coil 50 Hz, 60 Hz	pull-in	VA/W	–	13/12	–	–	
	sealing	VA/W	–	5/2	–	–	
DC operated	pull-in = sealing	W	–	26	0,27	0,6	
Duty factor			% DF	100	100 at AC 200 ms at DC	100	100
Switching times 100 % U (approximate values)							
DC operated							
	closing delay	ms	–	–	6	7	
	opening delay	ms	–	–	2,5	3	
Minimum command time							
AC operated 50 Hz							
	latching	ms	–	35	–	–	
	unlatching	ms	–	25	–	–	
DC operated							
	latching	ms	–	45	–	–	
	unlatching	ms	–	25	–	–	
Repetition accuracy			%	< 3 (5)	–	–	–
Time deviation in relation to ambient temperature based on +20 °C				0,2 %/K	–	–	–
Long-time deviation				15 %	–	–	–
Recovery time (after 100% time delay)			ms	20	–	–	–
Mechanical lifespan			coil 50/60 Hz	at 50-Hz, approximately 30% less than shown under "General"			

**Notes**

<sup>1)</sup> smoothed DC or three-phase bridge rectifier

## DIL ET, ETR 4 Timing Relays

### Technical Data

				DIL ET-A	ETR 4-A
<b>General</b>					
Standards				CSA, UL, IEC/EN 60 255, VDE 0435, IEC/EN 60 947	
Mechanical lifespan					
AC operated	operations	x 10 <sup>6</sup>	30	30	
DC operated	operations	x 10 <sup>6</sup>	30	30	
Climatic proofing				Damp heat, constant, to IEC 60 068-2-3 Damp heat, cyclical, to IEC 60 068-2-30	
Ambient temperature					
open	min./max.	°C	-20/+60	-25/+60	
enclosed	min./max.	°C	-20/+45	-20/+45	
Mounting position				as required	
Mechanical shock resistance (sinusoidal shock 20 ms)		N.O. contact	g	4	4
Degree of protection		terminals		IP 20	IP 20
Dimensions				→ page 02/056	
Weight			kg	0,09	0,1
Terminal capacity				→ page 02/040 (as DIL EF)      → page 02/043 (as ETS4 VS3)	
<b>Contacts, IEC Data (EN 60 947)</b>					
Rated impulse withstand voltage $U_{imp}$			V AC	6000	6000
Overvoltage category / pollution degree				III/2	III/3
Rated insulation voltage $U_i$			V AC	600	600
Rated operational voltage $U_e$			V AC	440	440
Safe isolation to IEC 536 between coil and auxiliary contacts, and between the auxiliary contacts			V AC	250	250
<b>Making capacity</b>					
AC-14	cos $\varphi = 0,3$	440 V	A	48	48
AC-15	cos $\varphi = 0,3$	220 V	A	50	50
DC-11	L/R ≤ 40 ms		x $I_e$	1,1	1,1
<b>Breaking capacity</b>					
AC-14	cos $\varphi = 0,3$	440 V	A	3	3
AC-15	cos $\varphi = 0,3$	220 V	A	3	3
DC-11	L/R ≤ 40 ms		x $I_e$	1,1	1,1
<b>Rated operational current <math>I_e</math></b>					
AC-14		440 V	A	3	3
AC-15		220 V	A	3	3
DC-11 <sup>1)</sup>	Above 110V and at L/R > 15 ms: it is essential that an arc-quenching device (FC suppressor) be used in parallel with the contacts. C: 1 $\mu$ F, R: 0,5 $\Omega$ in series				
	L/R ≤ 15 ms: e.g. contactor coils, solenoid valves, DC motors				
	24 V		A	1,5	1,5
	L/R ≤ 50 ms:				
			A	1,2	1,2
Conventional free air thermal current $I_{th}$			A	6	6
<b>Short-circuit rating<sup>2)</sup> without welding</b>					
Maximum fuse			A gL/gG	6	6
<b>Contacts, UL/CSA Data</b>					
Flot duty				B 300	B 300
General Use rating				6A, 250 V AC	

**Notes**

<sup>1)</sup> Making and breaking conditions to DC-11, L/R time constant as stated

<sup>2)</sup> When taken directly from mains or transformer > 1000 VA

# DIL ET, ETR 4 Timing Relays

## Technical Data

			DIL ET-A	ETR 4-A
<b>Magnet system</b>				
Voltage tolerance				
AC operated 50/60 Hz				
	pick-up		→ page 02/017	→ page 02/019
DC operated when taken directly from mains or transformer > 1000 VA				
	pick-up		→ page 02/017	→ page 02/019
Power consumption				
AC operated 50/60 Hz				
	pull-in	V <sub>AW</sub>	2/-	2/-
	sealing	V <sub>AW</sub>	2/-	2/-
DC operated				
	pull-in	W	1,8	1,8
	sealing	W	1,8	1,8
Duty factor			% ED	100
Max. operating frequency			Ops./h	4000
Min. command time			AC/DC	ms
Voltage variation				0,01% Δ U
Variation due to temperature fluctuation based on +20 °C				0,025
Repetition accuracy			%	0,1
Recovery time (after 100% time delay)			ms	70
Contact changeover time $t_u$			ms	-
				4 (50) <sup>1)</sup>

Notes

<sup>1)</sup> ETR4-51

## ESR Electronic Safety Relays

### Technical Data

				ESR3-NO-31	ESR4-NO-31	ESR4-NO-21
<b>General</b>						
Standards				UL, CSA, IEC/EN 60 947, VDE 0660, IEC/EN 60 255		
Mechanical lifespan	operations	$\times 10^6$	10	10	10	
Max. operating frequency		Ops/h	3600	3600	3600	
Climatic proofing				Damp heat DIN 50 016: 24 hour cycle, 23 °C, 83% relative humidity, 40 °C, 92% relative humidity		
Ambient temperature	min./max.	°C	-25/+55	-25/+55	-25/+55	
Storage temperature	min./max.	°C	-25/+70	-25/+70	-25/+70	
Mounting position				as required	as required	as required
Vibration resistance				g, 5, to IEC/EN 60 068-2-6, frequency: 10 – 55 Hz, amplitude: 0,35 mm		
Degree of protection						
Enclosure				IP 40	IP 40	IP 40
Terminals				IP 20	IP 20	IP 20
Protection against direct contact from the front when actuated by perpendicular test finger (IEC 536)				finger and back-of-hand proof		
Dimensions				page 02/056	page 02/056	page 02/056
Weight				kg	0,36	0,2
Terminal capacity						
flexible with ferrule				mm <sup>2</sup>	1 x (0,5 – 1,5) 2 x (0,5 – 1,5)	1 x (0,25 – 2,5) 2 x (0,25 – 0,5)
solid				mm <sup>2</sup>	1 x (0,75 – 2,5) 2 x (0,75 – 2,5)	1 x (0,14 – 2,5) 2 x (0,14 – 0,75)
Terminal screws						
Požidriv screwdriver				size	2	–
Standard screwdriver				mm	–	0,6 x 3,5
Tightening torque				Nm	1	0,6
<b>Main circuits</b>						
Rated impulse withstand voltage $U_{imp}$				V AC	4000	4000
Overvoltage category / pollution degree					III/ 3 external, 2 internal	III/ 3 external, 2 internal
Rated insulation voltage $U_i$				V AC	300	300
Rated operational voltage $U_o$				V AC/DC	230	230
Rated operational current $I_o$						
AC-15				230 V	A	6
DC-13				24 V (360 Cps/h)	A	6
				24 V (3600 Cps/h)	A	3
Max. summation current of all poles				A	18	12
Short-circuit protection						
Fuse				A gl/gG	6	6

# ESR Electronic Timing Relays

## Technical Data

ESR4-NV3(30)-30 ESR4-NT30-30	ESR4-NM-21	ESR4-NZ-21	ESR4-NE-42	ESR4-VE3-42
UL, CSA, IEC/EN 60 947, VDE0660, IEC/EN 60 255				
10	10	10	10	10
3600	3600	3600	3600	3600
Damp heat 24 DIN 50 016: 24 hour cycle, 23 °C, 83% relative humidity, 40 °C, 92% relative humidity				
-25/+55	-25/+55	-25/+55	-25/+55	-25/+55
-25/+70	-25/+70	-25/+70	-25/+70	-25/+70
as required	as required	as required	as required	as required
5, to IEC/EN 60 068-2-6, frequency: 10 – 55 Hz, amplitude: 0,35 mm				
IP40	IP40	IP40	IP40	IP40
IP20	IP20	IP20	IP20	IP20
finger and back-of-hand proof				
page 02/056	page 02/056	page 02/056	page 02/056	page 02/056
0,2	0,2	0,2	0,2	0,2
1 x (0,25 – 2,5) 2 x (0,25 – 0,5)	1 x (0,25 – 2,5) 2 x (0,25 – 0,5)	1 x (0,25 – 2,5) 2 x (0,25 – 0,5)	1 x (0,25 – 2,5) 2 x (0,25 – 0,5)	1 x (0,25 – 2,5) 2 x (0,25 – 0,5)
1 x (0,14 – 2,5) 2 x (0,14 – 0,75)	1 x (0,14 – 2,5) 2 x (0,14 – 0,75)	1 x (0,14 – 2,5) 2 x (0,14 – 0,75)	1 x (0,14 – 2,5) 2 x (0,14 – 0,75)	1 x (0,14 – 2,5) 2 x (0,14 – 0,75)
–	–	–	–	–
0,6 x 3,5	0,6 x 3,5	0,6 x 3,5	0,6 x 3,5	0,6 x 3,5
0,6	0,6	0,6	0,6	0,6
4000	4000	4000	4000	4000
III/ 3 external, 2 internal	III/ 3 external, 2 internal	III/ 3 external, 2 internal	III/ 3 external, 2 internal	III/ 3 external, 2 internal
300	300	300	300	300
230	230	230	230	230
6	6	6	6	6
6	6	6	6	6
3	3	3	3	3
12	12	12	12	12
6	6	6	6	6

## ESR Electronic Safety Relays

### Technical Data

				ESR3-NO-31	ESR4-NO-31	ESR4-NO-21
<b>Operation</b>						
Actuating voltage $U_c$		V AC		230	24	24
		V DC		–	24	24
Voltage tolerance	pick-up	$x U_c$		0,85 – 1,1	0,85 – 1,1	0,85 – 1,1
<b>Power consumption</b>						
	AC operated 50/60 Hz	VA/W		3,2/2,5	2,4/1,4	3,5/2,1
	DC operated	W		–	1,3	1,5
<b>Control circuit</b>						
Rated output voltage		V DC		≤ 24	≤ 24	≤ 24
No-load voltage		V DC		≤ 40	–	–
Rated current		mA		40	40	50
Short-circuit current		A		1	1,4	2,2
Fuse				short-circuit protected transformer	PTC resistor	PTC resistor
Response time		ms		–	2000	2000
Recovery time		ms		–	3000	3000
<b>Inputs</b>						
Rated current		mA		Y13, Y14: 40 Y12, Y31: 15	Y2: 40	S12: 30 S31, S22: 20
Response time $t_{A1}$ (with reset monitoring)		ms		80	–	80
Response time $t_{A1}$ (without reset monitoring)		ms		500	50	60
Release time $t_R/t_{R1}$		ms		50/100	40	40/100
Min. contact dosing time $t_M$		ms		50	50	50
Recovery time $t_W$		ms		500	< 50	500
Synchronous monitoring time $t_S$		ms		–	–	–
<b>EMC</b>						
Emitted interference				to EN 50 081-1 and EN 50 081-2		
Noise immunity				to EN 50 082-2		

## ESR Electronic Timing Relays

### Technical Data

ESR4-NV(30)-30 ESR4-NT30-30	ESR4-NM-21	ESR4-NZ-21	ESR4-NE-42	ESR4-VE3-42
–	–	24	24	–
24	24	24	24	24
0,85 – 1,1	0,85 – 1,1	0,85 – 1,1	0,85 – 1,1	0,85 – 1,1
–	–	2,7/1,6	2,7/1,5	–
2,5	2,7	1,5	1,0	1,0
≤ 24	≤ 24	≤ 24	–	–
–	–	–	–	–
50	50	60	–	–
2,2	0,1	1	–	–
PTC resistor	Electronic protection	PTC resistor	–	–
2000	5	2000	–	–
3000	5	3000	–	–
S12, S22, S31: 25 S34, S35: 40	S12: 30 S31, S22: 20	Y2: 60 Y11, Y21: 60	–	–
30	80	–	–	–
200	60	40	25	25
25/adjustable	40/100	< 50	15	–
200	50	–	–	–
500	500	< 250	–	–
–	–	< 500	–	–
to EN 50 081-1 and EN 50 081-2				
to EN 50 082-2				

# DILER, DILR Industrial Control Relays

## Dimensions

### DILER control relays

DILER...  
DILER...-G



DILER... + ...DILE  
DILER...-G+ ...DILE

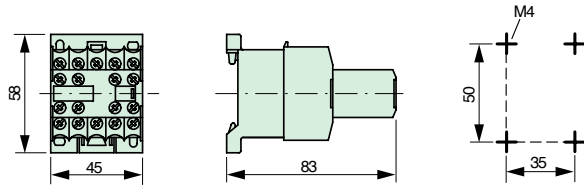

DILER... + HDILE  
DILER...-G+ HDILE

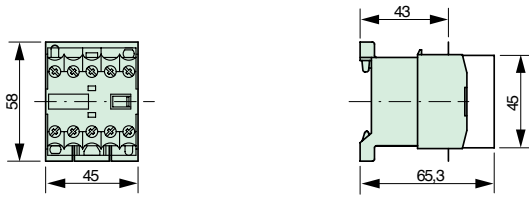

2 DILER... + MVDILE  
2 DILER...-G+ MVDILE

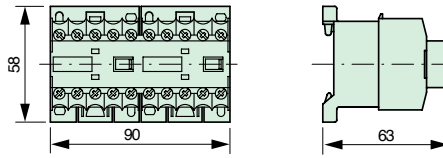

DILER... + FCDILE  
DILER...-G+ VGDILE

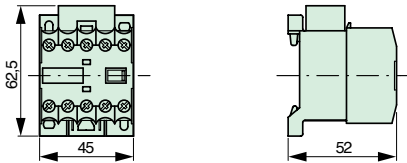

2 DILER... + MVDILE + ...DILE  
2 DILER...-G+ MVDILE + ...DILE

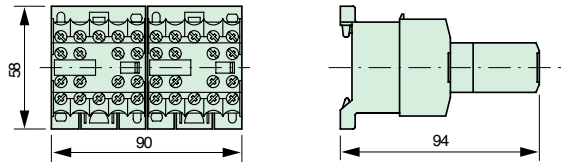

DILER... + TDDILE24

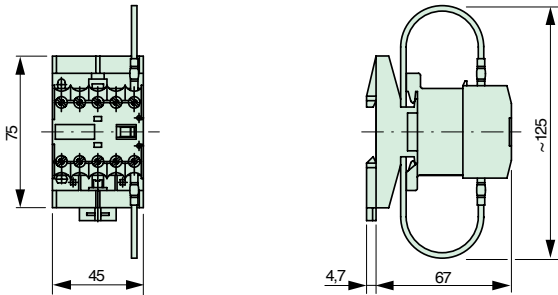

Remote Potentiometer  
FR-10

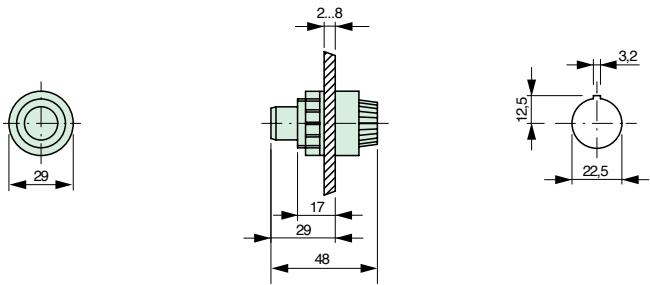

### Suppressors, Interface Modules

FCBDIL  
FDBDIL  
VGBDIL  
VS1(2) DIL

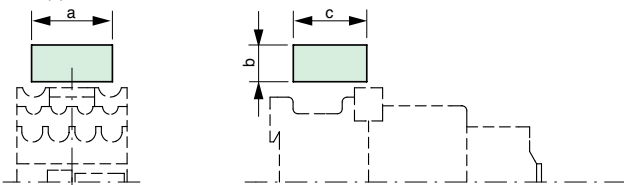

	FCBDIL	FDBDIL	VGBDIL	VS1 DIL	VS2 DIL
a	33	33	33	45	45
b	15	15	15	26	26
c	30	30	30	55	55

### Electronic Timing Relays

ETR4-11...  
ETR4-51...  
ETR4-69...  
ETR4-70...

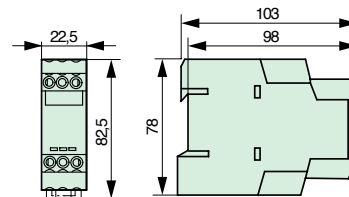

# DIL R Control Relays, DIL ET, ETR4 Electronic Timing Relays Dimensions

## Control Relays

DIL R22(-G)  
DIL R22D(-G)  
DIL R31(-G)  
DIL R40(-G)

DIL R22(-G) + ...DIL  
DIL R31(-G) + ...DIL  
DIL R40(-G) + ...DIL  
DIL R44D(-G)  
DIL R53D(-G)

DIL R22(-G) + TFE (TFD) 11 DIL  
DIL R31(-G) + TFE (TFD) 11 DIL  
DIL R40(-G) + TFE (TFD) 11 DIL

DIL R22(-G) + V(-G) DIL  
DIL R31(-G) + V(-G) DIL  
DIL R40(-G) + V(-G) DIL

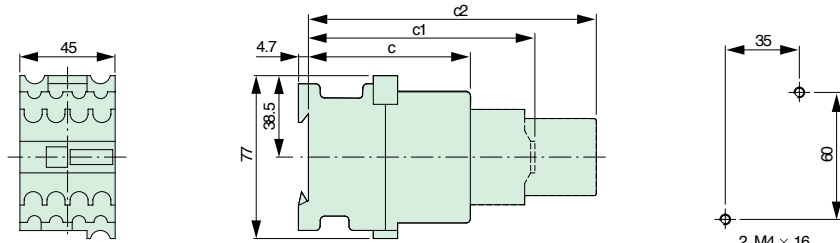

DIL R22 (-G)	DIL R22+...DIL (-G)	DIL R22+TFE11 DIL (-G)	DIL R22+V DIL (-G)
DIL R31 (-G)	DIL R31+...DIL (-G)	DIL R22+TFD11 DIL (-G)	DIL R31+V DIL (-G)
DIL R40 (-G)	DIL R40+...DIL (-G)	DIL R31+TFE11 DIL (-G)	DIL R40+V DIL (-G)
DIL R22D (-G)	DIL R44D (-G)	DIL R31+TFD11 DIL (-G)	
	DIL R53D (-G)	DIL R40+TFE11 DIL (-G)	
		DIL R40+TFD11 DIL (-G)	

c (w HDIL)	76,5	(101,5)	-	-	-	-	-
c (w/o HDIL)	74	(99)	-	-	-	-	-
c1	-	-	107	(132)	-	-	-
c2	-	-	-	-	136	161	137 162

c1 = with ...DIL auxiliary contact module or DIL R...D(-G) complete unit  
c2 = with V(-G) DIL mechanical latching module or with TP...11 DIL pneumatic timer module

## Electronic Timing Relays

DIL ET...

DILET... + HDILE

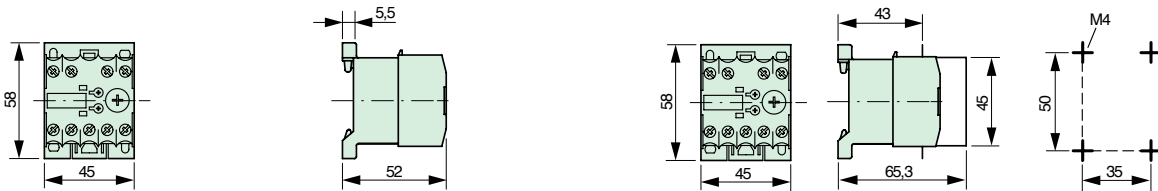

## Electronic Safety Relays

ESR3-NO-31 (230 V)

ESR4-NO-31  
ESR4-NO-21  
ESR4-NM-21  
ESR4-NZ-21  
ESR4-NV3(30)-30  
ESR4-NT30-30  
ESR4-NE-42  
ESR4-VE3-42

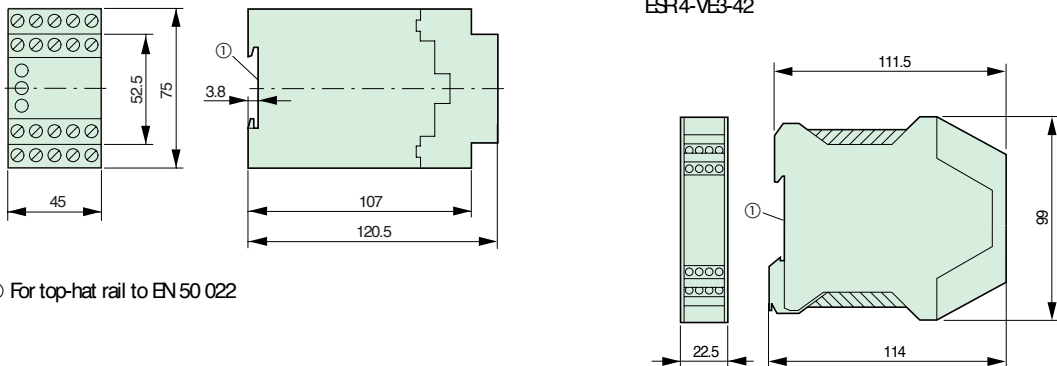

① For top-hat rail to EN 50 022