

# Compact PLCs

CPM1A Compact PLCs	40
Dimensions	48
Specifications	50
Ordering Information	57
CPM2-series Overview	59
CPM2A Compact PLCs	65
Specifications	66
Analog I/O units	70
Fieldbus Units	73
Dimensions	77
Ordering Information	80
CPM2B Board PLCs	82
Specifications	84
CPM2C Compact PLCs	86
Specifications	90
CPU Units with master function	93
AC Power Supply Unit	100
Analog I/O Units	101
Communications Units	103
Fieldbus Units	107
Dimensions	109
Ordering Information	112
CP1H Compact PLCs	116
Specifications	129
Dimensions	131
Ordering Information	131

Compact PLC series

# CPM1A

Ultracompact and Economical ... For a Wide Range of Uses  
AC or DC power, relay or transistor outputs, sourcing or sinking, etc.

## SYSMAC CPM1A

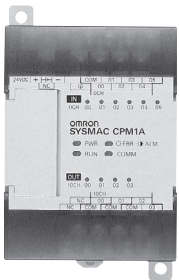

Setting a standard for micro PLCs, the CPM1A packs all basic functions into a compact size. Four CPU sizes are available, each with a choice of AC or DC power, relay or transistor outputs. Select any combination of power supply, output, and the number of I/O points to meet your needs.

**AC Power Source CPU Units** Depth: 70 mm

<p>■Relay Output CPU Unit CPM1A-10CDR-A-V1</p> <p>■Transistor Output CPU Units CPM1A-10CDT-A-V1 (Sink) CPM1A-10CDT1-A-V1 (Source)</p> <ul style="list-style-type: none"> <li>●Input points: 6, DC input</li> <li>●Output points: 4</li> </ul>	<p>■Relay Output CPU Unit CPM1A-20CDR-A-V1</p> <p>■Transistor Output CPU Units CPM1A-20CDT-A-V1 (Sink) CPM1A-20CDT1-A-V1 (Source)</p> <ul style="list-style-type: none"> <li>●Input points: 12, DC input</li> <li>●Output points: 8</li> </ul>
<p>■Relay Output CPU Unit CPM1A-30CDR-A-V1</p> <p>● Transistor Output CPU Units CPM1A-30CDT-A-V1 (Sink) CPM1A-30CDT1-A-V1 (Source)</p> <ul style="list-style-type: none"> <li>●Input points: 18, DC input</li> <li>●Output points: 12</li> </ul>	<p>■Relay Output CPU Unit CPM1A-40CDR-A-V1</p> <p>■Transistor Output CPU Units CPM1A-40CDT-A-V1 (Sink) CPM1A-40CDT1-A-V1 (Source)</p> <ul style="list-style-type: none"> <li>●Input points: 24, DC input</li> <li>●Output points: 16</li> </ul>

**DC Power Source CPU Units** Depth: 50 mm

<p>■Relay Output CPU Unit CPM1A-10CDR-D-V1</p> <p>■Transistor Output CPU Units CPM1A-10CDT-D-V1 (Sink) CPM1A-10CDT1-D-V1 (Source)</p> <ul style="list-style-type: none"> <li>●Input points: 6, DC input</li> <li>●Output points: 4</li> </ul>	<p>■Relay Output CPU Unit CPM1A-20CDR-D-V1</p> <p>■Transistor Output CPU Units CPM1A-20CDT-D-V1 (Sink) CPM1A-20CDT1-D-V1 (Source)</p> <ul style="list-style-type: none"> <li>●Input points: 12, DC input</li> <li>●Output points: 8</li> </ul>
<p>■Relay Output CPU Unit CPM1A-30CDR-D-V1</p> <p>■Transistor Output CPU Units CPM1A-30CDT-D-V1 (Sink) CPM1A-30CDT1-D-V1 (Source)</p> <ul style="list-style-type: none"> <li>●Input points: 18, DC input</li> <li>●Output points: 12</li> </ul>	<p>■Relay Output CPU Unit CPM1A-40CDR-D-V1</p> <p>■Transistor Output CPU Units CPM1A-40CDT-D-V1 (Sink) CPM1A-40CDT1-D-V1 (Source)</p> <ul style="list-style-type: none"> <li>●Input points: 24, DC input</li> <li>●Output points: 16</li> </ul>

**Expansion I/O Units**

<p>CPM1A-8ED</p> <ul style="list-style-type: none"> <li>●Input points: 8, DC input</li> </ul> <p>CPM1A-8ER</p> <ul style="list-style-type: none"> <li>●Output points: 8, RY output</li> </ul> <p>CPM1A-8ET</p> <ul style="list-style-type: none"> <li>●Output points: 8, TR output (Sink)</li> </ul> <p>CPM1A-8ET1</p> <ul style="list-style-type: none"> <li>●Output points: 8, TR output (Source)</li> </ul>	<p>CPM1A-20EDR1</p> <ul style="list-style-type: none"> <li>●Input points: 12, DC input</li> <li>●Output points: 8, RY output</li> </ul> <p>CPM1A-20EDT</p> <ul style="list-style-type: none"> <li>●Input points: 12, DC input</li> <li>●Output points: 8, TR output (Sink)</li> </ul> <p>CPM1A-20EDT1</p> <ul style="list-style-type: none"> <li>●Input points: 12, DC input</li> <li>●Output points: 8, TR output (Source)</li> </ul>
--	--

**Temperature Sensor Units**

CPM1A-TS001

- Thermocouple inputs: 2

CPM1A-TS002

- Thermocouple inputs: 4

CPM1A-TS101

- Pt100 inputs: 2

CPM1A-TS-101-DA

- Pt100 inputs: 2, Analog outputs: 1

CPM1A-TS102

- Pt100 inputs: 4

**Analog I/O Units**

CPM1A-MAD01 (Resolution: 256)

CPM1A-MAD11 (Resolution: 6,000)

2 inputs + 1 output

CPM1A-AD041 (4 inputs)

CPM1A-DA041 (4 outputs)

**DeviceNet**

CPM1A-DRT21

- I/O Link inputs: 32
- I/O Link outputs: 32

**PROFIBUS-DP**

PROFIBUS-DP I/O Link Unit

CPM1A-PRT21

- I/O Link inputs: 16
- I/O Link outputs: 16

**CompoBus/S**

CompoBus/S I/O Unit

CPM1A-SRT21

- I/O Link inputs: 8
- I/O Link outputs: 8

Space-saving Integration for Compact machines and Small-scale Control cabinets

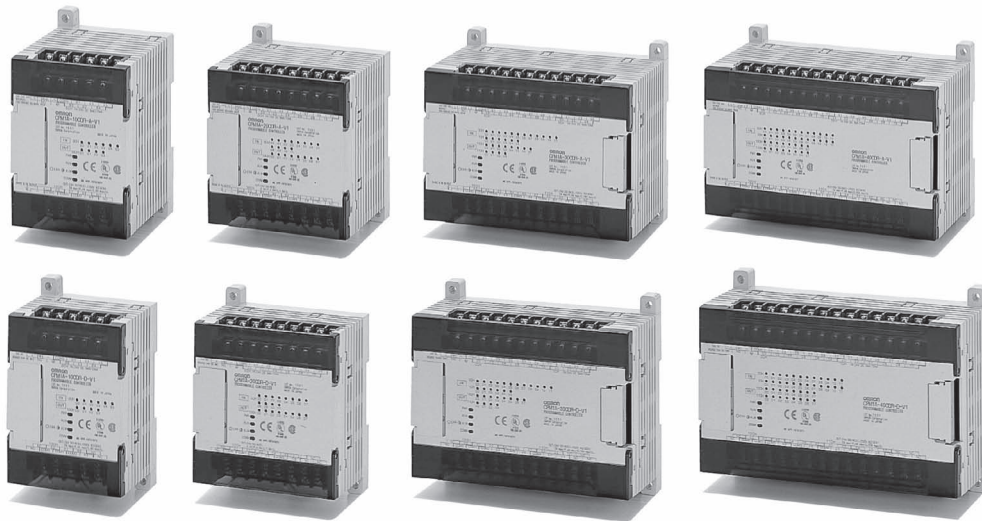

- **Ultracompact Size**  
Ten-I/O-point AC models measure only 90 mm x 66 mm x 70 mm (H x W x D), and contain all basic PLC functions.
- **A Wide Variety of Models Handling from 10 to 100 I/O Points**  
By combining CPU Units having from 10 to 40 I/O points with 20-I/O-point Expansion I/O Units, CPM1A PLCs can be configured for 10 to 100 I/O points.
- **Programming by Programmable Terminal**  
Use of the optional Communications Adapter (RS-232C or RS-422 conversion) enables fast Host Link or NT Link communications with an OMRON Programmable Terminal. This makes it possible to program the CPM1A on the PT screen, greatly simplifying maintenance tasks.
- **High-speed Processing**  
Processing is fast, e.g., 0.7- $\mu$ s AND LD / OR LD and 16.3- $\mu$ s MOV instructions, allowing high-speed execution of even lengthy programs. Integrated interrupt and pulse catch inputs also handle high-speed pulses that occur within one program cycle.
- **Versatile Functions in a Compact Body**  
A large program capacity and instruction list handle even complicated control tasks with ease.
  - User memory: 2,048 words
  - Data memory: 1,024 words
  - Timer/counter: 128 points
  - Basic instructions: 14 types
  - Application instructions: 79 types
  - Analog setting dials: 2 points (built-in)
- **Pulse Output**  
CPM1A CPU models with transistor outputs can output pulses with a maximum frequency of 2 kHz. Combining these models with a Stepping Motor Driver or Servo Driver enables easy positioning operation.

**Application Example**

Changing the speed of a stepping motor.

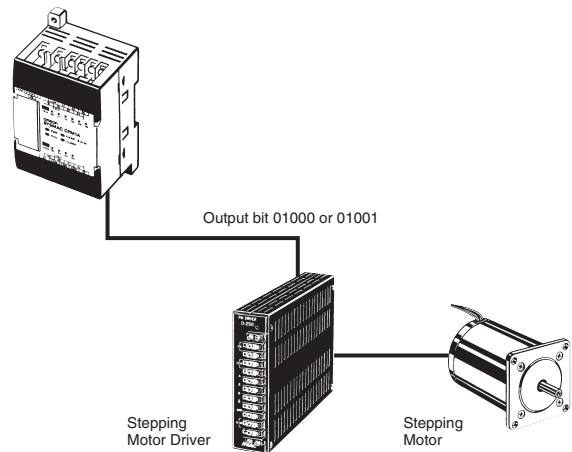

**Functions**

**Input Interrupts**

There are two input interrupts in the CPM1A 10-point I/O CPU and four in the 20-, 30-, and 40-point I/O CPUs. Input interrupts are available in two modes.

**10-point I/O CPU**

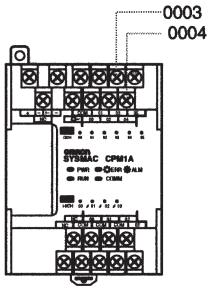

**20-, 30- and 40-point I/O CPU**

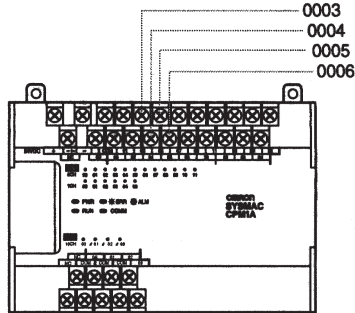

**Application Example:**

**Cutting Metal Sheets to Specified Lengths**

The proximity sensor detects the edge of a metal plate to operate the cutter. Metal sheets can be cut continuously to the specified lengths at a high speed.

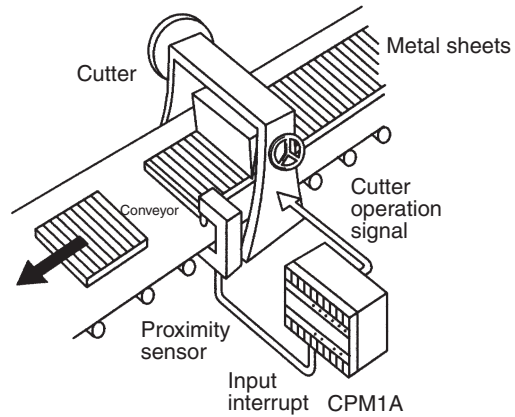

**Input Interrupt Mode**

If an input interrupt occurs, the regular program shuts down irrelevant of the cycle time, and the interrupt processing program is executed immediately.

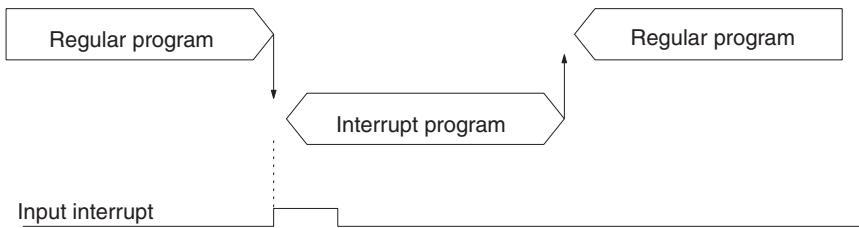

**Counter Mode**

When the number of external signals counted at high speed reaches a specified number of counts, the regular program shuts down, and the interrupt processing program is executed at fixed counts. The count can be set between 0 and 65535.

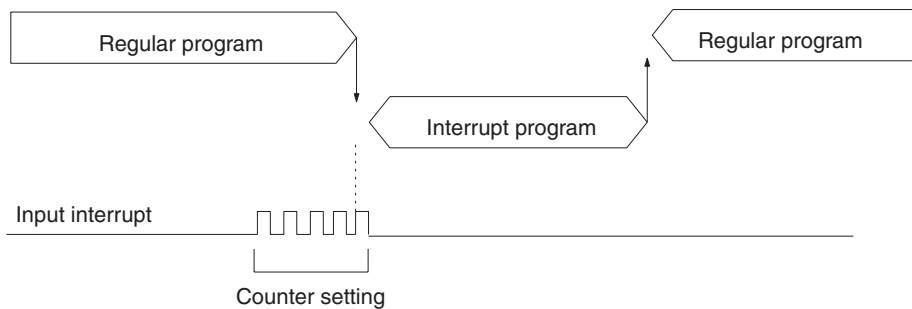

### Quick-response Inputs

There are two quick-response inputs for the CPM1A 10-point I/O CPU and four for the 20-, 30-, and 40-point I/O CPU (shared with the interrupt inputs). Since an internal buffer is provided, the quick-response input function can even detect signals modified within one cycle.

CPU	Input no.	Minimum input pulse width
10-point I/O CPU	00003 to 00004	0.2 ms
20-point, 30-point, 40-point I/O CPU	00003 to 00006	

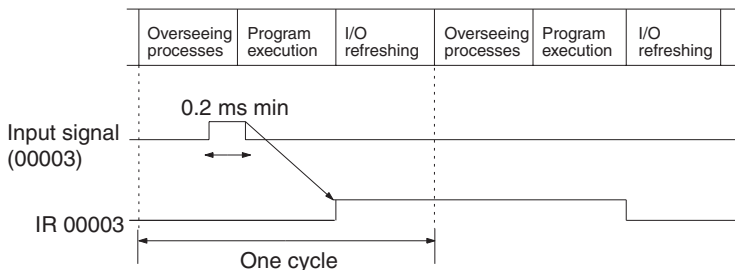

### Application Example:

#### Calculating the Number of Chips

The metal sensor counts the number of parts that have passed. Steady counting can be achieved even when the input-ON time is short.

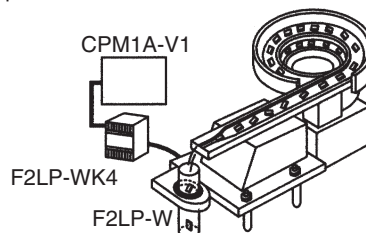

### High-speed Counter

The CPM1A has a high-speed counter function that can be used in the incrementing and up/down mode. Using this function together with the input interrupts enables zone comparison control or target value control irrelevant of the cycle time.

Item	Incrementing mode		Up/Down mode
Input no.	00000	Count input	A-phase input
	00001	---	B-phase input
	00002	Reset input	Z-phase input
Input method	Single-phase input		Phase-difference, 4 x inputs
Count frequency	5.0 kHz		2.5 kHz
Count range	0 to 65535		-32767 to 32767

**Note:** When using in the incrementing mode, the input 00001 can be used as an input contact.

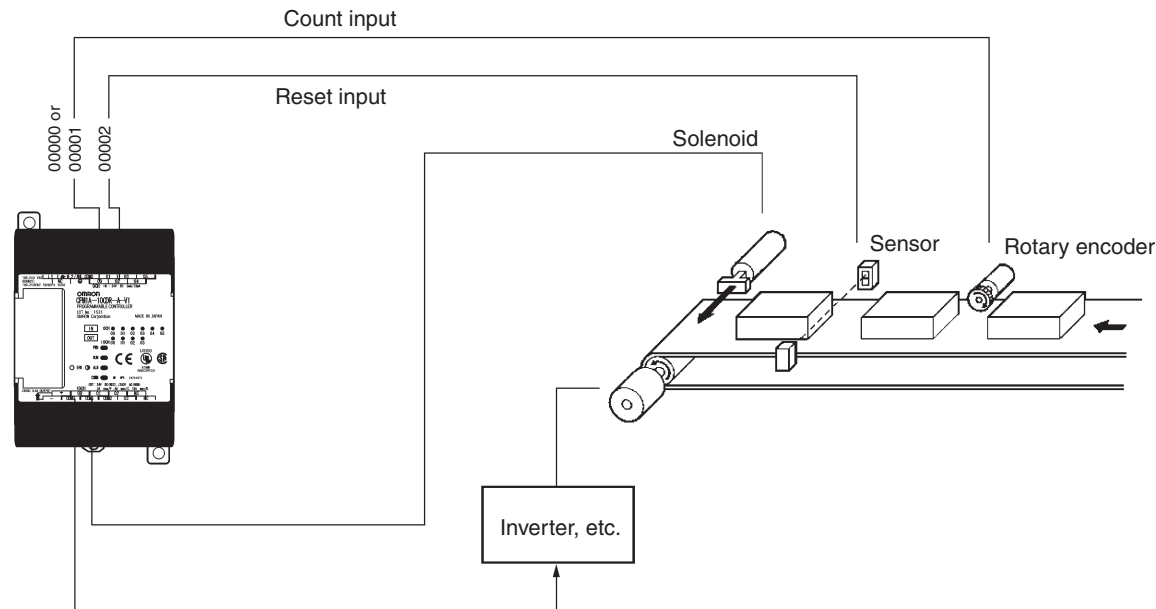

## Interval Timer Interrupts

The CPM1A has one interval timer. The interval timer shuts down the regular program irrelevant of the point in the cycle once the time is up, and immediately executes an interrupt processing program. Interval timers are used in the following two modes.

Item	One-shot mode	Scheduled interrupt mode
Operation	An interrupt is executed only once when the time is up.	Interrupts are executed repeatedly at fixed periods.
Setting time	0.5 ms to 319,968 ms (0.1-ms units)	

### Normal program

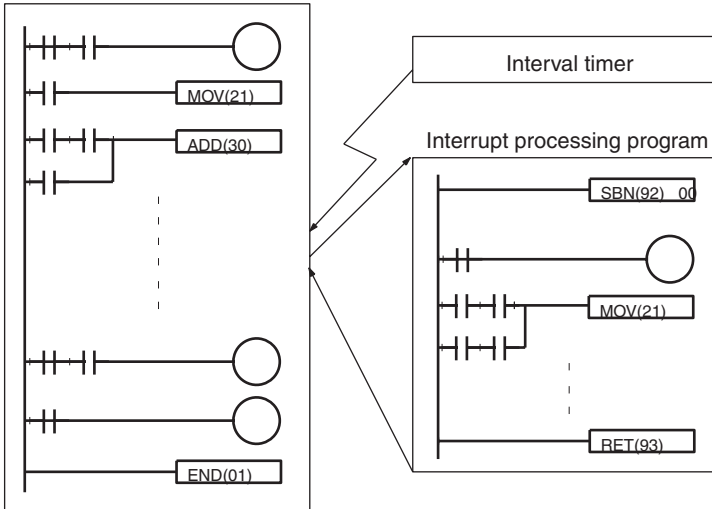

### Application example

#### Computing the Sheet Speed

The number of pulse inputs is computed in the interrupt mode at a fixed time to calculate the speed.

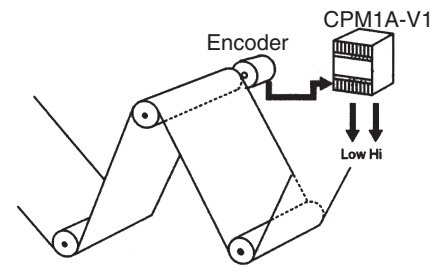

## Analog Setting

The CPM1A contains two analog setting controls that can be used for a broad range of analog timer and counter settings. Turning the setting control stores values of 0 to 200 (BCD data) in the SR area.

Analog setting	Storage area	Setting value (BCD)
Analog setting 0	SR 250	0000 to 0200
Analog setting 1	SR 251	

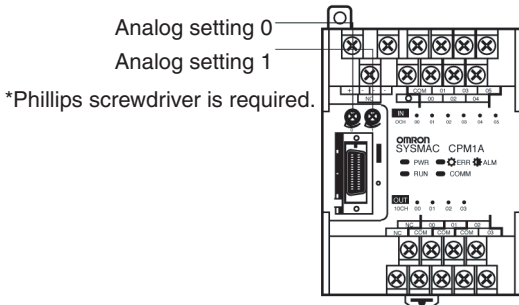

### Application Example:

#### Tact Operation Control of Conveyor Lines

A conveyor can be stopped temporarily as required for assembly processes. When the timer function and limit switches are used in a combination, conveyors can be stopped for a fixed time or can be run at a constant speed for a fixed distance. Fine adjustment of the stopping time can be easily done by using the analog setting controls.

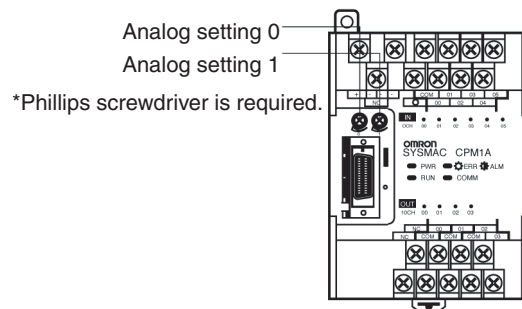

## Program Example

1. Analog timer for 0.0 to 20.0 seconds

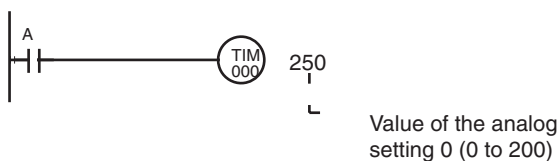

2. Analog timer for 0.0 to 60.0 seconds

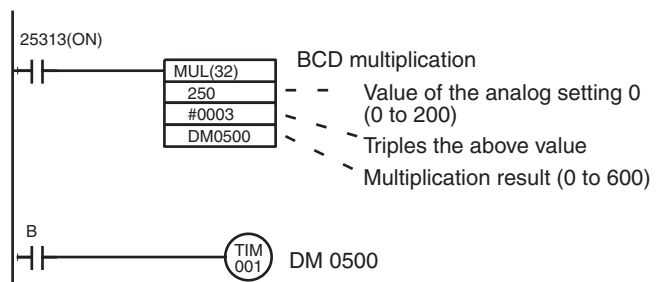

### Pulse Output Function

The CPM1A with transistor output has a function that is capable of outputting a pulse of up to 2 kHz.

When used in combination with a Stepping Driver or Servodriver, positioning can be easily performed.

### Application Example

Changing the speed of the Stepping Motor.

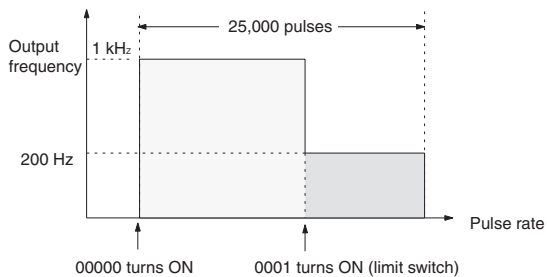
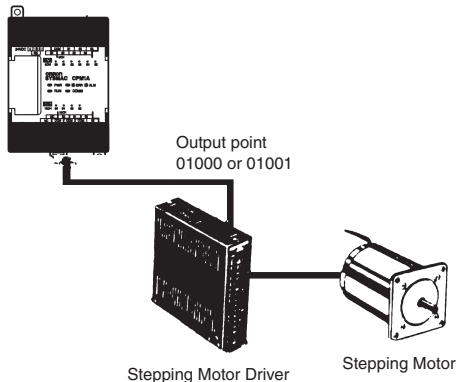

### Program Example

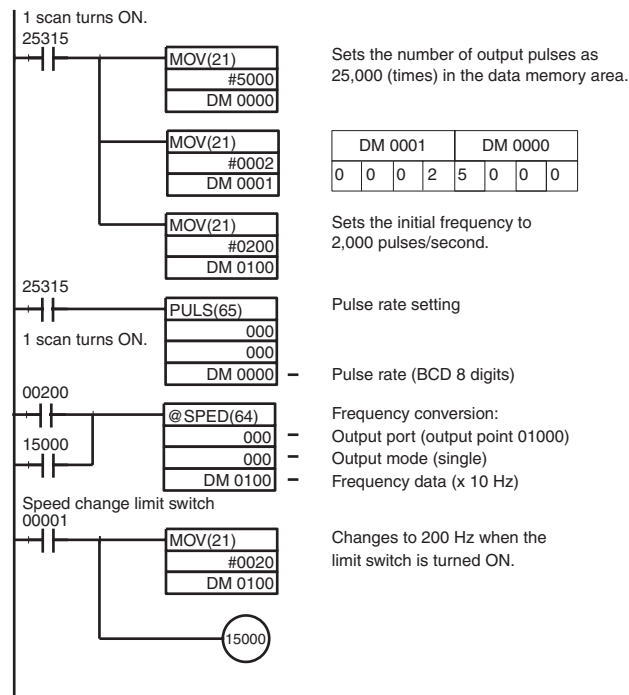

## Communications

### Host Link Communications

CPM1A host link communications consist of interactive procedures whereby the CPM1A returns a response to a command sent from the IBM PC/AT or compatible computer. These communications allow the IBM PC/AT or compatible computer to read and write in the CPM1A's I/O Areas and Data Memory Areas as well as in areas containing the status of various settings.

#### 1:1 Host Link Communications

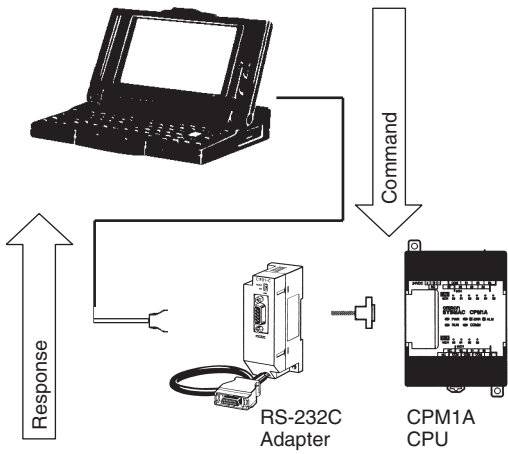

#### 1:n Host Link Communications

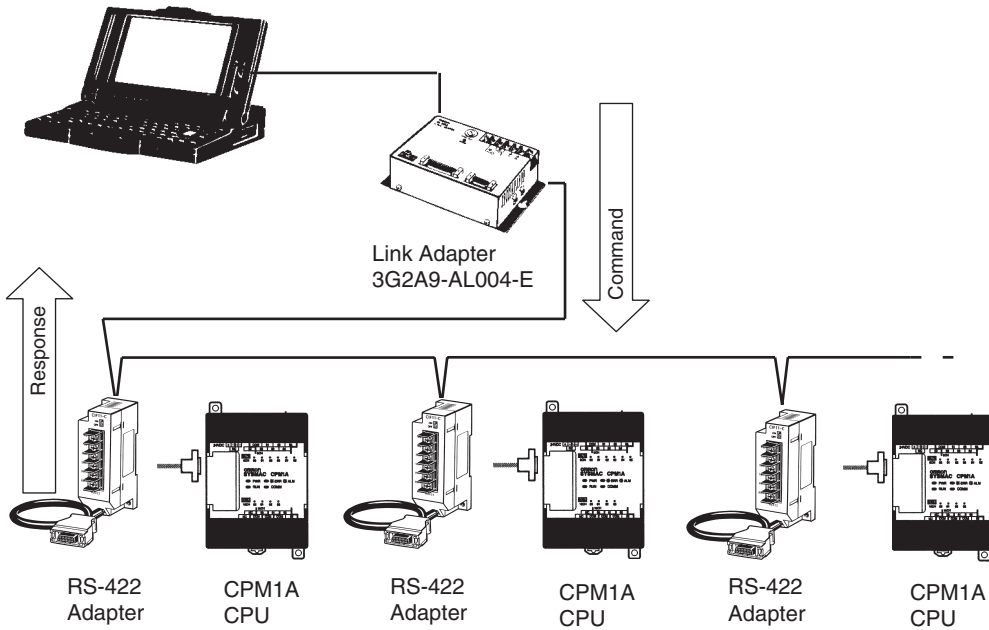

**1:1 Links**

With a 1:1 link, two CPM1As or a CPM1A and CQM1 or C200H□ are connected 1:1 with one side as the Master and the other as the Slave to provide an I/O link of a maximum of 256 points (LR 0000 to LR 1515).

**Example of a 1:1 Link between CPM1As**

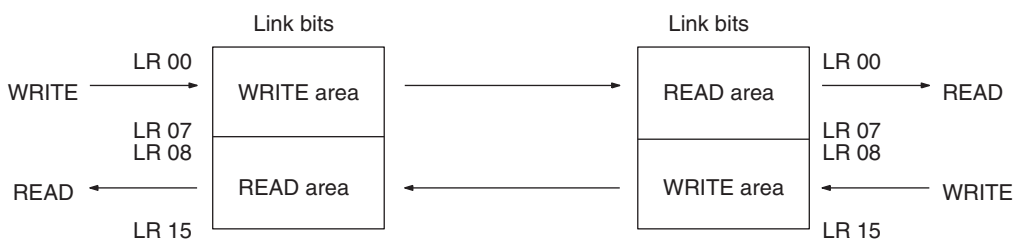
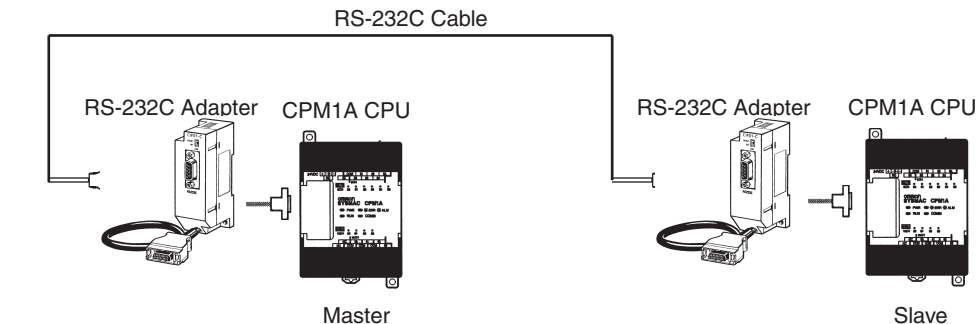

**Limitations of the CPM1A 1:1 Link**

CPM1A I/O links are limited to 16 words (LR 00 to LR 15). Therefore, use these 16 words (LR 00 to LR 15) on the CQM1 or C200H□ side when forming 1:1 links with a CQM1 or C200H□.

**NT Links**

High-speed communications can be achieved by providing a direct access through the use of the NT Link between the CPM1A and Programmable Terminal.

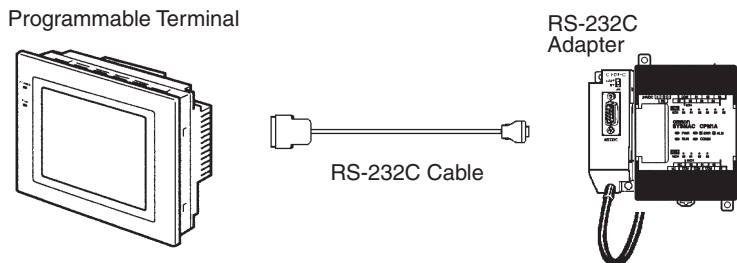

System Configuration

CPM1A Line-up

CPU with AC Power Supply • DC input • RY output / TR output  
 CPU with DC Power Supply • DC input • RY output / TR output

AC Power Supply Type DC Power Supply Type

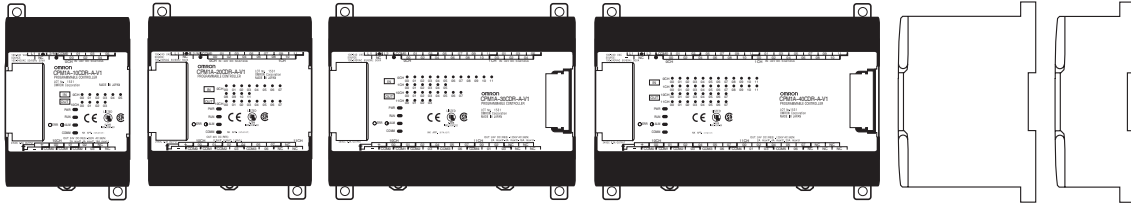

10 I/O points (Expansion not possible) 20 I/O points (Expansion not possible) 30 I/O points 40 I/O points

Expansion I/O Unit • DC input • RY output/TR output  
 Expansion I/O Unit • DC input • RY output/TR output  
 DeviceNet I/O Link Unit CPM1A-DRT21  
 PROFIBUS-DP I/O Link Unit CPM1A-PRT21  
 CompoBus/S I/O Link Unit CPM1A-SRT21  
 Analog I/O Unit CPM1A-MAD01 -MAD11 -AD041 -DA041  
 Temperature Sensor Units CPM1A- TS001 TS002 TS101 TS101-DA TS102

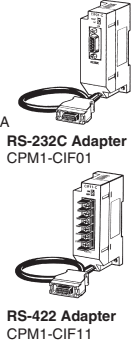
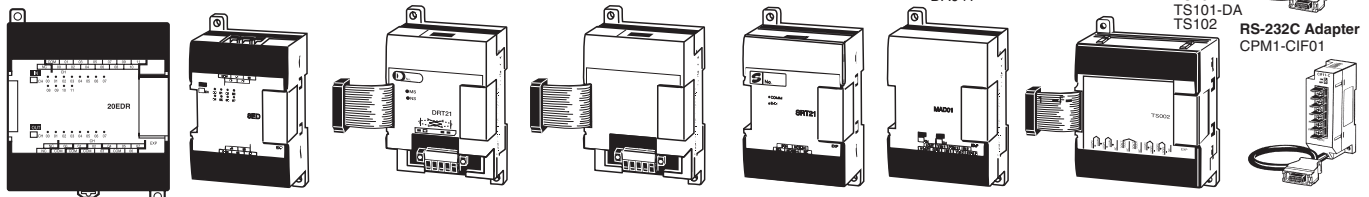

CPM1A System Configuration

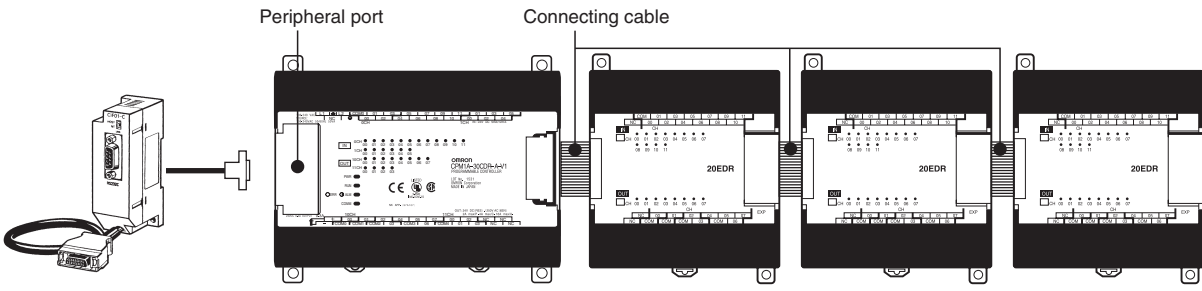

Both AC and DC power supplies. 30-point CPU and 40-point CPU only. May be expanded up to a maximum of 3 Units.

External Dimensions

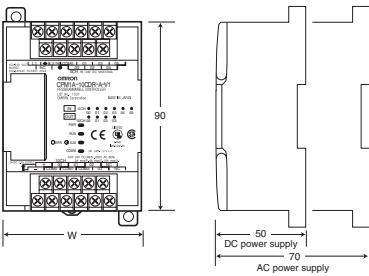

CPM1-CIF01

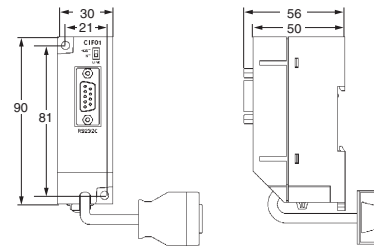

CPM1-CIF11

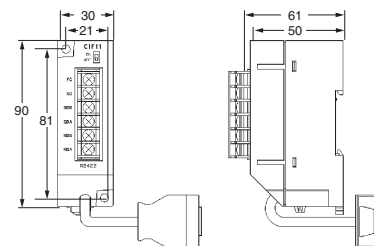

Model	W (mm)
CPM1A-10CD□-A-V1	66
CPM1A-10CD□-D-V1	66
CPM1A-20CD□-A-V1	86
CPM1A-20CD□-D-V1	86
CPM1A-30CD□-A-V1	130
CPM1A-30CD□-D-V1	130
CPM1A-40CD□-A-V1	150
CPM1A-40CD□-D-V1	150
CPM1A-20ED□	86 (depth: 50 mm)
CPM1A-8E□/SRT21	66 (depth: 50 mm)
CPM1A-MAD01/TS101-DA	66 (depth: 50 mm)
CPM1A-TS□□/MAD11	86 (depth: 50 mm)
CPM1A-DRT21/PRT21	66 (depth: 50 mm)
CPM1A-AD041/DA041	86 (depth: 50 mm)

### CPM1A System Configuration Example

A maximum of three Expansion I/O Units can be connected to the CPU Unit. Note that each 4-Channel Analog I/O Unit is counted as two Expansion Units (Group 2 Units, see Table 2).

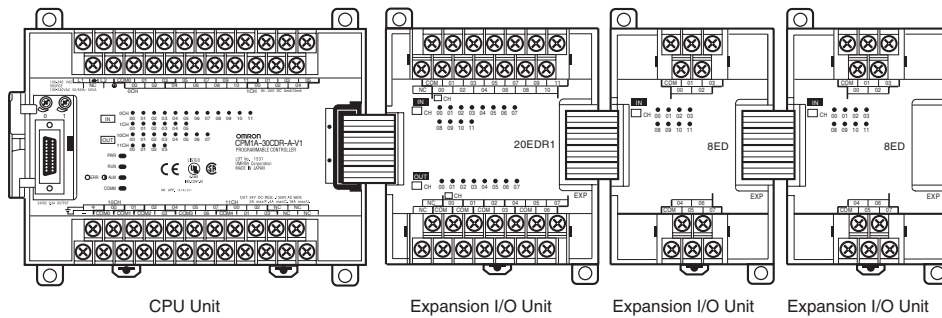

### Connection Groups for Expansion Units

Group 1 (G1)	Group 2 (G2)
Expansion I/O Units, Analog I/O Unit, CompoBus/S I/O Link Unit PROFIBUS-DP I/O Link Unit DeviceNet I/O Link Unit CPM1A-TS001/101(-DA)	CPM1A-TS002/102 CPM1A-AD041/DA041

In addition to the CPU Unit, Expansion Units from the groups indicated in the above table can be combined as shown below.

### Possible Expansion Unit Combinations

Expansion Unit 1	Expansion Unit 2	Expansion Unit 3
G1	G1	G1
G2	G1	---

- Note:**
- Expansion Units 1, 2, and 3 can be mounted in any order.
  - Only one Expansion Unit can be mounted if an NT-AL001 is connected to the RS-232C port.

### DC Power Supply-type CPM1A Power Consumption

Use the list below for calculating CPM1A power capacity. The CPM2C-PA201 AC Power Supply Unit provides 15 watts of power, so the remainder of the PLC power can be used as service power for sensors or other components.

CPM1A CPU Unit	Power Consumption (W)	Expandability
CPM1A-10CDR-D-V1	3.5	Not possible
CPM1A-20CDR-D-V1	4.5	Not possible
CPM1A-30CDR-D-V1	5.5	
CPM1A-40CDR-D-V1	6.5	
CPM1A-10CDT/T1-D-V1	3	Not possible
CPM1A-20CDT/T1-D-V1	3.5	Not possible
CPM1A-30CDT/T1-D-V1	4	
CPM1A-40CDT/T1-D-V1	4.5	

Add the following power consumption when using Expansion Units.

CPM1A CPU Unit	Power Consumption (W)
CPM1A-20EDR1	2.5
CPM1A-20EDT/T1	1.5
CPM1A-8ED	1
CPM1A-8ER	2
CPM1A-8ET/T1	1
CPM1A-SRT21/DRT21/PRT21	1
CPM1A-MAD01/MAD11	3.5
CPM1A-TS001/TS101(-DA)	3
CPM1A-TS002/TS102	3
CPM1A-AD041	3
CPM1A-DA041	3.3

The power consumption for the CPU Unit includes that of the Programming Console, RS-232C Adaptor, etc.

Specifications

General Specifications

Item		10-point I/O	20-point I/O	30-point I/O	40-point I/O
Power supply vol tage/fre- quency	AC power supply	100 to 240 V AC, 50/60 Hz			
	DC power supply	24 V DC			
Operating voltage range	AC power supply	85 to 264 V AC			
	DC power supply	20.4 to 26.4 V DC			
Power consumption	AC power supply	30 V AC max.		60 V AC max.	
	DC power supply	(See below.)			
Inrush current		30 A max.		60 A max.	
External power supply ( AC only)	Power supply voltage	24 V DC			
	Power supply output ca- pacity	200 mA		300 mA	
Insulation resistance		20 MΩ min. at 500 V DC between the AC terminals and the protective earth terminal.			
Dielectric strength		2,300 V AC at 50/60 Hz for one minute with a leakage current of 10 mA max. between all the external AC terminals and the protective earth terminal.			
Noise resistance		Conforms to IEC61000-4-4, 2 kV (power lines)			
Vibration resistance		10 to 57 Hz with an amplitude of 0.075 mm, and 57 to 150 Hz with an acceleration of 9.8 m/s <sup>2</sup> in the X, Y, and Z directions for 80 minutes each (i.e. swept for 8 minutes, 10 times).			
Shock resistance		147 m/s <sup>2</sup> in the X, Y and Z directions 3 times each.			
Ambient temperature (operating)		0° to 55° C			
Ambient humidity (operating)		10% to 90% (no condensation)			
Ambient environment (operating)		With no corrosive gas			
Ambient temperature (storage)		-20° to 75° C			
Terminal screw size		M3			
Power supply holding time		10 ms min. for AC models, and 2 ms min. for DC models			
Weight		AC model: 400 g max.	AC model: 500 g max.	AC model: 600 g max.	AC model: 700 g max.
		DC model: 300 g max.	DC model: 400 g max.	DC model: 500 g max.	DC model: 600 g max.

**Note:** The specifications of the Expansion I/O Unit are the same as for the CPU except that the power is supplied from the CPU and the weight is 300 g.

**Performance Specifications**

Item		10-point I/O	20-point I/O	30-point I/O	40-point I/O
Control method		Stored program method			
I/O control method		Combination of the cyclic scan and immediate refresh processing methods.			
Programming language		Ladder diagram			
Instruction word		1 step per instruction, 1 to 5 words per instruction			
Types of instructions	Basic instructions	14 types			
	Special instructions	79 types, 139 instructions			
Instruction execution time	Basic instructions	0.72 to 16.2 μs			
	Special instructions	MOV instruction = 16.3 μs			
Program capacity		2,048 words			
Maximum I/O points	CPU only	10 points (6 input/4 output points)	20 points (12 input/8 output points)	30 points (18 input/12 output points)	40 points (24 input/16 output points)
	With Expansion I/O Unit	---	---	90 points (54 input/36 output points)	100 points (60 input/40 output points)
Input bits		00000 to 00915 (Words 0 to 9)			
Output bits		01000 to 01915 (Words 10 to 19)			
Work bits (IR Area)		512: IR 20000 to IR 23115 (IR 200 to IR 231)			
System bits (SR Area)		384: SR 23200 to SR 25515 (SR 232 to SR 255)			
Temporary bits (TR Area)		8: TR 0 to TR 7			
Holding bits (HR Area)		320: HR 0000 to HR 1915 (HR 00 to HR 19)			
Auxiliary bits (AR Area)		256: AR 0000 to AR 1515 (AR 00 to AR 15)			
Link bits (LR Area)		256: LR 0000 to LR 1515 (LR 00 to LR 15)			
Timers/Counters		128:TIM/CNT 000 to 127 100-ms timer: TIM 000 to TIM 127 10-ms timer: TIM 000 to TIM 127 Decremental counter, reversible counter			
Data memory	Read/Write	1,024 words (DM 0000 to DM 1023)			
	Read only	512 words (DM 6144 to DM 6655)			
Interrupt processing: External interrupt		2 points (Response time of 0.3 ms max.)	4 points (Response time of 0.3 ms max.)		
Memory protection		Maintains the contents of the HR, AR, Counter and Data Memory Areas.			
Memory backup		Flash memory:User program, data memory (Read only) (Non-battery powered storage) Super capacitor:Data memory (Read/Write), holding bits, auxiliary memory bits, counter (20-day storage at an ambient temperature of 25° C)			
Self-diagnostic function		CPU error (watchdog timer), memory errors, I/O bus errors			
Program check		No END instruction, programming errors (constantly checked during operation)			
Pulse output		1 point: 2 kHz			
High-speed counter		1 point:Single phase at 5 kHz or two-phase at 2.5 kHz (linear counting method) Incremental mode: 0 to 65535 (16-bit) Decremental mode:-32767 to 32767 (16-bit) 1 point:Single phase at 5 kHz or two-phase at 2.5 kHz (linear counting method) Incremental mode: 0 to 65535 (16-bit) Decremental mode:-32767 to 32767 (16-bit)			
Quick-response inputs		Together with the external interrupt input (minimum pulse width of 0.2 ms)			
Input time constant		Can be set at 1 ms, 2 ms, 4 ms, 8 ms, 16 ms, 32 ms, 64 ms, or 128 ms.			
Analog settings		2 points: (0 to 200)			

**Note:** Bits that are not used for the I/O bits can be used as work bits.

## I/O Specifications

### Input Circuit

#### CPU

Item	Specifications	Circuit
Input voltage	24 V DC +10%/–15%	<p><b>Note:</b> The polarity of the input power supply can be either positive or negative. Resistance values in parentheses are for inputs IN00000 to IN00002.</p>
Input impedance	IN00000 to IN00002: 2 kΩ Others: 4.7 kΩ	
Input current (typical)	IN00000 to IN00002: 12 mA Others: 5 mA	
ON voltage	14.4 V DC min.	
OFF voltage	5.0 V DC max.	
ON delay (see note 1)	1 to 128 ms max. (default: 8 ms) (see note 1)	
OFF delay (see note 1)	1 to 128 ms max. (default: 8 ms) (see note 1)	

- Note:** 1. The actual ON/OFF delay includes a digital filter with a time constant of 1, 2, 4, 8, 16, 32, 64, or 128 ms (default: 8 ms).  
2. The delays for IN00000 to IN00002 are as follows when used for the high-speed counter.

Input	Increment mode	Differential phase mode
IN00000 (A-phase)	5 kHz	2.5 kHz
IN00001 (B-phase)	Normal input	
IN00002 (Z-phase)	ON: 100 μs max. OFF: 500 μs max.	

3. The delays for IN00003 to IN00006 are as follows when used for the high-speed counter.

Delay	0.3 ms max. (From the time of input ON until the interrupt subroutine is executed.) <sup>*1</sup>

<sup>\*1</sup> For detailed specifications of expansion I/O units, see page 68.

### Expansion I/O Unit

Item	Specifications	Circuit
Input voltage	24 V DC +10%/–15%	<p><b>Note:</b> The polarity of the input power supply can be either positive or negative.</p>
Input impedance	4.7 kΩ	
Input current (typical)	5 mA	
ON voltage	14.4 V DC min.	
OFF voltage	5.0 V DC max.	
ON delay (see note 1)	1 to 128 ms max. (default: 8 ms) (see note 1)	
OFF delay (see note 1)	1 to 128 ms max. (default: 8 ms) (see note 1)	

- Note:** The actual ON/OFF delay includes an input constant of 1, 2, 4, 8, 16, 32, 64, or 128 ms (default: 8 ms).

### Output Circuit

#### CPU and Expansion I/O Unit Relay Output

Item	Specifications	Circuit		
Maximum switching capacity	250 V AC/2 A (cosφ =1) 24 V DC/2 A (4 A/common)	<p>Maximum 250 VAC: 2 A 24 VDC: 2A</p>		
Minimum switching capacity	5 V DC, 10 mA			
Relay service life	Electrical		Resistive load	150,000 times (at 24 V DC)
			Inductive load	100,000 times (at 200 V AC, cosφ =0.4)
	Mechanical		20 million times	
ON delay	15 ms max.			
OFF delay	15 ms max.			

### Transistor Output (Sink Type/Source Type) (CPU/Expansion I/O Unit)

Item	Specifications	Circuit
Maximum switching capacity	24 V DC +10%/–15%, 300 mA (see note 1)	
Leakage current	0.1 mA max.	
Residual voltage	1.5 V max.	
ON delay	0.1 ms max.	
OFF delay	1 ms max. (see note 2)	

**Note: 1.** The maximum switching capacity of the CPM1A with transistor outputs (sink type and source type) is limited to the currents shown in the following table for the common and for the Unit.

Item	10CDT-V1/ 10CDT1-A-V1/D-V1	20CDT-D-V1/ 20CDT1-A-V1/D-V1	30CDT-D-V1/ 30CDT1-A-V1/D-V1	40CDT-D-V1/ 40CDT1-A-V1/D-V1	20EDT/20EDT1	CPM1A-8ET/8ET1
Max. switching capacity	0.9 A/Unit	0.9 A/common 1.8 A/Unit	0.9 A/common 2.7 A/Unit	0.9 A/common 3.6 A/Unit	0.9 A/common 1.8 A/Unit	

**2.** When using the pulse output function of the CPM1A with transistor outputs (sink type and source type):  
The output current must be between 100 to 200 mA when using the output 01000 or 01001 as a pulse output with the maximum frequency of 2 kHz.  
The off-delay of outputs 01000 and 01001 will vary depending on the output current.

Load current	OFF delay
100 to 200 mA	0.2 ms max.
0 to 300 mA except for the above range	0.5 ms max.

### Analog I/O Unit

Item	CPM1A-MAD01		CPM1A-MAD11		CPM1A-AD041		CPM1A-DA041		
	Voltage I/O	Current I/O	Voltage I/O	Current I/O	Voltage I/O	Current I/O	Voltage I/O	Current I/O	
Analog inputs	Number of inputs	2		2 (allocated 2 words)		4 (allocated 4 words in + 2 words out)			
	Input signal ranges	0 to 10 V or 1 to 5 V	4 to 20 mA	0 to 5 V, 1 to 5 V, 0 to 10 V, –10 to 10 V	0 to 20 mA, 4 to 20 mA	0 to 5 V, 1 to 5 V, 0 to 10 V, –10 to 10 V	0 to 20 mA, 4 to 20 mA		
	Maximum rated input	±15 V	±30 mA	±15 V	±30 mA	±15 V	±30 mA		
	External input impedance	1 MΩ min.	250 Ω rated	1 MΩ min.	250 Ω	1 MΩ min.	250 Ω		
	Resolution	1/256		1/6,000 (full scale)		1/6,000 (full scale)			
	Overall precision	1.0% of full scale		25°C:±0.3% of full scale 0 to 55°C:±0.6% of full scale	25°C:±0.4% of full scale 0 to 55°C:±0.8% of full scale	25°C:±0.3% of full scale 0 to 55°C:±0.6% of full scale	25°C:±0.4% of full scale 0 to 55°C:±0.8% of full scale		
	Converted A/D data	8-bit binary data Full scale = 0000 to 00FF Hex		Binary data (4-digit hexadecimal) –10 to 10 V: F448 to 0BB8 Hex full scale Other:0000 to 1770 Hex full scale		Binary data (4-digit hexadecimal) –10 to 10 V: F448 to 0BB8 Hex full scale Other:0000 to 1770 Hex full scale			
	Averaging	---		Supported (set for each input with DIP switch)		Supported (set for each input with DIP switch)			
Disconnection detection	---		Supported		Supported				
Analog output (See note 1.)	Number of outputs	1		1 (1 word allocated )				4 (4 words allocated)	
	Output signal ranges	0 to 10 V or –10 to 10 V	4 to 20 mA	1 to 5 V, 0 to 10 V, –10 to 10 V	0 to 20 mA, 4 to 20 mA			1 to 5 V, 0 to 10 V, –10 to 10 V	0 to 20 mA, 4 to 20 mA
	External output allowed load resistance	2 kΩ min.	350 Ω max.	1 kΩ min.	600 Ω max.			1 kΩ min.	600 Ω max.
	External output impedance	---		0.5 Ω max.	---			0.5 Ω max.	---
	Resolution	1/256 (1/512 when the output signal range is –10 to 10 V.)		1/6,000 (full scale)				1/6,000 (full scale)	
	Overall precision	1.0% of full scale		25°C:±0.4% of full scale 0 to 55°C:±0.8% of full scale				25°C:±0.4% of full scale 0 to 55°C:±0.8% of full scale	
	D/A data setting	8-bit plus sign binary data –10 to 10 V output range: Full scale = 80FF to 00FF Hex 4 to 20 mA output range: Full scale = 0000 to 00FF Hex		Binary data (hexadecimal, 4-digit) –10 to 10 V output range: Full scale = F448 to 0BB8 Hex Other output ranges: Full scale = 0000 to 1770 Hex				Binary data (hexadecimal, 4-digit) –10 to 10 V output range: Full scale = F448 to 0BB8 Hex Other output ranges: Full scale = 0000 to 1770 Hex	
Conversion time	10 ms/Unit max. (See note 2.)		2 ms/point		2 ms/point		2 ms/point		
Isolation method	Photocoupler isolation between I/O terminals and PC (There is no isolation between the analog I/O signals.)		Photocoupler isolation between analog I/O and internal circuits. (Individual analog I/O signals are not isolated.)		Photocoupler isolation between analog I/O and internal circuits. (Individual analog I/O signals are not isolated.)		Photocoupler isolation between analog I/O and internal circuits. (Individual analog I/O signals are not isolated.)		

**Note: 1.** The voltage output and current output can be used at the same time, but the total output current cannot exceed 21 mA.  
**2.** The conversion time is the total time for 2 analog inputs and 1 analog output.

**Temperature Sensor Units**

By mounting a Temperature Sensor Unit (CPM1A-TS001/TS002/TS101/TS102) to the PLC, input can be obtained from a thermocouple or platinum resistance thermometer, and temperature measurements can be converted to binary data (4-digit hexadecimal) and cyclically updated in the input area of the CPU Unit.

**Specifications**

Item	Specifications	
Model	CPM1A-TS001/002	CPM1A-TS101/102
Number of inputs	2 (TS001), 4 (TS002)	2 (TS101), 4 (TS102)
Input types	Thermocouple K, J switchable (Note: Same type for all input points.)	Pt100, JPt100 switchable (Note: Same type for all input points.)
Indication accuracy	The larger of $\pm 0.5\%$ of the indicated value and $\pm 2^{\circ}\text{C} \pm 1$ digit max.	[The larger of $\pm 0.5\%$ of the indicated value and $\pm 1^{\circ}\text{C} \pm 1$ digit max.
Conversion time	250 ms/2 points (TS001, TS101); 250 ms/4 points (TS002, TS102)	
Converted temperature data	Binary (4-digit hexadecimal)	
Isolation method	Photocoupler isolation between the temperature input signals.	

**Note:** The indication accuracy when using a K-type thermocouple for temperatures less than  $-100^{\circ}\text{C}$  is  $\pm 4^{\circ}\text{C} \pm 1$  digit max.

**Input Temperature Ranges for CPM1A-TS001/002**

The rotary switch can be used to make of the following range and input type settings for CPM1A-TS001/002 models.

Input type	Range ( $^{\circ}\text{C}$ )	Range ( $^{\circ}\text{F}$ )
K	-200 to 1300	-300 to 2300
	0.0 to 500.0	0.0 to 900.0
J	-100 to 850	-100 to 1500
	0.0 to 400.0	0.0 to 750.0

**Input Temperature Ranges for CPM1A-TS101/102**

The rotary switch can be used to make of the following range and input type settings for CPM1A-TS101/102 models.

Input type	Range ( $^{\circ}\text{C}$ )	Range ( $^{\circ}\text{F}$ )
Pt100	-200.0 to 650.0	-300 to 1200.0
JPt100	-200.0 to 650.0	-300 to 1200.0

**Specifications CPM1A-TS101-DA**

Item	Specifications
Model	CPM1A-TS101-DA
Number of inputs	2
Input types	Pt100
Temperature range	-40 to $250^{\circ}\text{C}$
Converted temperature data	16-bit, 2's complement, $0.1^{\circ}\text{C}$ resolution
Indication accuracy	1.0% of full scale max.
Number of outputs	1
Output type	0 to 10 V, -10 to 10 V, 4 to 20 mA
Load resistance	2 k $\Omega$ min. (voltage output), 500 $\Omega$ max. (current output)
Output resolution	8 bit + sign (1/256, 1/512 for -10 to 10 V)
Output accuracy	1.0% of full scale max.
Conversion time	60 ms (all channels)
Isolation method	Photocoupler isolation between I/O signals and PLC

**DeviceNet I/O Link Unit - CPM1A-DRT21**

By connecting the DeviceNet I/O Link Unit (CPM1A-DRT21), the CPM1A can function as the slave of a DeviceNet Master Unit. In this configuration, 32 input- and 32 output bits are exchanged with the Master Unit.

**Specifications**

Item	Specification
Master/slave	DeviceNet Slave
Number of I/O points allocated to Master	Input: 32 points / Output: 32 points
Number of words allocated from CPM1A's I/O memory	Input: 2 words / Output: 2 words (Allocated in the same way as other Expansion Units).
Node address setting method	Set using DIP switch.

**PROFIBUS-DP I/O Link Unit - CPM1A-PRT21**

By connecting the PROFIBUS-DP I/O Link Unit (CPM1A-PRT21), the CPM1A can function as the slave of any PROFIBUS-DP Master Unit. In this configuration, 16 input- and 16 output bits are exchanged with the Master unit.

**Specifications**

Item	Specification
Master/slave	PROFIBUS-DP slave (OC_0658.GSD)
Number of I/O points allocated to Master	Input: 16 points / Output: 16 points (Intel/Motorola format selectable by DIP switch)
Number of words allocated from CPM1A's I/O memory	Input: 1 word / Output: 1 word (Allocated in the same way as other Expansion Units).
Node address setting method	0-99 using 2 rotary switches

CompoBus/S I/O Link Unit - CPM1A-SRT21

Specifications

Item	Specification
Master/Slave	CompoBus/S Slave
Number of I/O bits	8 input bits, 8 output bits
Number of words occupied in CPM2A I/O memory	1 input word, 1 output word (Allocated in the same way as other Expansion Units).
Node number setting	Set using the DIP switch. (Set before turning ON power for the CPU Unit.)

Communications Adapter Specifications CPM1-CIF01/CIF11

RS-232C Adapter and RS-422 Adapter

Item	Specifications	
	CPM1-CIF01	CPM1-CIF11
Functions	Level conversion between the CMOS level (CPU side) and the RS-232C level (peripheral device side)	Level conversion between the CMOS level (CPU side) and the RS-422 level (peripheral device side)
Isolation (all in this line)	The RS-232C (peripheral device side) is insulated by a DC/DC converter and photocoupler.	The RS-422 (peripheral device side) is insulated by a DC/DC converter and photocoupler.
Power supply	Power is supplied by the CPU.	
Weight	200 g max.	

Expansion Memory Unit CPM1A-EMU01-V1

The CPM1A-EMU01-V1 offers simple onsite transfer of user programs and data memory.

Item	Specifications
Supported PLCs	CPM1, CPM1A, CPM2A, CPM2C, SRM1(-V2), CQM1, CQM1H
Read/write memory areas	User Program: 15.2 kWords max. Data memory: DM 6144 to DM 6655
Expansion instructions	18 instructions
EEPROM	256-Kbit EEPROM, ATMEL: AT28C256, OMRON: EEROM-JD
Current consumption	130 mA max.
Dimensions (not including cables or connectors)	57 x 92 x 38 mm (W x H x D)
Weight	200 g max. (not including EEPROM)

Specifications

CPM2C-PA201 AC Power Supply Unit

- The CPM2C-PA201 is a slim and compact AC Power Supply Unit of the same shape as the CPM2C's CPU Unit. It can be connected simply using the connecting cable (23 cm) provided. It can also be used for CPM1A and CPM2A CPU Units and as display power supply (wired by the user).

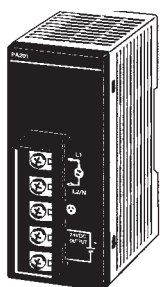

Service power supply for external devices such as sensors (24 V).

AC Power Supply Unit

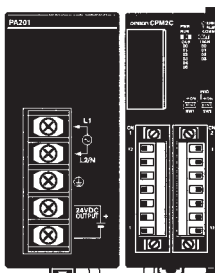

AC Power Supply Unit

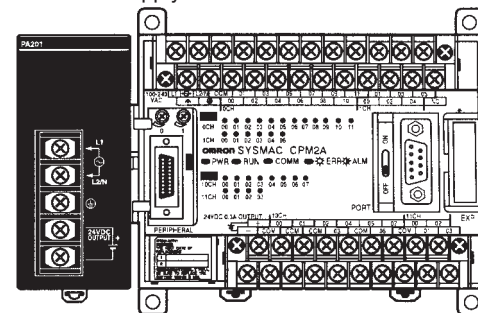

Attached connecting cable

Item	Specification		
Rated output	15 W		
Output voltage	24 V		
Output current	600 mA		
Efficiency	75% min. (at rated output)		
Input conditions	Rated voltage	100 to 240 V AC	
	Allowable voltage range	85 to 264 V AC	
	Frequency	47 to 63 Hz	
	Current	100 V	0.4 A
		200 V	0.2 A
	Leakage current	100 V	0.5 mA max. (at rated output)
		200 V	1 mA max. (at rated output)
	Inrush current	100 V	15 A max. (at 25° C cold start)
200 V		30 A max. (at 25° C cold start)	

Item	Specification	
Output characteristics	Output voltage accuracy	10%~15% (including input, load, and temperature fluctuations)
	Minimum output current	30 mA
	Ripple noise voltage	2% (p-p) max.
	Input fluctuation	0.75% max.
	Load fluctuation	4% max.
	Temperature fluctuation	0.05%/°C max.
	Startup time	300 ms max. (at input voltage of 100 V AC or 200 V AC and the rated output)
	Output hold time	10 ms (at input voltage of 100 V AC or 200 V AC and the rated output)
Overcurrent protection	Self-resetting, operates at 105% to 335% of the rated current, suspended and independent operation	
Overvoltage protection	None	
Ambient operating temperature	0° to 55° C	
Ambient storage temperature	-20° to 75° C (no condensation or icing)	
Ambient operating humidity	10% to 90% (no condensation)	
Dielectric strength	2,000 V for 1 min between all inputs and GR Leakage current: 10 mA 3,000 V for 1 min between all inputs and all outputs Leakage current: 10 mA 1,000 V for 1 min between all outputs and GR Leakage current: 10 mA	
Insulation resistance	100 MΩ min. at 500 V DC between all outputs and any input, and between all outputs and GR	
Vibration resistance	10 to 57 Hz, amplitude, 57 to 150 Hz, acceleration: 9.8 m/s <sup>2</sup> in X, Y, and Z directions for 80 minutes according (Time coefficient: 8 minutes × coefficient factor 10 = total time 80 min.)	
Shock resistance	147 m/s <sup>2</sup> 3 times each in X, Y, and Z directions	
Noise terminal voltage	FCC class A	
Weight	250 g max.	

Peripheral Devices

CPM1A CPU

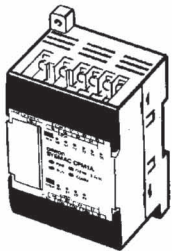

IBM PC/AT or compatible

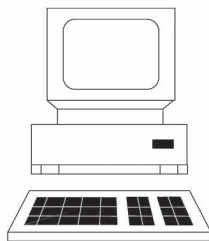

CX-One:  
Omron's integrated software for programming and configuration of all control system components, including PLCs, HMI, drives, temperature controllers and advanced sensors.

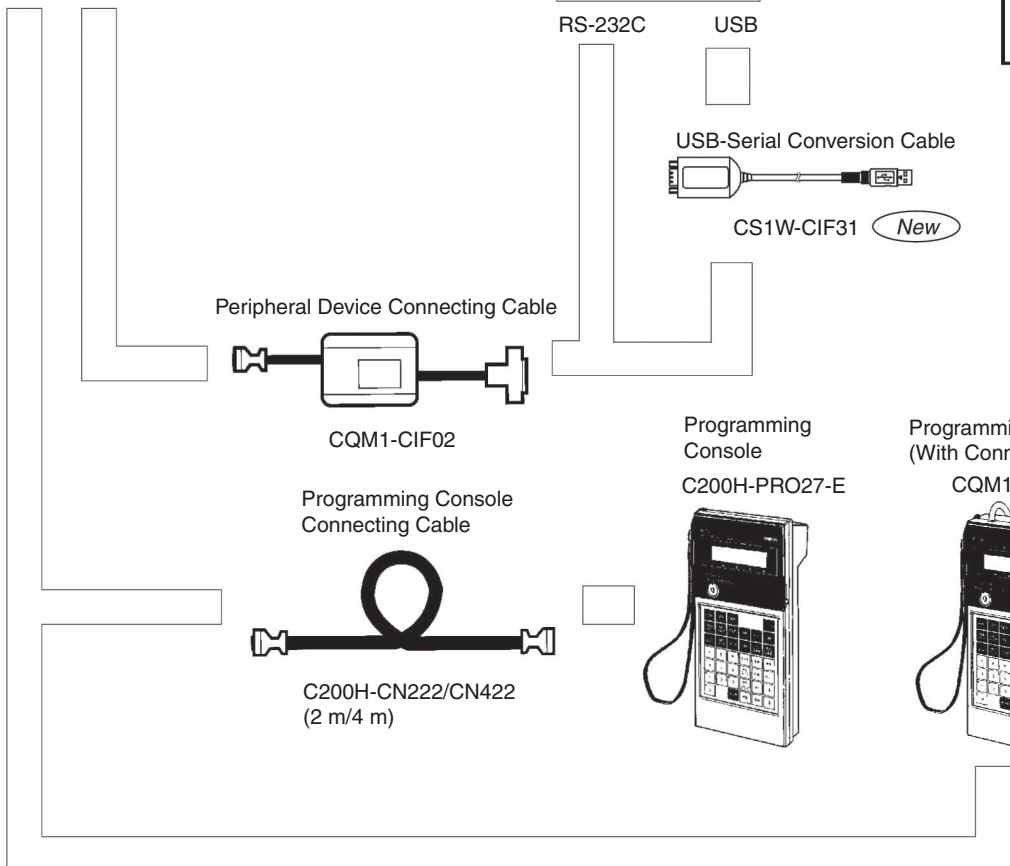
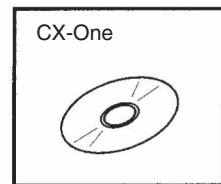

# CPM1A Ordering Information

## International Standards

The products shown in the attached tables are those that conform to the UL, CSA, cULus, cUL, NK, Lloyd's Register, and EC Directives as of September 2003.

(U: UL, C: CSA, UC: cULus, CU: cUL, N: NK, L: Lloyd, CE: EC Directives)

Please contact OMRON representative for application conditions.

## CPU Units

Name	Power supply	Output method	Input points	Output points	Model	Standards
10-point I/O	AC power supply	Relay output	6 points	4 points	CPM1A-10CDR-A-V1	U, C, N, L, CE
		Transistor output (sink type)			CPM1A-10CDT-A-V1	U, C, CE
		Transistor output (source type)			CPM1A-10CDT1-A-V1	
	DC power supply	Relay output			CPM1A-10CDR-D-V1	U, C, N, L, CE
		Transistor output (sink type)			CPM1A-10CDT-D-V1	U, C, CE, N
		Transistor output (source type)			CPM1A-10CDT1-D-V1	
20-point I/O	AC power supply	Relay output	12 points	8 points	CPM1A-20CDR-A-V1	U, C, N, L, CE
		Transistor output (sink type)			CPM1A-20CDT-A-V1	U, C, CE
		Transistor output (source type)			CPM1A-20CDT1-A-V1	
	DC power supply	Relay output			CPM1A-20CDR-D-V1	U, C, N, L, CE
		Transistor output (sink type)			CPM1A-20CDT-D-V1	U, C, CE, N
		Transistor output (source type)			CPM1A-20CDT1-D-V1	
30-point I/O	AC power supply	Relay output	18 points	12 points	CPM1A-30CDR-A-V1	U, C, N, L, CE
		Transistor output (sink type)			CPM1A-30CDT-A-V1	U, C, CE
		Transistor output (source type)			CPM1A-30CDT1-A-V1	
	DC power supply	Relay output			CPM1A-30CDR-D-V1	U, C, N, L, CE
		Transistor output (sink type)			CPM1A-30CDT-D-V1	U, C, CE, N
		Transistor output (source type)			CPM1A-30CDT1-D-V1	
40-point I/O	AC power supply	Relay output	24 points	16 points	CPM1A-40CDR-A-V1	U, C, N, L, CE
		Transistor output (sink type)			CPM1A-40CDT-A-V1	U, C, CE
		Transistor output (source type)			CPM1A-40CDT1-A-V1	
	DC power supply	Relay output			CPM1A-40CDR-D-V1	U, C, N, L, CE
		Transistor output (sink type)			CPM1A-40CDT-D-V1	U, C, CE, N
		Transistor output (source type)			CPM1A-40CDT1-D-V1	

## Expansion Units and Expansion I/O Units

Unit	Input/Output type	Inputs	Outputs	Model	Standards
Expansion I/O Units	Relay	24	16	CPM1A-40EDR	CE, N
	Transistor (sinking)			CPM1A-40EDT	CE, N
	Transistor (sourcing)			CPM1A-40EDT1	CE, N
	Relay	12	8	CPM1A-20EDR1	U, C, CE, N
	Transistor (sinking)			CPM1A-20EDT	U, C, CE, N
	Transistor (sourcing)			CPM1A-20EDT1	U, C, CE, N
	---	8	---	CPM1A-8ED	U, C, CE, N
	Relay	---	8	CPM1A-8ER	U, C, CE, N
	Transistor (sinking)			CPM1A-8ET	U, C, CE, N
	Transistor (sourcing)			CPM1A-8ET1	U, C, L, CE, N
Analog I/O Unit	Analog (resolution: 1/256)	2	1	CPM1A-MAD01	U, C, CE, N
	Analog (resolution: 1/6000)	2	1	CPM1A-MAD11	U, C, CE, N
	Analog (resolution: 1/6000)	4	---	CPM1A-AD041	U, C, CE
	Analog (resolution: 1/6000)	---	4	CPM1A-DA041	U, C, CE
DeviceNet I/O Link Unit	---	I/O Link of 32 input bits and 32 output bits		CPM1A-DRT21	U, C, CE, N
PROFIBUS-DP I/O Link Unit	---	I/O Link of 16 input bits and 16 output bits		CPM1A-PRT21	CE
CompoBus/S I/O Link Unit	---	I/O Link of 8 input bits and 8 output bits		CPM1A-SRT21	U, C, CE, N
Temperature Sensor Units	2 thermocouple inputs			CPM1A-TS001	U, C, CE, N
	4 thermocouple inputs			CPM1A-TS002	U, C, CE, N
	2 platinum resistance thermometer inputs			CPM1A-TS101	U, C, CE, N
	4 platinum resistance thermometer inputs			CPM1A-TS102	U, C, CE, N
	2 Platinum resistance thermometer inputs (-40 to 250 °C) and one output (-10 to 10V, 4 to 20 mA)			CPM1A-TS101-DA	U, C, L, CE

## RS-232C Adapter, RS-422 Adapter, Connecting Cable, Link Adapter

Name	Function	Model	Standards
RS-232C Adapter	Converts peripheral port levels.	CPM1-CIF01	N, L, CE
RS-422 Adapter		CPM1-CIF11	
Connecting Cable	3.3-m cable used to connect IBM PC/AT or compatible personal computers.	CQM1-CIF02	U, C, N, L, CE
Link Adapter	Converts RS-232C and RS-422 levels.	3G2A9-AL004-E	---

## Programming Consoles and Cables

Product	Model	Standards	
Programming Console (2-m cable attached)	CQM1-PRO01-E	U, C, N, CE	
Programming Console (Requires separate cable. See below.)	C200H-PRO27-E	U, C, N, CE	
Connecting Cable for C200H-PRO27-E	2-m cable	C200H-CN222	N
	4-m cable	C200H-CN422	---

## Support Software

Product	Functions	Model	Standards
CX-One	Omron's integrated software for programming and configuration of all control system components, including PLCs, HMI, drives, temperature controllers and advanced sensors.	CX-ONE-AL□□C-E <sup>*1</sup>	---

\*1 □□ = Number of licenses (01, 03, 10)

Product	Model	Standards
Expansion Memory Unit	CPM1-EMU01-V1	---
EEPROM (256 K)	EEEROM-JD	---

## Power Supply Unit

Unit	Input	Output	Model	Standards
Power Supply	100 to 240 V AC	24 V DC/600 mA	CPM2C-PA201	U, C, CE

Compact PLC series

# CPM2A/CPM2B/CPM2C

**Advanced functions and high performance in a compact shape. Ideal for automation of packaging and conveyor systems. Provides increased performance and added value to any compact machine.**

**High Performance**

**Versatile Functions for More Advanced Systems**

- High-speed counter inputs for position sensing or object counting.
- Synchronous control simplifies timing adjustment.
- High-speed processing with an interrupt function for immediate response.
- Supports both stand-alone and distributed control.

**Efficient and effective**

**Highly Economical**

The combination of advanced functions and high performance in an economical PLC range will add value to your machines.

**Compact**

**Fits into your available space**

A choice of three different compact form factors means you can more easily fit the functions you need in the space you have available in your control cabinet or machine.

**Compact block-type PLCs**

**SYSMAC CPM2A**

**AC Power Supply**

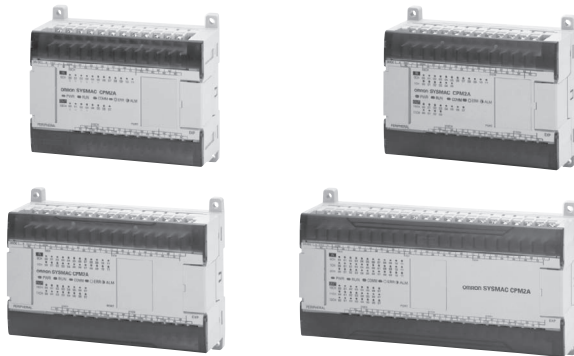

**DC Power Supply**

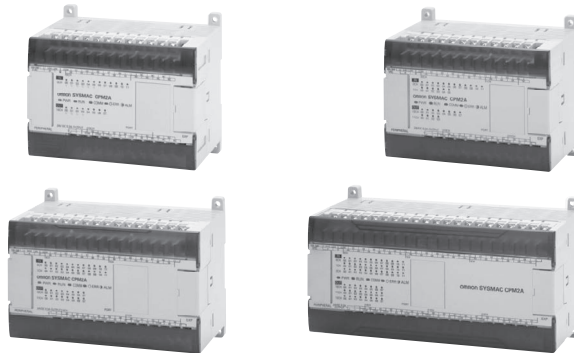

**Modular Board PLCs**

**SYSMAC CPM2B**

Proven CPM2 technology to fit in the tightest spaces. And if the standard models do not fit, we'll make the exact shape and I/O combination you need.

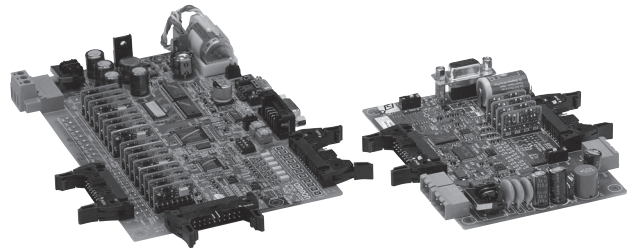

**Compact slim-line PLCs**

**SYSMAC CPM2C**

**10 I/O Points**



**20 I/O Points**



**32 I/O Points**



**Power Supply**



**Communication Adapter**



**Expansion I/O: Digital, Analog**



**Temperature Sensor**



**A full line-up to fit your needs**

A wide range of models is available to achieve the machine or line controller that you require. Select from 16 CPU types, for AC power, DC power, relay output, transistor output, etc. Match the power supply, output, number of I/O points, and size to your particular needs. Expansion I/O Units can also be easily added to increase I/O points.

**Removable Terminal Blocks for Easy Maintenance**

Removable terminal blocks\* simplify installation, troubleshooting and machine maintenance.  
(\*CPU Unit only)

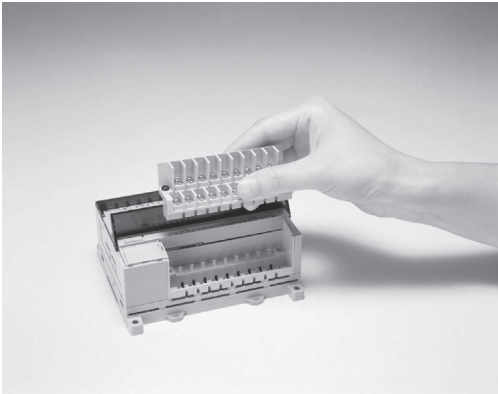

**Expandable up to 140 I/O Points**

Even with its ultracompact size, the CPM2C features a wide range of models for efficient machine control. Ten CPU types, all with DC power supply, allow selection of relay output or transistor output, terminal block or connector wiring, clock function, and other functions. Choose the output type, number of I/O points and other features to meet your needs. Expansion I/O Units (8, 10, 16, or 24 I/O points) are also available to provide control for a maximum of 140 I/O points.

**Easy-to-Read LED Display**

The LED display on the upper part of the CPM2C is easy to read, even when cables are connected.

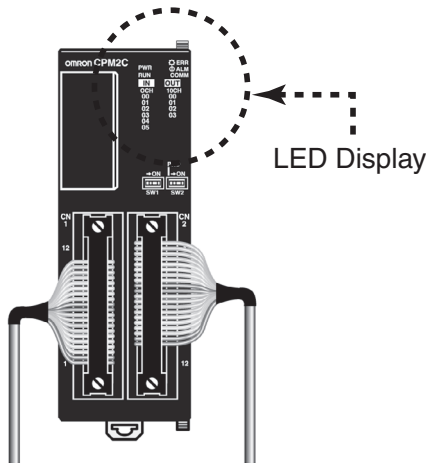

**Built-in RS-232C Port**

The built-in RS-232C port enables connection with a variety of equipment. The communication port can be used for configuration, maintenance, troubleshooting, visualisation or general-purpose serial communication.

**PT Connection**

Compatible with the OMRON Programmable Terminal's Programming Console functions. Maintenance is simplified with the on-screen programming operations.

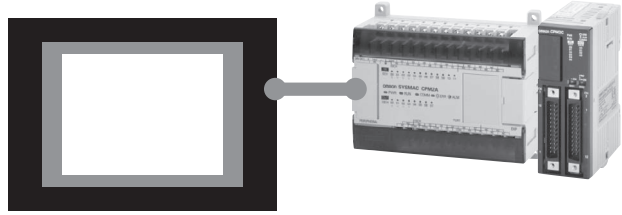

**Host Link**

Host Link allows reading and writing of the I/O memory and operation modes of the CPM2A or CPM2C by a personal computer. The following RS422/RS-232C Communications Adapters also provide 1:n communications.

- CPM2A: CPM1-CIF11
- CPM2C: CPM2C-CIF11

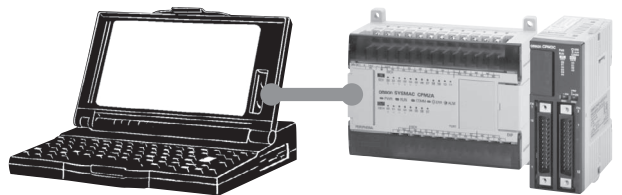

**One-to-one Link**

A 1:1 PLC Link connection can be established with another CPM2C, or a CQM1(H), CPM1, CPM1A, CPM2A, SRM1(-V2), C200HS, or C200HX/HG/HE PLC.

**Windows-based Programming Support**

The Windows-based CX-One Support Software is available for programming all OMRON PLC's, including the CPM2A or CPM2C. Being able to program in the Windows environment reduces programming steps, and gives you access to a large number of display monitor and debugging functions. It also means that you can use existing Windows applications to help with CPM2A or CPM2C programming, which adds up to a highly advanced programming environment.

# CPM2-series Features

The illustrations in this section show CPM2A PLCs, but the same functions are available in CPM2B/CPM2C PLCs unless otherwise stated.

**Interrupts**

The CPM2-series PLCs provide the following kinds of interrupt processing.

**Interrupt Inputs**

Interrupt programs are executed when inputs to the CPU Unit's built-in input points (00003 to 00006) are turned from OFF to ON. Interrupt subroutine numbers 000 to 003 are allocated to input points 00003 to 00006.

**Interval Timer Interrupts**

Interval timer interrupt programs are executed with a precision of 0.1 ms. Interrupt subroutine numbers 000 to 049 are allocated by instructions.

**Count-up Interrupts**

Input signals to the CPU Unit's built-in input points (00003 to 00006) are counted at high speed (up to 2 kHz), and the normal program is stopped and an interrupt program is executed when the count reaches the SV. Interrupt subroutine numbers 000 to 003 are allocated to input points 00003 to 00006.

**Count-check Interrupts Using the High-speed Counter**

Pulse inputs to the CPU Unit's built-in input points (00000 to 00002) are counted at high speed (up to 20 kHz or 5 kHz), and an interrupt program is executed when the present value matches the target value or falls within a given range. Interrupt subroutine numbers 000 to 049 are allocated by instructions.

**Interval Timer Interrupts**

The CPM2 has one interval timer (precision: 0.1 ms) that can be set from 0.5 ms to 319,968 ms. There are two interrupt modes: the single-interrupt mode, in which a single interrupt is executed when the time is up, and the scheduled-interrupt mode, in which interrupts are executed at regular intervals.

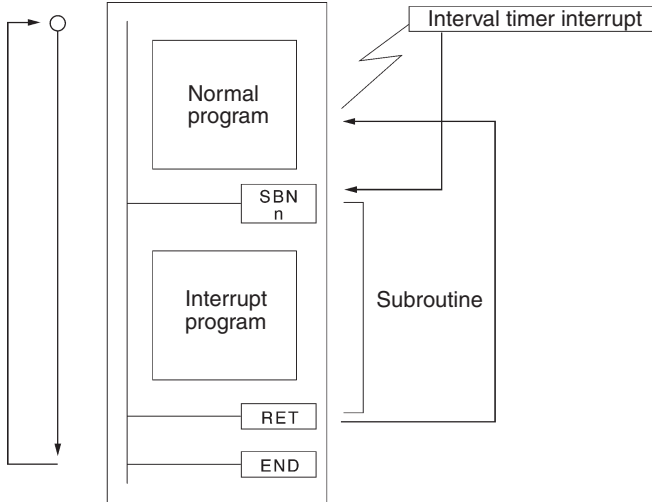

Item	Single-interrupt mode	Scheduled-interrupt mode
Operation	Interrupt is executed once when time has elapsed.	Interrupts are executed at regular intervals.
Set time	0.5 to 319,968 ms (Unit: 0.1 ms)	
Interrupt response time	0.3 ms (from when time has elapsed until execution of interrupt program)	

**High-speed Counters**

The CPM2 CPU Unit has a built-in high-speed counter that can count input pulses at up to 20 kHz. When combined with the interrupt function, the high-speed counter can be used for target-value comparison or range comparison control that is unaffected by the cycle time.

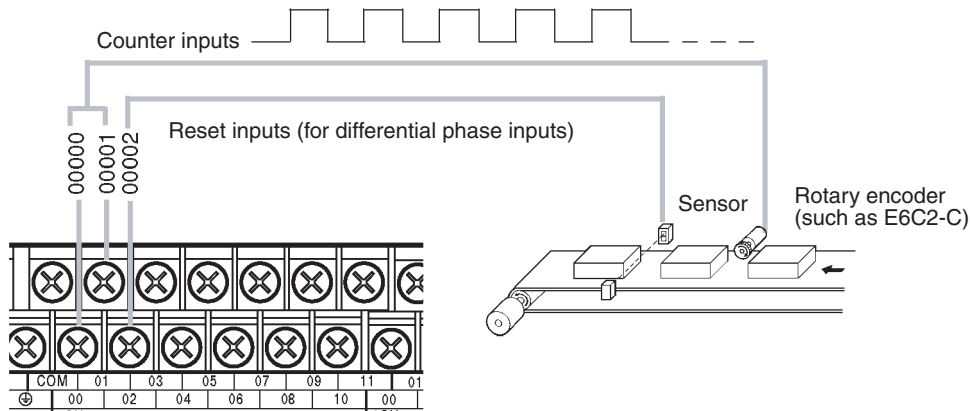

Input	Response frequency	Input mode (count value)	Counter PV Storage	Control method
00000	5 kHz	Differential phase input mode (-8,388,608 to 8,388,607)	SR 248 and SR 249	Target value comparison interrupts Range comparison interrupts
00001	20 kHz	Pulse + direction input mode (-8,388,608 to 8,388,607)		
00002		Up/down pulse input mode (-8,388,608 to 8,388,607) Increment mode (0 to 16,777,215)		

**Interrupt Inputs (Counter Mode)**

The four built-in interrupt inputs in the CPM2 CPU Unit can be used in counter mode to count inputs of up to 2 kHz. These inputs can be used as either incrementing counters or decrementing counters and can trigger an interrupt (i.e., execute an interrupt subroutine) when the count matches the set value.

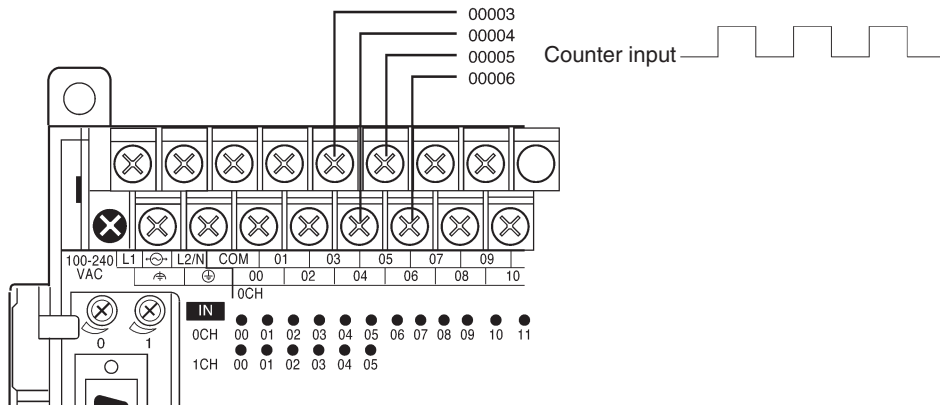

Input	Counter number	Set value location	Present value location	Response frequency	Input mode (count value)	Control method
00003	Counter 0	SR 240	SR 244	2 kHz	Incrementing counter (0000 to FFFF) Decrementing counter (0000 to FFFF)	Count-up interrupts
00004	Counter 1	SR 241	SR 245			
00005	Counter 2	SR 242	SR 246			
00006	Counter 3	SR 243	SR 247			

### Pulse Outputs

The CPM2 has two pulse outputs. The PLC Setup can be set to use these outputs as two single-phase outputs without acceleration and deceleration, two variable duty-ratio pulse outputs, or pulse outputs with trapezoidal acceleration/deceleration (one pulse + direction output and one up/down pulse output). The pulse output's PV coordinate system can also be specified in the PC Setup as either relative or absolute.

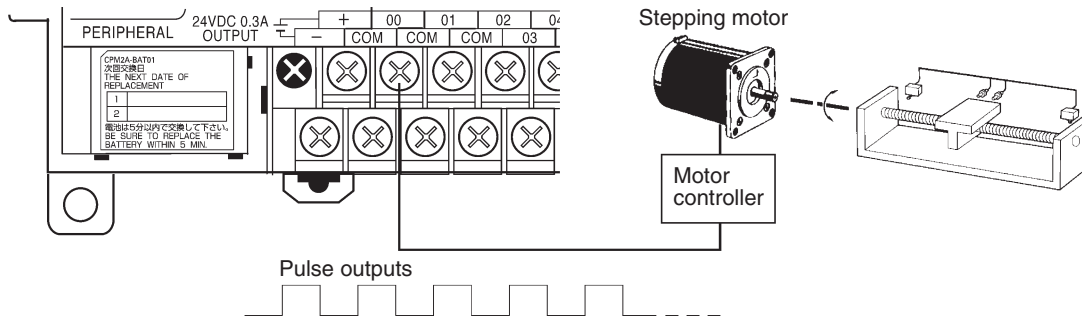

Item	Single-phase pulse output without accel/decel	Variable duty-ratio pulse output	Single-phase pulse output with trapezoidal acceleration/deceleration	
			Pulse + direction output	Up/down pulse output
Controlling instruction(s)	PULS(65) and SPED(64)	PWM(—)	PULS(65) and ACC(—)	
Output number	01000 01001	Pulse output 0 (See note.) Pulse output 1 (See note.)	Pulse output 0 0	Pulse output Direction output
Output frequency range	10 Hz to 10 kHz	0.1 Hz to 999.9 Hz	10 Hz to 10 kHz	
Pitch	10 Hz	0.1 Hz	10 Hz	
Duty ratio	50%	0 to 100%	50%	

Note: With single-phase pulse outputs, pulse outputs 0 and 1 can each be output independently.

### Synchronized Pulse Control

The CPM2's high-speed counter function can be combined with the pulse output function to generate an output pulse at a specified multiple of the input pulse frequency.

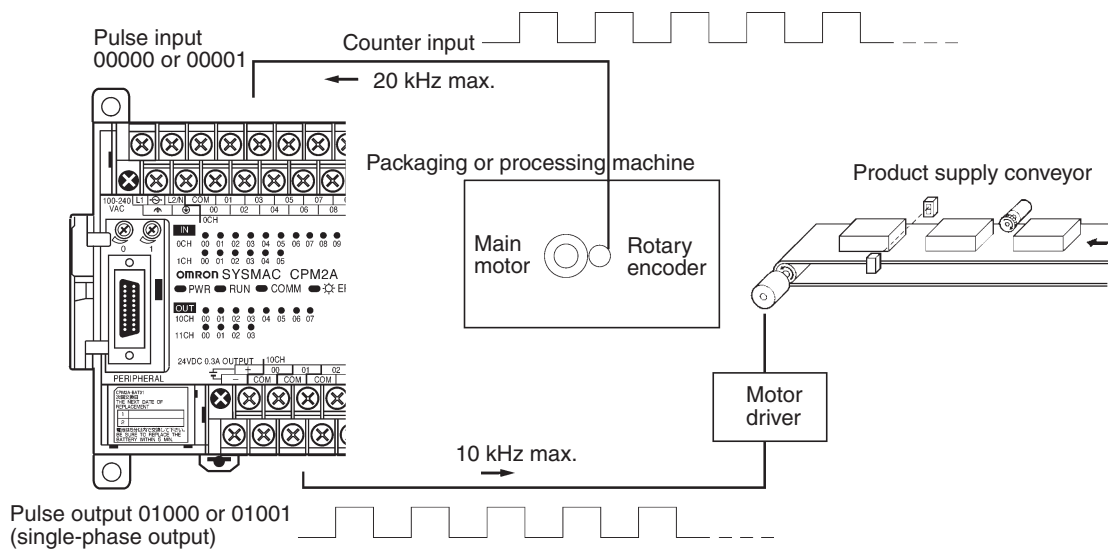

Item	Input mode			
	Phase differential input mode	Pulse + direction input mode	Up/down pulse input mode	Increment mode
Input number	00000 00001	A-phase input Count input	CW input CCW input	Count input See note 1.
Input method	Phase differential quadruple input	Single-phase input	Single-phase input	Single-phase input
Input frequency range	10 Hz to 500 Hz (accuracy ±1 Hz) 20 Hz to 1 kHz (accuracy ±1 Hz) 300 Hz to 20 kHz (accuracy ±25 Hz) (See note 2.)			
Output frequency range	10 Hz to 10 kHz (accuracy 10 Hz)			
Frequency ratio (scaling factor)	1 % to 1,000% (Can be specified in units of 1%.)			
Synchronized control cycle	10 ms			

Note: 1. Can be used as an ordinary input.  
2. The accuracy is ±10 Hz when the input frequency is 10 kHz or less.

## Quick-response Inputs

The CPM2A/CPM2B CPU Units and CPM2C CPU Units with 20 I/O points have four inputs that can be used for quick-response inputs. The CPM2C CPU Units with 10 I/O points have two inputs that can be used for quick response inputs. These inputs are shared with interrupt inputs and 2-kHz high-speed counter inputs. Quick-response inputs are received into an internal buffer, so signals that change status within a cycle can be received.

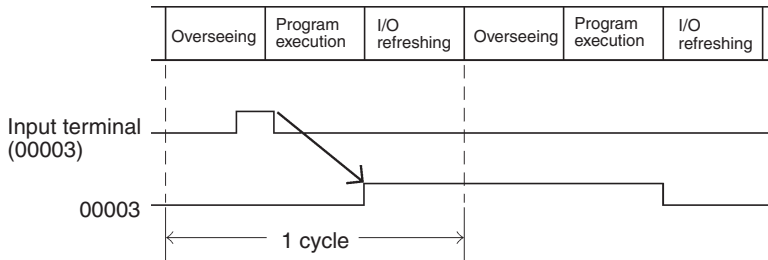

Input number	Min. input signal
00003	50 $\mu$ s
00004	
00005	
00006	

Inputs 00003 through 00006 can be used as interrupt inputs, 2-kHz high-speed counter inputs, or quick-response inputs. These inputs can be used as ordinary inputs if they are not used as interrupt inputs, 2-kHz high-speed counter inputs, or quick-response inputs.

Inputs 00005 and 00006 cannot be used with the CPM2C CPU Unit with 10 I/O points.

## Analog Controls (CPM2A Only)

The CPM2A CPU Unit has two analog controls that can be used for a wide range of timer and counter analog settings. As these controls are turned, values from 0 to 200 (BCD) are stored in the SR Area.

Control	Storage area	Set value (BCD)
Analog control 0	SR 250	0000 to 0200
Analog control 1	SR 251	0000 to 0200

## Clock Function

The CPM2A and some CPM2B/2Cs have a built-in clock (accuracy:  $\pm 1$  minute/month) that allows the date and time to be read from the ladder program. The time can be overwritten from a Programming Console or other Programming Device, but the CPM2A is also equipped with a 30-second Compensation Bit. The time will be rounded off to the nearest minute when this bit is turned ON, so the time can be set very accurately by turning ON this bit when the "time tone" is heard on the radio.

(The CPM2B/CPM2C CPU Units have models with the clock function and models without.)

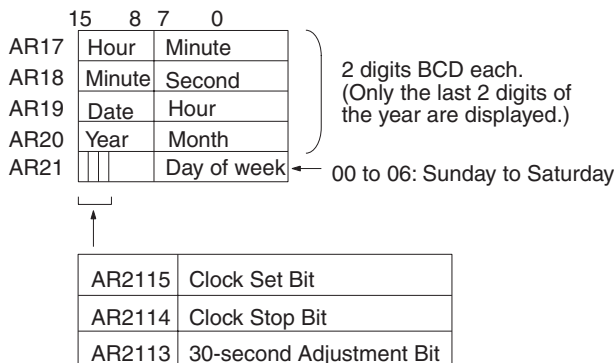

## Additional Timer Functions

VERY HIGH-SPEED TIMER (Units: 1 ms)	Starts a very high-speed decrementing ON-delay timer with the specified timer number. The set value can be 0 to 9,999 ms. (Set in 1-ms units.)
LONG TIMER (Units: 1 s or 10 s)	Starts a long-term decrementing ON-delay timer with the specified timer number. The set value can be 0 to 9,999 s (when set in 1-s units) or 0 to 99,990 s (when set in 10-s units).

## NT Links

The CPM2 can be connected to an OMRON PT (Programmable Terminal) in NT Link mode (1:1). A communications program is not required in the CPM2. The RS-232C port can be used for the NT Link.

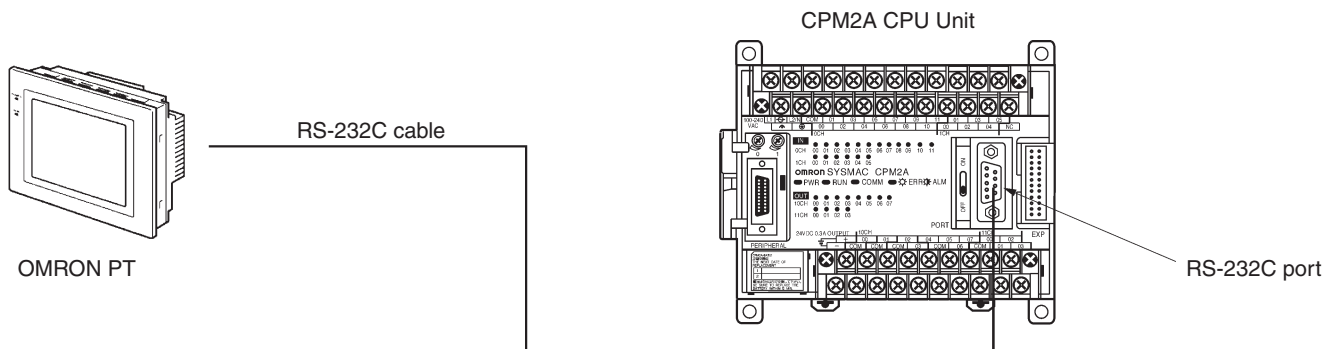

Compact PLC series  
**CPM2A**

An extensive line-up lets you easily configure machines and production lines to meet your needs

**SYSMAC CPM2A**

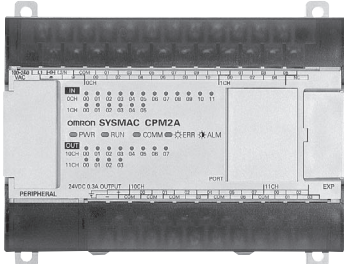

Every CPM2A CPU comes equipped with an RS-232C interface as standard, e.g. to provide easy connection with a Programmable Terminal for fast and easy machine monitoring, temperature setting, etc. Simple positioning with the pulse I/O function is another example of the many advanced functions and high added value that the CPM2A brings to compact machines. Removable terminal blocks ensure easy maintenance, and the CPM2A uses the same Expansion I/O Units as the CPM1A for easy and economical sharing of system components.

**CPU Units with AC Power Supply Depth: 90 mm**

■ Relay Output CPU Unit  
CPM2A-20CDR-A  
● Input points: 12, DC input  
● Output points: 8

■ Relay Output CPU Unit  
CPM2A-40CDR-A  
● Input points: 24, DC input  
● Output points: 16

■ Relay Output CPU Unit  
CPM2A-30CDR-A  
● Input points: 18, DC input  
● Output points: 12

■ Relay Output CPU Unit  
CPM2A-60CDR-A  
● Input points: 36, DC input  
● Output points: 24

**CPU Units with DC Power Supply Depth: 55 mm**

■ Relay Output CPU Unit  
CPM2A-20CDR-D

■ Relay Output CPU Unit  
CPM2A-40CDR-D

■ Transistor Output CPU Units  
CPM2A-20CDT-D (Sink)  
CPM2A-20CDT1-D (Source)  
● Input points: 12, DC input  
● Output points: 8

■ Transistor Output CPU Units  
CPM2A-40CDT-D (Sink)  
CPM2A-40CDT1-D (Source)  
● Input points: 24, DC input  
● Output points: 16

■ Relay Output CPU Unit  
CPM2A-30CDR-D

■ Relay Output CPU Unit  
CPM2A-60CDR-D

■ Transistor Output CPU Units  
CPM2A-30CDT-D (Sink)  
CPM2A-30CDT1-D (Source)  
● Input points: 18, DC input  
● Output points: 12

■ Transistor Output CPU Units  
CPM2A-60CDT-D (Sink)  
CPM2A-60CDT1-D (Source)  
● Input points: 36, DC input  
● Output points: 24

**Expansion I/O Units**

CPM1A-8ED  
● Input points: 8, DC input

CPM1A-8ER  
Output points: 8, RY output

CPM1A-8ET  
● Output points: 8, TR output (Sink)

CPM1A-8ET1  
● Output points: 8, TR output (Source)

CPM1A-20EDR1  
● Input points: 12, DC input  
● Output points: 8, RY output

CPM1A-20EDT  
● Input points: 12, DC input  
● Output points: 8, TR output (Sink)

CPM1A-20EDT1  
● Input points: 12, DC input  
● Output points: 8, TR output (Source)

**Temperature Sensor Units**

CPM1A-TS001  
● Thermocouple inputs: 2

CPM1A-TS002  
● Thermocouple inputs: 4

CPM1A-TS101  
● Pt100 inputs: 2

CPM1A-TS-101-DA  
● Pt100 inputs: 2,  
Analog inputs: 1

CPM1A-TS102  
● Pt100 inputs: 4

**Analog I/O Units**

CPM1A-MAD01  
(Resolution: 256)

CPM1A-MAD11  
(Resolution: 6,000)  
2 inputs + 1 output

CPM1A-AD041 (4 inputs)

CPM1A-DA041 (4 outputs)

**DeviceNet**

CPM1A-DRT21  
● I/O Link inputs: 32  
● I/O Link outputs: 32

**PROFIBUS-DP**

CPM1A-PRT21  
● I/O Link inputs: 16  
● I/O Link outputs: 16

**CompoBus/S**

CompoBus/S  
I/O Unit

CPM1A-SRT21  
● I/O Link inputs: 8  
● I/O Link outputs: 8

**Specifications**

**General**

Item		CPU Units with 20 I/O points	CPU Units with 30 I/O points	CPU Units with 40 I/O points	CPU Units with 60 I/O points
Supply voltage	AC power	100 to 240 V AC, 50/60 Hz			
	DC power	24 V DC			
Operating voltage range	AC power	85 to 264 V AC			
	DC power	20.4 to 26.4 V DC			
Power consumption	AC power	60 VA max.			
	DC power	20 W max. (See separate table following this one for details.)			
Inrush current	AC power	60 A max.			
	DC power	20 A max.			
External power supply (AC power supplies only)	Supply voltage	24 V DC			
	Output capacity	300 mA (See note)			
Insulation resistance	20 MΩ min. (at 500 V DC) between the external AC terminals and protective earth terminals				
Dielectric strength	2,300 V AC 50/60 Hz for 1 min between the external AC and protective earth terminals, leakage current: 10 mA max.				
Noise immunity	Conforms to IEC61000-4-4, 2 kV (power lines)				
Vibration resistance	10 to 57 Hz, 0.075-mm amplitude, 57 to 150 Hz, acceleration: 9.8 m/s <sup>2</sup> in X, Y, and Z directions for 80 minutes each (Time coefficient; 8 minutes × coefficient factor 10 = total time 80 minutes)				
Shock resistance	147 m/s <sup>2</sup> three times each in X, Y, and Z directions				
Ambient temperature	Operating: 0° to 55° C Storage: -20° to 75° C				
Humidity	10% to 90% (with no condensation)				
Atmosphere	Must be free from corrosive gas				
Terminal screw size	M3				
Power interrupt time	AC power supply: 10 ms min. DC power supply: 2 ms min.				
CPU Unit weight	AC power	650 g max.	700 g max.	800 g max.	1,000 g max.
	DC power	550 g max.	600 g max.	700 g max.	900 g max.
Expansion Unit weight	Units with 20 I/O Points: 300 g max. Units with 8 Output Points: 250 g max. Units with 8 Input Points: 200 g max. MAD01 Analog I/O Unit: 150 g max. MAD11 Analog I/O Unit: 250 g max. AD041/DA041 Analog I/O units: 200 g max. Temperature Sensor Units: 250 g max. CompoBus/S I/O Link Units: 200 g max. DeviceNet I/O Link Unit: 200 g max. PROFIBUS-DP I/O Link Unit: 150 g max.				

**Note:** Use the external power supply as the power supply for input devices only. (It cannot be used as to drive output devices.) If the external power supply current exceeds the rated current, or there is a short-circuit, the external power supply voltage will drop and PC operation will stop. If there are 3 CPM1A-MAD11 Units mounted to a CPM2A-60CDR-A, the current for the external power supply must not exceed 200 mA.

**Power Consumption for CPM2A CPU Units with DC Power Supplies**

Use the following information when computing CPM2A power capacities.

CPM2A CPU Unit	Power consumption (W)
CPM2A-20CDR-D	4
CPM2A-30CDR-D	4.5
CPM2A-40CDR-D	6
CPM2A-60CDR-D	7.5
CPM2A-20CDT/T1-D	3.5
CPM2A-30CDT/T1-D	4
CPM2A-40CDT/T1-D	4.5
CPM2A-60CDT/T1-D	5

CPM1A Expansion I/O Unit or Expansion Unit	Power consumption (W)
CPM1A-20EDR1	2.5
CPM1A-20EDT/T1	1.5
CPM1A-8ED	1
CPM1A-8ER	2
CPM1A-8ET/T1	1
CPM1A-DRT21	1
CPM1A-SRT21	1
CPM1A-MAD01/MAD11	3.5
CPM1A-TS001/TS101	3
CPM1A-TS002/TS102	3
CPM1A-PRT21	1
CPM1A-TS101-DA	1.5
CPM1A-AD041	3
CPM1A-DA041	3.3

**Note:** When calculating the total power consumption, it is also necessary to include the power consumption of Programming Consoles, RS-232C Adapter Units, and other devices.

**CPM2A Characteristics**

Item		Specification			
Control method		Stored program method			
I/O control method		Cyclic scan with direct output (Immediate refreshing can be performed with IORF(97).)			
Programming language		Ladder diagram			
Instruction length		1 step per instruction, 1 to 5 words per instruction			
Instructions		Basic instructions: 14 Special instructions: 105 instructions, 185 variations			
Execution time		Basic instructions: 0.64 μs (LD instruction) Special instructions: 7.8 μs (MOV instruction)			
Program capacity		4,096 words			
I/O capacity	CPU Unit only	20 points	30 points	40 points	60 points
	With Expansion I/O Units	80 points max.	90 points max.	100 points max.	120 points max.
Input bits		IR 00000 to IR 00915 (Words not used for input bits can be used for work bits.)			
Output bits		IR 01000 to IR 01915 (Words not used for output bits can be used for work bits.)			
Work bits		928 bits: IR 02000 to IR 04915 (Words IR 020 to IR 049) and IR 20000 to IR 22715 (Words IR 200 to IR 227)			
Special bits (SR area)		448 bits: SR 22800 to SR 25515 (Words IR 228 to IR 255)			
Temporary bits (TR area)		8 bits (TR0 to TR7)			
Holding bits (HR area)		320 bits: HR 0000 to HR 1915 (Words HR 00 to HR 19)			
Auxiliary bits (AR area)		384 bits: AR 0000 to AR 2315 (Words AR 00 to AR 23)			
Link bits (LR area)		256 bits: LR 0000 to LR 1515 (Words LR 00 to LR 15)			
Timers/Counters		256 timers/counters (TIM/CNT 000 to TIM/CNT 255) 1-ms timers: TMHH(—) 10-ms timers: TIMH(15) 100-ms timers: TIM 1-s/10-s timers: TIML(—) Decrementing counters: CNT Reversible counters: CNTR(12)			
Data memory		Read/Write: 2,048 words (DM 0000 to DM 2047)* Read-only: 456 words (DM 6144 to DM 6599) PC Setup: 56 words (DM 6600 to DM 6655) *The Error Log is contained in DM 2000 to DM 2021.			
Basic interrupts	Interrupt processing	External interrupts: 4 (Shared by the external interrupt inputs (counter mode) and the quick-response inputs.)			
	Interval timer interrupts	1 (Scheduled Interrupt Mode or Single Interrupt Mode)			
High-speed counter	High-speed counter	One high-speed counter: 20 kHz single-phase or 5 kHz two-phase (linear count method) Counter interrupt: 1 (set value comparison or set-value range comparison)			
	Interrupt Inputs (counter mode)	Four inputs (Shared with external interrupt inputs (counter mode) and quick-response inputs.) Counter interrupts: 4 (Shared by the external interrupt inputs and quick-response inputs.)			
Pulse output		Two points with no acceleration/deceleration, 10 Hz to 10 kHz each, and no direction control. One point with waveform acceleration/deceleration, 10 Hz to 10 kHz, and direction control. Two points with variable duty-ratio outputs using PWM(—). (Pulse outputs can be used with transistor outputs only, they cannot be used with relay outputs.)			
Synchronized pulse control		One point: A pulse output can be created by combining the high-speed counter with the pulse output and multiplying the frequency of the input pulses from the high-speed counter by a fixed factor. (This output is possible with transistor outputs only, it cannot be used with relay outputs.)			
Quick-response inputs		Four points (Min. input pulse width: 50 μs min.)			
Analog controls		2 controls, setting range: 0 to 200			
Input time constant		Can be set for all input points. (1 ms, 2 ms, 3 ms, 5 ms, 10 ms, 20 ms, 40 ms, or 80 ms; default setting: 10 ms)			
Clock function		Shows the year, month, day of the week, day, hour, minute, and second. (Battery backup)			
Communications functions		Built-in peripheral port: Supports host link, peripheral bus, no-protocol, or Programming Console connections. Built-in RS-232C port: Supports host link, no-protocol, 1:1 Slave Unit link, 1:1 Master Unit link, or 1:1 NT Link connections.			
Functions provided by Expansion Units		Analog I/O Unit: Provides 2 analog inputs and 1 analog output. CompoBus/S I/O Link Unit: Provides 8 inputs and 8 outputs as a CompoBus/S Slave. Temperature Sensor Units: Provide 2 or 4 thermocouple inputs, or 2 or 4 temperature-resistance thermometer inputs.			
Memory protection		HR area, AR area, program contents, read/write DM area contents, and counter values maintained during power interruptions.			
Memory backup		Flash memory: Program, read-only DM area, and PC Setup Battery backup: The read/write DM area, HR area, AR area, and counter values are backed up by a battery. (Battery life is approximately 5 years at an ambient temperature of 25° C.)			
Self-diagnostic functions		CPU Unit failure (watchdog timer), I/O bus error, and memory failure, battery error			
Program checks		No END instruction and programming errors are checked at the start of operation.			

CPM2A I/O Specifications

1. CPU Unit Input Specifications

Item	Inputs	Specification	Circuit configuration
Input voltage	All	24 V DC $+10\%/_{-15\%}$	
Input impedance	IN00000 to IN00001	2.7 kΩ	
	IN00002 to IN00006	3.9 kΩ	
Input current	IN00000 to IN00001	8 mA	
	IN00002 to IN00006	6 mA	
	IN00007 and up	5 mA	
ON voltage/current	IN00000 to IN00001	17 V DC min., 5 mA	
IN00002 and up	14.4 V DC min., 3 mA		
OFF voltage/current	All	5.0 V DC max., 1 mA	
ON delay	All	1 to 80 ms max. Default: 10 ms (See note.)	
OFF delay	All	1 to 80 ms max. Default: 10 ms (See note.)	

**Note:** The input time constant can be set to 1, 2, 3, 5, 10, 20, 40, or 80 ms in the PC Setup.

High-speed Counter Inputs

Inputs IN00000 through IN00002 can be used as high-speed counter inputs, as shown in the following table. The maximum count frequency is 5 kHz in differential phase mode and 20 kHz in the other modes.

Input	Function			
	Differential phase mode	Pulse + direction input mode	Up/down input mode	Increment mode
IN00000	A-phase pulse input	Pulse input	Increment pulse input	Increment pulse input
IN00001	B-phase pulse input	Direction input	Decrement pulse input	Normal input
IN00002	Z-phase pulse input/Hardware reset input (IN00002 can be used as a normal input when it is not used as a high-speed counter input.)			

Interrupt Inputs

Inputs IN00003 through IN00006 can be used as interrupt inputs (interrupt input mode or counter mode) and quick-response inputs. The minimum pulse width for these inputs is 0.05 ms.

2. Expansion I/O Unit Input Specifications

Item	Specification	Circuit configuration
Input voltage	24 V DC $+10\%/_{-15\%}$	
Input impedance	4.7 kΩ	
Input current	5 mA	
ON voltage	14.4 V DC min.	
OFF voltage	5.0 V DC max.	
ON delay	1 to 80 ms max. Default: 10 ms (See note.)	
OFF delay	1 to 80 ms max. Default: 10 ms (See note.)	

**Note:** The input time constant can be set to 1, 2, 3, 5, 10, 20, 40, or 80 ms in the PC Setup.

### 3. CPM2A Output Specifications (CPU Units and Expansion I/O Unit)

#### Relay Output

Item	Specification	Circuit configuration
Max. switching capacity	2 A, 250 V AC ( $\cos\phi = 1$ ) 2 A, 24 V DC (4 A/common)	
Min. switching capacity	10 mA, 5 V DC	
Service life of relay	Electrical: 150,000 operations (24- V DC resistive load) 100,000 operations (240- V AC inductive load, $\cos\phi = 4$ ) Mechanical: 20,000,000 operations	
ON delay	15 ms max.	
OFF delay	15 ms max.	

#### Transistor Output (Sinking)

Item	Specification					
	CPM2A-20CDT-D	CPM2A-30CDT-D	CPM2A-40CDT-D	CPM2A-60CDT-D	CPM1A-8ET	CPM1A-20EDT
Max. switching capacity	OUT01000, 01001: 4.5 to 30 V DC, 0.2 A/output OUT01002 and up: 4.5 to 30 V DC, 0.3 A/output					24 V DC <sup>+10%/−5%</sup> , 0.3 A/output
	0.8 A/common 1.6 A/Unit	0.8 A/common 2.4 A/Unit	0.8 A/common 3.2 A/Unit	0.8 A/common 4.8 A/Unit	0.9 A/common 1.8 A/Unit	0.9 A/common 1.8 A/Unit
Leakage current	0.1 mA max.					
Residual voltage	1.5 V max.					
ON delay	OUT01000 and OUT01001: 20 μs max. OUT01002 and up: 0.1 ms max.					0.1 ms max.
OFF delay	OUT01000 and OUT01001: 40 μs max. (4.5 to 26.4 V, 10 to 100 mA) 0.1 ms max. (4.5 to 30 V, 10 to 200 mA) OUT01002 and up: 1 ms max. (4.5 to 30 V, 10 to 300 mA)					1 ms max. (24 V DC <sup>+10%/−5%</sup> , 5 to 300 mA)
Fuse (see note)	1 fuse/output					
Circuit configuration	4.5 to 30 VDC, 0.3 A/output					

**Note:** Cannot be replaced by the user.

#### Transistor Output (Sourcing)

Item	Specification					
	CPM2A-20CDT1-D	CPM2A-30CDT1-D	CPM2A-40CDT1-D	CPM2A-60CDT1-D	CPM1A-8ET1	CPM1A-20DET1
Max. switching capacity	OUT01000, 01001: 4.5 to 30 V DC, 0.2 A/output OUT01002 and up: 4.5 to 30 V DC, 0.3 A/output					24 V DC <sup>+10%/−5%</sup> , 0.3 A/output
	0.8 A/common 1.6 A/Unit	0.8 A/common 2.4 A/Unit	0.8 A/common 3.2 A/Unit	0.8 A/common 4.8 A/Unit	0.9 A/common 1.8 A/Unit	0.9 A/common 1.8 A/Unit
Leakage current	0.1 mA max.					
Residual voltage	1.5 V max.					
ON delay	OUT01000 and OUT01001: 20 μs max. OUT01002 and up: 0.1 ms max.					0.1 ms max.
OFF delay	OUT01000 and OUT01001: 40 μs max. (4.5 to 26.4 V, 10 to 100 mA) 0.1 ms max. (4.5 to 30 V, 10 to 200 mA) OUT01002 and up: 1 ms max. (4.5 to 30 V, 10 to 300 mA)					1 ms max. (24 V DC <sup>+10%/−5%</sup> , 5 to 300 mA)
Fuse (see note)	1 fuse/output					
Circuit configuration	4.5 to 30 VDC, 0.3 A/output					

**Note:** Cannot be replaced by the user.

CPM1A-MAD□1

# Analog I/O units

## Handles 2 Analog Inputs and 1 Analog Output

- Resolution: up to 1/6000
- Conversion time: up to 2 ms per point

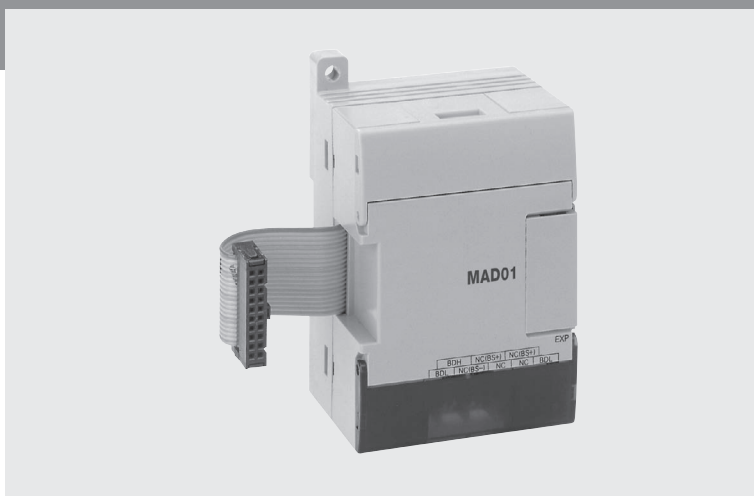

## Specifications

### General

Item		CPM1A-MAD01		CPM1A-MAD11	
		Voltage I/O	Current I/O	Voltage I/O	Current I/O
Analog inputs	Number of inputs	2		2 (allocated 2 words)	
	Input signal ranges	0 to 10 V or 1 to 5 V	4 to 20 mA	0 to 5 V, 1 to 5 V, 0 to 10 V, -10 to 10 V	0 to 20 mA, 4 to 20 mA
	Maximum rated input	±15 V	±30 mA	±15 V	±30 mA
	External input impedance	1 MΩ min.	250 Ω rated	1 MΩ min.	250 Ω
	Resolution	1/256		1/6,000 (full scale)	
	Overall precision	1.0% of full scale		25° C:±0.3% of full scale	25° C:±0.4% of full scale
				0 to 55° C:±0.6% of full scale	0 to 55° C:±0.8% of full scale
	Converted A/D data	8-bit binary		Binary data (4-digit hexadecimal) -10 to 10 V: F448 to 0BB8 Hex full scale Other:0000 to 1770 Hex full scale	
Averaging	---		Supported (set for each input with DIP switch)		
Disconnected line detection	---		Supported		
Analog output (See note 1.)	Number of outputs	1		1 (allocated 1 word)	
	Output signal ranges	0 to 10 V or -10 to 10 V	4 to 20 mA	1 to 5 V, 0 to 10 V, -10 to 10 V	0 to 20 mA, 4 to 20 mA
	External output max. current	5 mA		---	---
	External output allowed load resistance	---	350 Ω	1 kΩ min.	600 Ω max.
	External output impedance	---		0.5 Ω max.	---
	Resolution	1/256 (1/512 when the output signal range is -10 to 10 V.)		1/6,000 (full scale)	
	Overall precision	1.0% of full scale		25° C:±0.4% of full scale	0 to 55° C:±0.8% of full scale
	Data setting	8-bit binary with sign bit		---	
D/A data setting	---		Binary data (4-digit hexadecimal) -10 to 10 V: F448 to 0BB8 Hex full scale Other:0000 to 1770 Hex full scale		
Conversion time (See note 2.)	10 ms/Unit max.		2 ms/point (6 ms/all analog I/O)		
Isolation method	Photocoupler isolation between I/O terminals and PC (There is no isolation between the analog I/O signals.)		Photocoupler isolation between analog I/O and internal circuits. (Individual analog I/O signals are not isolated.)		

- Note:**
1. The voltage output and current output can be used at the same time, but the total output current cannot exceed 21 mA.
  2. The conversion time is the total time for 2 analog inputs and 1 analog output.

CPM1A-AD041/DA041

# Analog I/O units

## Handles 4 Analog Inputs or 4 Analog Outputs

- Conversion time: 2ms per point
- Resolution : 1/6000
- Range selection per Input/Output
- Averaging function (Inputs)
- Open circuit detection (Inputs)

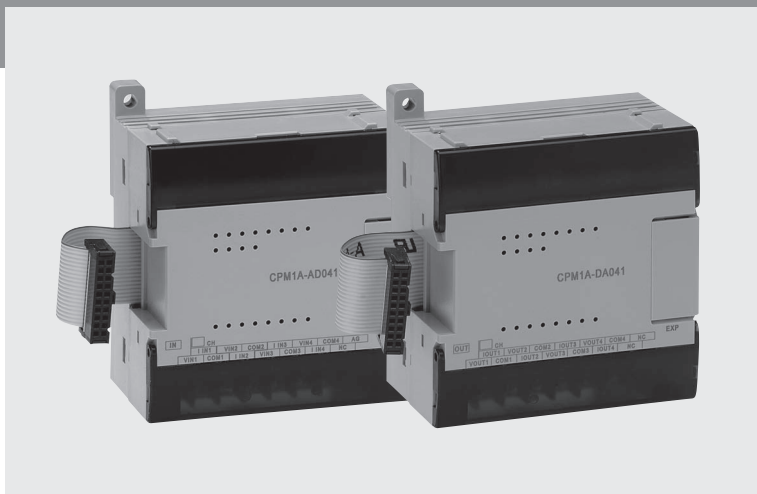

## Specifications

### General

Item	CPM1A-AD041		CPM1A-DA041	
	Voltage I/O	Current I/O	Voltage I/O	Current I/O
Analog inputs	Number of inputs	4 (allocated 4 words in + 2 words out)		
	Input signal ranges	0 to 5 V, 1 to 5 V, 0 to 10 V, -10 to 10 V	0 to 20 mA, 4 to 20 mA	
	Maximum rated input	±15 V	±30 mA	
	External input impedance	1 MΩ min.	250 Ω	
	Resolution	1/6,000 (full scale)		
	Overall precision	25°C:±0.3% of full scale 0 to 55°C:±0.6% of full scale	25°C:±0.4% of full scale 0 to 55°C:±0.8% of full scale	
	Converted A/D data	Binary data (4-digit hexadecimal) -10 to 10 V: F448 to 0BB8 Hex full scale Other:0000 to 1770 Hex full scale		
	Averaging	Supported (set for each input with DIP switch)		
Disconnection detection	Supported			
Analog output (See note 1.)	Number of outputs	4 (4 words allocated)		
	Output signal ranges		1 to 5 V, 0 to 10 V, -10 to 10 V	0 to 20 mA, 4 to 20 mA
	External output allowed load resistance		1 kΩ min.	600 Ω max.
	External output impedance		0.5 Ω max.	---
	Resolution	1/6,000 (full scale)		
	Overall precision	25°C:±0.4% of full scale 0 to 55°C:±0.8% of full scale		
D/A data setting	Binary data (hexadecimal, 4-digit) -10 to 10 V output range: Full scale = F448 to 0BB8 Hex Other output ranges: Full scale = 0000 to 1770 Hex			
Conversion time	2 ms/point		2 ms/point	
Isolation method	Photocoupler isolation between analog I/O and internal circuits. (Individual analog I/O signals are not isolated.)		Photocoupler isolation between analog I/O and internal circuits. (Individual analog I/O signals are not isolated.)	

CPM1A-TS□□

# Temperature Sensor Units

- By connecting a Temperature Sensor Unit (CPM1A-TS001/TS002/TS101/TS102, TS101-DA) to the CPM2A, inputs can be received from thermocouples or temperature-resistance thermometers.
- Inputs converted to binary data (4-digit hexadecimal) and stored in the IR area. Refer to page 76 for details on the maximum number of connectable Units.



## Specifications

### General

Item	Specification		
Model	CPM1A-TS001/002	CPM1A-TS101/102	CPM1A-TS101-DA
Number of inputs	TS001: 2; TS002: 4	TS101: 2; TS102: 4	2
Input types	K or J selectable (The same input type must be used for all inputs.)	Pt100, JPt100 selectable (The same input type must be used for all inputs.)	Pt100 only
Accuracy	±0.5% or ±2 °C of the stored value whichever is larger (see note) ± 1 digit max.	±0.5% or ±1 °C of the stored value whichever is larger (see note) ± 1 digit max.	1% of full scale
Conversion cycle	250 ms/2 points (TS001 or TS101) or 250 ms/4 points (TS002 or TS102)		60 ms (for all points)
Converted temperature data	Binary data (4-digit hexadecimal)		
Isolation method	Photocoupler isolation between input signals		
Number of outputs	---		one point
Output range	---		0 to 10 V, -10 to 10 V, 4 to 20 mA
Accuracy	---		1% of full scale

**Note:** Accuracy for K thermocouples at temperatures less than -100°C: ±4°C ± 1 digit max.

### Input Temperature Ranges for CPM1A-TS001/002

The input type is selected with a rotary switch. The ranges for each of the input types are shown in the following table.

Item	Range in °C	Range in °F
K	-200 to 1,300	-300 to 2,300
	0.0 to 500.0	0.0 to 900.0
J	-100 to 850	-100 to 1,500
	0.0 to 400.0	0.0 to 750.0

### Input Temperature Ranges for CPM1A-TS101/102

The input type is selected with a rotary switch. The ranges for each of the input types are shown in the following table.

Item	Range in °C	Range in °F
Pt100	-200.0 to 650.0	-300 to 1,200.0
JPt100	-200.0 to 650.0	-300 to 1,200.0

### Input Temperature Ranges for CPM1A-TS101-DA

The input type is selected with a rotary switch. The ranges for each of the input types are shown in the following table.

Item	Range in °C
Pt100	-40.0 to 250.0

CPM1A-DRT21

# DeviceNet I/O Link Unit

## I/O Link Unit for CPM2A/CPM1A PLCs

- Functions as a slave for DeviceNet.
- Provides 32 input points and 32 output points for I/O exchange with the master.
- International standards: UL, CSA, CE.

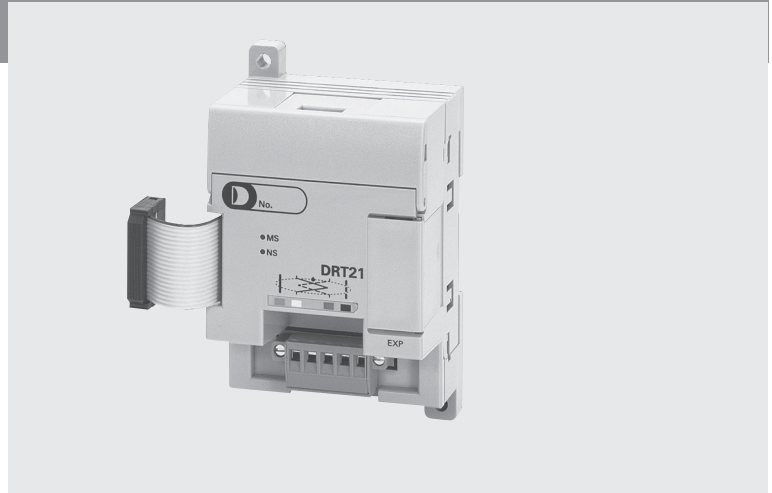

## Specifications

Communications power supply voltage	11 to 25 V DC
Current consumption	10 mA max. at 24 V DC
Max. number of I/O points	Inputs: 32; Outputs: 32
Number of allocated words in CPM2A I/O memory	Input: 2 words; Output: 2 words (Same allocation as for other Expansion Units.)
Node address setting method	Set using DIP switch.
Max. number of connectable Units	3 max.

## Application Examples

### Configuration Example

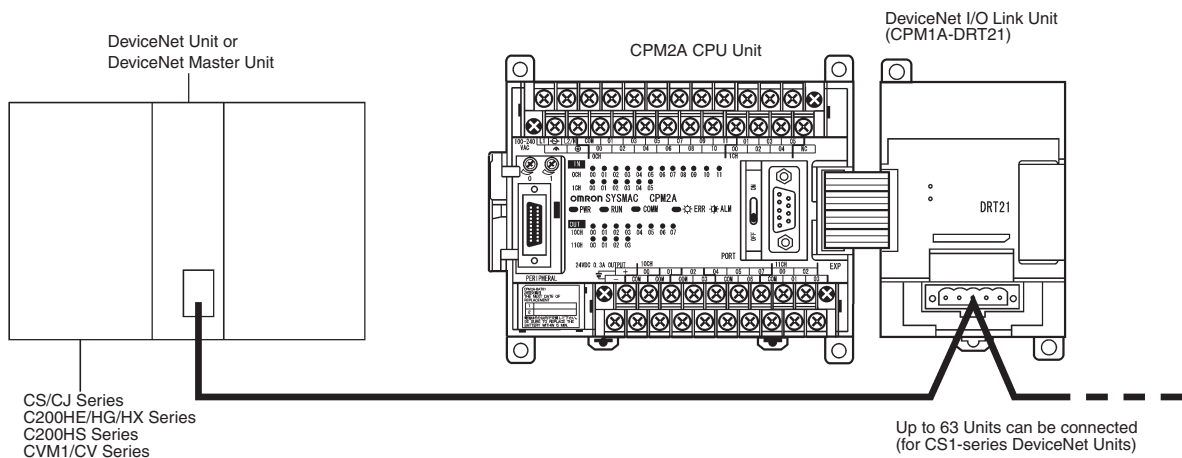

**Note:** Up to 3 DeviceNet I/O Link Units and other Expansion I/O Units can be mounted to CPM1A/CPM2A CPU Units.

## Precautions

Refer to the relevant catalog for details on CPM1A and CPM2A PLCs (CPM1: Cat. No. P035; CPM2A/CPM2C: Cat. No. P049).

CPM1A-PRT21

# PROFIBUS-DP I/O Link Unit

## I/O Link Unit for CPM2A/CPM1A PLCs

- Functions as a slave for PROFIBUS-DP.
- Provides 16 input points and 16 output points for I/O exchange with the PROFIBUS-DP master.



## Specifications

Item	Specification
Model number	CPM1A-PRT21
Master/slave	PROFIBUS-DP slave (OC_0658.GSD)
I/O capacity to master	16 input und 16 output points (no consistency), Intel/Motorola format selectable by DIP switch.
I/O memory allocated in CPM2A	1 input word and 1 output word (allocated in the same as other Expansion Units)
Node address setting	2 rotary switches (00-99)
Maximum number of nodes per PROFIBUS network	C200H master, CS1 / CJ1 master: 125 nodes

## Application Examples

### Configuration Example

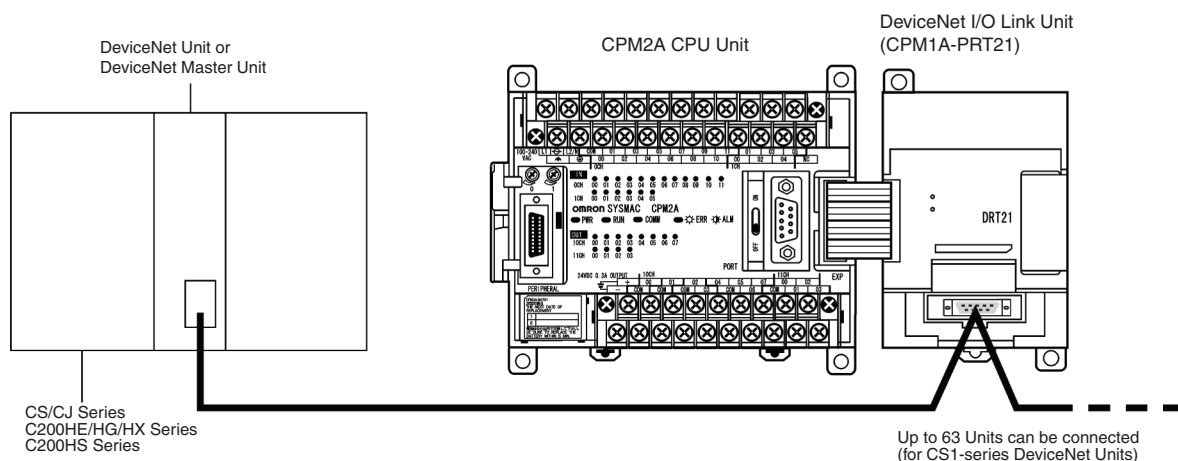

**Note:** Up to 3 PROFIBUS DP I/O Link Units and other Expansion I/O Units can be mounted to CPM1A/CPM2A CPU Units.

## Precautions

Refer to the relevant catalog for details on CPM1A and CPM2A PLCs (CPM1: Cat. No. P035; CPM2A/CPM2C: Cat. No. P049).

I/O Link Unit CPM1A-SRT21

# CompoBus/S I/O Link Unit

### I/O Link Unit for CPM2A/CPM1A PLCs

- Operates as a Slave of the CompoBus/S Master Unit.
- Exchanges eight inputs and eight outputs with the Master.
- Approved by UL and CSA standards, and bears the CE marking.



## Specifications

Master/Slave	CompoBus/S Slave
Number of I/O points	8 inputs and 8 outputs
Number of words occupied in CPM2A's I/O memory	1 input word and 1 output word (allocated in the same way as for other Expansion Units)
Node address setting	DIP switch

**Note:** For details of CPM1A PLCs, refer to the CPM1A catalog (Cat. No. P039). For details of CPM2A PLCs, refer to the CPM2A catalog (Cat. No. P049)

## Installation

### Connection Examples

CompoBus/S Master Unit or SRM1  
CompoBus/S Master Control Unit

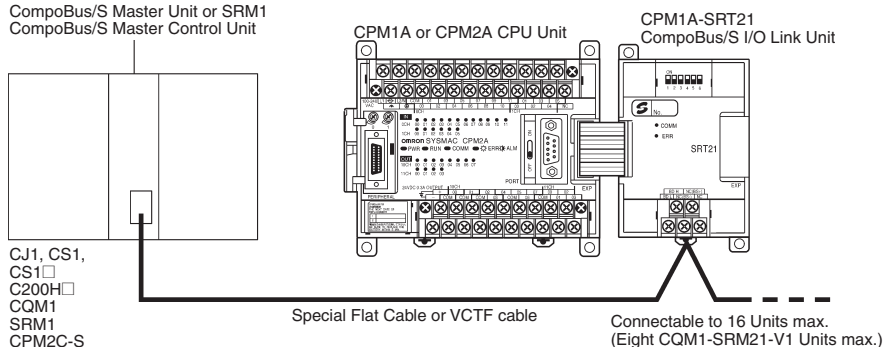

**Note:** A single CompoBus/S I/O Link Unit together with a maximum of two other Expansion I/O Units can be connected to the CPM1A or CPM2A CPU Unit.

# CPM2A General Information

## System Configuration

Up to three Expansion I/O Units or Expansion Units can be connected to a CPM2A CPU Unit. Group 2 Units are counted as 2 Expansion Units; therefore only one Group 2 Unit can be connected per CPU.

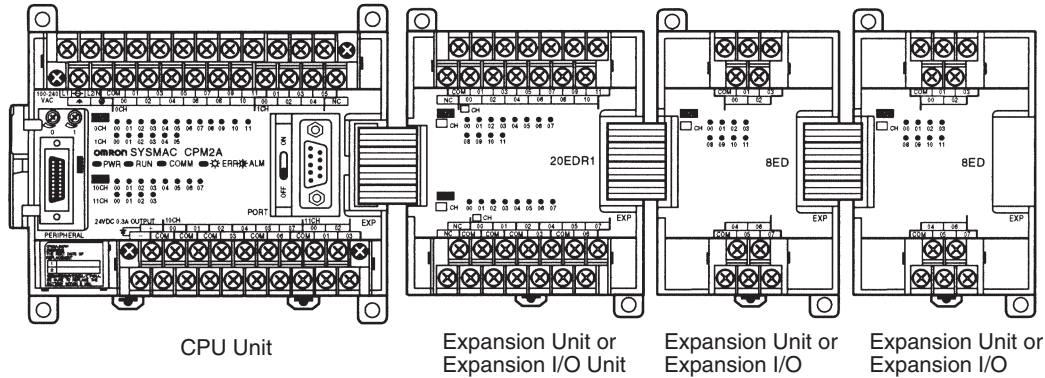

### Expansion Unit Connection Groups

Group 1 (G1)	Group 2 (G2)
Expansion I/O Units Analog I/O Units CompoBus/S I/O Link Units CPM1A-TS001/TS101(-DA) Temperature Sensor Units DeviceNet I/O Link Unit PROFIBUS-DP I/O Link Unit	CPM1A-TS002/TS102 Temperature Sensor Units CPM1A-AD041/DA041 Analog I/O Units

The sequences in which Units in the above groups can be connected to the CPU Unit are shown in the following table.

### Expansion Unit Group Combinations

Expansion sequence 1	Expansion sequence 2	Expansion sequence 3
G1	G1	G1
G2	G1	G2 Units cannot be connected after a G1 Unit.

- Note:**
- The mounting sequence does not affect the number of Units that can be mounted.
  - If the NT-AL001 RS-422 Adapter is connected to the RS-232C port, only one Expansion Unit or Expansion I/O Unit can be added.
  - If three CPM1A-MAD11/MAD01 Analog I/O Units are connected to a CPM2A-60CDR-A CPU Unit, keep the output capacity of the external power supply (24 V DC) to 200 mA or less.

# Dimensions

## CPM2A-20CD□-□/30CD□-□ CPU Units

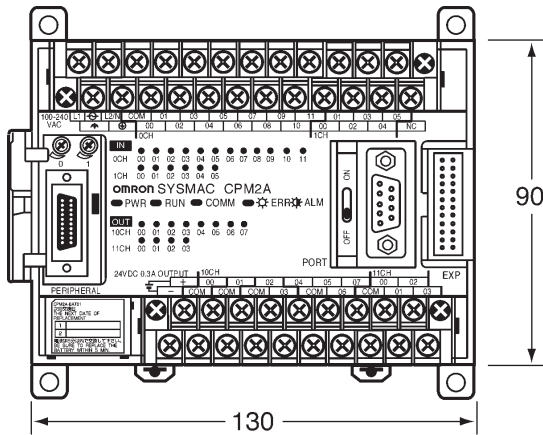

CPU Units with DC Power

CPU Units with AC Power

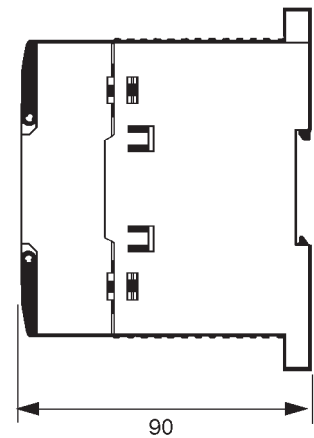
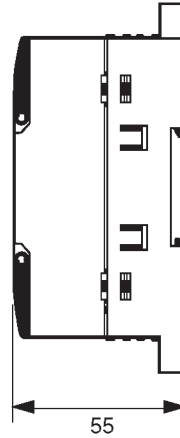

## CPM2A-40CD□-□ CPU Units

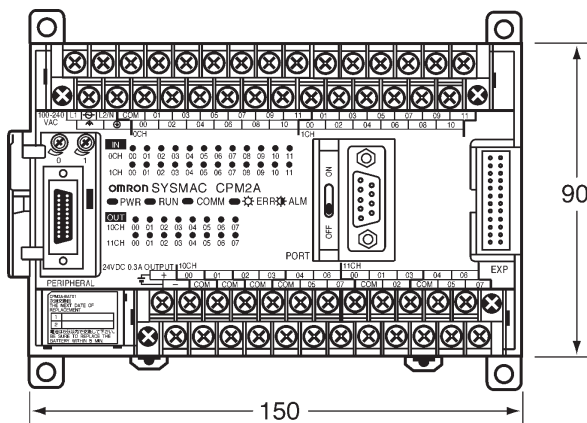

CPU Units with DC Power

CPU Units with AC Power

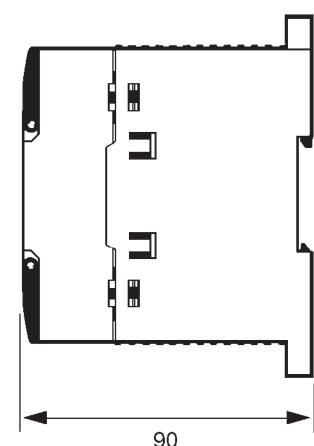
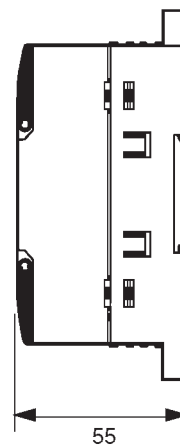

## CPM2A-60CD□-□ CPU Units

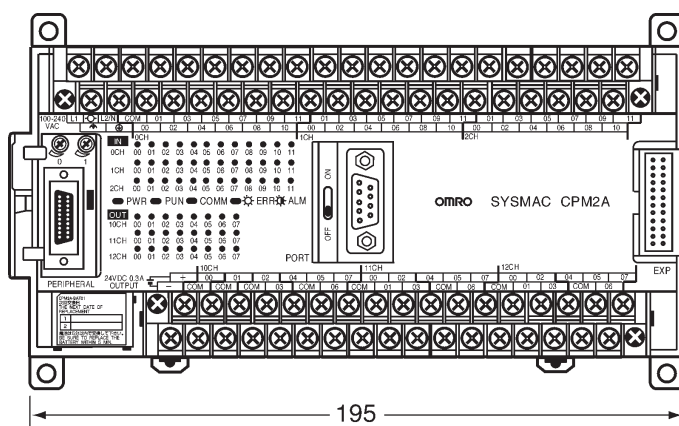

CPU Units with DC Power

CPU Units with AC Power

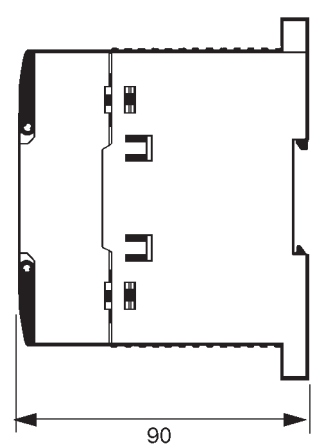
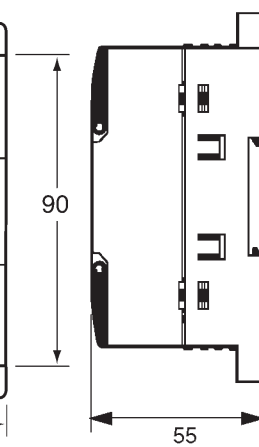

Note: All dimensions are in mm.

CPM1A-20ED Expansion I/O Units

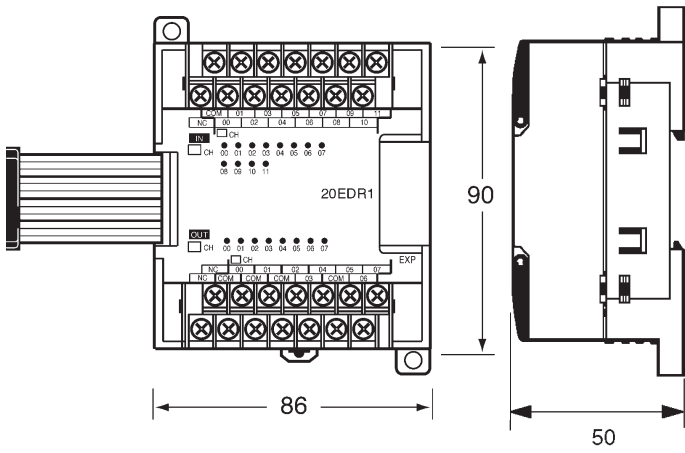

CPM1A-8 Expansion I/O Units

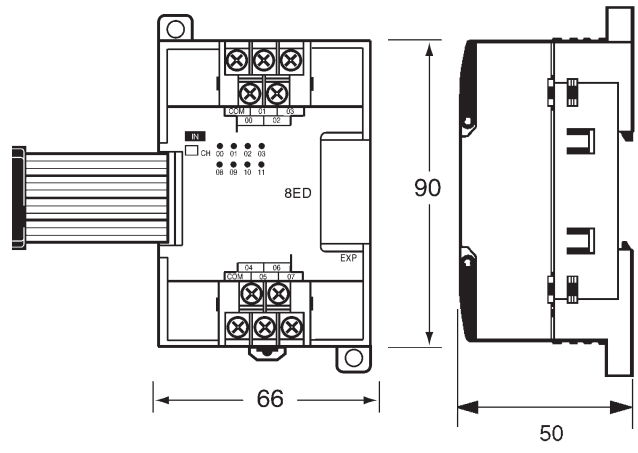

CPM1A-DRT21 DeviceNet I/O Link Unit  
CPM1A-PRT21 PROFIBUS-DP I/O Link Unit

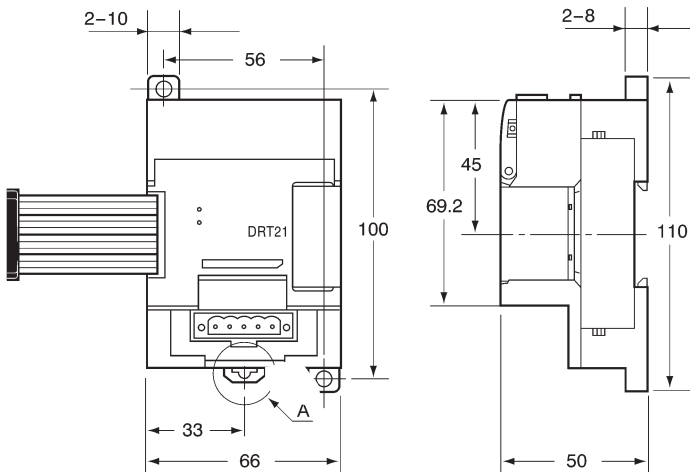

CPM1A-SRT21 CompoBus/S I/O Link Unit

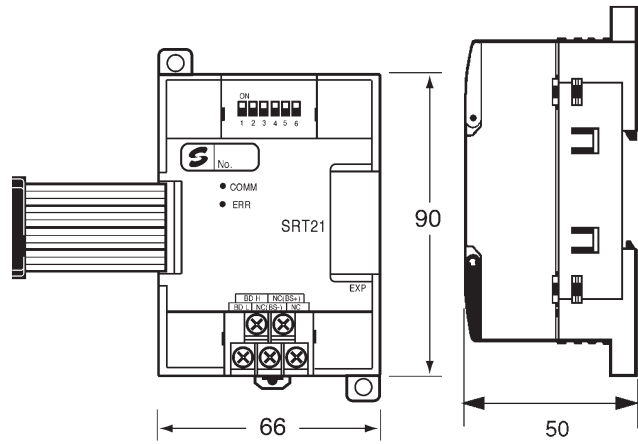

CPM1A-MAD01 Analog I/O Unit

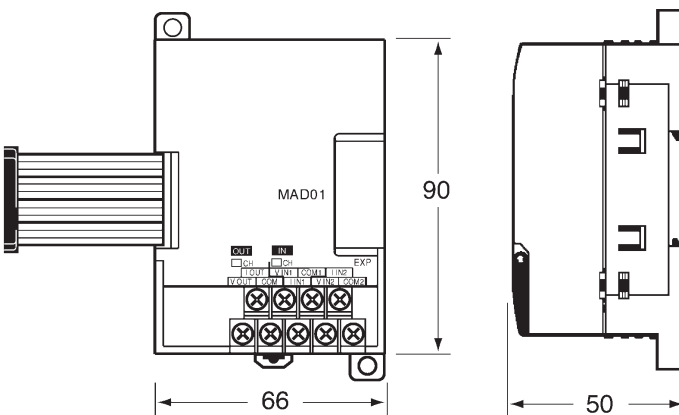

CPM1A-MAD11 Analog I/O Unit

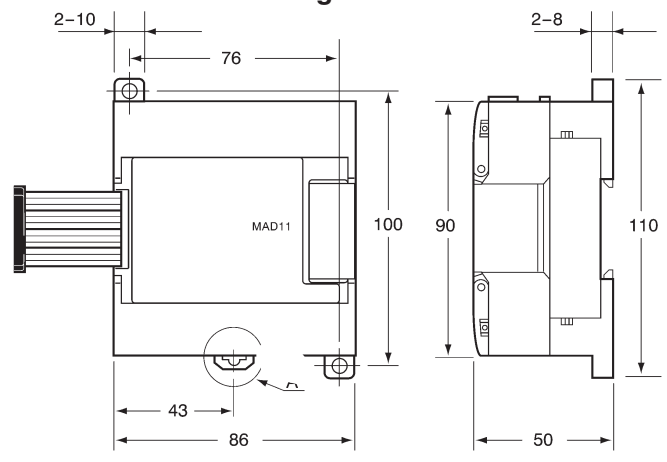

Note: All dimensions are in mm.

**CPM1A-TS□□□□ Temperature Sensor Unit**  
**CPM1A-AD041/DA041 Analog I/O Units**

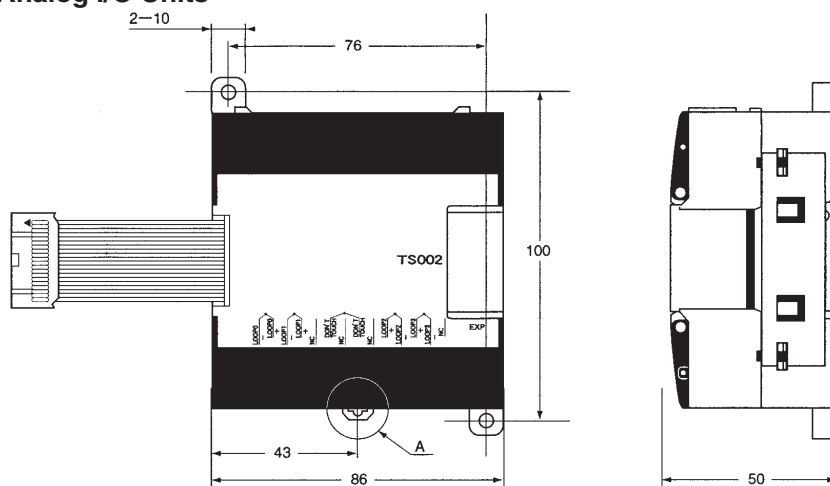

**Note:** All dimensions are in mm.

**CPM1-CIF01 RS-232C Adapter**

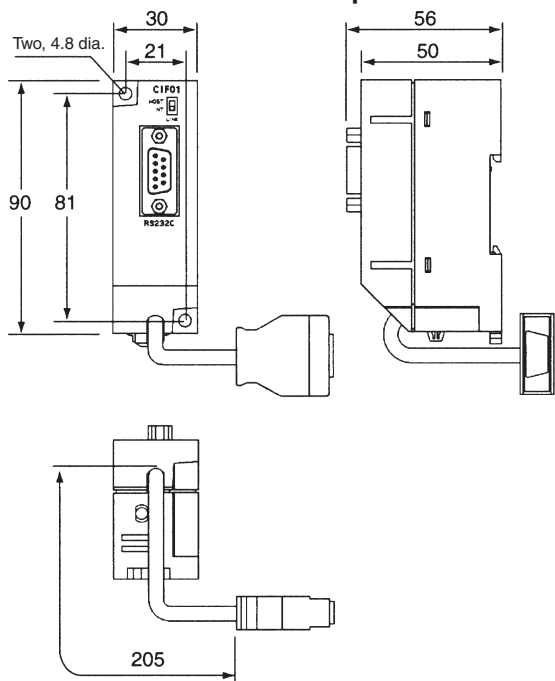

**CPM1-CIF11 RS-422 Adapter**

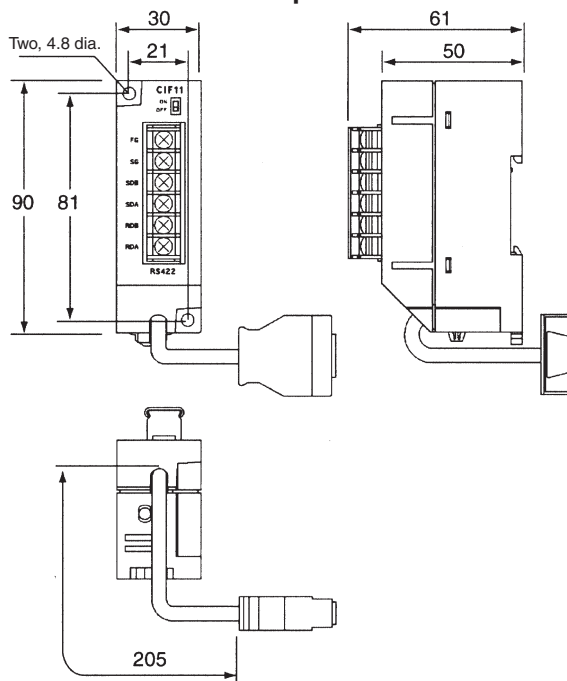

# CPM2A Ordering Information

## International Standards

The products shown in the attached tables are those that conform to the UL, CSA, cULus, cUL, NK, Lloyd's Register, and EC Directives as of September 2003.

(U: UL, C: CSA, UC: cULus, CU: cUL, N: NK, L: Lloyd, CE: EC Directives)

Please contact OMRON representative for application conditions.

## CPM2A CPU Units

CPU Unit	Power supply	Output type	Inputs	Outputs	Model	Standards
20 I/O points	AC	Relay	12	8	CPM2A-20CDR-A	U, C, CE, N, L
	DC	Relay			CPM2A-20CDR-D	U, C, CE, N, L
		Transistor (sinking)			CPM2A-20CDT-D	U, C, CE, N, L
		Transistor (sourcing)			CPM2A-20CDT1-D	U, C, CE, N, L
30 I/O points	AC	Relay	18	12	CPM2A-30CDR-A	U, C, CE, N, L
	DC	Relay			CPM2A-30CDR-D	U, C, CE, N, L
		Transistor (sinking)			CPM2A-30CDT-D	U, C, CE, N, L
		Transistor (sourcing)			CPM2A-30CDT1-D	U, C, CE, N, L
40 I/O points	AC	Relay	24	16	CPM2A-40CDR-A	U, C, CE, N, L
	DC	Relay			CPM2A-40CDR-D	U, C, CE, N, L
		Transistor (sinking)			CPM2A-40CDT-D	U, C, CE, N, L
		Transistor (sourcing)			CPM2A-40CDT1-D	U, C, CE, N, L
60 I/O points	AC	Relay	36	24	CPM2A-60CDR-A	U, C, CE, N, L
	DC	Relay			CPM2A-60CDR-D	U, C, CE, N, L
		Transistor (sinking)			CPM2A-60CDT-D	U, C, CE, N, L
		Transistor (sourcing)			CPM2A-60CDT1-D	U, C, CE, N, L

## Expansion Units and Expansion I/O Units

Unit	Input/Output type	Inputs	Outputs	Model	Standards	
Expansion I/O Units	Relay	24	16	CPM1A-40EDR	CE, N	
	Transistor (sinking)			CPM1A-40EDT	CE, N	
	Transistor (sourcing)			CPM1A-40EDT1	CE, N	
	Relay	12	8	CPM1A-20EDR1	U, C, CE, N, L	
				Transistor (sinking)	CPM1A-20EDT	U, C, CE, N, L
				Transistor (sourcing)	CPM1A-20EDT1	U, C, CE, N, L
	---	8	---	CPM1A-8ED	U, C, CE, N, L	
	Relay	---	8	CPM1A-8ER	U, C, CE, N, L	
	Transistor (sinking)	---	8	CPM1A-8ET	U, C, CE, N, L	
	Transistor (sourcing)	---	8	CPM1A-8ET1	U, C, CE, N, L	
Analog I/O Unit	Analog (resolution: 1/256)	2	1	CPM1A-MAD01	U, C, CE	
	Analog (resolution: 1/6,000)	2	1	CPM1A-MAD11	U, C, CE	
	Analog (resolution 1/6000)	4	---	CPM1A-AD041	U, C, CE	
	Analog (resolution 1/6000)	---	4	CPM1A-DA041	U, C, CE	
DeviceNet I/O Link Unit	---	I/O Link of 32 input bits and 32 output bits		CPM1A-DRT21	U, C, CE	
PROFIBUS-DP I/O Link Unit	---	I/O Link of 16 input bits and 16 output bits		CPM1A-PRT21	CE	
CompoBus/S I/O Link Unit	---	I/O Link of 8 input bits and 8 output bits		CPM1A-SRT21	U, C, CE, N, L	
Temperature Sensor Units	2 thermocouple inputs			CPM1A-TS001	U, C, CE, N, L	
	4 thermocouple inputs			CPM1A-TS002	U, C, CE, N, L	
	2 platinum resistance thermometer inputs			CPM1A-TS101	U, C, CE, N, L	
	4 platinum resistance thermometer inputs			CPM1A-TS102	U, C, CE, N, L	
	2 Platinum resistance thermometer inputs (-40 to 250 °C) and one output (-10 to 10V, 4 to 20 mA)			CPM1A-TS101-DA	U, C, CE, N, L	

### Programming Consoles and Cables

Product	Model	Standards
Programming Console (2-m cable attached)	CQM1H-PRO01-E	U, C, N, CE
Programming Console (Requires separate cable. See below.)	C200H-PRO27-E	U, C, N, CE
Connecting Cable for C200H-PRO27-E	2-m cable	C200H-CN222
	4-m cable	C200H-CN422

### Support Software

Product	Functions	Model	Standards
CX-One	Omron's integrated software for programming and configuration of all control system components, including PLCs, HMI, drives, temperature controllers and advanced sensors.	CX-ONE-AL□□C-E <sup>*1</sup>	---

\*1 □□ = Number of licenses (01, 03, 10)

Product	Model	Standards
Expansion Memory Unit	CPM1-EMU01-V1	---
EEPROM (256 K)	EEROM-JD	---

### Personal Computer Connecting Cables

CPM2A port	Computer port	Specifications	Cable length	Model	Standards
Peripheral	For a D-sub 9-pin port	---	3.3 m	CQM1-CIF02	U, C, N, L, CE
RS-232C	For a D-sub 9-pin port	Can be used with a peripheral bus or Host Link. Uses connector that prevents ESD (electrostatic discharge.)	2 m	XW2Z-200S-V	---
			5 m	XW2Z-500S-V	---
			2 m	XW2Z-200S-CV	---
			5 m	XW2Z-500S-CV	---
			2 m	XW2Z-200S	---
			5 m	XW2Z-500S	---
	For a D-sub 25-pin port	---	2 m	XW2Z-200S	---
	For a half-pitch 14-pin port	---	2 m + 0.15 m	XW2Z-200S	---
			5 m + 0.15 m	XW2Z-S001	---

### Adapters

Product	Function	Model	Standards
RS-232C Adapter	Peripheral port level conversion	CPM1-CIF01	N, L, CE
RS-422 Adapter		CPM1-CIF11	N, L, CE
Link Adapter	RS-232C to RS-422A conversion	3G2A9-AL004-E	---
RS-232C to RS422A Conversion Adapter		NT-AL001	---

### Battery

Product	Function	Model	Standards
Backup Battery (See note.)	Backs up memory in the CPM2A CPU Unit.	CPM2A-BAT01	---

**Note:** One internal Backup Battery is provided as standard.

Board PLC

# CPM2B

**Proven PLC technology, made to fit anywhere.**

**Fits into the narrowest slots.**

Requiring only 45-mm height, the CPM2B easily fits into narrow spaces.

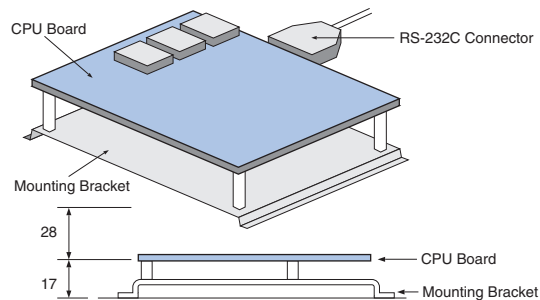
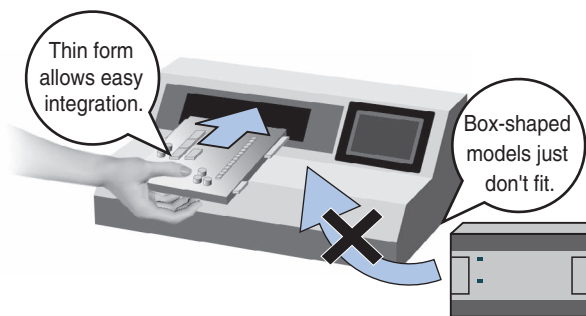

**Note:** Dimensions using a CPU Board. Horizontal expansion using CPM2B-CN411 Cable with an Expansion Board is possible.

**Full integration into your machine**

The case-free board format of the CPM2B can be used like an in-house controller.

## Conventional PLC

Company A or Company B PLC built in as specified by end user.



## CPM2B

The board shape solves problems with end user specifications, eliminating the need to build in PLCs from different companies.

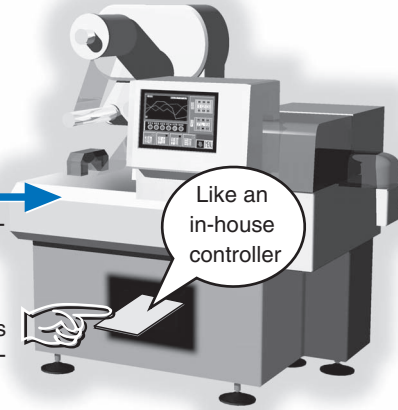

### 12-V Power Supply

Lineup includes Board PLCs that support a 12-V power supply, allowing battery-powered applications, such as notification of power failures via wireless error information transmissions.

- 32-point CPU Board (transistor outputs)
- 32-point Expansion I/O Board (transistor outputs)

### Use with Devices Requiring Analog I/O

- Lineup includes Analog I/O Expansion Boards (Resolution: 6,000)
- Use to set speed and other settings for Pressure Sensors and Inverters.

**Provides Machine Control Functions**

**Includes Two High-speed Counter Functions**

One high-speed counter input can be used in any one of the four input modes: Differential phase pulse mode (5 kHz), pulse plus direction input mode (20 kHz), up/down pulse input mode (20 kHz), and increment mode (20 kHz). The four interrupt inputs in counter mode can be used for incrementing counters or decrementing counters (2 kHz).

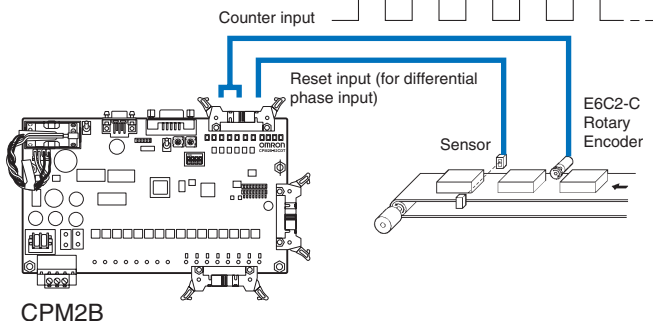

**Reliably Reads Short Pulses of 50 μs**

Quick-response input allows short ON-time pulse input. Four inputs are used for quick-response inputs (shared with interrupt inputs and interrupt inputs in counter mode) that can reliably read inputs with a minimum input signal width as short as 50 μs, regardless of the cycle time.

**Analog Settings**

Two controls on the CPU Board can be turned to change the analog settings. The rotation angle is stored as BCD data (0 to 200 BCD) in IR 250 and IR 251. These controls can be used to easily change or fine-tune machine settings such as a conveyor belt's pause time or feed rate.

**Calendar/Clock**

CPU Boards that have a built-in clock (accuracy: 1 minute/month), can read from the program to show the current year, month, day, day of the week, and time (hour, minute, second).

**Easy Position Control with Pulse Outputs**

(Transistor Outputs Only)

CPM2B PLCs with transistor outputs have two outputs that can produce 10-Hz to 10-kHz pulses (single-phase outputs).

- When used as single-phase pulse outputs, there can be two outputs. When used as pulse plus direction or up/down pulse outputs, there can be just one output. Output of 0.1 to 999.9 Hz with a variable duty ratio (0 to 100% duty ratio) is also possible.

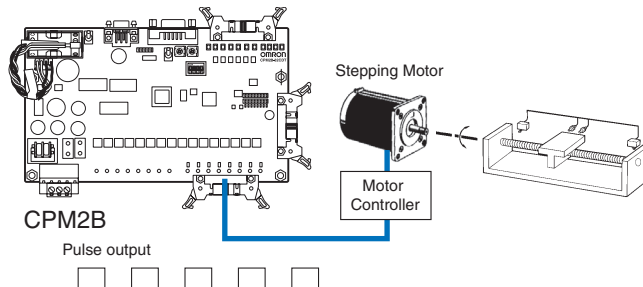

**Indispensable interrupt Functions for Machine Control**

When an interrupt input goes ON, the main program is stopped and the interrupt program is executed. The interrupt functions can be used as high-speed counters and for quick response, in addition to timer functions.

**High-speed Communications with the PT Using a 1:1 NT Link**

With a 1:1 NT Link, an OMRON Programmable Terminal (PT) can be connected directly to the CPM2B.

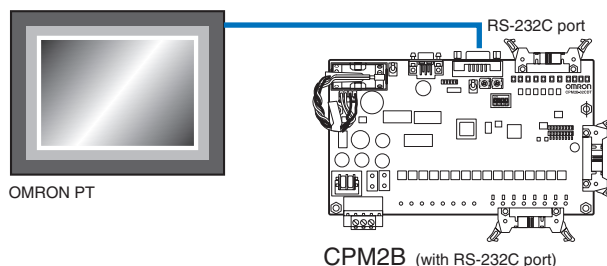

**Device Connections and System Configuration**

**•CX-Programmer (CX-One)**

(Compatible with version 1.2 or later.)

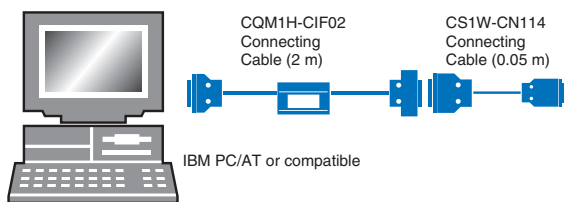

**•Programming Console**

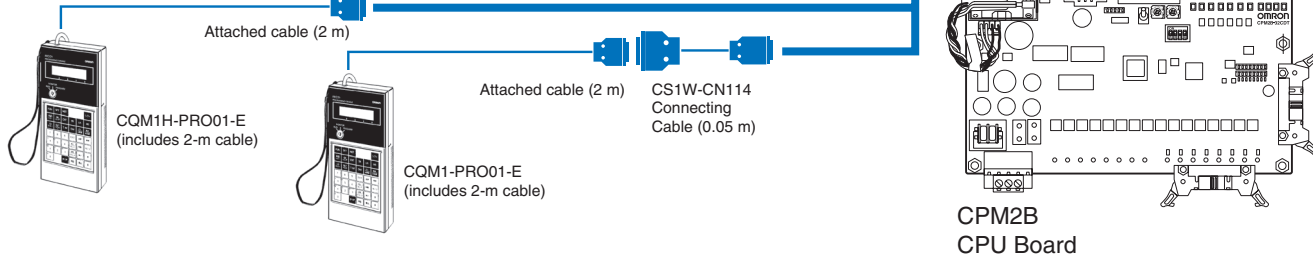

CPU Boards

Board type		Inputs	Outputs	Battery	Clock	RS-232C port	Model
32 I/O points (16 inputs, 16 outputs)	Terminal block outputs	16 inputs, 24 V DC	16 relay outputs	---	---	---	CPM2B-32C1DR-D
				●	●	●	CPM2B-32C2DR-D
	Connector outputs	16 inputs, 24 V DC	16 sinking transistor outputs	---	---	---	CPM2B-32C1DT-D
				●	●	●	CPM2B-32C2DT-D
40 I/O points (24 inputs, 26 outputs)	Terminal block outputs	16 inputs, 12 V DC	16 sinking transistor outputs	---	---	---	CPM2B-32C1D1T-D12
				●	●	●	CPM2B-32C2D1T-D12
	Connector outputs	24 inputs, 24 V DC	16 relay outputs	●	●	●	CPM2B-32C2D1T-D12
				●	●	●	CPM2B-40C2DR-D

Expansion I/O Boards

Board type		Inputs	Outputs	Model
32 I/O points (16 inputs, 16 outputs)	Terminal block outputs	16 inputs, 24 V DC	16 relay outputs	CPM2B-32EDR
	Connector outputs	16 inputs, 24 V DC	16 sinking transistor outputs	CPM2B-32EDT
		16 inputs, 12 V DC	16 sinking transistor outputs	CPM2B-32ED1T
40 I/O points (24 inputs, 26 outputs)	Terminal block outputs	24 inputs, 24 V DC	16 relay outputs	CPM2B-40EDR
64 I/O points (32 inputs, 32 outputs)	Connector output	32 inputs, 24 V DC	32 sinking transistor outputs	CPM2B-64EDT

- Note:**
1. A maximum of two CPM2B-64EDT 64-point Expansion I/O Boards can be connected, due to the current consumption.
  2. Only one Expansion I/O Board can be connected if connecting an NT-AL001 to the RS-232C port.

General Specifications

Item	CPU Board		Expansion Board	
	32 or 40 I/O points (relay output)	32 I/O points (transistor output)	32 or 64 I/O points (relay output)	32 or 64 I/O points (transistor output)
Supply voltage	24 V DC		Supplied from the CPU Board	
Allowable supply voltage	20.4 to 26.4 V DC			
Power consumption	20 W max.		---	
Inrush current	20 A max.		---	
Insulation resistance	20 MW min. (at 500 V DC) between the external DC terminals and non-current carrying metal parts			
Dielectric strength	1,000 V AC for 1 min between the external DC terminals and non-current carrying metal parts			
Noise immunity	Conforms to IEC61000-4-4; 2 kV (power lines)			
Vibration resistance	Conforms to JIS C0040. 10 to 57 Hz, 0.075 mm amplitude, 57 to 150 Hz, 9.8 m/s <sup>2</sup> acceleration in X, Y and Z directions for 80 minutes each (8 minutes of vibration x 10 repetitions = total time 80 minutes)			
Shock resistance	Conforms to JIS C0041, 147 m/s <sup>2</sup> three times each in X, Y and Z directions			
Ambient operating temperature	0 to 55 °C			
Ambient operating humidity	10% to 90% (with no condensation)			
Ambient operating atmosphere	Must be free from corrosive gas.			
Ambient storage temperature	-20 to 75 °C (excluding the battery)			
Power supply retention time	2 ms min.			

Performance Specifications

		CPU Board
Item		32 I/O points (relay outputs) 32 I/O points (transistor outputs) 40 I/O points (relay outputs)
Control method		Stored program method
I/O control method		Cyclic scan (immediate refreshing can be performed with IORF/97.)
Programming language		Ladder diagram
Instruction length		1 step per instruction, 1 to 5 words per instruction
Instructions	Basic instructions	14 instructions
	Special instructions	105 instructions, 185 variations
Execution time	Basic instructions	0.64 ms (LD instruction)
	Special instructions	7.8 ms (MOV instruction)
Program capacity		4,096 words
Max. I/O capacity	CPU Board only	32 points/40 points
	With Expansion I/O Boards	168 points max.
Input bits	IR 00000 to IR 00915 (Words not used for input bits can be used for work bits).	
Output bits	IR 01000 to IR 01915	
Work bits	928 bits: IR 02000 to IR 04915 (words IR 020 to IR 049) and IR 20000 to IR 22715 (words IR 200 to IR 227)	
Special bits (SR Area)	448 bits: IR 22800 to IR 25515 (words IR 228 to 256)	
Temporary bits (TR Area)	8 bits (TR0 to TR7)	
Holding bits (HR Area)	320 bits: HR 0000 to HR 1915 (words HR 00 or HR 19)	
Auxiliary bits (AR Area)	384 bits: AR 0000 to AR 2315 (words AR 00 to AR 23)	
Link bits (LR Area)	256 bits: LR 0000 to LR 1515 (words LR 00 to LR 15)	
Timers/Counters	256 bits: TIM/CNT 000 to TIM/CNT 255 1-ms timers: TMHH                      10-ms timers: TIMH 100-ms timers: TIM                      1-s/10-s timers: TIML Decrementing timers: CNT              Reversible counters: CNTR	
Data memory	Read/Write	2,048 words (DM 0000 to DM 2047). The Error Log is contained in DM 2000 to DM 2021.
	Read only	456 words (DM 6144 to DM 6599)
	PLC Setup	54 words (DM 6600 to DM 6655)

Assembly Dimensions

32 or 64 I/O points

- Front View

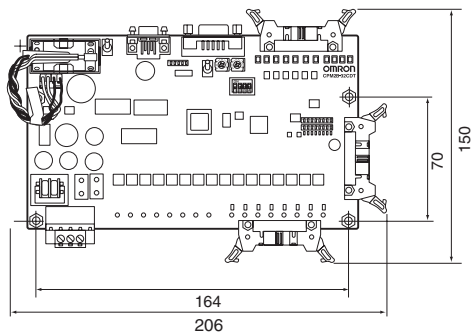

- Height (When Stacked Vertically)

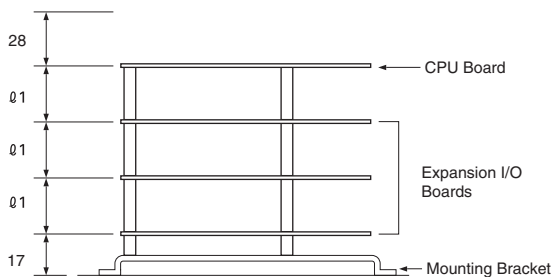

	32-point Expansion I/O Boards	32/64-point Expansion I/O Boards
#1	28 mm	24 mm

Compact PLC series

# CPM2C

A versatile controller for up to 192 I/O points in an ultra-compact package

## SYSMAC CPM2C

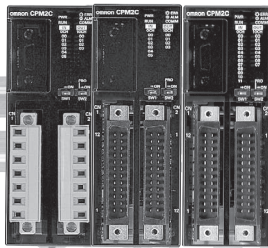

An extensive range of models assures efficient machine control in an ultracompact package. CPU Units (DC power supply only) are available with relay or transistor output, terminal block or various connector options, and an optional real-time clock function. Select the output type, number of I/O points and other specifications to meet your needs. Expansion I/O Units with 8 to 32 I/O points make it possible to configure a control system with a maximum of 192 I/O points.

CPU Units Depth: 65 mm

10 I/O Points



- Relay Output CPU Units (Terminal-block type)  
CPM2C-10CDR-D (No clock)  
CPM2C-10C1DR-D (Clock)
- Input points: 6, DC input
- Output points: 4



- Transistor Output (Sink) CPU Units (Connector type)  
CPM2C-10CDT1C-D (No clock)  
CPM2C-10C1DTC-D (Clock)  
(MIL-connector type)  
CPM2C-10CDTM-D (No clock)  
CPM2C-10C1DTM-D (Clock)

- Transistor Output (Source) CPU Units (Connector type)  
CPM2C-10CDT1C-D (No clock)  
CPM2C-10C1DT1C-D (Clock)  
(MIL-connector type)  
CPM2C-10CDT1M-D (No clock)  
CPM2C-10C1DT1M-D (Clock)
- Input points: 6, DC input
- Output points: 4

20 I/O Points



- Relay Output CPU Units (Terminal-block type)  
CPM2C-20CDR-D (No clock)  
CPM2C-20C1DR-D (Clock)
- Input points: 12, DC input
- Output points: 8



- Transistor Output (Sink) CPU Units (Connector type)  
CPM2C-20CDT1C-D (No clock)  
CPM2C-20C1DTC-D (Clock)  
(MIL-connector type)  
CPM2C-20CDTM-D (No clock)  
CPM2C-20C1DTM-D (Clock)

- Transistor Output (Source) CPU Units (Connector type)  
CPM2C-20CDT1C-D (No clock)  
CPM2C-20C1DT1C-D (Clock)  
(MIL-connector type)  
CPM2C-20CDT1M-D (No clock)  
CPM2C-20C1DT1M-D (Clock)
- Input points: 12, DC input
- Output points: 8

32 I/O Points



- Transistor Output (Sink) CPU Units (Connector type)  
CPM2C-32CDT1C-D (No clock)  
(MIL-connector type)  
CPM2C-32CDTM-D (No clock)

- Transistor Output (Source) CPU Units (Connector type)  
CPM2C-32CDT1C-D (No clock)  
(MIL-connector type)  
CPM2C-32CDT1M-D (No clock)
- Input points: 16, DC input
- Output points: 16

Programmable DeviceNet Slaves

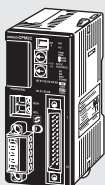

- Transistor Output (Sink) CPU Unit (Connector type)  
CPM2C-S100C-DRT (Clock)
- Transistor Output (Source) CPU Unit (Connector type)  
CPM2C-S110C-DRT (Clock)
- Input points: 6, DC input
- Output points: 4

CPU Units with CompoBus/S Master Function



- Transistor Output (Sink) CPU Unit (Connector type)  
CPM2C-S100C (Clock)
- Transistor Output (Source) CPU Unit (Connector type)  
CPM2C-S110C (Clock)
- Input points: 6, DC input
- Output points: 4

AC Power Supply Unit

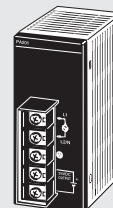

- CPM2C-PA201
- 100- to 240-V AC input
- 24-V AC/600-mA output

Analog I/O Units



- CPM2C-MAD11
- Analog inputs: 2 (Resolution: 6,000)
- Analog output: 1 (Resolution: 6,000)

Temperature Sensor Units



- CPM2C-TS001
- Thermocouple inputs: 2
- CPM2C-TS101
- Platinum-resistance thermometer inputs: 2

CompoBus/S I/O Link Unit



- CPM2C-SRT21
- I/O Link inputs: 8
- I/O Link outputs: 8

Simple Communications Unit

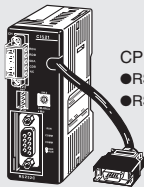

- CPM2C-CIF21
- RS-485 component connection
- RS-232C

Adapters

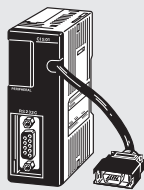

- Peripheral/RS-232C Adapter CPM2C-CIF01-V1

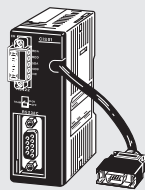

- RS-422/RS-485 + RS-232C Adapter CPM2C-CIF11

Expansion I/O Units Depth: 65 mm

Input/Output Expansion I/O Units



- Relay Output I/O Unit (Terminal-block type) CPM2C-10EDR
- Input points: 6, DC input
- Output points: 4



- Relay Output I/O Unit (Terminal-block type) CPM2C-20EDR
- Input points: 12, DC input
- Output points: 8



- Transistor Output (Sink) I/O Unit (Connector type) CPM2C-24EDTC

- Transistor Output (Source) I/O Unit (Connector type) CPM2C-24EDT1C

- Transistor Output (Sink) I/O Unit (MIL-connector type) CPM2C-24EDTM

- Transistor Output (Source) I/O Unit (MIL-connector type) CPM2C-24EDT1M
- Input points: 16, DC input
- Output points: 8



- Transistor Output (Sink) I/O Unit (Connector type) CPM2C-32EDTC

- Transistor Output (Source) I/O Unit (Connector type) CPM2C-32EDT1C

- Transistor Output (Sink) I/O Unit (MIL-connector type) CPM2C-32EDTM

- Transistor Output (Source) I/O Unit (MIL-connector type) CPM2C-32EDT1M
- Input points: 16, DC input
- Output points: 16

Input Expansion I/O Units



- (Connector type) CPM2C-8EDC
- (MIL-connector type) CPM2C-8EDM
- Input points: 8, DC input

CPM2C-8EDC



- (Connector type) CPM2C-16EDC
- (MIL-connector type) CPM2C-16EDM
- Input points: 16, DC input

CPM2C-16EDC

Output Expansion I/O Units



- Relay Output I/O Unit (Terminal-block type) CPM2C-8ER
- Output points: 8



- Transistor Output (Sink) I/O Unit (Connector type) CPM2C-8ETC
- Transistor Output (Source) I/O Unit (Connector type) CPM2C-8ET1C

- Transistor Output (Sink) I/O Unit (MIL-connector type) CPM2C-8ETM

- Transistor Output (Source) I/O Unit (MIL-connector type) CPM2C-8ET1M
- Output points: 8



- Transistor Output (Sink) I/O Unit (Connector type) CPM2C-16ETC
- Transistor Output (Source) I/O Unit (Connector type) CPM2C-16ET1C

- Transistor Output (Sink) I/O Unit (MIL-connector type) CPM2C-16ETM

- Transistor Output (Source) I/O Unit (MIL-connector type) CPM2C-16ET1M
- Output points: 16

**Specifications**

**General**

Item	CPU Unit Specification					
	CPU Units with 10 I/O points (relay outputs)	CPU Units with 10 I/O points (transistor outputs)	CPU Units with 20 I/O points (relay outputs)	CPU Units with 20 I/O points (transistor outputs)	CPU Units with 32 I/O points (transistor outputs)	CPM2C-S CPU Unit with 10 I/O points (transistor outputs)
Supply voltage	24 V DC					
Operating voltage range	20.4 to 26.4 V DC					
Power consumption (Add Expansion Unit consumption from following tables.)	4 W	3 W	4 W	3 W	3 W	3 W
Inrush current	25 A max.					
Insulation resistance	20 MΩ min. (at 500 V DC) between isolated circuits					
Dielectric strength	2,300 V AC for 1 min (between isolated circuits)					
Noise immunity	Conforms to IEC61000-4-4, 2 kV (power lines)					
Vibration resistance	Conforming to IEC 60068-2-6, JIS C0040: 10 to 57 Hz, 0.075-mm amplitude, 57 to 150 Hz, acceleration: 9.8 m/s <sup>2</sup> in X, Y, and Z directions for 80 minutes each (Time coefficient; 8 minutes × coefficient factor 10 = total time 80 minutes)					
Shock resistance	Conforming to IEC 60068-2-27, JIS C0041: 147 m/s <sup>2</sup> three times each in X, Y, and Z directions					
Ambient temperature	Operating: 0° to 55° C Storage: -20° to 75° C (except for the battery)					
Humidity	10% to 90% (with no condensation)					
Atmosphere	Must be free from corrosive gas					
I/O interface	Terminal block	Connector	Terminal block	Connector		
Power interrupt time	2 ms min.					
Weight	200 g max.	200 g max.	250 g max.	200 g max.	200 g max.	160 g max.
	Expansion I/O Unit with 10 I/O points (relay outputs)				200 g max.	
	Expansion I/O Unit with 20 I/O points (relay outputs)				200 g max.	
	Expansion I/O Units with 24 I/O points (transistor outputs)				200 g max.	
	Expansion I/O Unit with 32 I/O points (transistor outputs)				200 g max.	
	Expansion I/O Unit with 8 input points				150 g max.	
	Expansion I/O Unit with 16 input points				150 g max.	
	Expansion I/O Units with 8 output points (transistor outputs)				150 g max.	
	Expansion I/O Units with 16 output points (transistor outputs)				150 g max.	
	Expansion I/O Unit with 8 output points (relay outputs)				200 g max.	
	Simple Communications Unit				150 g max.	
	Peripheral/RS232C Adapter Unit				150 g max.	
	RS422/RS232C Adapter Unit				150 g max.	
	AC Power Supply Unit				250 g max.	
	Analog I/O Unit				200 g max.	
Temperature Sensor Unit				200 g max.		
CompoBus/S I/O Link Unit				150 g max.		

**CPM2C Power Consumption**

Use the following power consumption tables to calculate the total power capacity required when using a CPM2C PLC. The rated output for the CPM2C-PA201 AC Power Supply Unit is 15 W. Any surplus power not required for the PLC directly can be used as service power supply for sensors and other devices.

CPU Unit	Power consumption (W)
CPM2C-10C(1)DR-D	4
CPM2C-20C(1)DR-D	4
CPM2C-S1□0C-DRT1	3
CPM2C-S1□0C	3
CPM2C-10C(1)DT(1)□-D	3
CPM2C-20C(1)DT(1)□-D	3
CPM2C-32C(1)DT(1)□-D	3

The power consumption of the CPU Unit includes power for the Programming Consoles and Adapter Units.

Add the following consumptions when using Expansion I/O Units.

Expansion I/O Unit	Power consumption (W)
CPM2C-10EDR	1
CPM2C-20EDR	2
CPM2C-24EDT(1)□	1
CPM2C-32EDT(1)□	1
CPM2C-MAD11	3.5
CPM2C-SRT21	1
CPM2C-TS001/002	1.5
CPM2C-8ED□/16ED□	1
CPM2C-8ER	2
CPM2C-8ET(1)□/16ET(1)□	1

CPM2C Characteristics

Item	CPU Unit Specification					
	CPU Units with 10 I/O points (relay outputs)	CPU Units with 10 I/O points (transistor outputs)	CPU Units with 20 I/O points (relay outputs)	CPU Units with 20 I/O points (transistor outputs)	CPU Units with 32 I/O points (transistor outputs)	CPM2C-S CPU Unit with 10 I/O points (transistor outputs) and CompoBus/S Master function
Control method	Stored program method					
I/O control method	Cyclic scan with direct output (Immediate refreshing can be performed with IORF(97).)					
Programming language	Ladder diagram					
Instruction length	1 step per instruction, 1 to 5 words per instruction					
Instructions	Basic instructions: 14 Special instructions: 105 instructions, 185 variations					
Execution time	Basic instructions: 0.64 μs (LD instruction) Special instructions: 7.8 μs (MOV instruction)					
Program capacity	4,096 words					
I/O capacity	CPU Unit only	10 points	20 points	20 points	32 points	10 points
	With Expansion I/O Units	170 points max.	180 points max.		192 points max.	362 points max. (106 local + 256 remote)
Input bits	IR 00000 to IR 00915 (Words not used for input bits can be used for work bits.)					
Output bits	IR 01000 to IR 01915 (Words not used for output bits can be used for work bits.)					
CompoBus/S input bits	---				128 inputs: IR 02000 to IR 02715	I/O bits not used for I/O be used as work bits.
CompoBus/S output bits	---				128 outputs: IR 03000 to IR 03715	
Work bits	928 bits: IR 02000 to IR 04915 (Words IR 020 to IR 049) and IR 20000 to IR 22715 (Words IR 200 to IR 227)				672 bits: IR 02800 to IR 02915 (Words IR 028 to IR 029), IR 03800 to IR 04915 (Words IR 038 to IR 049) and IR 20000 to IR 22715 (Words IR 200 to IR 227)	
Special bits (SR area)	448 bits: SR 22800 to SR 25515 (Words SR 228 to SR 255)					
Temporary bits (TR area)	8 bits (TR0 to TR7)					
Holding bits (HR area)	320 bits: HR 0000 to HR 1915 (Words HR 00 to HR 19)					
Auxiliary bits (AR area)	384 bits: AR 0000 to AR 2315 (Words AR 00 to AR 23)					
Link bits (LR area)	256 bits: LR 0000 to LR 1515 (Words LR 00 to LR 15)					
Timers/Counters	256 timers/counters (TIM/CNT 000 to TIM/CNT 255) 1-ms timers: TMHH(—) 10-ms timers: TIMH(15) 100-ms timers: TIM 1-s/10-s timers: TIML(—) Decrementing counters: CNT Reversible counters: CNTR(12)					
Data memory	Read/Write: 2,048 words (DM 0000 to DM 2047)* Read-only: 456 words (DM 6144 to DM 6599) PC Setup: 56 words (DM 6600 to DM 6655) *The Error Log is contained in DM 2000 to DM 2021.					
CompoBus/S master functions	---				Connects to up to 32 slaves with up to 256 I/O link points	
DeviceNet slave functions	---				DeviceNet remote I/O link (DRT model only) Up to 1,024 I/O link points Explicit messages Read/write of specified areas from PLC with Master Unit	
Basic interrupts	Interrupt processing	2 interrupts	2 interrupts	4 interrupts	4 interrupts	4 interrupts
	Interval timer interrupts	1 (Scheduled Interrupt Mode or Single Interrupt Mode)				
High-speed counter	High-speed counter	One high-speed counter: 20 kHz single-phase or 5 kHz two-phase (linear count method) Counter interrupt: 1 (set value comparison or set-value range comparison)				
High-speed counter	Interrupt inputs (Counter mode)	2 inputs	2 inputs	4 inputs	4 inputs	4 inputs
	Counter interrupts	2 inputs				
Pulse output	Counter mode	2 inputs				
	Interrupt mode	2 inputs				
Synchronized pulse control	Counter mode	2 inputs				
	Interrupt mode	2 inputs				
Quick-response inputs	Counter mode	2 inputs				
	Interrupt mode	2 inputs				
Input time constant (ON response time = OFF response time)	Counter mode	2 inputs				
	Interrupt mode	2 inputs				
Clock function	Shows the year, month, day of the week, day, hour, minute, and second. (Battery backup)					

Item	CPU Unit Specification					
	CPU Units with 10 I/O points (relay outputs)	CPU Units with 10 I/O points (transistor outputs)	CPU Units with 20 I/O points (relay outputs)	CPU Units with 20 I/O points (transistor outputs)	CPU Units with 32 I/O points (transistor outputs)	CPM2C-S CPU Unit with 10 I/O points (transistor outputs) and CompoBus/S Master function
Communications functions	Peripheral port: Supports Host Link, peripheral bus, no-protocol, or Programming Console connections. RS-232C port: Supports Host Link, no-protocol, 1:1 Slave Unit Link, 1:1 Master Unit Link, or 1:1 NT Link connections. A CPM2C-CN111, CS1W-CN114, or CS1W-CN118 Connecting Cable, or an Interface Unit (CPM2C-CIF01-V1 or CPM2C-CIF11) is required to connect to the CPM2C's communications port.					
Memory protection	HR area, AR area, program contents, read/write DM area contents, and counter values are maintained during power interruptions.					
Memory backup	Flash memory: Program, read-only DM area, and PC Setup Memory backup: The read/write DM area, HR area, AR area, and counter values are backed up. With CPU Units that are equipped with a clock, the battery will backup memory for 2 years at 25° C. With CPU Units that are not equipped with a clock, if a battery is not installed, the internal capacitor will backup memory for 10 days at 25° C. If a battery (optional CPM2C-BAT01 Battery) is installed, it will backup memory for 5 years at 25° C.					
Self-diagnostic functions	CPU Unit failure (watchdog timer), I/O bus error, battery error, and memory failure					
Program checks	No END instruction, programming errors (checked when operation is started)					

**CPM2C I/O Specifications**

**1. CPU Unit Input Specifications**

Item	Specifications			Circuit configuration
	Units with 10 I/O points	Units with 20 I/O points	Units with 32 I/O points	
Input voltage	24 V DC $+10\%$ / $-15\%$			<p>Input numbers: 00000 to 00001</p>
Input impedance	IN00000 to IN00001: 2.7 kΩ IN00002 to IN00004: 3.9 kΩ IN00005: 4.7 kΩ	IN00000 to IN00001: 2.7 kΩ IN00002 to IN00006: 3.9 kΩ IN00007 and up: 4.7 kΩ	IN00000 to IN00001: 2.7 kΩ IN00002 to IN00006: 3.9 kΩ IN00007: 4.7 kΩ IN00100 to IN00107: 4.7 kΩ	
Input current	IN00000 to IN00001: 8 mA IN00002 to IN00004: 6 mA IN00005: 5 mA	IN00000 to IN00001: 8 mA IN00002 to IN00006: 6 mA IN00007 and up: 5 mA	IN00000 to IN00001: 8 mA IN00002 to IN00006: 6 mA IN00007: 5 mA IN00100 to IN00107: 5 mA	
ON voltage/current	IN00000 to IN00001: 17 V DC min., 5 mA IN00002 and up: 14.4 V DC min., 3.5 mA			
OFF voltage/current	5.0 V DC max., 1.1 mA			
ON delay	1 to 80 ms max. Default: 10 ms (See note.)			
OFF delay	1 to 80 ms max. Default: 10 ms (See note.)			
				<p>Units with 10 I/O points: 00002 to 00004 Units with 20/32 I/O points: 00002 to 00006</p>
				<p>Units with 10 I/O points: 00005 Units with 20 I/O points: 00007 to 00011 Units with 32 I/O points: 00007 to 00011, 00100 to 00107</p>

**Note:** The input time constant can be set to 1, 2, 3, 5, 10, 20, 40, or 80 ms in the PC Setup.

**High-speed Counter Inputs**

The following CPU Unit input bits can be used as high-speed counter inputs. The maximum count frequency is 5 kHz in differential phase mode and 20 kHz in the other modes.

Input	Function			
	Differential phase mode	Pulse plus direction input mode	Up/down input mode	Increment mode
IN00000	A-phase pulse input	Pulse input	Increment pulse input	Increment pulse input
IN00001	B-phase pulse input	Direction input	Decrement pulse input	Normal input
IN00002	Z-phase pulse input or hardware reset input (IN00002 can be used as a normal input when it is not used as a high-speed counter input.)			

**Interrupt Inputs**

CPM2C PCs have inputs that can be used as interrupt inputs (interrupt input mode or counter mode) and quick-response inputs. The minimum pulse width for these inputs is 50 μs.  
In CPU Units with 10 I/O points, inputs IN00003 and IN00004 can be used as interrupt inputs. In CPU Units with 20 or 32 I/O points, inputs IN00003 through IN00006 can be used as interrupt inputs.

## 2. Expansion I/O Unit Input Specifications

Item	Specification
Input voltage	24 V DC $+10\%/_{-15\%}$
Input impedance	4.7 k $\Omega$
Input current	5 mA
ON voltage/current	14.4 V DC min., 3.5 mA
OFF voltage/current	5.0 V DC max., 1.1 mA
ON delay	1 to 80 ms max. Default: 10 ms (See note.)
OFF delay	1 to 80 ms max. Default: 10 ms (See note.)
Circuit configuration	

**Note:** The input time constant can be set to 1, 2, 3, 5, 10, 20, 40, or 80 ms in the PC Setup.

## 3. CPM2C Output Specifications (CPU Units and Expansion I/O Units)

### Relay Output

Item	Specification
Max. switching capacity	2 A, 250 V AC ( $\cos\phi = 1$ ) 2 A, 24 V DC (4 A/common)
Min. switching capacity	10 mA, 5 V DC
Service life of relay	Electrical:150,000 operations (24- V DC resistive load) 100,000 operations (240- V AC inductive load, $\cos\phi = 0.4$ ) Mechanical:20,000,000 operations
ON delay	15 ms max.
OFF delay	15 ms max.
Circuit configuration	

### Transistor Outputs (Sinking or Sourcing) for CPU Units and Expansion I/O Units

Item	Specification
Max. switching capacity	CPU Units with 10 or 20 I/O Points 01000 to 01007: 40 mA at 4.5 V DC to 300 mA at 20.4 V DC, 300 mA (20.4 to 26.4 V) CPU Units with 32 I/O Points 01000 to 01007: 40 mA at 4.5 V DC to 300 mA at 20.4 V DC, 300 mA (20.4 to 26.4 V) 01100 to 01107: 40 mA at 4.5 V DC to 100 mA at 20.4 V DC, 100 mA (20.4 to 26.4 V) (See note.) Expansion I/O Units 01□00 to 01□07: 40 mA at 4.5 V DC to 300 mA at 20.4 V DC, 300 mA (20.4 to 26.4 V) 01□08 to 01□15: 40 mA at 4.5 V DC to 100 mA at 20.4 V DC, 100 mA (20.4 to 26.4 V) (See note.)
Min. switching capacity	0.5 mA
Max. inrush current	0.9 A for 10 ms (charging and discharging waveform)
Leakage current	0.1 mA max.
Residual voltage	0.8 V max.
ON delay	OUT01000 and OUT01001:20 $\mu$ s max. OUT01002 and up:0.1 ms max.
OFF delay	OUT01000 and OUT01001:40 $\mu$ s max. for 4.5 to 26.5 V, 10 to 300 mA 0.1 ms max. for 4.5 to 30 V, 0.5 to 10 mA OUT01002 and up:1 ms max.
Fuse	1 fuse for each 2 outputs (The fuse cannot be replaced by the user.)

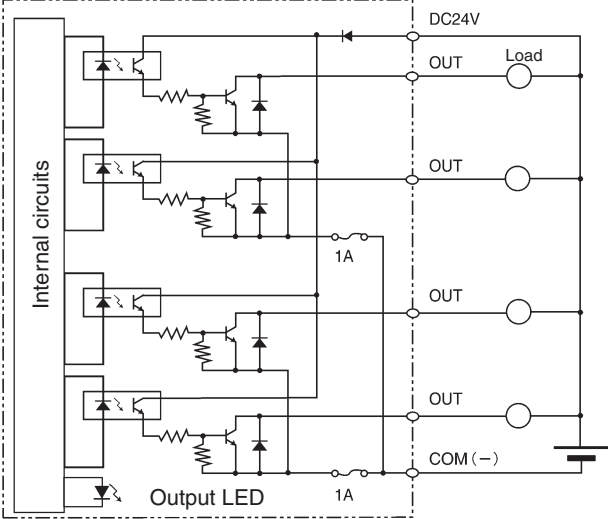
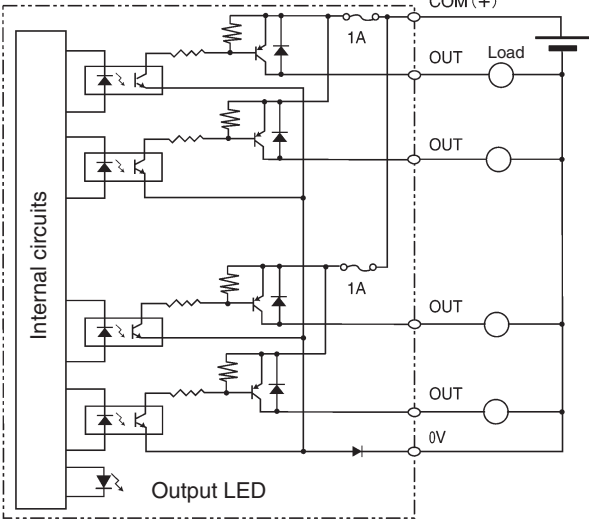
Item	Specification
Circuit configuration	<p style="text-align: center;"><b>Sinking Outputs</b></p>  <p style="text-align: center;"><b>Sourcing Outputs</b></p> 

**Note:** Connect dummy resistance as required and maintain the load current between 10 and 150 mA when using 01000 and 01001 for pulse outputs. The ON/OFF response time will increase if the load current is below 10 mA, preventing outputting high-speed pulses. The transistors will heat if the output current is greater than 150 mA, possibly destroying the elements.

CPM2C-S1□0C

# CPU Units with CompoBus/S Master

## Ultra-compact CPM2C CPU unit with CompoBus/S master offering high speed remote I/O communication.

- The compact design makes this unit ideal for local control applications.  
At 40 x 90 x 65 mm (W x H x D) with 10 I/O points and CompoBus/S master offering versatile expandability it is possible to fulfill control systems needs.
- A large number of expansion I/O points reduces system construction cost.  
Up to three Expansion Up to three expansion terminals can be connected to the CPU unit. Furthermore, CompoBus/S remote I/O terminals can be used for expansion I/O points. Not only in-panel wiring but also external wiring is simplified. The miniaturization of the control panel reduces cable, terminal block, and wiring cost.
- Easy system designing, modification, and expansion by CompoBus/S remote I/O terminals.  
With this high-speed communication bus and no complicated wiring they can be used as expansion terminal blocks with minimal modifications to the system layout as long as room for expansion is reserved at the first designing stage.
- A calendar/clock ensures timed machine control, including data collection and error logs with date and time stamps.

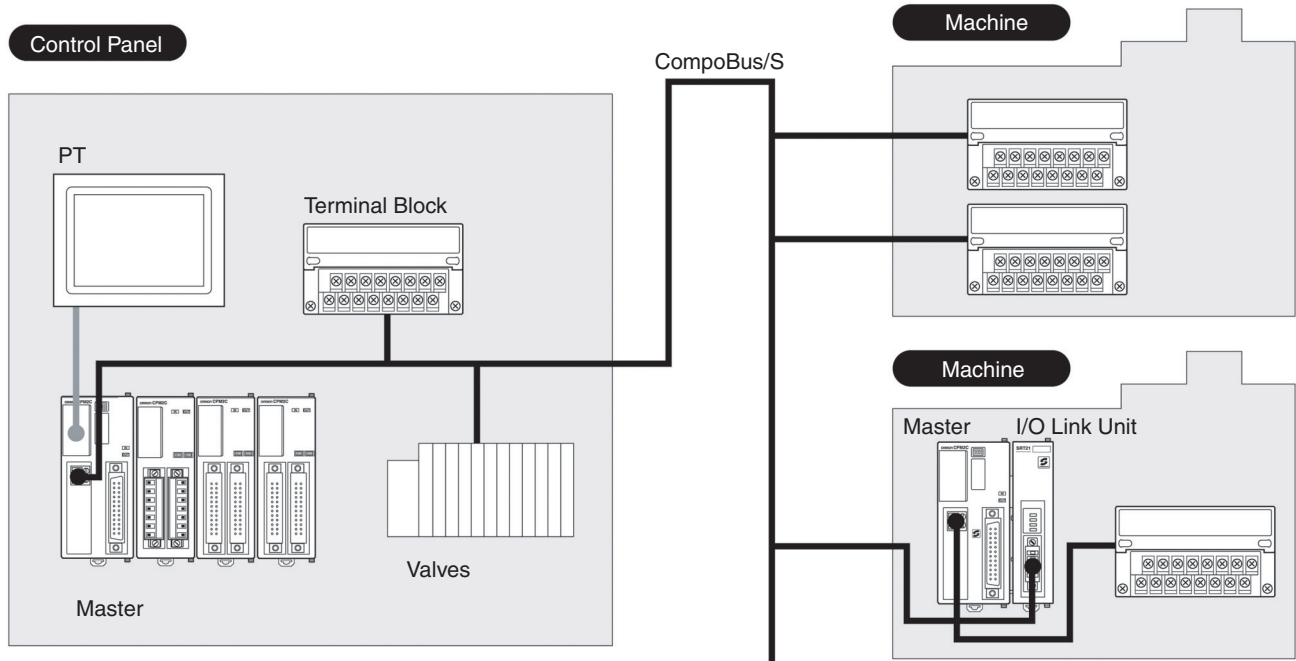

Ordering Information

Unit	Inputs	Outputs	Clock	Model	
10 points (6 inputs/4 outputs)	Connector model	6 points at 24 V DC	4 transistor sinking outputs	Yes	CPM2C-S100C
			4 transistor sourcing outputs	Yes	CPM2C-S110C

Specifications

General Specifications

Item	Specification	
Control method	Stored program method	
I/O control method	Cyclic scan method (Immediate refreshing can be performed with IORF(97).)	
Programming language	Ladder diagram	
Instruction length	1 step per instruction 1 to 5 words per instruction	
Instructions	Basic instructions	14
	Special instructions	105 instructions, 185 variations
Execution time	Basic instructions	0.64 μs (LD instruction)
	Special instructions	7.8 μs (MOV instruction)
Program capacity	4,096 words	
Max. I/O capacity	CPU Unit only: 10 points Expansion I/O Unit: 96 points (32-point Expansion I/O Unit x 3) (Up to 3 Expansion Units can be connected.) CompoBus/S: 256 points (362 points in total)	
Input bits	IR 00000 to IR 00915 (Bits not used for input bits can be used for work bits.)	
Output bits	IR 01000 to IR 01915 (Bits not used for output bits can be used for work bits.)	
CompoBus/S input bits	128 bits: IR 02000 to IR 02715 (words IR 020 to IR 027)	
CompoBus/S output bits	128 bits: IR 03000 to IR 03715 (words IR 030 to IR 037)	
Work bits	672 bits: IR 02800 to IR 02915 (words IR 028 to IR 029) IR 03800 to IR 03915 (words IR 038 to IR 039) IR 04000 to IR 04915 (words IR 040 to IR 049) IR 20000 to IR 22715 (words IR 200 to IR 227)	
Special bits (SR area)	440 bits: SR 22800 to SR 25507 (words SR 228 to SR 255)	
Temporary bits (TR area)	8 bits: (TR 0 to TR 7)	
Holding bits (HR area)	320 bits: HR 0000 to HR 1915 (words HR 00 to HR 19)	
Auxiliary bits (AR area)	384 bits: AR 0000 to AR 2315 (words AR 00 to AR 23) These include CompoBus/S slave status flags (words AR 04 to AR 07).	
Link bits (LR area)	256 points: LR 0000 to LR 1515 (words LR 00 to LR 15)	
Timers/Counters	256 timers/counters: TIM/CNT 000 to TIM/CNT 255 1-ms timers: TMHH (-) 10-ms timers: TIMH (15) 100-ms timers: TIM 1-s/10-s timers: TIML (-) Decrementing counters: CNT Reversible counters: CNTR (12)	
Data memory	Read/Write	2,048 words (DM 0000 to DM 2047) The Error Log is contained in DM 2000 to DM 2021.
	Read only	456 words (DM 6144 to DM 6599)
	PC Setup	56 words (DM 6600 to DM 6655)
Basic interrupt functions	Interrupt inputs	2 interrupts (Used for both counter mode interrupts inputs and quick-response inputs.)
	Scheduled interrupts	1 interrupt
High-speed counter functions	High-speed counters	1 counter (single phase at 20 kHz or 2 phases at 5 kHz)
	Counter interrupts	1 interrupt (set value comparison or set-value range comparison)
	Interrupt inputs (counter mode)	2 interrupts (Used for both external interrupts inputs and quick-response inputs.)
	Count-up interrupts	2 interrupts (Used for both external interrupts inputs and quick-response inputs.)
Quick-response inputs	2 points (Used for both external interrupts inputs and counter mode interrupt inputs.) Min. input pulse width: 50 μs max.	
Pulse output	2 points with no acceleration/deceleration, 10 Hz to 10 kHz each, and no direction control: 1 point with trapezoid acceleration/deceleration, 10 Hz to 10 kHz with direction control: or 2 points with variable duty-ratio outputs	
Synchronized pulse control	1 point	
Input time constant (ON response time = OFF response time)	Can be set for CPU Unit inputs and Expansion Unit inputs only (1, 2, 3, 5, 10, 20, 40, or 80 ms)	
Clock	Equipped with clock (built-in RTC)	
Communications functions	Peripheral port: Supports Host Link, peripheral bus, no-protocol communications, and Programming Console connections. RS-232C port: Supports Host Link, no-protocol communications, 1-to-1 Link, or 1-to-1 NT Link connections.	
Power failure backup function	Data in HR, AR, Counter (CNT), and Data Memory (DM) areas is held.	
Memory backup	Non-volatile (flash) memory: Program, read-only DM area, and PC Setup Memory backup (lithium battery: 2 years lifetime): DM area, HR area, AR area, and counter values	
Self-diagnostic functions	CPU error (watchdog timer), memory errors, communications errors, setting errors, battery errors, and expansion I/O bus errors	
Program check	No END instruction, programming errors (checked when operation is started)	

Item		Specification
Programming devices	Programming Console	C200H-PRO27, CQM1-PRO01, or CQM1H-PRO01
	CX-One	Windows 2000 / XP

**Note:** Connecting Cable (CPM2C-CN111, CS1W-CN114, or CS1W-CN118) is required to connect to the communications peripheral /RS-232C port.

**Communications Specifications**

Communications method		Special CompoBus/S protocol
Coding method		Manchester coding
Connection form		Combination of multi-drop method and T-branch connections (see note 1)
Baud rate		High-speed Communications Mode: 750 kbps Long-distance Communications Mode: 93.75 kbps (see note 2)
Communications cycle time	High-speed Communications Mode	0.5 ms (with 8 input and 8 output slaves connected)
		0.8 ms (with 16 input and 16 output slaves connected)
	Long-distance Communications Mode	4.0 ms (with 8 input and 8 output slaves connected) 6.0 ms (with 16 input and 16 output slaves connected)
Communications media		2-conductor cable (VCTF 0.75 x 2), 4-conductor cable (VCTF 0.75 x 4), or Special Flat Cable
Communications distance	High-speed Communications Mode	2-conductor VCTF cable: Main line length:100 m max. Branch line length:3 m max. Total branch line length:50 m max. Special Flat Cable, 4-conductor VCTF cable: Main line length:30 m max. Branch line length:3 m max. Total branch line length:30 m max. (When Special Flat Cable is used to connect fewer than 16 Slaves, the main line can be up to 100 m long and the total branch line length can be up to 50 m.)
	Long-distance Communications Mode	2-conductor VCTF cable: Main line length:500 m max. Branch line length:6 m max. Total branch line length:120 m max. Special Flat Cable, 4-conductor VCTF cable: Variable branch wiring (total cable length 200 m max.) (There are no limits on the branching format or main, branch, or total line lengths. The terminator must be connected to the point in the system farthest from the master.)
Maximum number of nodes		32
Error control checks		Manchester code check, frame length check, and parity check

- Note:** 1. A terminator must be connected to the point in the system farthest from the Master.  
2. The baud rate is switched using DM settings (default setting is 750 kbps).

**Dimensions**

**Note:** All units are in millimeters unless otherwise indicated.

**CPM2C-S100C  
CPM2C-S110C**

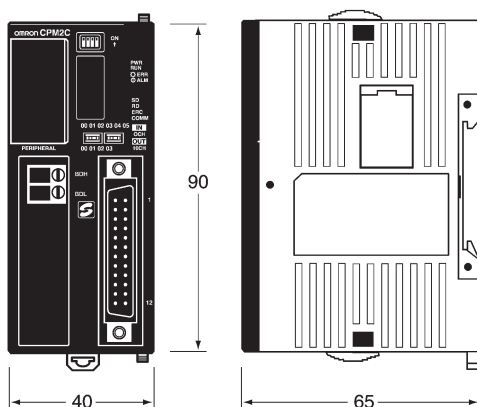

**Note:** Refer to *CPM2C-S Programmable Controller Operation Manual (W377)* for detailed specifications.

CPM2C-S1□0C-DRT

# Programmable Slave PLC

## Multi-functional programmable slave for distributed control

A part of an installation consisting of sensors, actuators and control is handled as one DeviceNet slave.

The distribution of device control enables the production of standard units with standardized programs and decreasing the load on the system master PLC. Conventional distributed I/O control networks do not allow I/O checks or operation checks until all devices on the networks are assembled and connected. Programmable slaves, however, allow I/O and operation checks

on any distributed unit independently.

- **DeviceNet slave functionality**  
Supports multi-word I/O links and explicit message communication, making it possible for the master to control the data of all the slaves on the network. Data that does not need immediate transmission, such as log data, can be transmitted in blocks using explicit message communication.
- **CompoBus/S master functionality**  
Connects to remote signal lights, pushbutton switches, terminal blocks, and pneumatic valves from other companies over VCTF or easy-to-branch flat cable.
- **RS-232C Communications**  
Barcodereaders and PTs can be connected to serial port. The data then will be processed locally and thus reduces the load on the central controlling PLC.
- **Expansion unit (Up to three units)**  
A wide variety of different expansion units is available to fit the application needs.

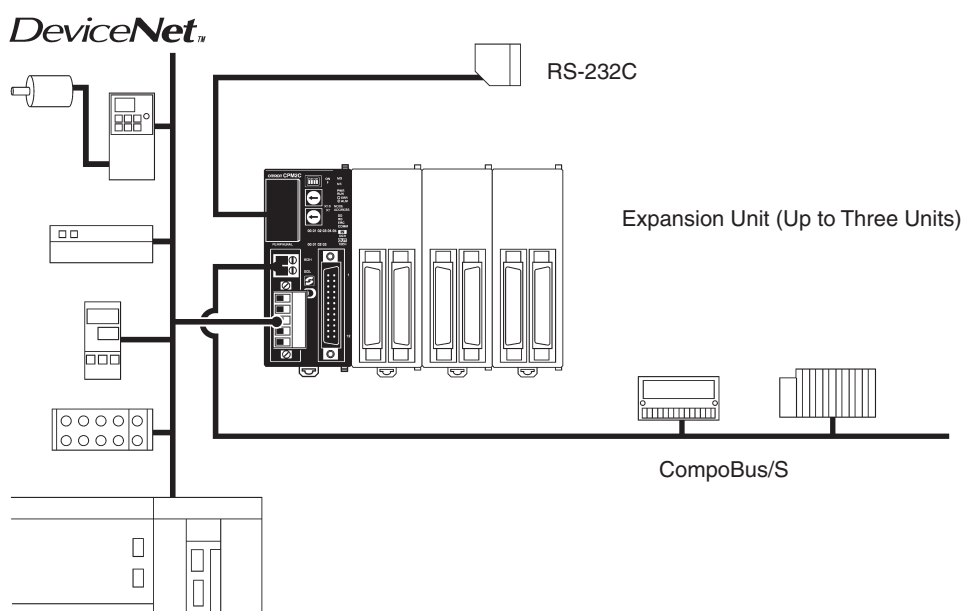

## Ordering Information

Unit		Inputs	Outputs	Clock	Model
10 points (6 inputs/4 outputs)	Connector model	6 points at 24 V DC	4 transistor sinking outputs	Yes	CPM2C-S100C-DRT
			4 transistor sourcing outputs	Yes	CPM2C-S110C-DRT

## Specifications

### General Specifications

Item	Specification	
Control method	Stored program method	
I/O control method	Cyclic scan method (Immediate refreshing can be performed with IORF(97).)	
Programming language	Ladder diagram	
Instruction length	1 step per instruction 1 to 5 words per instruction	
Instructions	Basic instructions	14
	Special instructions	105 instructions, 185 variations
Execution time	Basic instructions	0.64 $\mu$ s (LD instruction)
	Special instructions	7.8 $\mu$ s (MOV instruction)
Program capacity	4,096 words	
Max. I/O capacity	CPU Unit only: 10 points Expansion I/O Unit: 96 points (32-point Expansion I/O Unit x 3) (Up to 3 Expansion Units can be connected.) CompoBus/S: 256 points (362 points in total)	
Input bits	IR 00000 to IR 00915 (Bits not used for input bits can be used for work bits.)	
Output bits	IR 01000 to IR 01915 (Bits not used for output bits can be used for work bits.)	
CompoBus/S input bits	128 bits: IR 02000 to IR 02715 (words IR 020 to IR 027)	
CompoBus/S output bits	128 bits: IR 03000 to IR 03715 (words IR 030 to IR 037)	
Work bits	672 bits: IR 02800 to IR 02915 (words IR 028 to IR 029) IR 03800 to IR 03915 (words IR 038 to IR 039) IR 04000 to IR 04915 (words IR 040 to IR 049) IR 20000 to IR 22715 (words IR 200 to IR 227)	
Special bits (SR area)	440 bits: SR 22800 to SR 25507 (words SR 228 to SR 255)	
Temporary bits (TR area)	8 bits: (TR 0 to TR 7)	
Holding bits (HR area)	320 bits: HR 0000 to HR 1915 (words HR 00 to HR 19)	
Auxiliary bits (AR area)	384 bits: AR 0000 to AR 2315 (words AR 00 to AR 23) These include CompoBus/S slave status flags (words AR 04 to AR 07).	
Link bits (LR area)	256 points: LR 0000 to LR 1515 (words LR 00 to LR 15)	
Timers/Counters	256 timers/counters: TIM/CNT 000 to TIM/CNT 255 1-ms timers: TMHH (--) 10-ms timers: TIMH (15) 100-ms timers: TIM 1-s/10-s timers: TIML (--) Decrementing counters: CNT Reversible counters: CNTR (12)	
Data memory	Read/Write	2,048 words (DM 0000 to DM 2047) The Error Log is contained in DM 2000 to DM 2021.
	Read only	456 words (DM 6144 to DM 6599)
	PC Setup	56 words (DM 6600 to DM 6655)
DeviceNet slave functions	DeviceNet Remote I/O Link No. of I/O Link points: 1,024 max. Explicit message communications Any PC data area can be accessed from the master.	
Basic interrupt functions	Interrupt inputs	2 interrupts (Used for both counter mode interrupts inputs and quick-response inputs.)
	Scheduled interrupts	1 interrupt

Item		Specification
High-speed counter functions	High-speed counters	1 counter (single phase at 20 kHz or 2 phases at 5 kHz)
	Counter interrupts	1 interrupt (set value comparison or set-value range comparison)
	Interrupt inputs (counter mode)	2 interrupts (Used for both external interrupts inputs and quick-response inputs.)
	Count-up interrupts	2 interrupts (Used for both external interrupts inputs and quick-response inputs.)
Quick-response inputs		2 points (Used for both external interrupts inputs and counter mode interrupt inputs.) Min. input pulse width: 50 μs max.
Pulse output		2 points with no acceleration/deceleration, 10 Hz to 10 kHz each, and no direction control: 1 point with trapezoid acceleration/deceleration, 10 Hz and 10 kHz with no direction control: or 2 points with variable duty-ratio outputs
Synchronized pulse control		1 point
Input time constant (ON response time = OFF response time)		Can be set for CPU Unit inputs and Expansion Unit inputs only (1, 2, 3, 5, 10, 20, 40, or 80 ms)
Clock		Equipped with clock (built-in RTC)
Communications functions		Peripheral port: Supports Host Link, peripheral bus, no-protocol communications, and Programming Console connections. RS-232C port: Supports Host Link, no-protocol communications, 1-to-1 Link, or 1-to-1 NT Link connections.
Power failure backup function		Data in HR, AR, Counter (CNT), and Data Memory (DM) areas is held.
Memory backup		Non-volatile (flash) memory: Program, read-only DM area, and PC Setup Memory backup (lithium battery: 2 years lifetime): DM area, HR area, AR area, and counter values
Self-diagnostic functions		CPU error (watchdog timer), memory errors, communications errors, setting errors, battery errors, and expansion I/O bus errors
Program check		No END instruction, programming errors (checked when operation is started)
Programming devices	Programming Console	C200H-PRO27, CQM1-PRO01, or CQM1H-PRO01
	CX-One	Windows 2000 / XP

**Note:** Connecting Cable (CPM2C-CN111, CS1W-CN114, or CS1W-CN118) is required to connect to the communications peripheral /RS-232C port.

## Communications Specifications

### DeviceNet

Communications protocol		DeviceNet
Connection form		Combination of multi-drop and T-branch connections (see note 1)
Baud rate		500, 250, or 125 kbps (switchable)
Communications media		Special 5-conductor cable (2 signal lines, 2 power supply lines, and 1 shield line)
Communications distance	Baud rate	500 kbps: Max. network length (see note 2):100 m max. (see note 3) Main line length:6 m max. Total branch line length:39 m max.
		250 kbps: Max. network length (see note 2):250 m max. (see note 3) Main line length:6 m max. Total branch line length:78 m max.
		125 kbps: Max. network length (see note 2):500 m max. (see note 3) Main line length:6 m max. Total branch line length:156 m max.
Max. number of connecting nodes		64 (63 slaves and 1 master)
Error control checks		CRC error, node address duplication check, and scan list verification

- Note:**
1. A terminator must be connected to both ends of the trunk line.
  2. The maximum network length is the length of the trunk line.
  3. When Thin Cable is used for the main line, the main line must be 100 m or less in length.

CompoBus/S

Communications method		Special CompoBus/S protocol
Coding method		Manchester coding
Connection form		Combination of multi-drop method and T-branch connections (see note 1)
Baud rate		High-speed Communications Mode: 750 kbps Long-distance Communications Mode: 93.75 kbps (see note 2)
Communications cycle time	High-speed Communications Mode	0.5 ms (with 8 input and 8 output slaves connected) 0.8 ms (with 16 input and 16 output slaves connected)
	Long-distance Communications Mode	4.0 ms (with 8 input and 8 output slaves connected) 6.0 ms (with 16 input and 16 output slaves connected)
Communications media		2-conductor cable (VCTF 0.75 x 2), 4-conductor cable (VCTF 0.75 x 4), or Special Flat Cable
Communications distance	High-speed Communications Mode	2-conductor VCTF cable: Main line length:100 m max. Branch line length:3 m max. Total branch line length:50 m max. Special Flat Cable, 4-conductor VCTF cable: Main line length:30 m max. Branch line length:3 m max. Total branch line length:30 m max. (When Special Flat Cable is used to connect fewer than 16 Slaves, the main line can be up to 100 m long and the total branch line length can be up to 50 m.)
	Long-distance Communications Mode	2-conductor VCTF cable: Main line length:500 m max. Branch line length:6 m max. Total branch line length:120 m max. Special Flat Cable, 4-conductor VCTF cable: Variable branch wiring (total cable length 200 m max.) (There are no limits on the branching format or main, branch, or total line lengths. The terminator must be connected to the point in the system farthest from the master.)
Maximum number of nodes		32
Error control checks		Manchester code check, frame length check, and parity check

- Note:** 1. A terminator must be connected to the point in the system farthest from the Master.  
2. The baud rate is switched using DM settings (default setting is 750 kbps).

Dimensions

**Note:** All units are in millimeters unless otherwise indicated.

CPM2C-S100C-DRT  
CPM2C-S110C-DRT

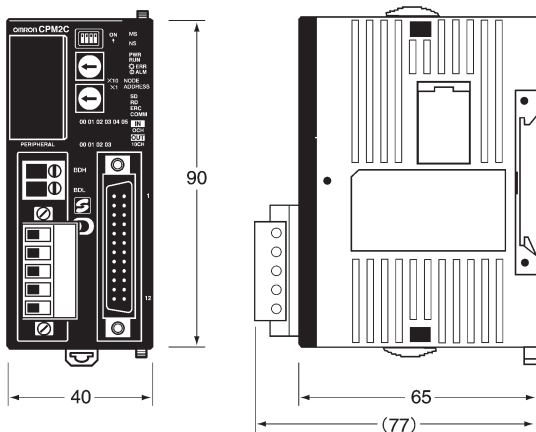

**Note:** Refer to *CPM2C-S Programmable Controller Operation Manual (W377)* for detailed specifications.

CPM2C-PA201

# AC Power Supply Unit

- The CPM2C-PA201 is a slim and compact AC Power Supply Unit of the same shape as the CPM2C's CPU Unit. It can be connected simply using the connecting cable (23 cm) provided. It can also be used for CPM1A and CPM2A CPU Units and as display power supply (wired by the user).

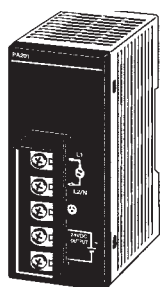

Service power supply for external devices such as sensors (24 V).

AC Power Supply Unit

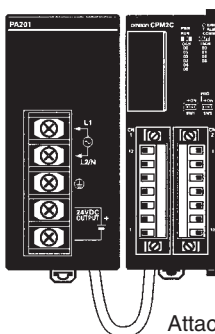

AC Power Supply Unit

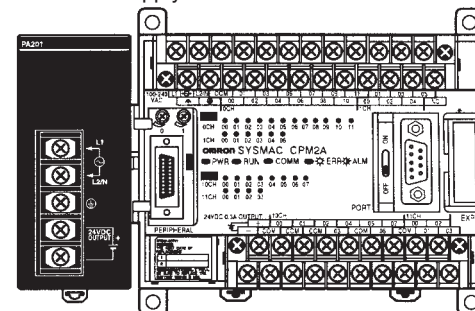

Attached connecting cable

## Specifications

Item	Specification		
Rated output	15 W		
Output voltage	24 V		
Output current	600 mA		
Efficiency	75% min. (at rated output)		
Input conditions	Rated voltage	100 to 240 V AC	
	Allowable voltage range	85 to 264 V AC	
	Frequency	47 to 63 Hz	
	Current	100 V	0.4 A
		200 V	0.2 A
	Leakage current	100 V	0.5 mA max. (at rated output)
		200 V	1 mA max. (at rated output)
Inrush current	100 V	15 A max. (at 25°C cold start)	
	200 V	30 A max. (at 25°C cold start)	
Output characteristics	Output voltage accuracy	10%~15% (including input, load, and temperature fluctuations)	
	Minimum output current	30 mA	
	Ripple noise voltage	2% (p-p) max.	
	Input fluctuation	0.75% max.	
	Load fluctuation	4% max.	
	Temperature fluctuation	0.05%/°C max.	
	Startup time	300 ms max. (at input voltage of 100 V AC or 200 V AC and the rated output)	
Output hold time	10 ms (at input voltage of 100 V AC or 200 V AC and the rated output)		
Overcurrent protection	Self-resetting, operates at 105% to 335% of the rated current, suspended and independent operation		
Overvoltage protection	None		
Ambient operating temperature	0° to 55°C		
Ambient storage temperature	-20° to 70°C (no condensation or icing)		
Ambient operating humidity	10% to 90% (no condensation)		
Dielectric strength	2,000 V for 1 min between all inputs and GR Leakage current: 10 mA 3,000 V for 1 min between all inputs and all outputs Leakage current: 10 mA 1,000 V for 1 min between all outputs and GR Leakage current: 10 mA		
Insulation resistance	100 MΩ min. at 500 V DC between all outputs and any input, and between all outputs and GR		
Vibration resistance	10 to 57 Hz, amplitude, 57 to 150 Hz, acceleration: 9.8 m/s <sup>2</sup> in X, Y, and Z directions for 80 minutes according (Time coefficient: 8 minutes × coefficient factor 10 = total time 80 min.)		
Shock resistance	147 m/s <sup>2</sup> 3 times each in X, Y, and Z directions		
Noise terminal voltage	FCC class A		
Weight	250 g max.		

CPM2C-MAD11

# Analog I/O Unit

- Up to four CPM2C-MAD11 Analog I/O Units can be connected to the CPM2C. Each Unit provides 2 analog inputs and 1 analog output, i.e., up to 8 analog inputs and 4 analog outputs can be supported by one CPM2C.
- Example Application: Packaging Machines



## Specifications

Item		Voltage I/O	Current I/O
Analog inputs	Number of inputs	2 (allocated 2 words)	
	Input signal ranges	0 to 5 V, 1 to 5 V, 0 to 10 V, -10 to 10 V	
	Maximum rated input	±15 V	
	External input impedance	1 MΩ min.	
	Resolution	1/6,000 (full scale)	
	Overall precision	25° C:±0.3% of full scale	25° C:±0.4% of full scale
		0 to 55° C:±0.6% of full scale	0 to 55° C:±0.8% of full scale
	Converted A/D data	Binary data (4-digit hexadecimal) -10 to 10 V: F448 to 0BB8 Hex full scale Other:0000 to 1770 Hex full scale	
	Averaging	Supported (set for each input with DIP switch)	
	Disconnected line detection	Supported	
Analog output	Number of outputs	1 (allocated 1 word)	
	Output signal ranges	1 to 5 V, 0 to 10 V, -10 to 10 V	
	External output allowed load resistance	1 kΩ min.	
	External output impedance	0.5 Ω max.	
	Resolution	1/6,000 (full scale)	
	Overall precision	25° C:±0.4% of full scale	---
		0 to 55° C:±0.8% of full scale	
D/A data setting	Binary data (4-digit hexadecimal) -10 to 10 V: F448 to 0BB8 Hex full scale Other:0000 to 1770 Hex full scale		
Conversion time	2 ms/point (6 ms/all analog I/O)		
Isolation method	Photocoupler isolation between analog I/O and internal circuits. (Individual analog I/O signals are not isolated.)		
Power consumption	3.5 W		
Weight	200 g max.		

CPM2C-TS001/-TS101

# Temperature Sensor Units

- Up to four CPM2C-TS001/TS101 Temperature Sensor Units can be connected to the CPM2C. Each Unit provides 2 input points for temperature sensors, including thermocouples or temperature resistance thermometers, i.e., up to 8 temperature sensors can be input to one CPM2C.
- Application Examples: Foodstuff Equipment and Packaging Machines



## Specifications

### General

Item	CPM2C-TS001	CPM2C-TS101
Temperature sensor	Thermocouple	Temperature resistance thermometer
Input types	K or J selectable (The same input type must be used for all inputs.)	Pt100, JPt100 selectable (The same input type must be used for all inputs.)
Number of inputs	2 (2 words allocated)	
Accuracy	$\pm 0.5\%$ or $\pm 2^\circ\text{C}$ of the stored value whichever is larger $\pm 1$ digit max. (see note)	$\pm 0.5\%$ or $\pm 1^\circ\text{C}$ of the stored value whichever is larger (see note) $\pm 1$ digit max.
Conversion cycle	250 ms/2 inputs	
Converted temperature data	Binary data (4-digit hexadecimal)	
Isolation method	Photocoupler isolation between input signals	
Power consumption	1.5 W	
Weight	200 g max.	

**Note:** Accuracy for K thermocouples at temperatures less than  $-100^\circ\text{C}$ :  $\pm 4^\circ\text{C} \pm 1$  digit max.

### Input Temperature Ranges for CPM2C-TS001

The input type is selected with a rotary switch. The ranges for each of the input types are shown in the following table.

Item	Range in $^\circ\text{C}$	Range in $^\circ\text{F}$
K	-200 to 1,300	-300 to 2,300
	0.0 to 500.0	0.0 to 900.0
J	-100 to 850	-100 to 1,500
	0.0 to 400.0	0.0 to 750.0

### Input Temperature Ranges for CPM2C-TS101

The input type is selected with a rotary switch. The ranges for each of the input types are shown in the following table.

Item	Range in $^\circ\text{C}$	Range in $^\circ\text{F}$
Pt100	-200.0 to 650.0	-300 to 1,200.0
JPt100	-200.0 to 650.0	-300 to 1,200.0

CPM2C-CIF21

# Simple Communications Unit

Easy initial settings enable data exchange between the CPM2C and components.

## System Configuration

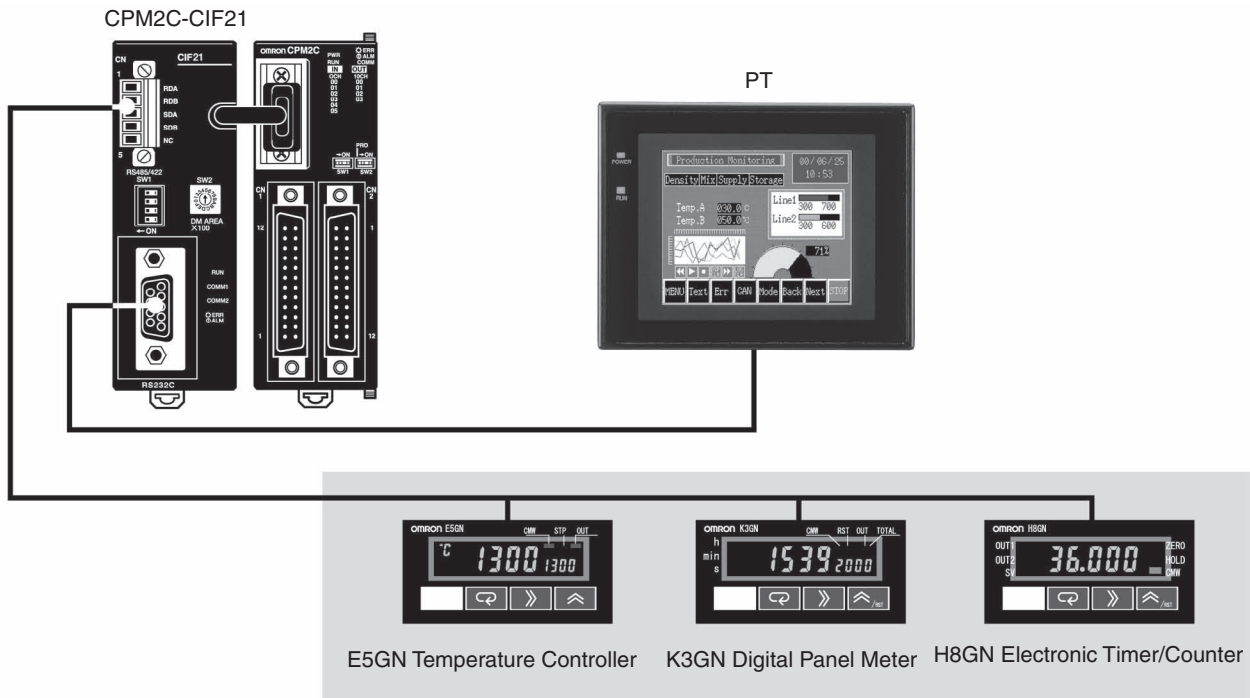

## Connectable Devices

A Wide Range of Devices Supporting CompoWay/F or SYSWAY Communications

Classification	Product	Model	SYSWAY		CompoWay/F	Remarks
			Yes	Segments		
Controllers	Temperature Controllers	E5GN	Yes	1	Yes	---
		E5CN	Yes	1	Yes	---
		E5EN	Yes	1	Yes	---
		E5AN	Yes	1	Yes	---
	Modular Temperature Controller	E5ZN	No	---	Yes	---
	Digital Controllers	E5CK	Yes	1	No	---
		E5EK	Yes	1	No	---
		E5AK	Yes	1	No	---
	Digital Controllers for control valves	E5EK	Yes	1	No	Valve system communications not supported.
		E5AK	Yes	1	No	---
	Digital Controller, basic type	E5CK-T	No	---	No	---
		E5EK-T	No	---	No	---
		E5AK-T	No	---	No	---
	Digital Controllers for control valves, programmable	E5EK-T	No	---	No	---
		E5AK-T	No	---	No	---
Temperature Controllers	E5EJ	Yes	1	No	---	
	E5AJ	Yes	1	No	---	
	Fuzzy Temperature Controller	E5AF	Yes	1	No	---
Timers	Electronic Timer/Counter	H8GN	No	---	Yes	---

Classification	Product	Model	SYSWAY	Segments	CompoWay/F	Remarks
Digital Panels	Digital Panel Meter	K3GN	No	---	Yes	---
	Process Meter	K3NX	Yes	2	Limited	Some commands cannot be used with some models (options). Only the CompoWay/F variable area can be read.
	Weighing Meter	K3NV	Yes	2	Limited	
	Frequency/Rate Meter	K3NR	Yes	2	Limited	
	Period Meter	K3NP	Yes	2	Limited	
	Up/Down Counter Meter	K3NC	Yes	2	Limited	
	Temperature Meter	K3NH	Yes	2	Limited	
	Intelligent Signal Processor	K3TS	Yes	2	No	SYSWAY communications only (See note 2.)

Limited: Connection possible for limited functions.

- Note:** 1. SYSWAY segment 1 and SYSWAY segment 2 can be combined.  
 2. When a K3TS is connected, connect the other components via SYSWAY as well.

### Component Parameters Supported for Communications

The communications protocol for components can be set in the CPM2C's DM Area to CompoWay/F or SYSWAY. The data that can be read and written depends on the protocol that is set.

#### CompoWay/F

Reading and writing is possible for all component data (except for some Digital Panel Meters). The amount of data that can be read/written in one operation per component is limited to 12 data items for reading and 12 data items for writing. Reading and writing is enabled by setting the address for each parameter in DM.

#### SYSWAY

Reading and writing is possible for the data shown in the following table.

Segment	Read/write	Item	Command group				
			1	2	3	4	5
1: Controllers	Read	Present temperature	Yes	Yes	Yes	Yes	Yes
		Status	Yes	Yes	Yes	Yes	Yes
		Temperature set value	Yes	Yes	Yes	Yes	Yes
		Alarm 1 set value			Yes	Yes	Yes
		Alarm 2 set value			Yes	Yes	Yes
		Proportional band				Yes	Yes
		Integral time				Yes	Yes
		Derivative time				Yes	Yes
		Heater current					Yes
		Heater current status					Yes
	Write	Temperature set value	Yes	Yes	Yes	Yes	Yes
		Operation command		Yes	Yes	Yes	Yes
		Alarm 1 set value			Yes	Yes	Yes
		Alarm 2 set value			Yes	Yes	Yes
		Proportional band				Yes	Yes
		Integral time				Yes	Yes
		Derivative time				Yes	Yes
		Heater burnout detection value					Yes
2: Digital Meters	Read	Display value	Yes	Yes	Yes	Yes	Yes
		Display status	Yes	Yes	Yes	Yes	Yes
		Peak hold		Yes	Yes		Yes
		Peak hold status		Yes	Yes		Yes
		Bottom hold		Yes	Yes		Yes
		Bottom hold status		Yes	Yes		Yes
		HH comparison value				Yes	Yes
		H comparison value				Yes	Yes
		L comparison value				Yes	Yes
		LL comparison value				Yes	Yes
	Write	Operation command			Yes		Yes
		HH comparison value				Yes	Yes
		H comparison value				Yes	Yes
		L comparison value				Yes	Yes
		LL comparison value				Yes	Yes

The command groups for which reading or writing is performed are determined by settings in the DM area.

**Specifications**

**General**

Item		Specification
Applicable PLC		CPM2C
RS-485/422 (top port)	Maximum number of connectable components	32
	Component connection port	Components connected to RS-485/422 terminal block. Connected to CPM2C CPU Unit via peripheral port (see diagram below).
	Baud rate for connection to components	9.6, 19.2, 38.4, or 57.6 kbps
	Baud rate for connection to CPU Unit	9.6 or 19.2 kbps
RS-232C (bottom port)	Signal conversion	Output from CPU Unit's RS-232C interface with no conversion
	Communications functions	One of the following: Host Link, no-protocol, 1:1 Link, 1:1 NT Link
Power supply		From CPU Unit
Power consumption		1 W
Weight		150 g max.

**System Configuration**

**Internal**

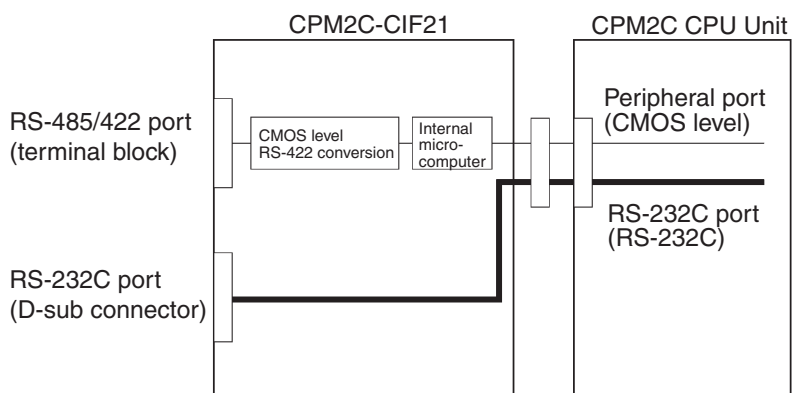

CPM2C-CIF□1(-V1)

# RS-232C / RS-422 / RS-485 Adapter Units

## System Configuration

### External Configuration

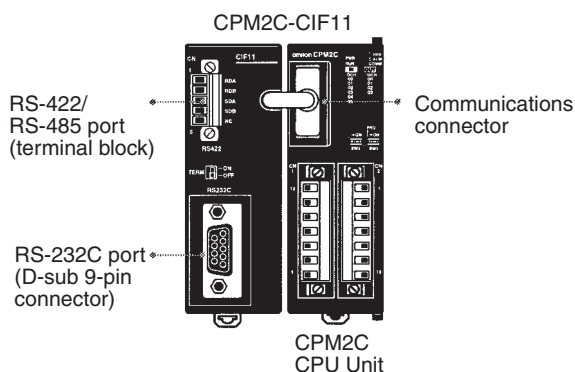
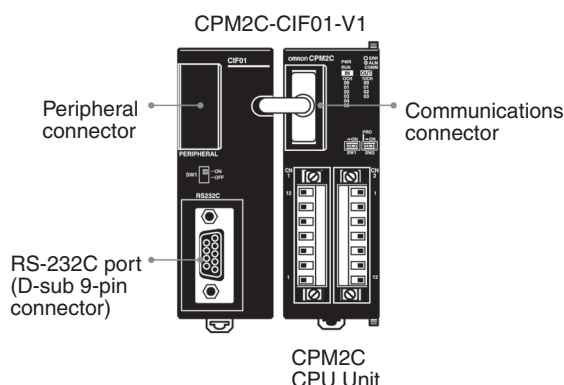

### Internal Configuration

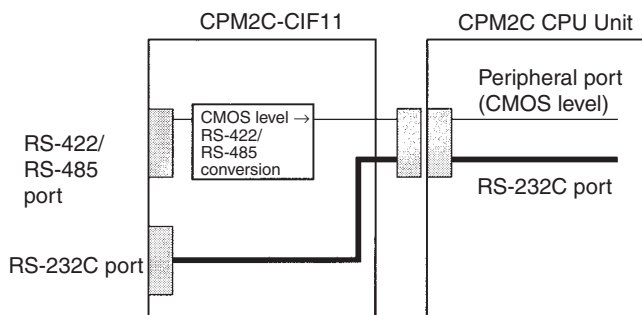
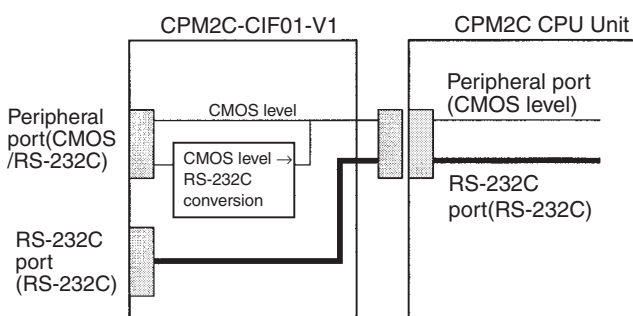

**Note:** When using the CS1W-CN226/CN626 Connecting Cable for personal computer connection, turn ON the switch.

**Note:** A Programming Console cannot be connected to the RS-422 port.

## Specifications

### General

Item	Specification	
	CPM2C-CIF01-V1	CPM2C-CIF11
Upper port	Signal conversion	Outputs signals from the CPU Unit's CMOS interface without conversion, or converts CMOS level (CPU Unit side) to RS-232C (connected device side).
	Function	Host Link, peripheral bus, no-protocol, or Programming Console connections.
Lower port	Signal conversion	Converts CMOS level (CPU Unit side) to RS-422 or RS-485 (connected device side). The externally connected device is insulated.
	Function	Host Link, peripheral bus, or no-protocol connections.
Power supply	Outputs signals from the CPU Unit's CMOS interface without conversion.	
Current consumption	Power supplied from CPU Unit.	
Weight	0.3 A max. at 5 V	
	150 g max.	

**Note:** Neither the CPM2C-CIF01-V1 nor the CPM2C-CIF11 can be used with any PLC other than the CPM2C. A CPM2C-CIF11 or another CPM2C-CIF01-V1 cannot be connected to the CPM2C if a CPM2C-CIF01-V1 is already connected to it.

CPM2C-SRT21

# CompoBus/S I/O Link Unit

**I/O Link Unit for CPM2C**

- Operates as a Slave of the CompoBus/S Master Unit.
- Exchanges eight inputs and eight outputs with the Master.



**Ordering Information**

**CompoBus I/O Link Unit**

Name	Specifications	Model
CompoBus/S I/O Link Unit	Number of points for I/O links: 8 inputs and 8 outputs	CPM2C-SRT21

**Application Examples**

**Conveyor Line**

Processing speed can be increased and system setup labor reduced by creating a distributed system with a CPM2C at each conveyor.

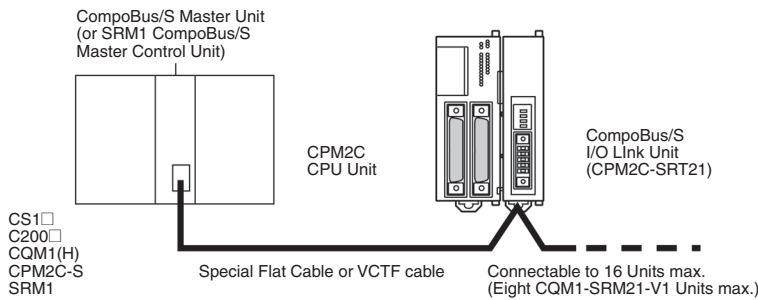

**Specifications**

Item	CPM2C-SRT21
Master/Slave	CompoBus/S Slave
Number of I/O points	8 inputs and 8 outputs
Number of words occupied in CPM2C's I/O memory	1 input word and 1 output word (allocated in the same way as for other Expansion Units)
Node address setting	DIP switch
Power consumption	1 W
Weight	150 g

**Note:** For details of CPM2C PLCs, refer to the CPM2C catalog (Cat. No. P049).

# CPM2C General Information

## System Configuration

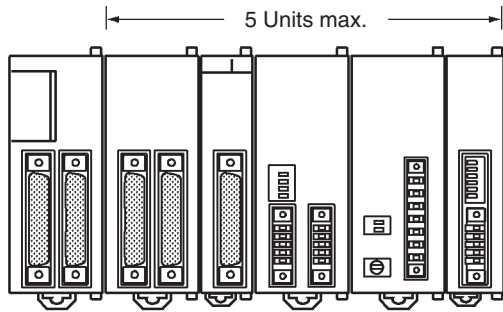

CPU Unit

### Number of Connectable Units

Up to 5 Units can be connected to a CPM2C CPU Unit except for the CPM2C-S1□OC-DRT Programmable Slave and CPM2C-S1□OC CompoBus/S Master Unit, which are limited to 3 Units. The number of words that can be used by Expansion Units, however, is limited, and these limits must not be exceeded.

Model	Max. No. of Units	Applicable I/O words
CPU Units except those listed below	5	Inputs: IR 001 to IR 009 (CPU Unit uses IR 000) Outputs: IR 011 to IR 019 (CPU Unit uses IR 010)
CPU Units with 32 I/O points (CPM2C-32CDT□C-D)	5	Inputs: IR 002 to IR 009 (CPU Unit uses IR 000 and IR 001) Outputs: IR 012 to IR 019 (CPU Unit uses IR 010 and IR 011)
CPM2C-S1□OC-DRT Programmable Slave and CPM2C-S1□OC CompoBus/S Master Unit	3	Inputs: IR 001 to IR 009 (CPU Unit uses IR 000) Outputs: IR 011 to IR 019 (CPU Unit uses IR 010)

### Number of I/O Words Allocated to Expansion Units

Unit	Model number	Input words	Output words
Expansion Input Units	CPM2C-8ED□	1	---
	CPM2C-16ED□	1	---
Expansion Output Units	CPM2C-8ER	---	1
	CPM2C-8ET(1)□	---	1
	CPM2C-16ET(1)□	---	1
Expansion I/O Units	CPM2C-10EDR	1	1
	CPM2C-24EDT(1)□	1	1
Expansion I/O Units	CPM2C-20EDR	1	1
	CPM2C-32EDT(1)□	1	1
Analog I/O Unit	CPM2C-MAD11	2	1
Temperature Sensor Units	CPM2C-TS001	2	---
	CPM2C-TS101	2	---
CompoBus/S I/O Link Unit	CPM2C-SRT21	1	1

- Note:**
1. An AC Power Supply Unit can be used for the CPU Units.
  2. The CPM2C-CIF01-V1/CIF11/CIF21 can be used with the CPU Units

Unit	Model number	Inputs	Outputs
CPU Unit	CPM2C-20CDTC-D	IR 000	IR 010
Expansion I/O Unit	CPM2C-24EDTC	IR 001	IR 011
Expansion Output Unit	CPM2C-16ETC	---	IR 012
Analog I/O Unit	CPM2C-MAD11	IR 002 IR 003	IR 013
Temperature Sensor Unit	CPM2C-TS001	IR 004 IR 005	---
CompoBus/S I/O Link Unit	CPM2C-SRT21	IR 006	IR 014

### CPM2C Power Consumption

Use the following power consumption tables to calculate the total power capacity required when using a CPM2C PC. The rated output for the CPM2C-PA201 AC Power Supply Unit is 15 W. Any surplus power not required for the PC directly can be used as service power supply for sensors and other devices.

### CPM2C Power Supplies

CPU Unit	Power consumption (W)
CPM2C-10C(1)DR-D	4
CPM2C-20C(1)DR-D	4
CPM2C-S1□OC-DRT1	3
CPM2C-S1□OC	3
CPM2C-10C(1)DT(1)□-D	3
CPM2C-20C(1)DT(1)□-D	3
CPM2C-32C(1)DT(1)□-D	3

The power consumption of the CPU Unit includes power for the Programming Consoles and Adapter Units.

Add the following consumptions when using Expansion I/O Units.

Expansion I/O Unit	Power consumption (W)
CPM2C-10EDR	1
CPM2C-20EDR	2
CPM2C-24EDT(1)□	1
CPM2C-32EDT(1)□	1
CPM2C-MAD11	3.5
CPM2C-SRT21	1
CPM2C-TS001/002	1.5
CPM2C-8ED□/16ED□	1
CPM2C-8ER	2
CPM2C-8ET(1)□/16ET(1)□	1

# Dimensions

## CPU Units

**CPU Units with Relay Outputs**  
(CPM2C-10C(1)DR-D, CPM2C-20C(1)DR-D)

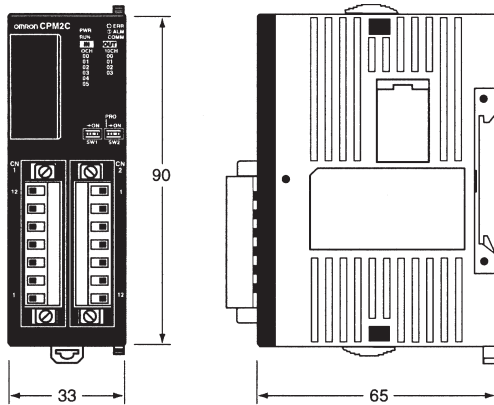

**CPU Units with Transistor Outputs**  
(CPM2C-10C(1)DT(1)C-D, CPM2C-10C(1)DT(1)M-D,  
CPM2C-20C(1)DT(1)C-D, CPM2C-20C(1)DT(1)M-D,  
CPM2C-32CDT(1)C-D, CPM2C-32CDT(1)M-D)

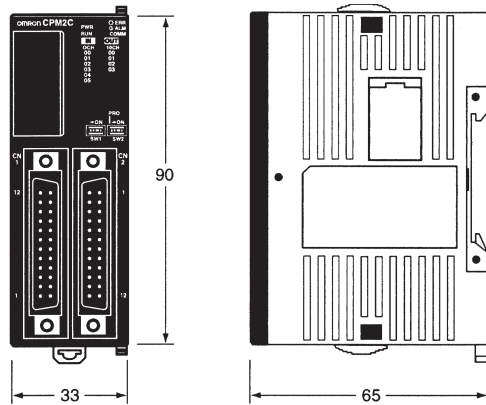

**CPU Units with Relay Outputs**  
(CPM2C-S1□0C)

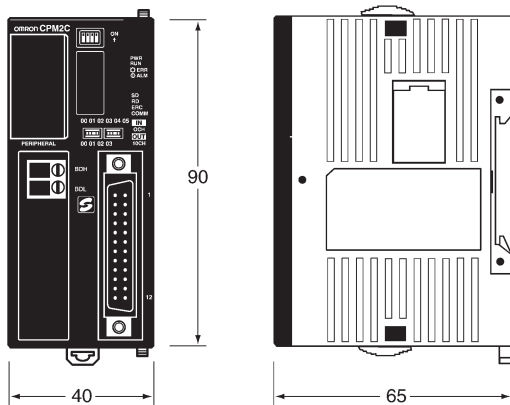

**CPU Units with Transistor Outputs**  
(CPM2C-S1□0C-DRT)

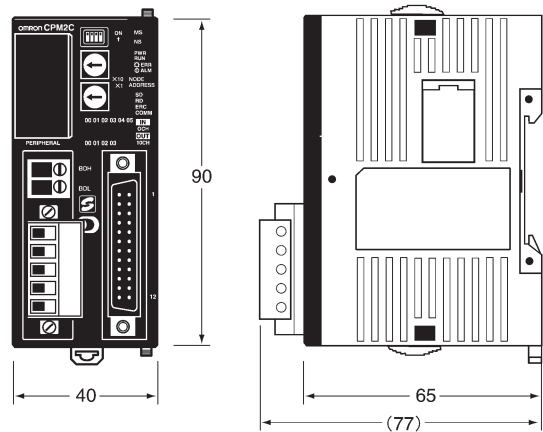

**Note:** All dimensions are in mm.

I/O Expansion Units

**Units with Relay Outputs**  
(CPM2C-8ER, CPM2C-10EDR, CPM2C-20EDR)

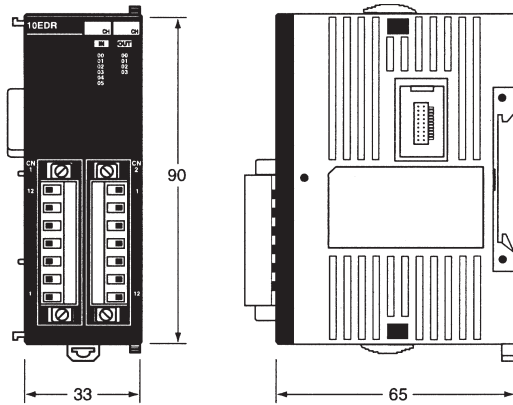

**Units with Transistor Outputs**  
(CPM2C-24EDT(1)C, CPM2C-24EDT(1)M,  
CPM2C-32EDT(1)C, CPM2C-32EDT(1)M)

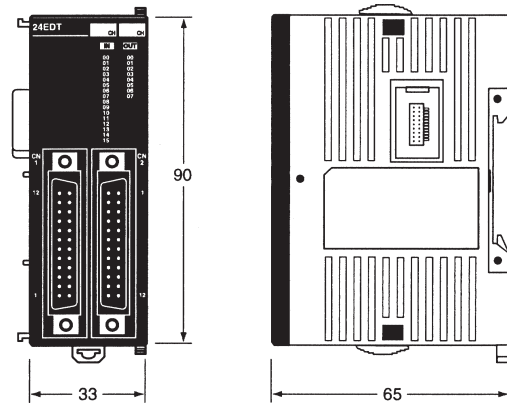

**Units with Transistor Outputs Only and Units with Inputs Only**  
(CPM2C-8ED(1), CPM2C-8ET(1)C, CPM2C-8ET(1)M,  
CPM2C-16ED(1), CPM2C-16ET(1)C, CPM2C-16ET(1)M)

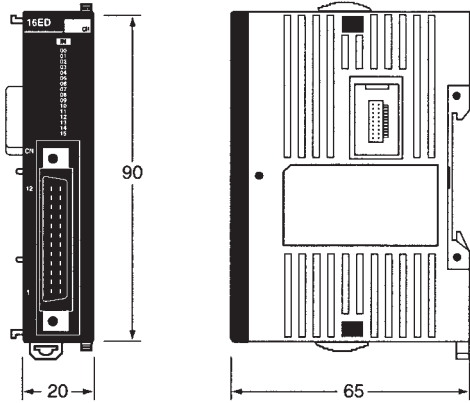

Note: All dimensions are in mm.

**AC Power Supply Unit**  
(CPM2C-PA201)

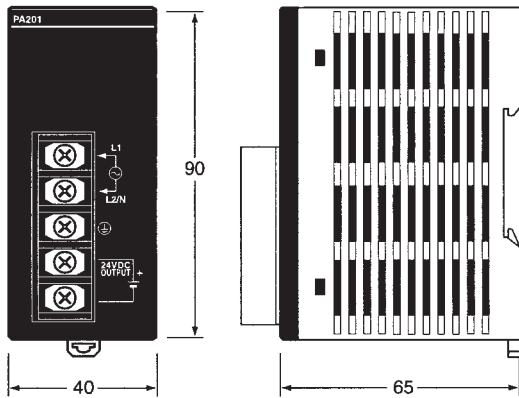

Analog I/O Unit  
(CPM2C-MAD11)

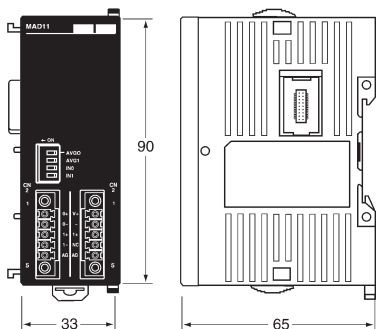

Temperature Sensor Unit  
(CPM2C-TS001, CPM2C-TS101)

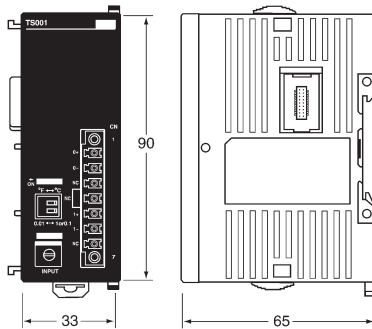

CompoBus/S I/O Link Unit  
(CPM2C-SRT21)

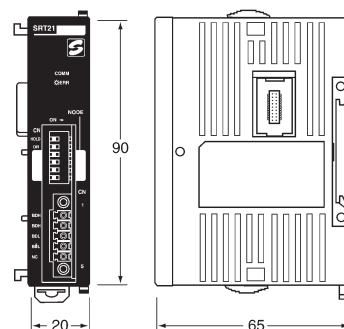

Simple Communications Unit  
(CPM2C-CIF21)

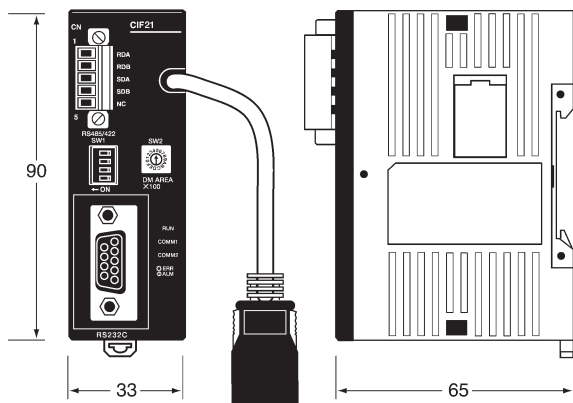

Peripheral/RS-232C Adapter Unit  
(CPM2C-CIF01-V1)

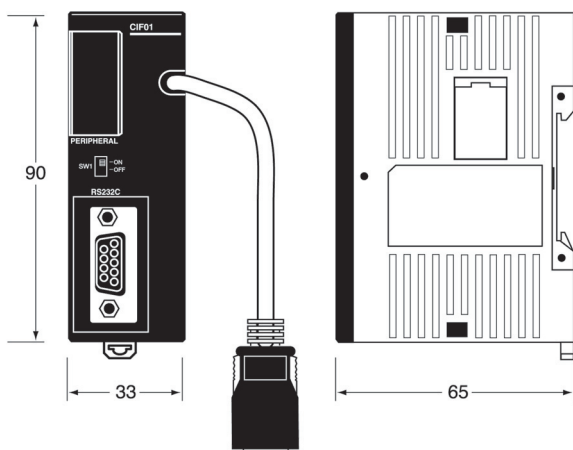

RS-422/RS-485/RS-232C Adapter Unit  
(CPM2C-CIF11)

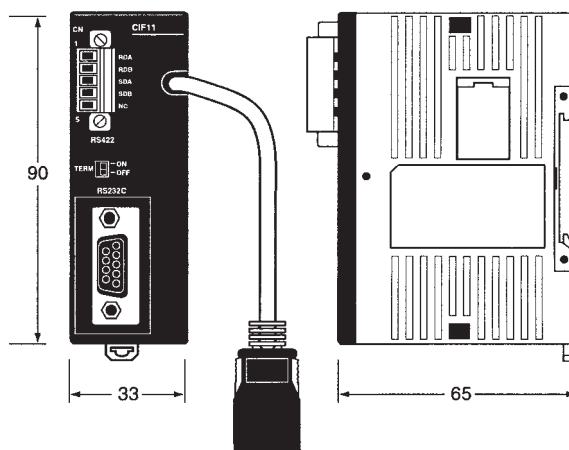

# CPM2C Ordering Information

## International Standards

The products shown in the attached tables are those that conform to the UL, CSA, cULus, cUL, NK, Lloyd's Register, and EC Directives as of September 2003.

(U: UL, C: CSA, UC: cULus, CU: cUL, N: NK, L: Lloyd, CE: EC Directives)

Please contact OMRON representative for application conditions.

## CPM2C CPU Units

CPU Unit	Inputs	Outputs	Internal clock	Model	Standards	
Units with 10 I/O points Inputs: 6 Outputs: 4	I/O terminal block	6 inputs (24 V DC)	4 relay outputs	---	CPM2C-10CDR-D	U, C, CE
				Yes	CPM2C-10C1DR-D	
Units with 10 I/O points Inputs: 6 Outputs: 4	2 Fujitsu connectors	6 inputs (24 V DC)	4 sinking transistor outputs	---	CPM2C-10CDTC-D	U, C, CE
			4 sourcing transistor outputs	---	CPM2C-10CDT1C-D	
			4 sinking transistor outputs	Yes	CPM2C-10C1DTM-D	
			4 sourcing transistor outputs	Yes	CPM2C-10C1DT1M-D	
	2 MIL connectors	6 inputs (24 V DC)	4 sinking transistor outputs	---	CPM2C-10CDTM-D	U, C, CE
			4 sinking transistor outputs	Yes	CPM2C-10C1DTM-D	
			4 sourcing transistor outputs	---	CPM2C-10CDT1M-D	
			4 sourcing transistor outputs	Yes	CPM2C-10C1DT1M-D	
Units with 20 I/O points Inputs: 12 Outputs: 8	2 terminal blocks	12 inputs (24 V DC)	8 relays	---	CPM2C-20CDR-D	U, C, CE
			8 sinking transistor outputs	---	CPM2C-20CDTC-D	
			8 sourcing transistor outputs	---	CPM2C-20CDT1C-D	
			8 sourcing transistor outputs	Yes	CPM2C-20C1DT1M-D	
	2 Fujitsu connectors	12 inputs (24 V DC)	8 sinking transistor outputs	---	CPM2C-20CDTM-D	U, C, CE
			8 sinking transistor outputs	Yes	CPM2C-20C1DTM-D	
			8 sourcing transistor outputs	---	CPM2C-20CDT1M-D	
			8 sourcing transistor outputs	Yes	CPM2C-20C1DT1M-D	
Units with 32 I/O points Inputs: 16 Outputs: 16	2 Fujitsu connectors	16 inputs (24 V DC)	16 sinking transistor outputs	---	CPM2C-32CDTC-D	U, C, CE
			16 sourcing transistor outputs	---	CPM2C-32CDT1C-D	
	2 MIL connectors	16 inputs (24 V DC)	16 sinking transistor outputs	---	CPM2C-32CDTM-D	U, C, CE
			16 sourcing transistor outputs	---	CPM2C-32CDT1M-D	
Programmable Slave with DeviceNet slave and CompoBus/S Master, 10 I/O points Inputs: 6 Outputs: 4	1 Fujitsu connector	6 inputs (24 V DC)	4 sinking transistor outputs	Yes	CPM2C-S100C-DRT	U, C, CE
			4 sourcing transistor outputs	Yes	CPM2C-S110C-DRT	
Units with CompoBus/S Master, 10 I/O points Inputs: 6 Outputs: 4	1 Fujitsu connector	6 inputs (24 V DC)	4 sinking transistor outputs	Yes	CPM2C-S100C	U, C, CE
			4 sourcing transistor outputs	Yes	CPM2C-S110C	

## Power Supply Unit

Unit	Input	Output	Model	Standards
AC Power Supply Unit	100 to 240 V AC	24 V DC/600 mA	CPM2C-PA201	U, C, CE

## Expansion I/O Units

Expansion I/O Unit	Inputs	Outputs	Model	Standards	
Units with inputs only Inputs: 8	1 Fujitsu connector	8 inputs (24 V DC)	---	CPM2C-8EDC	U, C, CE
	1 MIL connector	8 inputs (24 V DC)	---	CPM2C-8EDM	
Units with inputs only Inputs: 16	1 Fujitsu connector	16 inputs (24 V DC)	---	CPM2C-16EDC	U, C, CE
	1 MIL connector	16 inputs (24 V DC)	---	CPM2C-16EDM	
Units with relay outputs only Outputs: 8	I/O terminal block	---	8 relay outputs	CPM2C-8ER	U, C, CE
			8 sinking transistor outputs	CPM2C-8ETC	
	1 Fujitsu connector	---	8 sourcing transistor outputs	CPM2C-8ET1C	U, C, CE
			8 sinking transistor outputs	CPM2C-8ETM	
1 MIL connector	---	8 sourcing transistor outputs	CPM2C-8ET1M	U, C, CE	
		8 sinking transistor outputs	CPM2C-8ETM		
Units with transistor outputs only Outputs: 8	1 Fujitsu connector	---	16 sinking transistor outputs	CPM2C-16ETC	U, C, CE
			16 sourcing transistor outputs	CPM2C-16ET1C	
	1 MIL connector	---	16 sinking transistor outputs	CPM2C-16ETM	U, C, CE
			16 sourcing transistor outputs	CPM2C-16ET1M	
Units with 10 I/O points Inputs: 6 Outputs: 4	1 I/O terminal block	6 inputs (24 V DC)	4 relay outputs	CPM2C-10EDR	U, C, CE

Expansion I/O Unit		Inputs	Outputs	Model	Standards
Units with 20 I/O points	1 I/O terminal block	12 inputs (24 V DC)	8 relay outputs	CPM2C-20EDR	U, C, CE
Inputs: 12 Outputs: 8					
Units with 24 I/O points	2 Fujitsu connectors	16 inputs (24 V DC)	8 sinking transistor outputs	CPM2C-24EDTC	U, C, CE
			8 sourcing transistor outputs	CPM2C-24EDT1	U, C, CE
Inputs: 16 Outputs: 8	2 MIL connectors	16 inputs (24 V DC)	8 sinking transistor outputs	CPM2C-24EDTM	U, C, CE
			8 sourcing transistor outputs	CPM2C-24EDT1M	U, C, CE
Units with 32 I/O points	2 Fujitsu connectors	16 inputs (24 V DC)	16 sinking transistor outputs	CPM2C-32EDTC	U, C, CE
			16 sourcing transistor outputs	CPM2C-32EDT1C	U, C, CE
Inputs: 16 Outputs: 16	2 MIL connectors	16 inputs (24 V DC)	16 sinking transistor outputs	CPM2C-32EDTM	U, C, CE
			16 sourcing transistor outputs	CPM2C-32EDT1M	U, C, CE

### Analog I/O Units

Product	Specifications	Model	Standards
Analog I/O Unit	2 analog inputs and 1 analog output	CPM2C-MAD11	CE

### Temperature Sensor Unit

Product	Specifications	Model	Standards
Temperature Sensor Unit	2 inputs for thermocouples	CPM2C-TS001	CE
	2 inputs for temperature resistance thermometers	CPM2C-TS101	

### CompoBus/S I/O Link Units

Product	Specifications	Model	Standards
CompoBus/S I/O Link Units	I/O Links: 8 inputs, 8 outputs	CPM2C-SRT21	CE

### I/O Connectors

(Connectors are not provided with CPU Unit. Select the appropriate ones from the following table. One CPU Unit requires two sets of Connectors.)

#### Fujitsu Connectors

Connection method	From OMRON		From Fujitsu
Soldered	C500-CE241	1 set	FCN-361J024-AUConnector FCN-360C024-J2Connector Cover
Crimped	C500-CE242		FCN-363J024Housing FCN-363J-AUCContacts FCN-360C024-J2Connector Cover
Pressure-welded	C500-CE243		FCN-367J024-AU/F

#### MIL Connectors

Connection method	Model	Number in box	Specifications
Pressure-welded	XG4M-2030-T	100	Poles: 20

**Note:** Any commercially available 20-pole (IDC) connectors, according to MIL-C-83503, DIN 41651 or IEC 60603-1 specification, can be used.

### Programming Consoles and Cables

Product	Model	Standards	
Programming Console (2-m cable attached)	CQM1-PRO01-E	U, C, CE, N	
Programming Console (Requires separate cable. See below.)	C200H-PRO27-E	U, C, N, CE	
Connecting Cable for connecting CQM1-PRO01-E to a peripheral port	CS1W-CN114	CE	
Connecting Cable for C200H-PRO27-E	2-m cable	C200H-CN222	N
	4-m cable	C200H-CN422	---
Connecting Cable for C200H-PRO27-E allowing direct connection to the CPM2C CPU Unit	2-m cable	CS1W-CN224	CE
	6-m cable	CS1W-CN624	CE

### Support Software

Product	Functions	Model	Standards
CX-One	Omron's integrated software for programming and configuration of all control system components, including PLCs, HMI, drives, temperature controllers and advanced sensors.	CX-ONE-AL□□C-E* <sup>1</sup>	---

\*1 □□ = Number of licenses (01, 03, 10)

Product	Model	Standards
Expansion Memory Unit	CPM1-EMU01-V1	---
EEPROM (256 K)	EEROM-JD	---

Peripheral Port Adapters and Connecting Cables

Description		Computer port	Length	Model	Standards
Personal Computer Connecting Cables	Peripheral Port Cable	For a D-sub 9-pin port	2 m	CS1W-CN226	CE
			6 m	CS1W-CN626	CE
			3.3 m	CQM1-CIF02	U, C, N, L, CE
			0.05 m	CS1W-CN114	CE

RS-232C Cables

Product	Computer port	Specifications	Length	Model	Standards
RS-232C Cable	For a D-sub 9-pin port	Can be used with a peripheral bus or Host Link. Uses connector that prevents ESD (electrostatic discharge.)	2 m	XW2Z-200S-V	---
			5 m	XW2Z-500S-V	---
			2 m	XW2Z-200S-CV	---
			5 m	XW2Z-500S-CV	---

Communications Port Connecting Cables

Description	Cable length	Model	Standards
Converts to a Peripheral port and RS-232C port.	0.1 m (about 4")	CPM2C-CN111	CE
Converts to a Peripheral port only.	0.05 m (about 2")	CS1W-CN114	CE
Converts to an RS-232C port only.	0.1 m (about 4")	CS1W-CN118	CE

Simple Communications Unit

Product	Specifications	Model	Standards
Simple Communications Unit	RS-485/RS-232C ports for connection to components	CPM2C-CIF21	U, C, CE

Adapters

Product	Function	Model	Standards
Peripheral/RS 232C Adapter Unit	Peripheral port level conversion	CPM2C-CIF01-V1	---
RS-422/RS-485/RS-232C Adapter Unit		CPM2C-CIF11	U, C, CE
Link Adapter	RS-232C to RS-422A conversion	3G2A9-AL004-E	---
RS-422A Adapter		NT-AL001	---

Battery

Product	Function	Model	Standards
Battery	Backs up memory in the CPM2C CPU Unit.	CPM2C-BAT01	CE

I/O Terminal Blocks and Connecting Cables

Product	Description	No. of inputs/outputs	Model	Comments
I/O Terminal Blocks	Slim type with M3 slotted screw terminal block	20	XW2D-20G6	For more information refer to "Wiring Systems" on page 384
	Flat cable connector with M2.5 slotted screw terminal block	20	XW2B-20G4	
Common terminals (3-tier inputs)	---		XW2E-20G5-IN16	
Common terminals (2-tier outputs)	---		XW2C-20G6-IO16	

Product	Cable length	Model	Comments	
Special Connecting Cable	With Fujitsu connector	0.5 m	XW2Z-050A	For more information refer to "Wiring Systems" on page 384
		1 m	XW2Z-100A	
		1.5 m	XW2Z-150A	
		2 m	XW2Z-200A	
		3 m	XW2Z-300A	
		5 m	XW2Z-500A	
	With MIL connector	2.5 m	G79-025C	
		5 m	G79-050C	

Relay I/O Terminals and Connecting Cables

Product	Mounted relay	I/O points	Processing	Rated voltage	Model	Standards	Output	Fujitsu connector	MIL connector
Relay I/O terminals	G7TC	16 inputs	NPN (– common)	24 V DC	G7TC-ID16	---	---	G79-□00C	G79-O□00C
				100 (110) V AC	G7TC-IA16				
				200 (220) V AC					
		16 outputs	NPN (+ common, sinking output)	24 V DC	G7TC-OC16	Sink	G79-□00C	G79-O□00C	
	16 outputs	PNP (– common, sourcing output)	24 V DC	G7TC-OC16-1	Source	G79-□00C	G79-O□00C		
	8 outputs	NPN (+ common, sinking output)	24 V DC	G7TC-OC08	---	Sink	G79-□00C	G79-O□00C	
	G6D	16 outputs	NPN (+ common, sinking output)	24 V DC	G70D-SOC16	---	Sink	G79-□00C	G79-O□00C
			PNP (– common, sourcing output)	24 V DC	G70D-SOC16-1	---	Source		G79-□00C
	G3DZ (Power MOSFET Relay)	16 outputs	NPN (+ common, sinking output)	24 V DC	G70D-FOM16	---	Sink	G79-□00C	G79-O□00C
			PNP (– common, sourcing output)	24 V DC	G70D-FOM16-1	---	Source		G79-□00C
	G6D	16 outputs	NPN (+ common, sinking output)	24 V DC	G70D-VSOC16	---	Sink	G79-□00C	G79-O□00C
	G3DZ (Power MOSFET Relay) (Sold separately) G2R G3R G3RN H3RN	16 outputs	NPN (+ common, sinking output)	24 V DC	G70D-VFOM16	---	Sink	G79-□00C	G79-O□00C
			NPN (+ common, sinking output)	24 V DC	G70A-ZOC16-3	---	Sink	G79-□00C	G79-O□00C
			PNP (– common, sourcing output)			G70A-ZOC16-4	---	Source	---

Product	Cable length	Model	Comments
Connecting Cable with connector (1:1)	With Fujitsu connector	1 m	G79-100C
		1.5 m	G79-150C
		2 m	G79-200C
		3 m	G79-300C
		5 m	G79-500C
	With MIL connector	0.25 m	G79-O25C
		5 m	G79-O50C
		0.25 m	G79-I25C
		0.5 m	G79-I50C
			For more information refer to "Wiring Systems" on page 384

DC Power Supplies

Product	Output voltage/current	Input voltage	Model	Standards
DC Power Supply (3 W)	24 V DC, 0.13 A	85 V AC to 264 V AC	S82K-00324	U, C
DC Power Supply (7.5 W)	24 V DC, 0.3 A	85 V AC to 264 V AC	S82K-00724	U, C
DC Power Supply (15 W)	24 V DC, 0.6 A	85 V AC to 264 V AC	S82K-01524	U, C
DC Power Supply (30 W)	24 V DC, 1.3 A	85 V AC to 264 V AC	S82K-03024	U, C
DC Power Supply (50 W)	24 V DC, 2.1 A	85 V AC to 264 V AC	S82K-05024	U, C

ALL DIMENSIONS SHOWN ARE IN MILLIMETERS.  
To convert millimeters into inches, multiply by 0.03937. To convert grams into ounces, multiply by 0.03527.

Compact PLC series

# CP1H

## The All-in-One Controller

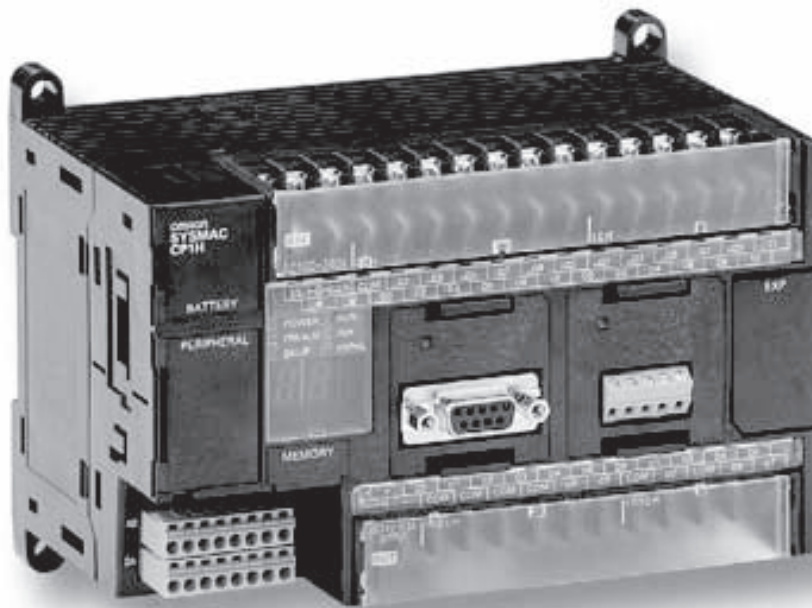

Combining the processing power and data capacity of the CJ1M series and the built-in digital I/O functionality of the CPM2A series in a compact PLC outline, the CP1H CPU series sets new standards.

With 4 high-speed encoder inputs up to 1 MHz (single phase) and 4 pulse outputs up to 1 MHz (line driver), CP1H CPUs are ideal for positioning and speed control.

Their optional 4 analogue inputs and 2 analogue outputs plus advanced PID control with auto-tuning also make them ideal for continuous control applications.

What's more, expandable with CPM1A I/O units (up to 320 I/O points) and up to two CJ1 Special I/O units or CPU bus units, CP1H CPUs offer a wide range of communication interfaces and advanced I/O units.

Equipped with a USB interface as standard for programming and monitoring, the new CPUs allows up to two serial ports to be plugged in for communication with HMI or field devices. And, of course, they provide 'Smart Platform' communication routing over multiple network layers.

Using CX-One, programs can be created that enable the user to build, configure and program networks, PLCs, HMIs, motion-control systems, drives, temperature controllers and sensors.

The CP1H CPU series has the same architecture as the CS/CJ PLC series, which means programs are compatible for memory allocations and instructions and also support Function Blocks and Structured Text.

# High-speed counter / encoder input

## Four axes Counter Function (single phase or differential phase)

CP1H-X(A) CPU Units: Four axes, single-phase at 100 kHz or differential phases at 50 kHz  
 CP1H-Y CPU Units: Two axes, single phase at 1 MHz or differential phases at 500 kHz plus two axes, single phase at 100 kHz or differential phases at 50 kHz

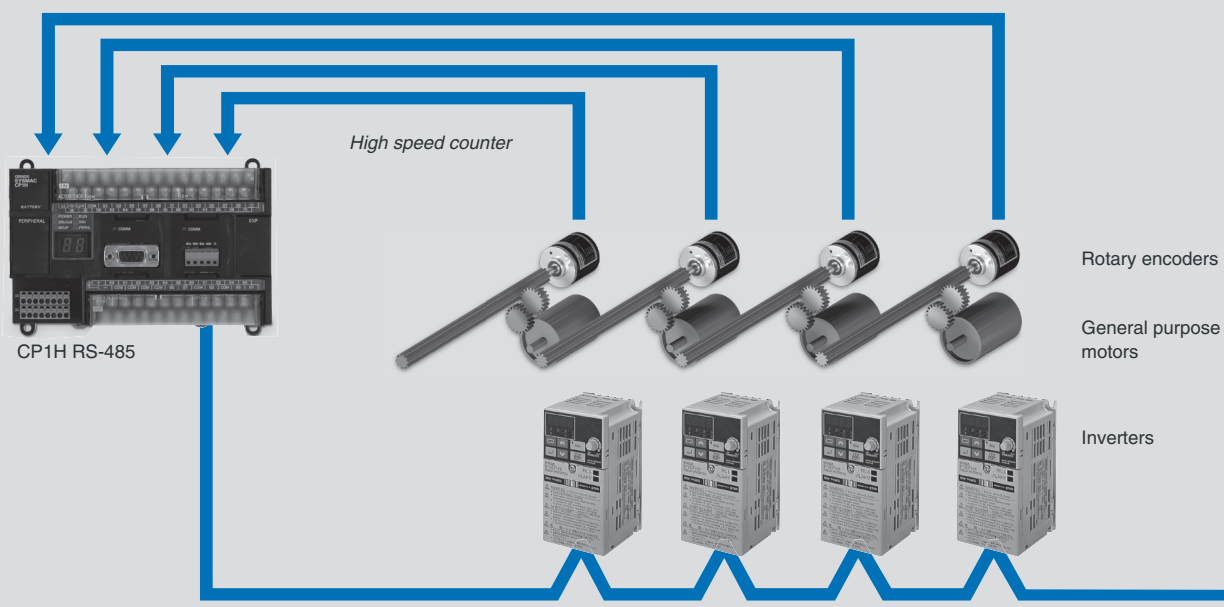

### Eight Interrupt Inputs

**Eight inputs be used as:**

- 50  $\mu$ s pulse catch inputs
- interrupt inputs
- simple counter inputs (<5 kHz)

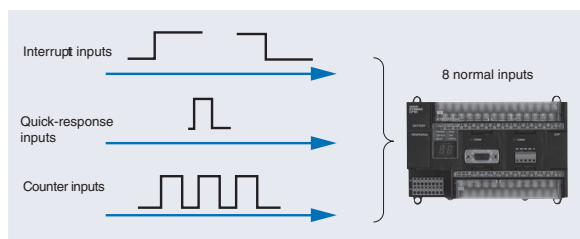

### Program execution speed

Fast I/O requires fast response, the CJ1M core provides class-leading program execution speed.

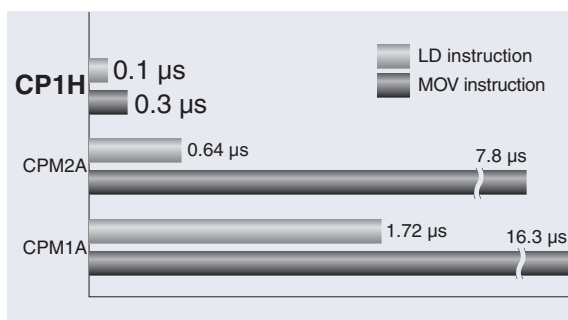

# 4 Pulse outputs for precise positioning

**Pulse Output Function for Up to Four Axes.**

CP1H-X(A) CPU Units: Two axes at 100 kHz and two axes at 30 kHz  
 CP1H-Y CPU Units: Two axes at 1 MHz and two axes at 100 kHz

*Pulse outputs*

Servo drivers

Servomotors

**Example: Four-axes Control in Electronic Component manufacturing equipment**

## Easy engineering with standard functions

- Single-instruction Origin Search Function
- Positioning with Trapezoidal Acceleration and Deceleration (PLS2 Instruction)

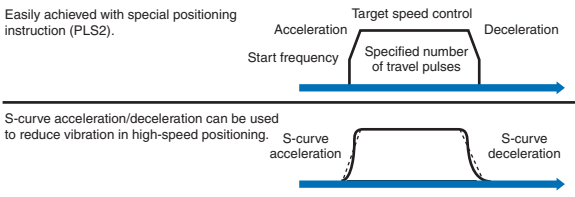

## Interrupt Feeding (ACC and PLS2 Instructions)

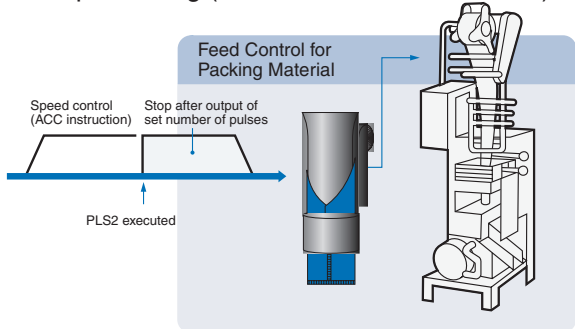

## 1MHz High-speed Pulse Output (CP1H-Y CPU Units : To be released soon.)

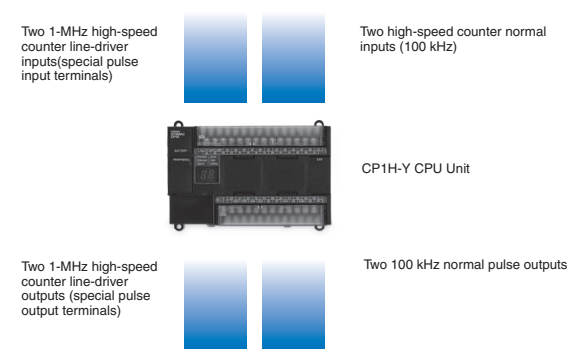

### CP1H-Y CPU Units offer built-in 1-MHz line-driver I/O.

- Line-driver outputs: Two each for CW and CCW.
  - Line-driver inputs: Two each for phases A, B, and Z.
- CP1H-Y CPU Units also have 20 normal I/O points (12 inputs and 8 outputs), and can provide 100-kHz high-speed counter inputs for two axes and 100 kHz pulse outputs for two axes.

# Analogue I/O

## Analogue Control without Using Expansion Units

CP1H-XA CPU Units have four analogue inputs and two analogue outputs built in.

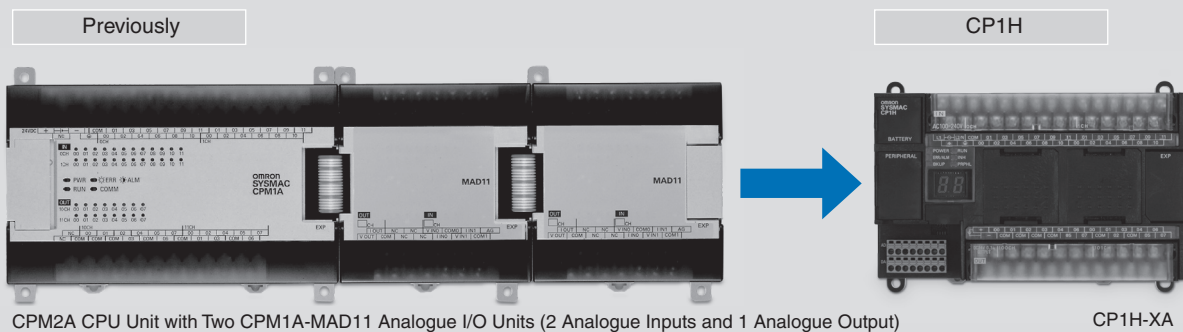

### • Oil Pressure Control

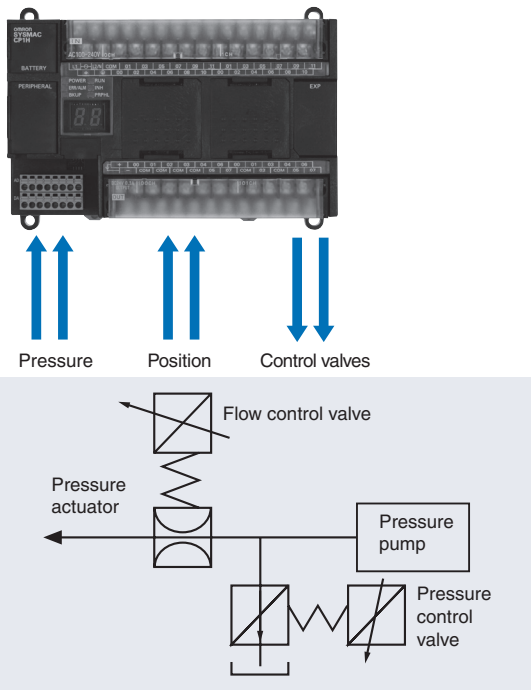

### • Inspection Devices

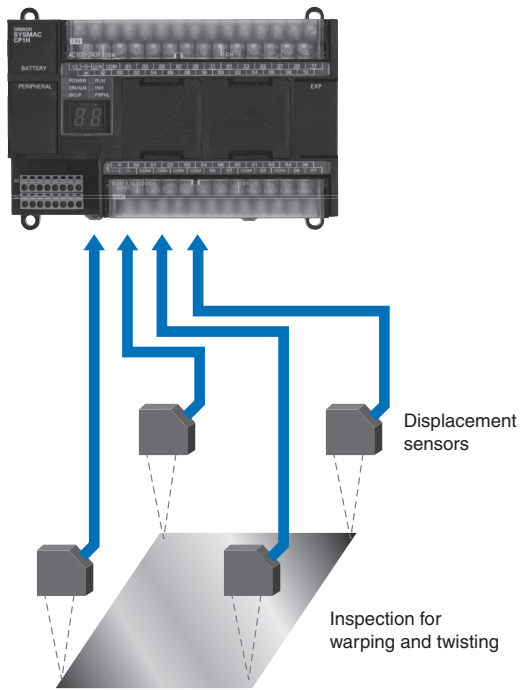

# Serial communications

Two Option Boards can be mounted for RS-232C or RS-422A/485 communications making it easy to simultaneously connect to a PT, and other devices such as Inverters, Temperature controllers, Smart Sensors or Serial PLC link. The standard USB port is used for connection to a personal computer.

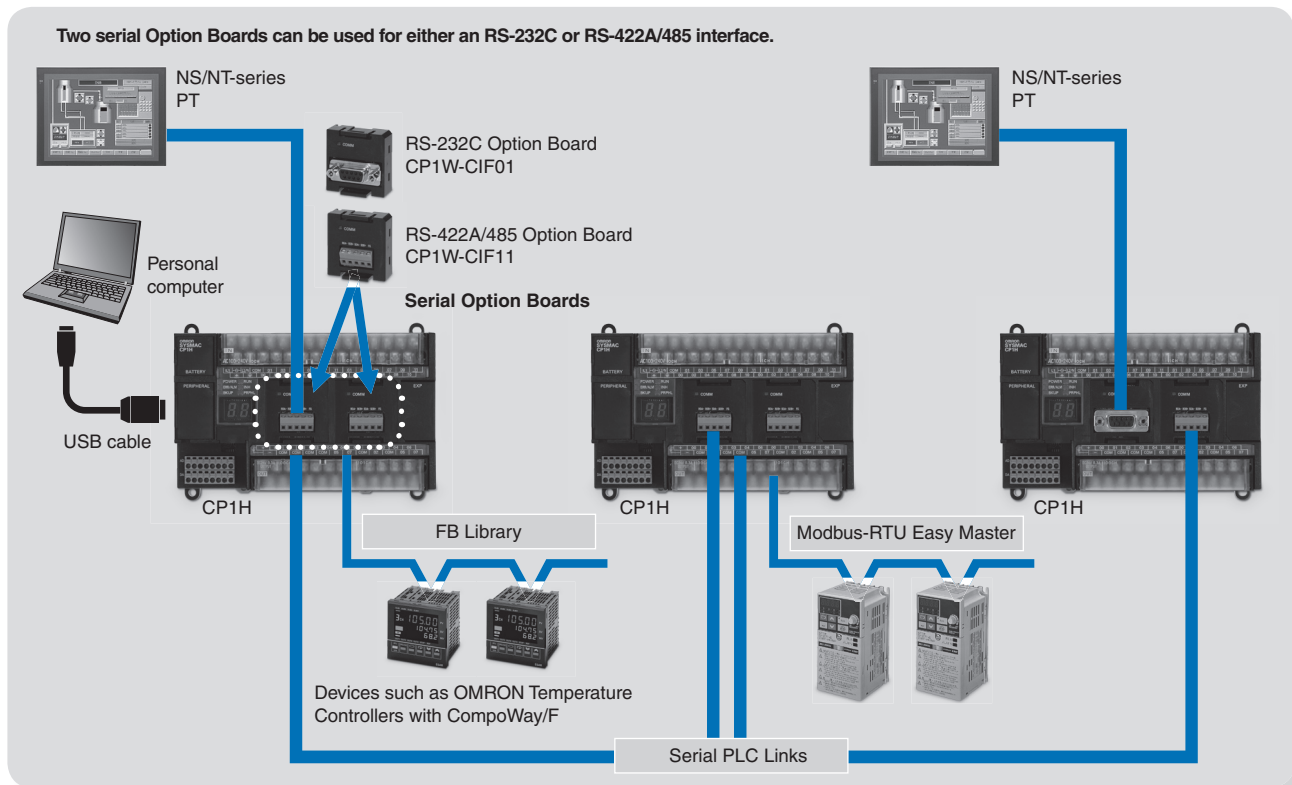

## Modbus-RTU Easy Master

The Modbus-RTU Easy Master makes it easy to control Modbus slaves (such as Inverters). Serial communications can be executed independently of the program simply by setting a Modbus command in a fixed memory area and turning ON software switches.

• Command	Port 1: D32200	~	D32249	
	Port 2: D32300	~	D32349	
	Slave address (00 to F7 hex)	Function code	Number of bytes	Data (94 bytes max.)
• Response	Port 1: D32300	~	D32299	
	Port 2: D32350	~	D32399	
	Slave address	Function code	Error code	Number of bytes
				Data (93 bytes max.)

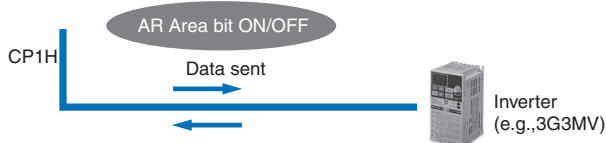

## Serial PLC Links

Up to 10 Words/Unit of data can be exchanged between up to nine CP1H (or CJ1M) CPU units.

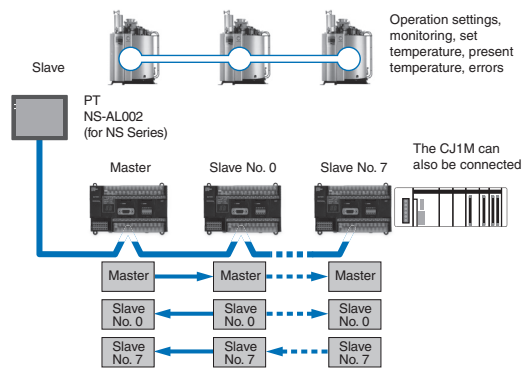

NS/NT-series PTs can also be incorporated as slaves (1:N NT Link connections) to exchange data using the NT Links with only the master CP1H. Each is treated as one slave node.

# Reduce development time with efficient tools

- Plug-and-play USB Connection

Just install the CX-Programmer (Ver. 6.1 or higher) and connect the USB cable to the CP1H. The driver will be installed automatically.



- A Built-in USB Port (USB 1.1, Type B) Enables a Personal Computer to Be Connected using a standard USB cable.

Standard A-type male to B-type male USB cables can be used.



Note: Programming Consoles (e.g., COM1H-PRO01 and C200H-PRO27) cannot be used with the CP1H.

## A Wealth of Instructions

- PID Instruction with Autotuning

PID constants can be automatically tuned for the PID instruction. The limit cycle method is used for tuning, allowing tuning to be completed quickly

- Floating-point Decimal Instructions, Trigonometric Instructions, and More.

Just like the CS/CJ-series PLCs, the CP1H has approximately 400 instructions for ladder programming.

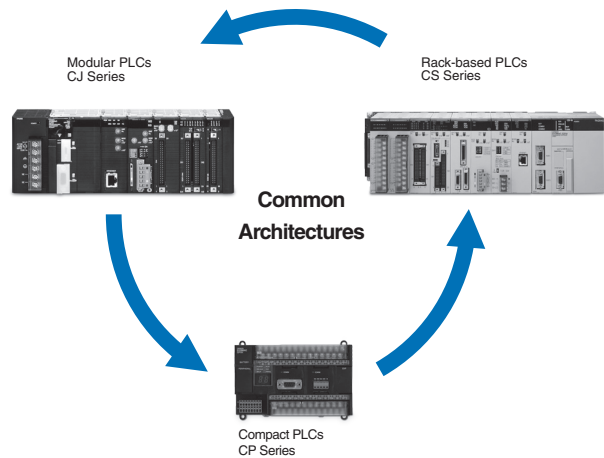

## The Structured Text (ST) language makes arithmetic operations even easier.

In addition to ladder programming, function block logic can be written in ST language, which conforms to IEC 61131-3. Arithmetic processing is also possible with ST, including processing of absolute values, square roots, logarithms, and trigonometric functions (SIN, COS, and TAN). Processing that is difficult to write in ladder programming becomes easy using structured text.

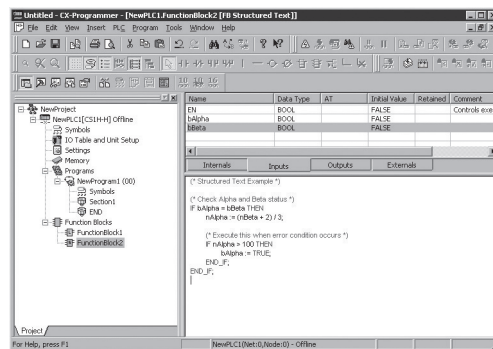

Communications programs are provided by the Function Block library.

OMRON's Function Block Libraries drastically reduce the amount of programming needed to communicate with field devices. Just drag and drop a pre-tested function block in your program and set the parameters. You'll be up and running within one minute.

• A FB Library for Pulse Outputs.

Function blocks are also provided for pulse outputs to make it easy to write programs for positioning in addition to communications function blocks. These function blocks will reduce the time required for developing programs for applications such as for OMRON's Smartstep Servo System.

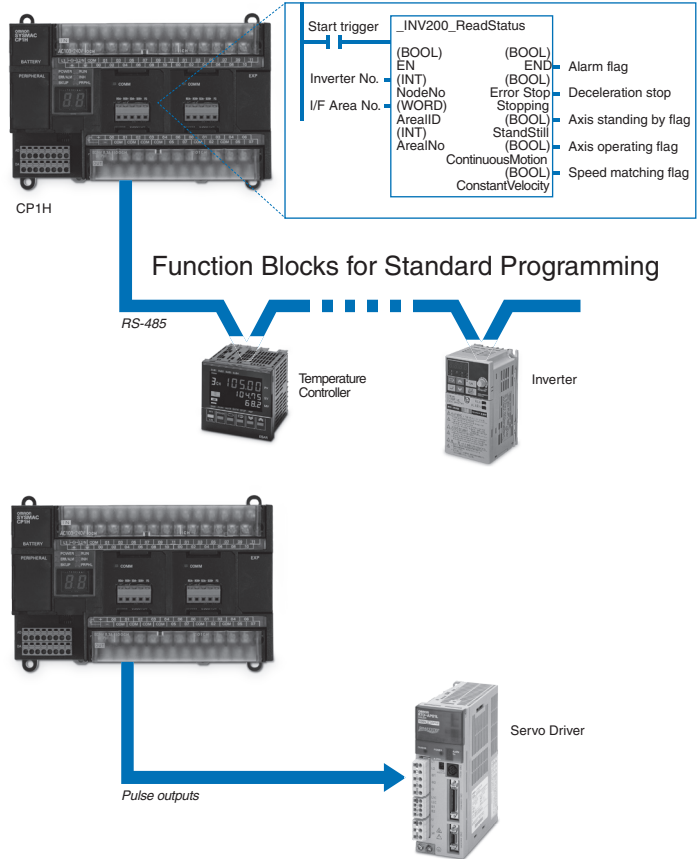

Security

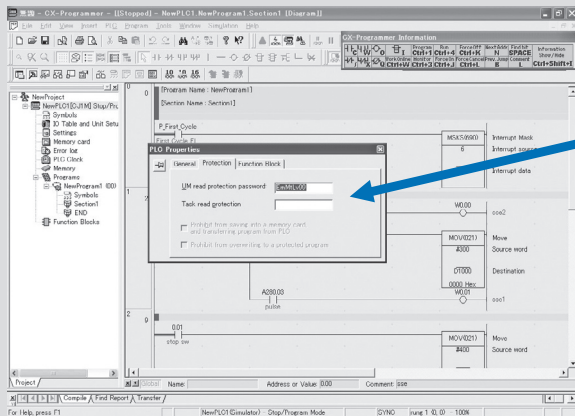

Programs can be protected by setting a password from the CX-Programmer (with the PLC online).

Password setting: Up to 8 alphanumeric characters (A-Z, a-z, 0-9)

# One software, one connection, one minute

## CX-One

CX-One is a single programming and configuration environment that enables the user to build, configure and program networks, PLCs, HMIs, Motion Control systems, Drives, Temperature Controllers and Sensors. The result of a single software is to reduce complexity of the configuration, allowing automation systems to be programmed or configured with minimal training.

### • CX-Integrator

Settings and configurations for devices can be made from any PLC in the network.

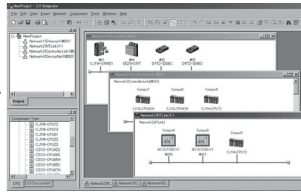

### • CX-Designer

The CX-Designer can be started from the CX-Integrator. Settings such as the PLC and Unit information are passed to the CXDesigner, so you can start developing screens immediately after CX-Designer starts.

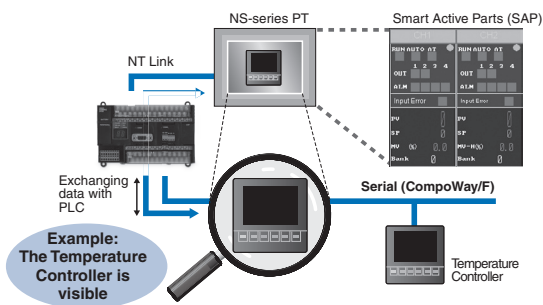

- |                                      |  |
|--------------------------------------|--|
| 1 Network Software                   | CX-Integrator<br>CX-Protocol<br>CX-FLnet                               |
| 2 PLC Software                       | CX-Programmer<br>CX-Simulator<br>SwitchBox                             |
| 3 HMI Software                       | CX-Designer  |
| 4 Motion Controller Software         | CX-Motion<br>CX-Motion-NCF<br>CX-Motion-MCH<br>CX-Position<br>CX-Drive |
| 5 PLC-based Process Control Software | CX-Process Tool<br>NS-series Face Plate Auto-Builder                   |
| 6 Component Software                 | CX-Thermo  |

### • CX-Simulator

Online CPU Unit operations, such as program monitoring, I/O memory manipulation, PV monitoring, forced setting/resetting memory bits, differential monitoring, data tracing, and online editing, can be executed without the actual PLC.

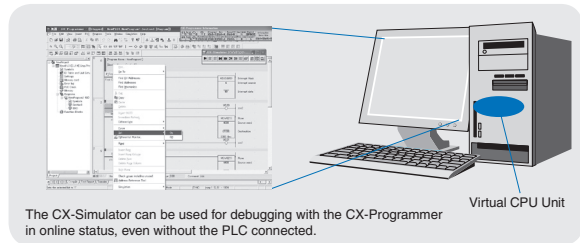

### • CX-Thermo

The Support Software for Temperature Controllers (CX-Thermo) can be started from the CX-Integrator's Serial Communications (CompoWay/F) network.

Parameters can be created, edited, and transferred at the computer. The time required to make settings can be reduced when setting the same parameters in multiple devices.

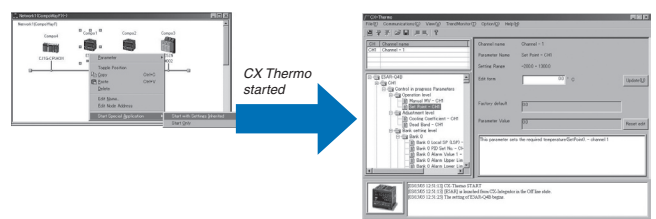

# Handy built-in functions make maintenance easier

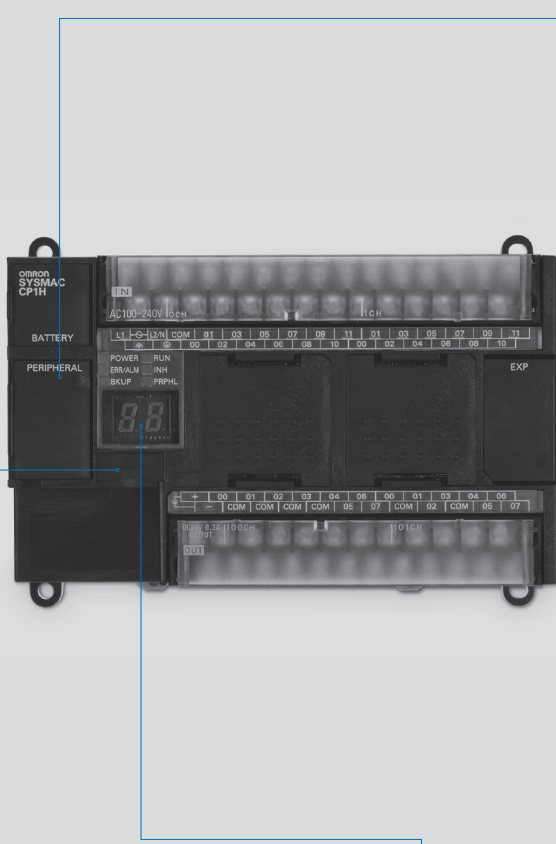

## 1 Analogue Inputs Are Made Simple

An analogue control setting and an analogue input are provided.

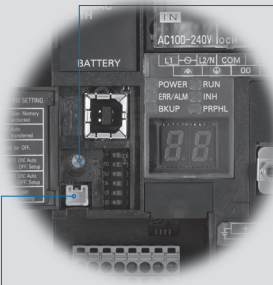

### Analogue setting

The analogue control setting has a resolution of 256 steps.

When the value is changed it is displayed (hexadecimal) for three seconds on the 7-segment display.



### Analogue Input

This input has a resolution of 256 steps and is used for an analogue input set of 0 to 10 V. Each CP1H CPU Unit has one of these connectors built in. (The built-in analogue I/O for CP1HXA CPU Units is separate.) A device, such as a potentiometer, can be connected to enable direct manual operation and control from a control panel. The maximum cable length is 3 meters. A connecting cable (1 m) is included with the CPU Unit.

## 2 Memory Cassette

- Data, such as programs and initial memory values, can be stored on a Memory Cassette (optional) and copied to other systems.
- The Memory Cassette can also be used when installing new versions of application programs.

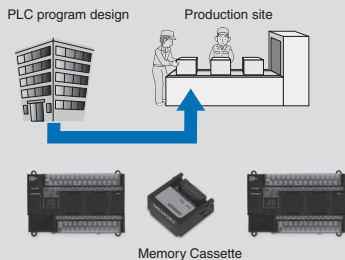

## 3 7-segment Status Display

- The 7-segment Display provides two display digits.
- In addition to displaying error codes for errors detected by the PLC, codes can be displayed on the display from the ladder program.
- The 7-segment display is useful for maintenance as well, allowing problems that arise during system operation to be grasped without using any Support Software.

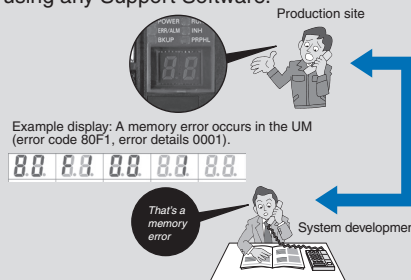

## 4 Battery-free Operation

- The values in the DM Area (32 Kwords) are saved in the CPU Unit's built-in flash memory as initial values, and can be read at startup.
- Battery-free operation is also possible when saving production data and machine parameters in the DM Area, turning OFF the power, and using the same data again for the next production run.

Note:

- A battery is required for the clock function and to retain the status of HR
- Area bits and counter values. A battery is provided as a standard feature with the CPU Unit.
- The user program (ladder program) is stored in built-in flash memory, so no battery is required to back it up.

# Expansion I/O units

Expand as needed

CJ-series Special I/O units and CPU Bus units can be connected

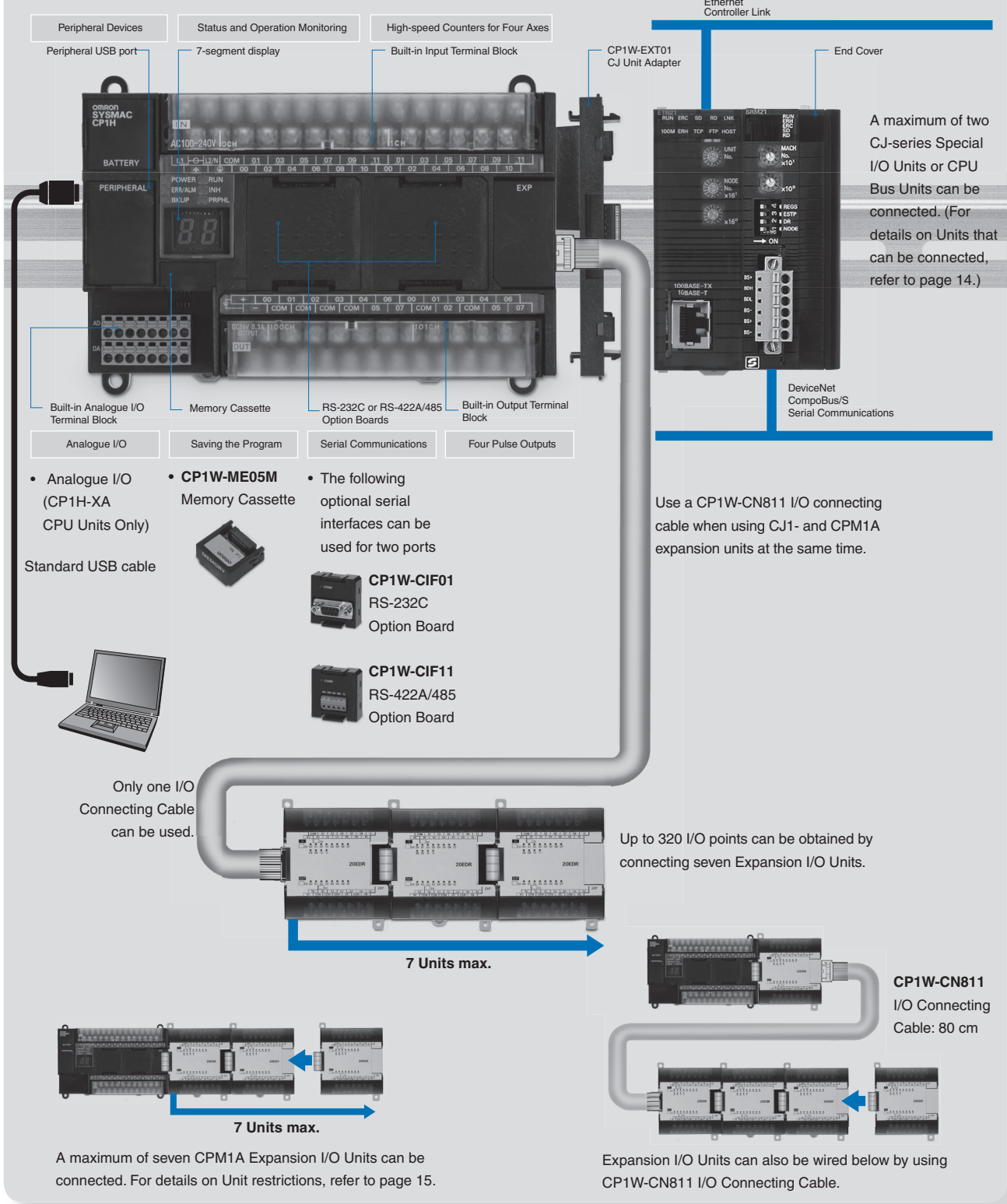

# CPU unit overview

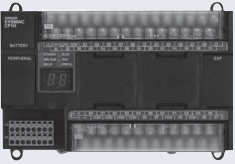
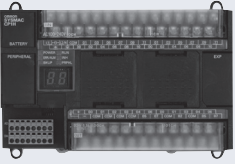
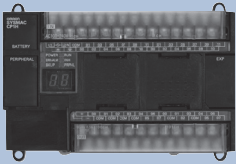
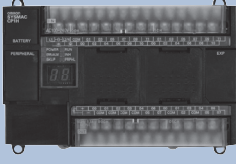
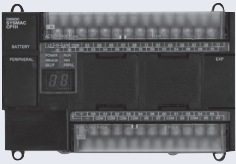
CP1H-XA40D□-□ Built-in Analogue I/O	CP1H-X40D□-□ Basic Model	CP1H-Y20D□-□ High-speed Positioning <i>(To be released soon)</i>
 <p><b>CP1H-XA40DR-A</b> AC power supply, 24 DC inputs, 16 relay outputs, 4 analogue inputs, 2 analogue outputs</p>  <p><b>CP1H-XA40DT-D</b> DC power supply, 24 DC inputs, 16 transistor (sinking) outputs, 4 analogue inputs, 2 analogue outputs</p> <p><b>CP1H-XA40DT1-D</b> DC power supply, 24 DC inputs, 16 transistor (sourcing) outputs, 4 analogue inputs, 2 analogue outputs</p>	 <p><b>CP1H-X40DR-A</b> AC power supply, 24 DC inputs, 16 relay outputs</p>  <p><b>CP1H-X40DT-D</b> DC power supply, 24 DC inputs, 16 transistor (sinking) outputs</p> <p><b>CP1H-X40DT1-D</b> DC power supply, 24 DC inputs, 16 transistor (sourcing) outputs</p>	 <p><b>CP1H-Y20DT-D</b> DC power supply, 12 DC inputs, 8 transistor (sinking) outputs</p> <p>Two 1-MHz line-driver inputs (phases A, B, and Z) and two 1-MHz line-driver outputs (CW and CCW) are provided separately.</p>

	CP1H-XA CPU Units	CP1H-X CPU Units	CP1H-Y CPU Unit
I/O capacity	24 inputs, 16 outputs		12 inputs, 8 outputs Line-driver inputs: Phases A, B, and Z for 2 axes Line-driver outputs: CW and CCW for 2 axes
High-speed counter	100 kHz (single phase), 50 kHz (differential phases), 4 axes		1 MHz (single phase), 500 kHz (differential phases) for 2 axes (line-driver input), 100 kHz (single phase), 50 kHz (differential phases) for 2 axes (4 axes total)
Pulse output function (Models with Transistor Outputs only)	100 kHz for 2 axes and 30 kHz for 2 axes (4 axes total)		1 MHz for 2 axes (line-driver output), 100 kHz for 2 axes (4 axes total)
Serial communications	USB port (peripheral port) and 2 optional serial ports (either RS-232C or RS-422A/485 Option Boards)		
Analogue I/O	4 analogue inputs and 2 analogue outputs	-	-
Interrupt inputs Quick-response inputs (50-ms width min.)	8 inputs		6 inputs
User program capacity	20 kstep		
DM capacity	32 kwords		
Maximum number of CPM1A Expansion I/O Units	7 (Refer to page 16 for Unit restrictions.)		
Maximum number of CJ-series Units	2 (CJ-series Special I/O Units and CPU Bus Units only. Refer to page 14 for information on Units that can be used.)		

• Options

 <p>CP1W-ME05M Memory Cassette</p>	 <p>CP1W-CIF01 RS-232C Option Board</p>	 <p>CP1W-CIF11 RS-422A/485 Option Board</p>
---	--	--

# CP-series expansion units

## • Expansion I/O Units

### CPM1A-8ED

Input points: 8 DC input

### CPM1A-8ER

Output points:  
8 Relay output

### CPM1A-8ET

Output points: 8 Transistor output (sinking)

### CPM1A-8ET1

Output points: 8 Transistor output (sourcing)



### CPM1A-20EDR1

Input points: 12 DC inputs

Output points: 8 relay outputs

### CPM1A-20EDT

Input points: 12 DC inputs

Output points: 8, transistor outputs (sinking)

### CPM1A-20EDT1

Input points: 12 DC inputs

Output points: 8, transistor outputs (sourcing)



### CPM1A-40EDR

Input points: 24 DC inputs

Output points: 16 relay outputs

### CPM1A-40EDT

Input points: 24 DC inputs

Output points: 16 transistor outputs (sinking)

### CPM1A-40EDT1

Input points: 24 DC inputs

Output points: 16 transistor outputs (sourcing)

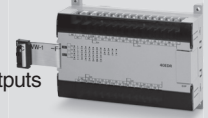

## • Analogue Units



### Analogue Input Unit

#### CPM1A-AD041

Analogue inputs: 4  
(resolution: 6,000)



### Analogue Output Unit

#### CPM1A-DA041

Analogue outputs: 4  
(resolution: 6,000)



### Analogue I/O Unit

#### CPM1A- MAD11

Analogue inputs: 2 (resolution: 6,000)  
Analogue outputs: 1 (resolution: 6,000)



### Analogue I/O Unit

#### CPM1A- MAD01

Analogue inputs: 2 (resolution: 256)  
Analogue outputs: 1 (resolution: 256)

## • Temperature Sensor Units

### CPM1A-TS001

Thermocouple inputs: 2

### CPM1A-TS002

Thermocouple inputs: 4

### CPM1A-TS101

Platinum resistance  
thermometer inputs: 2

### CPM1A-TS102

Platinum resistance  
thermometer inputs: 4

### CPM1A-TS101-DA

Platinum resistance  
thermometer inputs: 2

Analogue output: 1  
(resolution: 256)



## • I/O Connecting

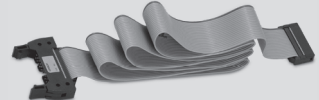

**CP1W-CN811**  
80 cm

## • CompoBus/S - I/O Link Unit

### CPM1A-SRT21

Input points: 8  
Output points: 8



## • DeviceNet I/O Link Unit

### CPM1A-DRT21

Input points: 32  
Output points: 32



## • PROFIBUS-DP I/O Link Unit

### CPM1A-PRT21

Input points: 16  
Output points: 16



## • CJ-series Special I/O Units and CPU Bus Units

Two CJ-series Special I/O Units or CPU Bus Units can be connected by using a CJ Unit Adapter.

### CJ Unit Adapter

#### CP1W-EXT01



### CJ-series Special I/O Units

Analogue Input Unit

#### CJ1W-AD□□□-V1

Analogue Output Unit

#### CJ1W-DA□□□

Analogue I/O Unit

#### CJ1W-MAD42

Process Input Unit

#### CJ1W-PTS□□

Temperature Control Unit

#### CJ1W-TC□□□

CompoBus/S Master Unit

#### CJ1W-SRM21

PROFIBUS-DP Slave Unit

#### CJ1W-PRT21



### CJ-series CPU Bus Units

Ethernet Unit

#### CJ1W-ETN21

Controller Link Unit

#### CJ1W-CLK21-V1

Serial Communications Unit

#### CJ1W-SCU□□-V1

DeviceNet Unit

#### CJ1W-DRM21

PROFIBUS-DP Master Unit

#### CJ1W-PRM21

CAN unit

#### CJ1W-CORT21



System configuration

A maximum of seven CPM1A Expansion I/O Units can be connected.

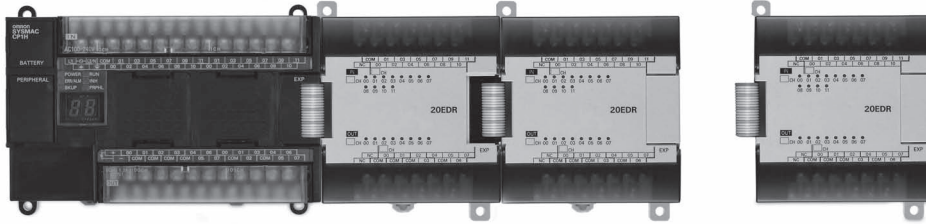

Group A

Unit type		Model
Expansion I/O Units	40 I/O points	CPM1A-40EDR
		CPM1A-40EDT
		CPM1A-40EDT1
	20 I/O points	CPM1A-20EDR1
		CPM1A-20EDT
		CPM1A-20EDT1
	8 inputs	CPM1A-8ED
8 outputs	CPM1A-8ER	
	CPM1A-8ET	
	CPM1A-8ET1	
Analogue Unit	2 analogue inputs, 1 analogue output	CPM1A-MAD01
		CPM1A-MAD11
Temperature Sensor Units	2 thermocouple inputs	CPM1A-TS001
	2 platinum resistance thermometer inputs	CPM1A-TS101
	2 platinum resistance thermometer inputs, 1 analogue output	CPM1A-TS101-DA
CompoBus/S I/O Link Unit	8 inputs, 8 outputs	CPM1A-SRT21
DeviceNet I/O Link Unit	32 inputs, 32 outputs	CPM1A-DRT21
PROFIBUS-DP I/O Link Unit	16 inputs, 16 outputs	CPM1A-PRT21

Group B Units that each count as two units

Unit type		Model
Analogue Units	4 analogue inputs	CPM1A-AD041
	4 analogue outputs	CPM1A-DA041
Temperature Sensor Units	4 thermocouple inputs	CPM1A-TS002
	4 platinum resistance thermometer inputs	CPM1A-TS102

CJ-series Special I/O Units and CPU Bus Units

A maximum of two CJ-series Special I/O Units or CPU Bus Units can be connected by using a CP1W-EXT01 CJ Unit Adapter.

CJ-series Special I/O Units				CJ-series CPU Bus Units	
Unit name	Model	Unit name	Model	Unit name	Model
Analogue Input Units	CJ1W-AD081-V1	Process Input Units	CJ1W-PDC15	Serial Communications Units	CJ1W-SCU41-V1
	CJ1W-AD041-V1		CJ1W-TC001		CJ1W-SCU21-V1
Analogue Output Units	CJ1W-DA08V	Temperature Control Units	CJ1W-TC002	Ethernet Unit	CJ1W-ETN21
	CJ1W-DA08C		CJ1W-TC003	DeviceNet Unit	CJ1W-DRM21
	CJ1W-DA041		CJ1W-TC004	Controller Link Unit	CJ1W-CLK21-V1
	CJ1W-DA021		CJ1W-TC101	PROFIBUS-DP Master Unit	CJ1W-PRM21
Analogue I/O Unit	CJ1W-MAD42	CJ1W-TC102	CAN Unit	CJ1W-CORT21	
Process Input Units	CJ1W-PTS51	CJ1W-TC103			
	CJ1W-PTS52	CJ1W-TC104			
	CJ1W-PTS15	CompoBus/S Master Unit	CJ1W-SRM21		
	CJ1W-PTS16	PROFIBUS-DP Slave Unit	CJ1W-PRT21		

Specifications



CPU Unit Specifications

Item	AC power supply models: CP1H-□□□-A	DC power supply models: CP1H-□□□-D
Power Supply	100 to 240 VAC 50/60 Hz	24 VDC
Operating voltage range	85 to 264 VAC	20.4 to 26.4 VDC (21.6 to 26.4 VDC with four or more Expansion Units.)
Power consumption	Can be used for backing up programs or auto-booting.	50 W max.
Inrush current	100 to 120 VAC inputs: 20 A max. 8 ms max./200 to 240 VAC inputs: 40 A max. 8 ms max.	30 A max. 20 ms max.
External power supply	300 mA at 24 VDC	None
Insulation resistance	20 MΩmin. (at 500 VDC) between the external AC terminals and GR terminals	20 MΩmin. (at 500 VDC) between the external DC terminals and GR terminals
Dielectric strength	2,300 VAC at 50/60 Hz for 1 min between the external AC and GR terminals, leakage current: 5 mA max.	1,000 VAC at 50/60 Hz for 1 min between the external DC and GR terminals, leakage current: 5 mA max.
Noise immunity	Conforming to IEC 61000-4-4. 2 kV (power supply line)	
Vibration resistance	10 to 57 Hz, 0.075-mm amplitude, 57 to 150 Hz, acceleration: 9.8 m/s <sup>2</sup> in X, Y, and Z directions for 80 minutes each (Sweep time: 8 minutes x 10 sweeps = total time 80 minutes)	
Shock resistance	147 m/s <sup>2</sup> , three times each in X, Y, and Z directions	
Ambient operating temperature	0 to 55°C	
Ambient humidity	10% to 90% (with no condensation)	
Ambient operating environment	No corrosive gas	
Ambient storage temperature	-20 to 75°C (Excluding battery.)	
Power holding time	10 ms min.	2 ms min.
Dimensions	150 x 90 x 85 mm (W x H x D)	
Weight	740 g max.	

Item	XA CPU Units: CP1H-XA□□□-□	X CPU Units: CP1H-X□□□-□	Y CPU Units: CP1H-Y□□□-□
Control method	Stored program method		
I/O control method	Cyclic scan with immediate refreshing		
Program language	Ladder diagram		
Function blocks	Maximum number of function block definitions: 128 Maximum number of instances: 256 Languages usable in function block definitions: Ladder diagrams, structured text (ST)		
Instruction length	1 to 7 steps per instruction		
Instructions	Approx. 400 (function codes: 3 digits)		
Instruction execution time	Basic instructions: 0.10 μs min. Special instructions: 0.15 μs min.		
Common processing time	0.7 ms		
Program capacity	20 Ksteps		
Number of tasks	288 (32 cyclic tasks and 256 interrupt tasks) Scheduled interrupt tasks: 1 (interrupt task No. 2, fixed) Input interrupt tasks: 8 (interrupt task No. 140 to 147, fixed), 6 for Y CPU Units High-speed counter interrupt tasks: 256 (interrupt task No. 0 to 255)		
Maximum subroutine number	256		
Maximum jump number	256		
I/O areas	Input bits	1,600 bits (100 words): CIO 0.00 to CIO 99.15 (The 24 built-in inputs are allocated in CIO 0.00 to CIO 0.11 and CIO 1.00 to CIO 1.11.)	
	Output bits	1,600 bits (100 words): CIO 100.00 to CIO 199.15 (The 16 built-in outputs are allocated in CIO 100.00 to CIO 100.07 and CIO 101.00 to CIO 101.07.)	
	Built-in Analog Inputs	CIO 200 to CIO 203	
	Built-in Analog Outputs	CIO 210 to CIO 211	
	Serial PLC Link Area	1,440 bits (90 words): CIO 3100.00 to CIO 3189.15 (CIO 3100 to CIO 3189)	
Work bits	8,192 bits (512 words): W000.00 to W511.15 (W0 to W511) 37,504 bits (2,344 words): CIO 3800.00 to CIO 6143.15 (CIO 3800 to CIO 6143)		
TR Area	16 bits: TR0 to TR15		
Holding Area	8,192 bits (512 words): H0.00 to H511.15 (H0 to H511)		
AR Area	Read-only (Write-prohibited): 7168 bits (448 words): A0.00 to A447.15 (A0 to A447) Read/Write: 8192 bits (512 words): A448.00 to A959.15 (A448 to A959)		
Timers	4,096 bits: T0 to T4095		
Counters	4,096 bits: C0 to C4095		
DM Area (See note.)	32 Kwords: D0 to D32767		
Data Register Area	16 registers (16 bits): DR0 to DR15		
Index Register Area	6 registers (16 bits): IR0 to IR15		
Task Flag Area	32 flags (32 bits): TK0000 to TK0031		
Trace Memory	4,000 words (500 samples for the trace data maximum of 31 bits and 6 words.)		
Memory Cassette	A special Memory Cassette (CP1W-ME05M) can be mounted. Note: Can be used for program backups and auto-booting.		
Clock function	Supported. Accuracy (monthly deviation): -3.5 min to -0.5 min (ambient temperature: 55°C), -1.5 min to +1.5 min (ambient temperature: 25°C), -3 min to +1 min (ambient temperature: 0°C)		
Communications functions	One built-in peripheral port (USB1.1): For connecting Support Software only. A maximum of two Serial Communications Option Boards can be mounted.		
Memory backup	Flash memory: User programs, parameters (such as the PLC Setup), comment data, and the entire DM Area can be saved to flash memory as initial values. Battery backup: The Holding Area, DM Area, and counter values (flags, PV) are backed up by a battery.		
Battery service life	5 years at 25 °C. (Use the replacement battery within two years of manufacture.)		
Built-in input terminals	40 (24 inputs, 16 outputs)	20 (12 inputs, 8 outputs) Line-driver inputs: Two axes for phases A, B, and Z Line-driver outputs: Two axes for CW and CCW	
Number of connectable Expansion (I/O) Units	CPM1A Expansion I/O Units: 7 max.; CJ-series Special I/O Units or CPU Bus Units: 2 max.		
Max. number of I/O points	320 (40 built in + 40 per Expansion (I/O) Unit x 7 Units)		300 (20 built in + 40 per Expansion (I/O) Unit x 7 Units)

Item	XA CPU Units: CP1H-XA□□□-□	X CPU Units: CP1H-X□□□□-□	Y CPU Units: CP1H-Y□□□□-□
Interrupt inputs	8 inputs (Shared by the external interrupt inputs (counter mode) and the quick-response inputs.)		6 inputs (Shared by the external interrupt inputs (counter mode) and the quick-response inputs.)
Interrupt inputs counter mode	8 inputs (Response frequency: 5 kHz max. for all interrupt inputs), 16 bits		6 inputs (Response frequency: 5 kHz max. for all interrupt inputs), 16 bits
Quick-response inputs	8 points (Min. input pulse width: 50 $\mu$ s max.)		6 points (Min. input pulse width: 50 $\mu$ s max.)
Scheduled interrupts	1		
High-speed counters	4 inputs: Differential phases (4x), 50 kHz or single phase (pulse plus direction, up/down, increment), Value range: 32 bits, Linear mode or ring mode Interrupts: Target value comparison or range comparison		2 inputs: Differential phases (4x), 500 kHz or single phase, 1 MHz and 2 inputs: Differential phases (4x), 50 kHz or single phase (pulse plus direction, up/down, increment), 100 kHz Value range: 32 bits, Linear mode or ring mode Interrupts: Target value comparison or range comparison
Pulse outputs (models with transistor outputs only)	Trapezoidal or S-curve acceleration and deceleration (Duty ratio: 50% fi xed) 2 outputs, 1 Hz to 100 kHz (CCW/CW or pulse plus direction) 2 outputs, 1 Hz to 30 kHz (CCW/CW or pulse plus direction) PWM outputs : (Duty ratio: 0.0% to 100.0% (Unit: 0.1%)) 2 outputs, 0.1 to 1 kHz (Accuracy: $\pm$ 5% at 1 kHz)		Trapezoidal or S-curve acceleration and deceleration (Duty ratio: 50% fi xed) 2 outputs, 1 Hz to 1 MHz (CCW/CW or pulse plus direction) 2 outputs, 1 Hz to 100 kHz (CCW/CW or pulse plus direction) PWM outputs : (Duty ratio: 0.0% to 100.0% (Unit: 0.1%)) 2 outputs, 0.1 to 1 kHz (Accuracy: $\pm$ 5% at 1 kHz)
Built-in analog I/O terminals	4 analogue inputs and 2 analogue outputs (Refer to separate detailed specifications.)	None	
Analogue control	1 (Setting range: 0 to 255)		
External analogue input	1 input (Resolution: 1/256, Input range: 0 to 10 V)		

**Serial Communications Specifications**

Item	Function	Interface
Peripheral USB port	For connecting Peripheral Device.	Conforms to USB 1.1, B-type connector
Serial port 1	Host Link, No-protocol, NT Link (1: N), Serial PLC Link (See note.), Serial Gateway (CompoWay/F master, Modbus-RTU master), Modbus-RTU easy master function	The CP1W-CIF01 RS-232C Option Board 
Serial port 2	Host Link, No-protocol, NT Link (1: N), Serial PLC Link (See note.), Serial Gateway (CompoWay/F master, Modbus-RTU master), Modbus-RTU easy master function	or the CP1W-CIF11 RS-422A/485 Option Board   can be used with either port.

**Analogue I/O Specifications (CP1H-XA CPU Units Only)**

Item		Voltage I/O	Current I/O
Analogue Input Section	Number of analog inputs	4	
	Input signal range	0 to 5 V, 1 to 5 V, 0 to 10 V, or -10 to 10 V	
	Max. rated input	$\pm$ 15 V	
	External input impedance	1 M $\Omega$ min.	
	Resolution	1/6,000 or 1/12,000 (full scale)	
	Overall accuracy	25 °C: $\pm$ 0.3% full scale/0 to 55 °C: $\pm$ 0.6% full scale	25 °C: $\pm$ 0.4% full scale/0 to 55 °C: $\pm$ 0.8% full scale
	A/D conversion data	Full scale for -10 to 10 V: F448 (E890) to 0BB8 (1770) Hex Full scale for other ranges: 0000 to 1770 (2EE0) Hex	
	Averaging	Supported (Set for individual inputs in the PLC Setup.)	
Analogue Output Section	Open-circuit detection	Supported (Value when disconnected: 8000 Hex)	
	Number of outputs	2 outputs	
	Output signal range	0 to 5 V, 1 to 5 V, 0 to 10 V, or -10 to 10 V	
	Allowable external output load resistance	1 k $\Omega$ min.	
	External output impedance	0.5 max.	
	Resolution	1/6,000 or 1/12,000 (full scale)	
	Overall accuracy	25 °C: $\pm$ 0.4% full scale/0 to 55 °C: $\pm$ 0.8% full scale	
	D/A conversion data	Full scale for -10 to 10 V: F448 (E890) to 0BB8 (1770) hex Full scale for other ranges: 0000 to 1770 (2EE0) hex	
Conversion time	1 ms/point		
Isolation method	Photocoupler isolation between analogue I/O terminals and internal circuits. No isolation between analogue I/O signals.		

Dimensions CP1H CPU Units

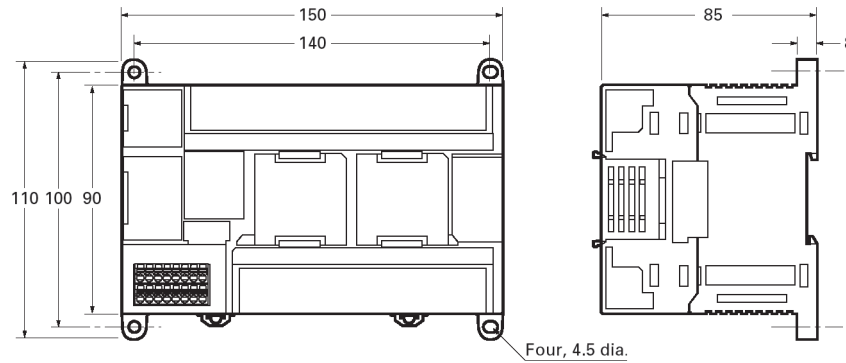

Ordering Information

CPU Units

CPU Unit	Specifications				Model	Standards
	Power Supply	Output method	Inputs	Outputs		
CP1H-X CPU Units Memory capacity: 20 Ksteps High-speed counters: 100 kHz, 4 axes Pulse outputs: 100 kHz, 2 axes 30 kHz, 2 axes	AC	Relay	24	16	CP1H-X40DR-A	CE, N
	DC	Transistor (sinking)			CP1H-X40DT-D	CE, N
		Transistor (sourcing)			CP1H-X40DT1-D	CE, N
CP1H-XA CPU Units Memory capacity: 20 Ksteps High-speed counters: 100 kHz, 4 axes Pulse outputs: 100 Hz, 2 axes 30 kHz, 2 axes Analogue inputs: 4 Analogue outputs: 2	AC	Relay	24	16	CP1H-XA40DR-A	CE, N
	DC	Transistor (sinking)			CP1H-XA40DT-D	CE, N
		Transistor(sourcing)			CP1H-XA40DT1-D	CE, N
CP1H-Y CPU Units Memory capacity: 20 Ksteps High-speed counters: 1 MHz, 2 axes 100 kHz, 2 axes Pulse outputs: 1 MHz, 2 axes 30 kHz, 2 axes	DC	Transistor (sinking)	12+line-driver input, 2 axes	8 +line-driver input, 2 axes	CP1H-Y20DT-D (To be released soon.)	-

Options (for CPU Units)

Name	Specifications	Model	Standards
RS-232C Option Board	For CPU Unit option port.	CP1W-CIF01	CE, N
RS-422A/485 Option Board	For CPU Unit option port.	CP1W-CIF11	CE, N
Memory Cassette	Can be used for backing up programs or auto-booting.	CP1W-ME05M	CE, N

Maintenance Products

Name	Specifications	Model	Standards
Battery Set	For CP1H CPU Units (Use batteries within two years of manufacture.)	CJ1W-BAT01	CE
DIN Track	Length: 0.5 m; Height: 7.3 mm	PFP-50N	
	Length: 1 m; Height: 7.3 mm	PFP-100N	
	Length: 1 m; Height: 16 mm	PFP-100N2	
	End Plate	There are 2 stoppers provided with CPU Units and I/O Interface Units as standard accessories to secure the Units on the DIN Track.	PFP-M

I/O Connecting Cable

Name	Specifications	Model	Standards
I/O Connecting Cable	80 cm (for CPM1A Expansion Units)	CP1W-CN811	CE, N

Programming Devices

Name	Specifications		Model	Standards
CX-One FA Integrated Tool Package	CX-One is a package that integrates the Support Software for OMRON PLCs and components. CX-One runs on the following OS. OS: Windows 98SE, Me, NT 4.0 (Service Pack 6a), 2000 (Service Pack 3 or higher), or XP. CX-One includes CX-Programmer Ver.6.0 and CX-Simulator Ver.1.0. For details, refer to the CX-One catalog (Cat. No. R134). For CPU Unit option port. Can be used for backing up programs or auto-booting.	One license	CXONE-AL01C-E	-
		Three licenses	CXONE-AL03C-E	-
		Ten licenses	CXONE-AL10C-E	-
Computer Connecting Cable for CP1W-CIF01 RS-232C Option Board (See note.)  USB-Serial Conversion Cable <sup>*1</sup>	D-Sub 9-pin (Length: 2.0 m)	For anti-static connectors	XW2Z-200S-CV	-
	D-Sub 9-pin (Length: 5.0 m)		XW2Z-500S-CV	-
	D-Sub 9-pin (Length: 2.0 m)	XW2Z-200S-V	-	
	D-Sub 9-pin (Length: 5.0 m)	XW2Z-500S-V	-	
	USB-RS-232C Conversion Cable (Length: 0.5 m) and PC Complies with USB Specification 1.1 On personal computer side: USB (A plug connector, male) On PLC side: RS-232C (D-sub 9-pin, male) Driver: Supported by Windows 98, Me, 2000, and XP		CS1W-CIF31	-

\*1 Cannot be used with a peripheral USB port. To connect to a personal computer via a peripheral USB port, use commercially-available USB cable (A to B type, male).

Technical Documentation

Name	Standards
CP1H CPU Unit Operation Manual	W450-E1
CP1H CPU Unit Programming Manual	W451-E1

Expansion Units

Name	Output method	Input	Output	Model	Standard
Expansion I/O Units	Relay	24	16	CPM1A-40EDR	CE, N
	Transistor (sinking)			CPM1A-40EDT	CE, N
	Transistor output (sourcing)			CPM1A-40EDT1	CE, N
	Relay	12	8	CPM1A-20EDR1	U, C, CE
	Transistor (sinking)			CPM1A-20EDT	U, C, N, CE
	Transistor output (sourcing)			CPM1A-20EDT1	U, C, N, CE
	-	8	-	CPM1A-8ED	U, C, N, CE
	Relay	-	8	CPM1A-8ER	U, C, N, CE
Transistor (sinking)	-	8	CPM1A-8ET	U, C, N, CE	
Transistor output (sourcing)	-	-	CPM1A-8ET1	U, C, N, CE	
Analogue Input Unit	Analogue (resolution: 1/6000)	4	-	CPM1A-AD041	U, C, N, CE
Analogue Output Unit	Analogue (resolution: 1/6000)	-	4	CPM1A-DA041	UC1, CE
Analogue I/O Units	Analogue (resolution: 1/256)	2	1	CPM1A-MAD01	UC1, CE
	Analogue (resolution: 1/6000)	2	1	CPM1A-MAD11	U, C, N, CE
DeviceNet I/O Link Unit	-	32 (I/O link bits)	32 (I/O link bits)	CPM1A-DRT21	U, C, CE
CompoBus/S I/O Link Unit	-	8 (I/O link bits)	8 (I/O link bits)	CPM1A-SRT21	U, C, N, CE
PROFIBUS-DP I/O Link Unit	-	16 (I/O link bits)	16 (I/O link bits)	CPM1A-PRT21	CE
Temperature Sensor Units	2 thermocouple inputs			CPM1A-TS001	U, C, N, CE
	4 thermocouple inputs			CPM1A-TS002	U, C, N, CE
	2 platinum resistance thermometer inputs			CPM1A-TS101	U, C, N, CE
	4 platinum resistance thermometer inputs			CPM1A-TS102	U, C, N, CE
	2 platinum resistance thermometer inputs, 1 Analogue output (resolution: 256)			CPM1A-TS101-DA	U, C, L, CE

**CJ-series Special I/O Units and CPU Bus Units**

Category	Name	Specifications	Model	Standard
CP1H CPU Unit options	CJ Unit Adapter	Adapter for connecting CJ-series Special I/O Units and CPU Bus Units (includes CJ-series End Cover)	CP1W-EXT01	UC1, CE, N, L
CJ-series Special I/O Units	Analogue Input Units	8 inputs (1 to 5 V, 0 to 5 V, 0 to 10 V, -10 to 10 V, 4 to 20 mA) Resolution: 1/8,000; Conversion speed: 250 is/input max. (Can be set to 1/4,000 resolution and 1 ms/input.)	CJ1W-AD081-V1	UC1, CE, N, L
		4 inputs (1 to 5 V, 0 to 5 V, 0 to 10 V, -10 to 10 V, 4 to 20 mA) Resolution: 1/8,000; Conversion speed: 250 is/input max. (Can be set to 1/4,000 resolution and 1 ms/input.)	CJ1W-AD041-V1	
	Analogue Output Units	8 outputs (1 to 5 V, 0 to 5 V, 0 to 10 V, -10 to 10 V) Resolution: 1/4,000; Conversion speed: 1 ms/output max. (Can be set to 1/8000, 250 is/output)	CJ1W-DA08V	UC1, CE, N, L
		8 outputs (4 to 20 mA) Resolution: 1/4,000; Conversion speed: 1 ms/output max. (Can be set to 1/8,000, 250 is/output)	CJ1W-DA08C	
		4 outputs (1 to 5 V, 0 to 5 V, 0 to 10 V, -10 to 10 V, 4 to 20 mA) Resolution: 1/4,000, Conversion speed: 1 ms/point max.	CJ1W-DA041	
		2 outputs (1 to 5 V, 0 to 5 V, 0 to 10 V, -10 to 10 V, 4 to 20 mA) Resolution: 1/4,000; Conversion speed: 1 ms/output max.	CJ1W-DA021	
	Analogue I/O Unit	4 inputs, 2 outputs (1 to 5 V, 0 to 5 V, 0 to 10 V, -10 to 10 V, 4 to 20 mA) Resolution: 1/4000; Conversion speed: 1 ms/point max. (Can be set to 1/8,000, 250 is/point)	CJ1W-MAD42	
	Process Input Units	4 inputs, B, J, K, L, R, S, T; Conversion speed: 250 ms/4 inputs	CJ1W-PTS51	UC1, CE
		4 inputs, Pt100 U (JIS, IEC), JPt100 U, Conversion speed: 250 ms/4 inputs	CJ1W-PTS52	
		2 inputs, B, E, J, K, L, N, R, S, T, U, W, Re5-26, PL ±100 mV, Resolution: 1/64,000; Conversion speed: 10 ms/2 inputs	CJ1W-PTS15	
		2 inputs, Pt100, JPt100, Pt50, Ni508.4; Resolution: 1/64,000; Conversion speed: 10 ms/2 inputs	CJ1W-PTS16	
		2 inputs, 0 to 1.25 V, -1.25 to 1.25 V, 0 to 5 V, 1 to 5 V, -5 to 5 V, 0 to 10 V, -10 to 10V, ±10 V selectable range, 0 to 20 mA, 4 to 20 mA	CJ1W-PDC15	
	Temperature Control Units	4 loops, thermocouple input, NPN output	CJ1W-TC001	UC1, CE, N, L
		4 loops, thermocouple input, PNP output	CJ1W-TC002	
		2 loops, thermocouple input, NPN output, heater burnout detection function	CJ1W-TC003	
		2 loops, thermocouple input, PNP output, heater burnout detection function	CJ1W-TC004	
		4 loops, platinum resistance thermometer input, NPN output	CJ1W-TC101	
		4 loops, platinum resistance thermometer input, PNP output	CJ1W-TC102	
		22 loops, platinum resistance thermometer input, NPN output, heater burnout detection function	CJ1W-TC103	
		2 loops, platinum resistance thermometer input, PNP output, heater burnout detection function	CJ1W-TC104	
CompoBus/S Master Unit	CompoBus/S remote I/O, 256 points max.	CJ1W-SRM21		
PROFIBUS-DP Slave Unit	Exchanges up to 180 words in any memory area with a PROFIBUS-DP Master Unit	CJ1W-PRT21	UC, CE	
CJ-series CPU Bus Units	Controller Link Units	Wired (Shielded twisted-pair cable)	CJ1W-CLK21-V1	UC1, CE, N, L
	Serial Communications Units	1 RS-232C port and 1 RS-422A/485 port	CJ1W-SCU41-V1	
		2 RS-232C ports	CJ1W-SCU21-V1	
	Ethernet Unit	100Base-TX	CJ1W-ETN21	
	DeviceNet Unit	Functions as master and/or slave; allows control of 32,000 points max. per master.	CJ1W-DRM21	
	PROFIBUS-DP Master Unit	Controls up to 7000 words of remote I/O data over PROFIBUS-DP	CJ1W-PRM21	
CAN Unit	Can send and/or receive any CAN-Message	CJ1W-CORT21	CE	

# Terms and Conditions of Sale

- Offer; Acceptance.** These terms and conditions (these "Terms") are deemed part of all quotes, agreements, purchase orders, acknowledgments, price lists, catalogs, manuals, brochures and other documents, whether electronic or in writing, relating to the sale of products or services (collectively, the "Products") by Omron Electronics LLC and its subsidiary companies ("Omron"). Omron objects to any terms or conditions proposed in Buyer's purchase order or other documents which are inconsistent with, or in addition to, these Terms.
- Prices; Payment Terms.** All prices stated are current, subject to change without notice by Omron. Omron reserves the right to increase or decrease prices on any unshipped portions of outstanding orders. Payments for Products are due net 30 days unless otherwise stated in the invoice.
- Discounts.** Cash discounts, if any, will apply only on the net amount of invoices sent to Buyer after deducting transportation charges, taxes and duties, and will be allowed only if (i) the invoice is paid according to Omron's payment terms and (ii) Buyer has no past due amounts.
- Interest.** Omron, at its option, may charge Buyer 1-1/2% interest per month or the maximum legal rate, whichever is less, on any balance not paid within the stated terms.
- Orders.** Omron will accept no order less than \$200 net billing.
- Governmental Approvals.** Buyer shall be responsible for, and shall bear all costs involved in, obtaining any government approvals required for the importation or sale of the Products.
- Taxes.** All taxes, duties and other governmental charges (other than general real property and income taxes), including any interest or penalties thereon, imposed directly or indirectly on Omron or required to be collected directly or indirectly by Omron for the manufacture, production, sale, delivery, importation, consumption or use of the Products sold hereunder (including customs duties and sales, excise, use, turnover and license taxes) shall be charged to and remitted by Buyer to Omron.
- Financial.** If the financial position of Buyer at any time becomes unsatisfactory to Omron, Omron reserves the right to stop shipments or require satisfactory security or payment in advance. If Buyer fails to make payment or otherwise comply with these Terms or any related agreement, Omron may (without liability and in addition to other remedies) cancel any unshipped portion of Products sold hereunder and stop any Products in transit until Buyer pays all amounts, including amounts payable hereunder, whether or not then due, which are owing to it by Buyer. Buyer shall in any event remain liable for all unpaid accounts.
- Cancellation; Etc.** Orders are not subject to rescheduling or cancellation unless Buyer indemnifies Omron against all related costs or expenses.
- Force Majeure.** Omron shall not be liable for any delay or failure in delivery resulting from causes beyond its control, including earthquakes, fires, floods, strikes or other labor disputes, shortage of labor or materials, accidents to machinery, acts of sabotage, riots, delay in or lack of transportation or the requirements of any government authority.
- Shipping; Delivery.** Unless otherwise expressly agreed in writing by Omron:
  - Shipments shall be by a carrier selected by Omron; Omron will not drop ship except in "break down" situations.
  - Such carrier shall act as the agent of Buyer and delivery to such carrier shall constitute delivery to Buyer;
  - All sales and shipments of Products shall be FOB shipping point (unless otherwise stated in writing by Omron), at which point title and risk of loss shall pass from Omron to Buyer; provided that Omron shall retain a security interest in the Products until the full purchase price is paid;
  - Delivery and shipping dates are estimates only; and
  - Omron will package Products as it deems proper for protection against normal handling and extra charges apply to special conditions.
- Claims.** Any claim by Buyer against Omron for shortage or damage to the Products occurring before delivery to the carrier must be presented in writing to Omron within 30 days of receipt of shipment and include the original transportation bill signed by the carrier noting that the carrier received the Products from Omron in the condition claimed.
- Warranties.** (a) **Exclusive Warranty.** Omron's exclusive warranty is that the Products will be free from defects in materials and workmanship for a period of twelve months from the date of sale by Omron (or such other period expressed in writing by Omron). Omron disclaims all other warranties, express or implied. (b) **Limitations.** OMRON MAKES NO WARRANTY OR REPRESENTATION, EXPRESS OR IMPLIED, ABOUT NON-INFRINGEMENT, MERCHANTABILITY OR FITNESS FOR A PARTICULAR PURPOSE OF THE PRODUCTS. BUYER ACKNOWLEDGES THAT IT ALONE HAS DETERMINED THAT THE PRODUCTS WILL SUITABLY MEET THE REQUIREMENTS OF THEIR INTENDED USE. Omron further disclaims all warranties and responsibility of any type for claims or expenses based on infringement by the Products or otherwise of any intellectual property right. (c) **Buyer Remedy.** Omron's sole obligation hereunder shall be, at Omron's election, to (i) replace (in the form originally shipped with Buyer responsible for labor charges for removal or replacement thereof) the non-complying Product, (ii) repair the non-complying Product, or (iii) repay or credit Buyer an amount equal to the purchase price of the non-complying Product; provided that in no event shall Omron be responsible for warranty, repair, indemnity or any other claims or expenses regarding the Products unless Omron's analysis confirms that the Products were properly handled, stored, installed and maintained and not subject to contamination, abuse, misuse or inappropriate modification. Return of any Products by Buyer must be approved in writing by Omron before shipment. Omron Companies shall not be liable for the suitability or unsuitability or the results from the use of Products in combination with any electrical or electronic components, circuits, system assemblies or any other materials or substances or environments. Any advice, recommendations or information given orally or in writing, are not to be construed as an amendment or addition to the above warranty. See <http://www.omron247.com> or contact your Omron representative for published information.
- Limitation on Liability; Etc.** OMRON COMPANIES SHALL NOT BE LIABLE FOR SPECIAL, INDIRECT, INCIDENTAL, OR CONSEQUENTIAL DAMAGES, LOSS OF PROFITS OR PRODUCTION OR COMMERCIAL LOSS IN ANY WAY CONNECTED WITH THE PRODUCTS, WHETHER SUCH CLAIM IS BASED IN CONTRACT, WARRANTY, NEGLIGENCE OR STRICT LIABILITY. Further, in no event shall liability of Omron Companies exceed the individual price of the Product on which liability is asserted.
- Indemnities.** Buyer shall indemnify and hold harmless Omron Companies and their employees from and against all liabilities, losses, claims, costs and expenses (including attorney's fees and expenses) related to any claim, investigation, litigation or proceeding (whether or not Omron is a party) which arises or is alleged to arise from Buyer's acts or omissions under these Terms or in any way with respect to the Products. Without limiting the foregoing, Buyer (at its own expense) shall indemnify and hold harmless Omron and defend or settle any action brought against such Companies to the extent based on a claim that any Product made to Buyer specifications infringed intellectual property rights of another party.
- Property; Confidentiality.** Any intellectual property in the Products is the exclusive property of Omron Companies and Buyer shall not attempt to duplicate it in any way without the written permission of Omron. Notwithstanding any charges to Buyer for engineering or tooling, all engineering and tooling shall remain the exclusive property of Omron. All information and materials supplied by Omron to Buyer relating to the Products are confidential and proprietary, and Buyer shall limit distribution thereof to its trusted employees and strictly prevent disclosure to any third party.
- Export Controls.** Buyer shall comply with all applicable laws, regulations and licenses regarding (i) export of products or information; (ii) sale of products to "forbidden" or other proscribed persons; and (iii) disclosure to non-citizens of regulated technology or information.
- Miscellaneous.** (a) **Waiver.** No failure or delay by Omron in exercising any right and no course of dealing between Buyer and Omron shall operate as a waiver of rights by Omron. (b) **Assignment.** Buyer may not assign its rights hereunder without Omron's written consent. (c) **Law.** These Terms are governed by the law of the jurisdiction of the home office of the Omron company from which Buyer is purchasing the Products (without regard to conflict of law principles). (d) **Amendment.** These Terms constitute the entire agreement between Buyer and Omron relating to the Products, and no provision may be changed or waived unless in writing signed by the parties. (e) **Severability.** If any provision hereof is rendered ineffective or invalid, such provision shall not invalidate any other provision. (f) **Setoff.** Buyer shall have no right to set off any amounts against the amount owing in respect of this invoice. (g) **Definitions.** As used herein, "including" means "including without limitation"; and "Omron Companies" (or similar words) mean Omron Corporation and any direct or indirect subsidiary or affiliate thereof.

## Certain Precautions on Specifications and Use

- Suitability of Use.** Omron Companies shall not be responsible for conformity with any standards, codes or regulations which apply to the combination of the Product in the Buyer's application or use of the Product. At Buyer's request, Omron will provide applicable third party certification documents identifying ratings and limitations of use which apply to the Product. This information by itself is not sufficient for a complete determination of the suitability of the Product in combination with the end product, machine, system, or other application or use. Buyer shall be solely responsible for determining appropriateness of the particular Product with respect to Buyer's application, product or system. Buyer shall take application responsibility in all cases but the following is a non-exhaustive list of applications for which particular attention must be given:
  - Outdoor use, uses involving potential chemical contamination or electrical interference, or conditions or uses not described in this document.
  - Use in consumer products or any use in significant quantities.
  - Energy control systems, combustion systems, railroad systems, aviation systems, medical equipment, amusement machines, vehicles, safety equipment, and installations subject to separate industry or government regulations.
  - Systems, machines and equipment that could present a risk to life or property. Please know and observe all prohibitions of use applicable to this Product.

NEVER USE THE PRODUCT FOR AN APPLICATION INVOLVING SERIOUS RISK TO LIFE OR PROPERTY OR IN LARGE QUANTITIES WITHOUT ENSURING THAT THE SYSTEM AS A WHOLE HAS BEEN DESIGNED TO ADDRESS THE RISKS, AND THAT THE OMRON'S PRODUCT IS PROPERLY RATED AND INSTALLED FOR THE INTENDED USE WITHIN THE OVERALL EQUIPMENT OR SYSTEM.
- Programmable Products.** Omron Companies shall not be responsible for the user's programming of a programmable Product, or any consequence thereof.
- Performance Data.** Data presented in Omron Company websites, catalogs and other materials is provided as a guide for the user in determining suitability and does not constitute a warranty. It may represent the result of Omron's test conditions, and the user must correlate it to actual application requirements. Actual performance is subject to the Omron's Warranty and Limitations of Liability.
- Change in Specifications.** Product specifications and accessories may be changed at any time based on improvements and other reasons. It is our practice to change part numbers when published ratings or features are changed, or when significant construction changes are made. However, some specifications of the Product may be changed without any notice. When in doubt, special part numbers may be assigned to fix or establish key specifications for your application. Please consult with your Omron's representative at any time to confirm actual specifications of purchased Product.
- Errors and Omissions.** Information presented by Omron Companies has been checked and is believed to be accurate; however, no responsibility is assumed for clerical, typographical or proofreading errors or omissions.

Complete "Terms and Conditions of Sale" for product purchase and use are on Omron's website at [www.omron247.com](http://www.omron247.com) – under the "About Us" tab, in the Legal Matters section.

**ALL DIMENSIONS SHOWN ARE IN MILLIMETERS.**

To convert millimeters into inches, multiply by 0.03937. To convert grams into ounces, multiply by 0.03527.

---

**OMRON**<sup>®</sup>**OMRON ELECTRONICS LLC**

1 Commerce Drive  
Schaumburg, IL 60173  
Tel: 847.843.7900

For U.S. technical support or other inquiries: 800.556.6766

**OMRON CANADA, INC.**

885 Milner Avenue  
Toronto, Ontario M1B 5V8  
Tel: 416.286.6465

**MEXICO SALES OFFICES**

**Mexico, D.F.** 555.660.3144  
**Ciudad Juárez** 656.623.7083  
**Monterrey, N.L.** 818.377.4281  
**Querétaro** 442.135.4510

**BRAZIL SALES OFFICE**

**Sao Paulo** 55.11.2101.6310

**ARGENTINA SALES OFFICE**

**Cono Sur** 54.114.787.1129

**CHILE SALES OFFICE**

**Santiago** 562.206.4592

**OTHER LATIN AMERICAN SALES**

[mela@omron.com](mailto:mela@omron.com)

**OMRON ON-LINE****Global -**

[www.omron.com](http://www.omron.com)

**USA -**

[www.omron247.com](http://www.omron247.com)

**Canada -**

[www.omron.ca](http://www.omron.ca)

**Brazil -**

[www.omron.com.br](http://www.omron.com.br)

**Latin America -**

[www.espanol.omron.com](http://www.espanol.omron.com)