

Color Sensors, Operation

Uses for color sensors

color sensors are becoming increasingly important in the automation of processes and manufacturing lines in industry, particularly the processing industry. In practice, the possibilities for application are virtually unlimited. They range from the identification or sorting of colored objects to the checking of colored surfaces. In many cases, color as a detection criterion is already integrated in the objects being handled; if not, color can simply be added.

Color determination and perception

The most visible criteria for describing a color are the attributes hue and chroma (qualitative) and luminance (quantitative). Hue basically determines how a color is perceived; i.e. as red, green, yellow, etc. Chroma defines how matte and weak or how full and bright a color is, or in other words how close a color is to grey or the pure hue. The third basic property of a color is luminance, i.e. its intensity which determines whether a color is described as light or dark.

For human beings, color is a matter of subjective perception.

When light enters the eye of a person with normal color perception, this process is triggered automatically.

The perception of color is influenced by the following factors:

- light (illumination)
- the surface of the material
- subjective color perception

Instrumental color determination

color values can be determined with instruments using either real color measuring devices or comparative, integral measuring methods. However, color measuring devices, which determine pure color values, are very slow, expensive, and unsuitable for use in industrial environments. In contrast, comparative, integral measuring methods are also suitable for fast on-line color determination in automation technology where the color of an object is compared with a previously measured reference value (product sample).

Mode of operation

The color sensors CS 1 and CS 3 function according to a special three-color method and can be integrated in any production line.

The test object is illuminated using light of different spectral composition. The reflected light radiation is collected, digitised, and standardised using microprocessors. A special process has been developed for this procedure. The measured values are compared with previously stored references color values. If the values are within the defined tolerance range, a switching output is activated.

Areas of application

The sensor is an extremely compact and multi-functional measuring system which can be used for the color detection of both opaque objects in reflected light and transparent materials in transmitted light. Consequently, the system is suitable for the automation of all industrial processes for which the color of an object is a criterion for recognition or segmentation.

Setting / operation

In order to simplify setting and operation of the device, the reference color is programmed using the teach-in method. The reference object (product sample) is simply placed at the required scanning distance, the desired color selectivity (slight color nuances to color families) is set using a rotary switch, and the programming process is started by pressing the Teach button on the sensor. Completion of the teach process is indicated by an LED. Alternatively, to allow manual programming, reference colors can also be stored using a PLC via the External Teach (ET) input line.

Color Sensors

CS 1

CS 3

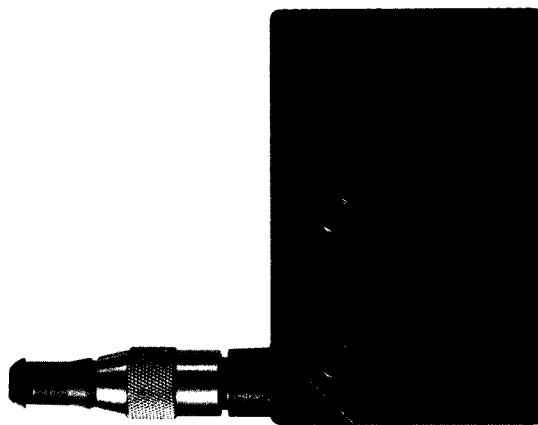

**TW 12.5 and 60 mm
RW 50 to 1000 mm**



**TW 12.5 and 60 mm
RW 50 to 1000 mm**



Color sensors that function according to a special three-color method.

Suitable for the color recognition of both opaque objects in reflected light and transparent materials in transmitted light.

Programming of the reference colors using the teach-in method; either manually using a button on the sensor itself or directly via the PLC.

Available as a single-channel and three-channel model. Maximum switching frequency of the single-channel sensor: 1 kHz.

Solid die-cast housing with M 12 connector socket which can be rotated downwards or backwards through 90°.

Spurious pulse suppression especially for industrial environments and, of course, no maintenance is required.

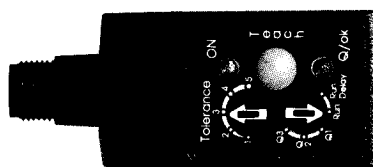

The controls of the CS 3 make programming extremely simple.

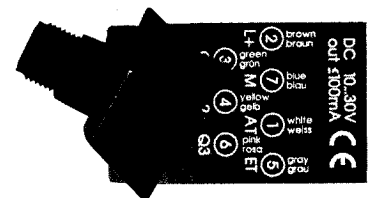

Connector socket can be rotated downwards and backwards

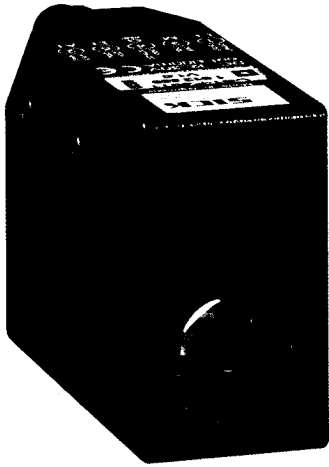

Scanning Range

12.5 and 60 mm



Range

50 to 1000 mm



Features:

- activ three way process
- color detection in reflected and transmitted light
- Programming using the teach-in method (manually or via the input line)
- Individual color selectivity setting
- 2 operating modes: permanent or synchronised (blanked)
- Pilot light
- Switching frequency 1 kHz
- Die-cast housing
- Hinged connector socket (can be rotated through 90°)
- CE

CS I

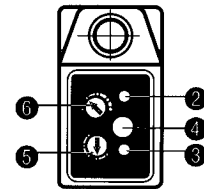
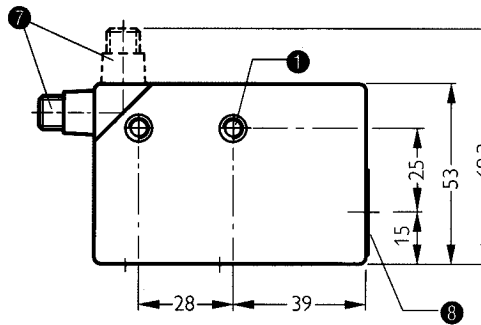
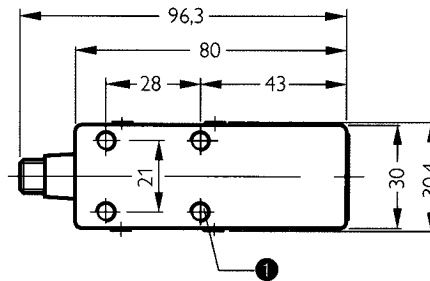

- ① Mounting holes M 5 – 5.5 deep
- ② Operating indicator (green)
- ③ Function indicator: switching output/teach (yellow)
- ④ Teach button
- ⑤ Program selector switch
- ⑥ color tolerance selector switch
- ⑦ Connector M 12 x 1; 5-pole (can be rotated through 90°)
- ⑧ Lens system (aperture)

Notes on Setting

In order to simplify setting and operation of the device, the reference color is programmed using the teach-in method.

The color selectivity can be set individually and is defined using the rotary switch. The reference colors can then be stored by simply pressing a button.

The programming procedure can also be carried out automatically via the External Teach (ET) input line. Each pulse causes the sensor to switch to programming mode and determine the color of the scanned object. The system then immediately returns to sensing mode.

Connection Diagram

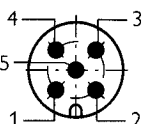
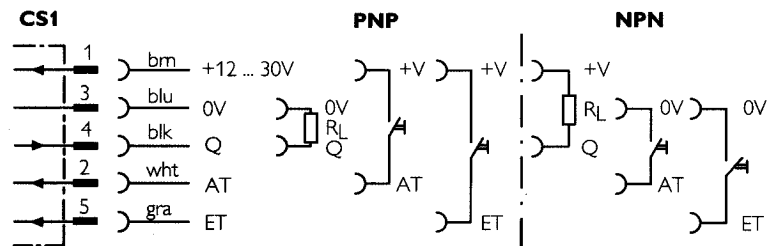

brn	wht	blu	blk	gra
brown	white	blue	black	gray

Color Sensor CS I

CS I	-P I III I	-N I III I	-P 36 I I	-N 36 I I
Part No.	1 012 858	1 012 862	1 012 859	1 012 863
Scanning distance SD¹⁾	12.5 mm		60 mm	
Scanning range tolerance	± 2 mm		± 9 mm	
Light spot dimensions	2 x 4 mm at distance of 12.5 mm		∅ 13 mm at distance of 60 mm	
Light spot position	Longitudinal			
Scanning range SR²⁾				
With reflector PL 80 A	100 to 250 mm (object-specific)		250 to 1000 mm (object-specific)	
With reflector PL 30 A	50 to 150 mm (object-specific)		200 to 750 mm (object-specific)	
Supply voltage V_S	12 to 30 VDC ³⁾			
Power consumption	≤ 80 mA ⁴⁾			
Residual ripple	< 5 V _{pp} ⁵⁾			
Service life of light source	Average service life 100,000 hrs at 25°C ambient temperature			
No. of colors which can be stored	1 color programmable			
Programming of reference color	Teach-in method (either with Teach-in button or External Teach ET input)			
Color selectivity/tolerance	Variable (Rotary selector switch, 5-step)			
Operating mode	Either permanently or synchronised (blanked)			
Immunity to external light sources	Up to 20 kLx with indirect constant light radiation			
Switching output	Q (Color detected/not detected)			
Switching method	PNP	NPN	PNP	NPN
Output voltage HIGH	V _S - (≤ 2 V)	V _S	V _S - (≤ 2 V)	V _S
Output voltage LOW	0 V	≤ 2 V	0 V	≤ 2 V
Output current max.	100 mA			
Switching frequency	1 kHz			
Response time	≤ 700 μs			
Timer (drop-out delay)	Variable: 0 ms (run), 20 ms drop-out delay (run delay)			
External Teach ET input	Programming of reference color via input line ET			
Type	PNP		NPN	
Teach-in (programming)	> 12 V to < V _{S max.}		0 V to V _S - (≥ 12 V)	
Run	< 2 V or open-circuited		V _S - (≤ 2 V) or open-circuited	
Teach pulse duration	≥ 0,5 ms			
Blanking input AT	PNP		NPN	
Blanked (triggered)	> 12 V to < V _{S max.}		0 V to V _S - (≥ 12 V)	
Asynchronous	< 2 V or open-circuited		V _S - (≤ 2 V) or open-circuited	
Response time	< 0,2 ms			
Degree of protection	IP 67			
VDE protection class	Ⓜ ⁶⁾			
Protective circuits ⁷⁾	A, B, C			
Ambient temperature T _A	- 10 to + 55 °C			
Storage temperature T _S	- 25 to + 70 °C			
Shock/vibration	IEC 68			
Weight	Approx. 400 g			

- 1) From edge of housing
 2) Dependent on the spectral transmission ratio/absorption of the object
 3) Limit values, reverse polarity protected

- 4) Without load, at 24 V
 5) Must not exceed or fall below V_S tolerances
 6) Totally insulated, class 2 to VDE 0110/0160 (Rated voltage 50 V)

- 7) A = V_S terminals, polarity-reversal-proof
 B = Switching output Q standard switch on/off, short-circuit and overload protection
 C = Spurious pulse suppression

Accessories

Socket M 12 x 1; 5-pole, straight, 2 m connecting cable with integral plug, Part No. 6 008 899, 5 m connecting cable with integral plug, Part No. 6 008 868
 Socket M 12 x 1; 5-pole, angled, 2 m connecting cable with integral plug, Part No. 6 008 900, 5 m connecting cable with integral plug, Part No. 6 008 869
 Reflector PL 80 A, Part No. 1 003 865, Reflector PL 30 A, Part No. 1 002 314 (see page 281)

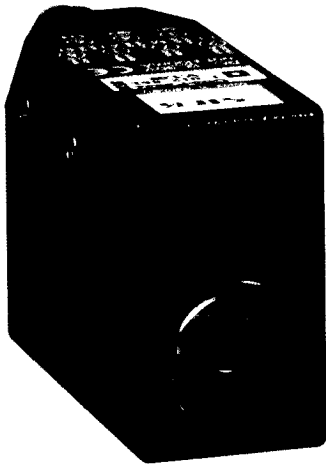

Scanning Range

12.5 and 60 mm



Range

50 to 1000 mm



Features:

- activ three way process
- Color detection in reflected and transmitted light
- Programming using the teach-in method (manually or channel 1 via the input line)
- 3 reference colors can be stored
- Individual color selectivity setting for each channel
- Standardisation method with level optimisation
- 2 operating modes: permanent or synchronised (blanked)
- Pilot light
- Die-cast housing
- Hinged connector socket (can be rotated through 90°)
- CE

CS 3

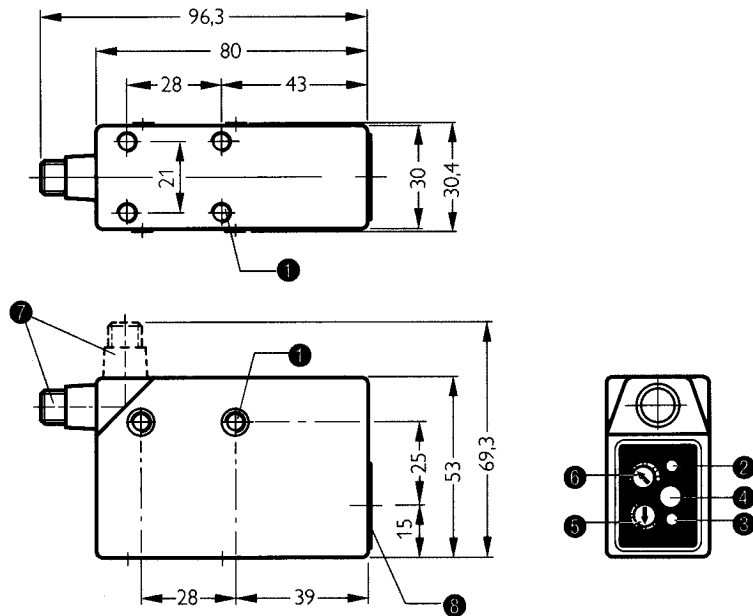

- ① Mounting holes M 5 - 5.5 deep
- ② Operating indicator (green)
- ③ Function indicator: switching output/teach (yellow)
- ④ Teach button
- ⑤ Program selector switch
- ⑥ Color tolerance selector switch
- ⑦ Connector M 12 x 1; 8-pole (hinged)
- ⑧ Lens system (aperture)

Notes on Setting

In order to simplify setting and operation of the device, the reference color is programmed using the teach-in method.

The color selectivity can be set for each channel individually. The channel and color tolerance are set by changing the position of the rotary switch. The reference colors can then be stored by simply pressing a button.

Channel 1 can also be programmed automatically via the External Teach (ET) input line. Each pulse causes the sensor to switch to programming mode and determine the color of the scanned object. The system then returns to sensing mode.

Connection Diagram

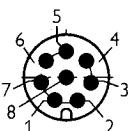
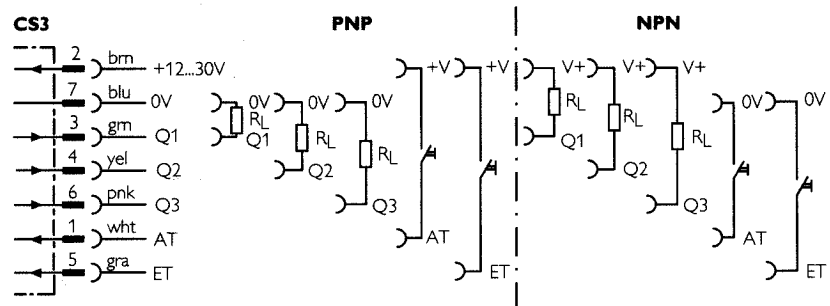

wht	brn	grn	yel	gra	pnk	blu
white	brown	green	yellow	gray	pink	blue

