

HP100 Series

The convenience of industry standards, plus reliability.



- Effective light axis alignment
- 50% power savings
- Prevention of accidental switch operation
- Guaranteed wide operating temperature range
- Longest scanning distance in the industry
- No damage from any wiring error
- Reduced operating error due to noise
- Error due to ambient light greatly reduced
- Significant reduction in error due to sensor mutual interference



CLICK

EXPLANATION OF MAJOR FUNCTIONS AND FEATURES

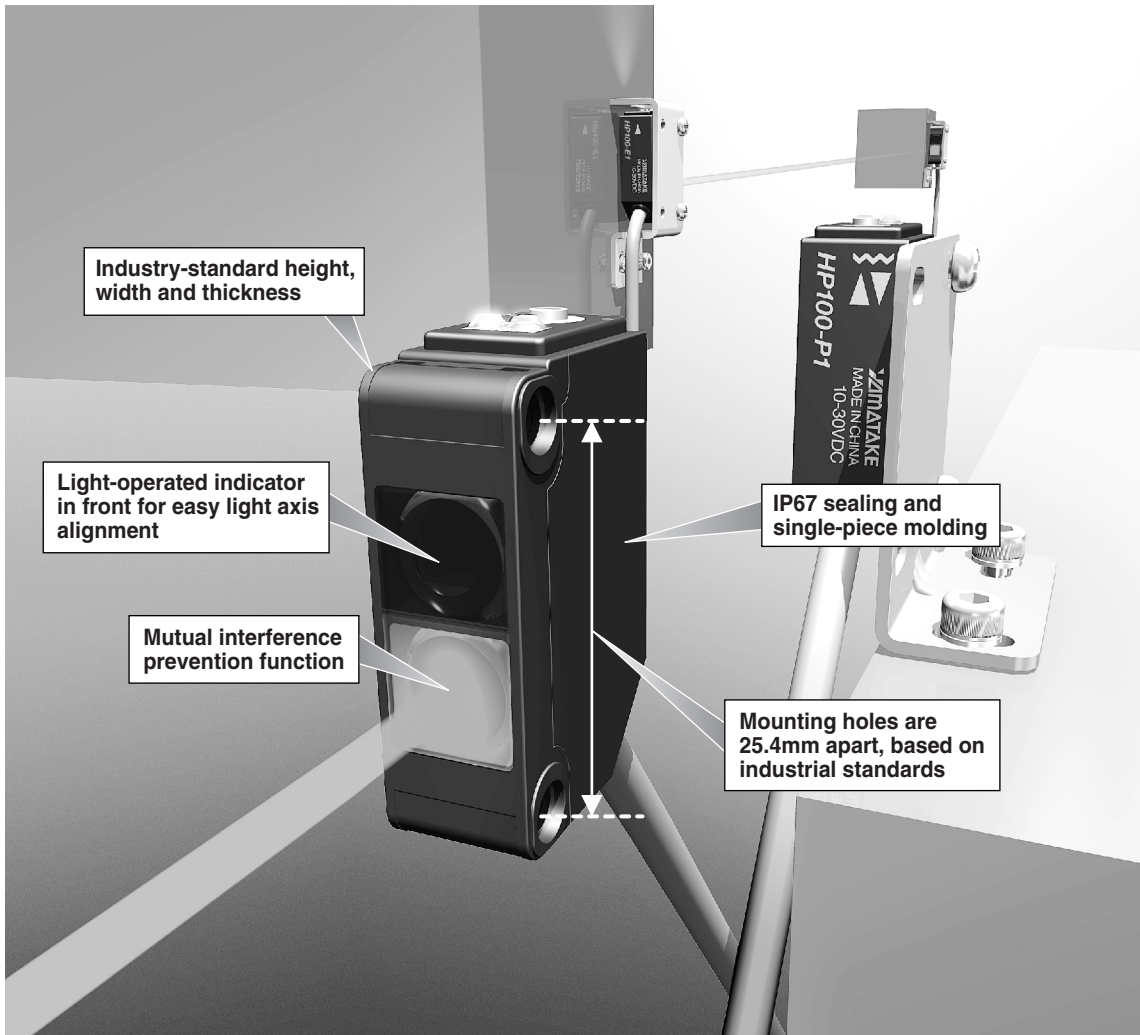

- Longest scanning distance in the industry!

Environment

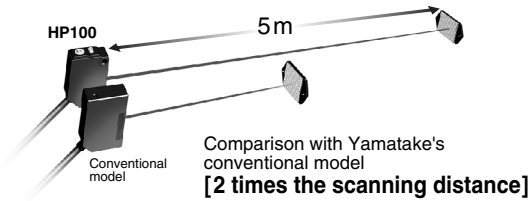

- Effective light axis alignment!

Putting a light-operated indicator in front ensures reliable confirmation of indicator operation by only one person.

Installation

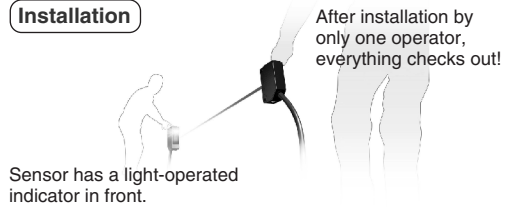

- Large reduction of operation error caused by ambient light!

Interference



- Reduction of operation error caused by noise!

Interference

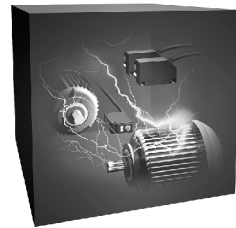

- Significant reduction in operation errors due to mutual interference between sensors!

Installation



- 50% power savings compared with Yamatake's conventional model!

Installation

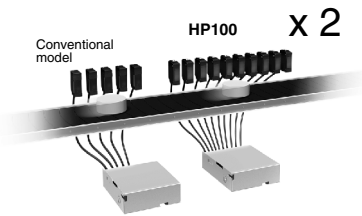

- No damage from any wiring error!

Installation

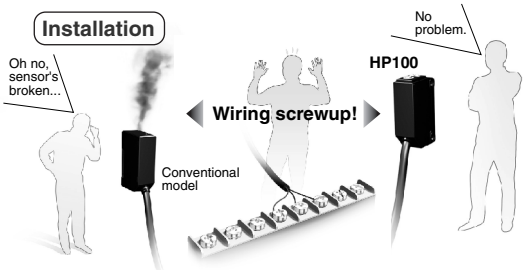

- Prevention of accidental switch operation!

Adjustment

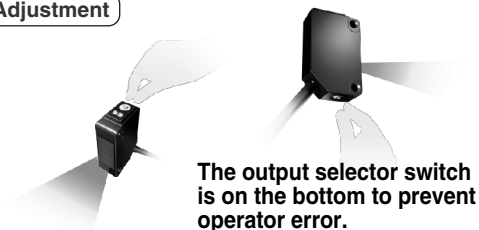

- Guaranteed wide operating temperature range!

Environment



CATALOG LISTINGS

Pre-leaded type (2m)













Detection method	Scanning distance	L-ON / D-ON selection	Sensitivity adjustment	Power supply	Output mode	Catalog listing
Thru-scan	15m	●	●	10 to 30Vdc	NPN open collector	HP100-T1
		●	●		PNP open collector	HP100-T2
Polarized retroreflective (when used with FE-RR8 or FE-RR17)	5m	●	●		NPN open collector	HP100-P1
		●	●		PNP open collector	HP100-P2
Diffuse-scan	1m	●	●		NPN open collector	HP100-A1
		●	●		PNP open collector	HP100-A2

Notes: 1. ● denotes availability. 2. An FET is used for output.

Pre-leaded type (50cm, 5m) and pre-leaded connector type (30cm, 50cm, 1m)

Type	Length	HP100-T □ -model	HP100-P/A □ -model
Pre-leaded connector	50cm	HP100-T □ -LP5	HP100-P/A □ -LP5
	5m	HP100-T □ -L05	HP100-P/A □ -L05
Pre-leaded connector (DIN M12 connector is used)	30cm	HP100-T □ -CN03	HP100-P/A □ -CN03
	50cm	HP100-T □ -CN05	HP100-P/A □ -CN05
	1m	HP100-T □ -CN1	HP100-P/A □ -CN1

Accessories

Name	Shape	Description	Catalog listing	Applicable model
Reflector for polarized retroreflective model		Reflector size 47 x 47mm	FE-RR8 Scanning distance 5m	HP100-P
		Reflector size 47 x 47mm	FE-RR17 Scanning distance 5m	HP100-P
		Reflector size 30.8 x 30.8mm	FE-RR15 Scanning distance 3.5m	HP100-P
		Reflector size 30.8 x 30.8mm	FE-RR18 Scanning distance 3.5m	HP100-P
		Reflector size 8.6mm x 29.5mm	FE-RR20 Scanning distance 2m	HP100-P
Standard bracket		Bottom-mounting L-bracket (material: SUS)	HP100-B01	All models
		Rear-mounting L-bracket (material: SUS)	HP100-B04	All models
Wraparound mounting bracket		Wraparound vertical mounting bracket (material: SUS)	HP100-B02	All models
		Wraparound horizontal mounting bracket (material: SUS)	HP100-B03	All models
Slit bracket for thru-scan model		Vertical slit bracket (0.5mm / 1mm / 1.5mm / 2mm)	HP100-SV05 / SV10 / SV15 / SV20	HP100-T
		Horizontal slit bracket (0.5mm / 1mm / 1.5mm / 2mm)	HP100-SH05 / SH10 / SH15 / SH20	HP100-T
Mutual interference protection filter for thru-scan model		Mutual interference can be prevented by changing the plane of polarization of 2 sets of adjacent emitter and receiver	HP100-U01	HP100-T

SPECIFICATIONS

Catalog listing	HP100-P1	HP100-P2	HP100-T1	HP100-T2	HP100-A1	HP100-A2
Detection system	Polarized retroreflective		Thru-scan		Diffuse-scan	
Power supply	10 to 30Vdc (ripple 10% max.)					
Current consumption	13mA max.		HP100-E1: 16mA max. HP100-R□: 11mA max.		16mA max.	
Scanning distance	5m (when used with reflector FE-RR8 or FE-RR17)		15m		1m	
Target object	Opaque object 80mm dia. min. (when used with reflector FE-RR8 or FE-RR17)		Opaque object 9mm dia. min.		—	
Standard target object	—		—		300 x 300mm white paper (Kodak 90% reflective paper)	
Scanning angle	Body: 1 to 10° Reflector: 30° min.		2 to 20°		—	
Differential travel	—		—		20% max. (at rated scanning distance)	
Operation mode	Light-ON / Dark-ON selectable by switch					
Output mode (Note 1)	HP100-□1: NPN open collector HP100-□2: PNP open collector					
Control output	Switching current: 100mA (resistive load). Output dielectric strength: 30V. Drop voltage: 3V max. (at switching current 100mA), with short-circuit protection function					
Response time	500μs max. for both operation and recovery					
Emitter	Red LED		Red LED		Infrared LED	
Indicator	Indicators other than thru-scan emitter: orange lit at output ON, and green lit at stable light-ON and light-OFF. Thru-scan emitter: orange light on power supply indicator. Thru-scan receiver: red light on front light-operated indicator.					
Ambient light immunity	Incandescent lamp: 10,000 lux max. Sunlight: 40,000 lux max.					
Operating temperature	-30 to +60°C (no condensation allowed)					
Operating humidity	35 to 85% RH (no condensation allowed)					
Storage temperature	-40 to +70°C (no condensation allowed)					
Insulation resistance	20MΩ min. (at 500Vdc)					
Dielectric strength	1,000Vac 50/60Hz for one minute between electrically live metal and case					
Vibration resistance	10 to 55Hz, 1.5mm peak-to-peak amplitude, 2 hours each in X, Y, and Z directions					
Shock resistance	500m/s² 10 times each in X, Y and Z directions					
Sealing	IP67 (IEC standard)					
Wiring method	HP100-□□-LP5: pre-leaded (0.5m), HP100-□□□: pre-leaded (2m), HP100-□-L05: pre-leaded (5m), HP100-□□-CN03: pre-leaded connector (0.3m), HP100-□□-CN05: pre-leaded connector (0.5m), HP100-□□-CN1: pre-leaded connector (1m)					
Weight	Approx. 55g (body with 2m cable only)					
Protection circuit	Power ON malfunction prevention circuit (approx. 8ms), wiring error protection					

Note 1. An FET is used for output

CHARACTERISTICS DIAGRAMS (typical examples)

Thru-scan model (HP100-T)

Parallel motion characteristics

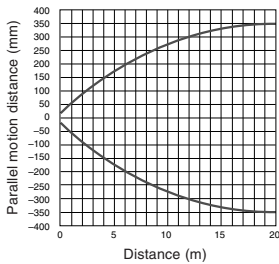

Excess gain (Light receiving level margin)

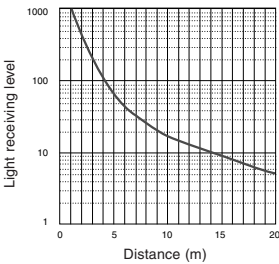

Polarized retroreflective model (HP100-P)

Parallel motion characteristics

Combined with FE-RR8 or with FE-RR15

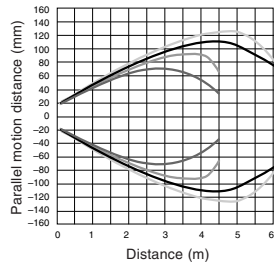

Excess gain (Light receiving level margin)

Combined with FE-RR8 or with FE-RR15

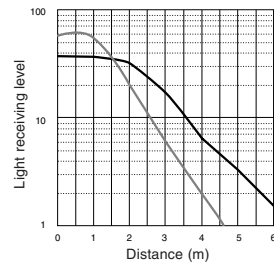

Diffuse-scan model (HP100-A)

Detection area characteristics

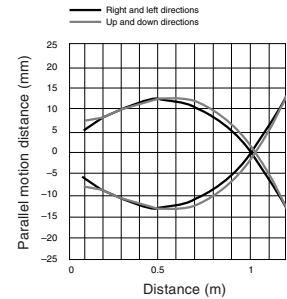

Excess gain (Light receiving level margin)

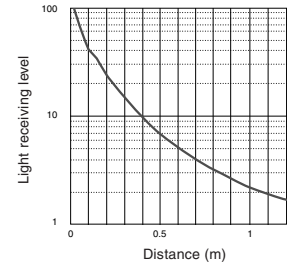

EXTERNAL DIMENSIONS

(unit: mm)

HP100-P / HP100-A

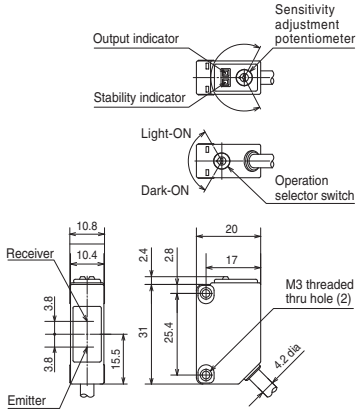

HP100-T (Emitter: HP100-E1)

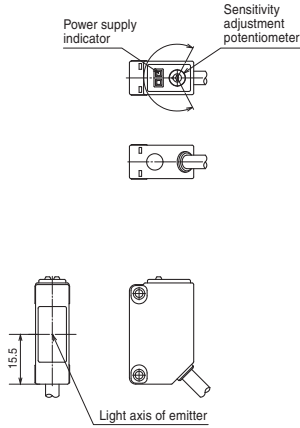

HP100-T (Receiver: HP100-R)

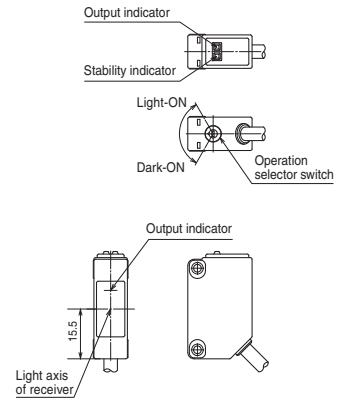

Bracket (sold separately)

Bottom-mounting L-bracket (HP100-B01)

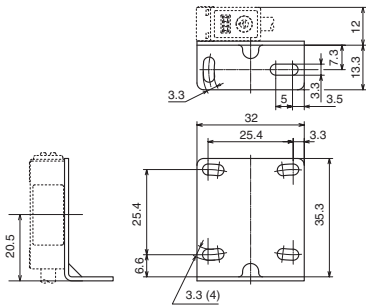

Rear-mounting L-bracket (HP100-B04)

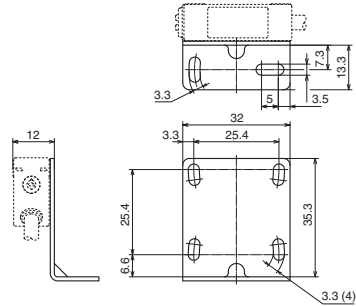

Wraparound vertical mounting bracket (HP100-B02)

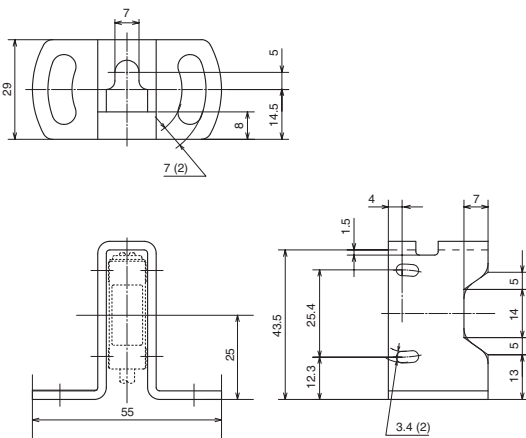

Wraparound horizontal mounting bracket (HP100-B03)

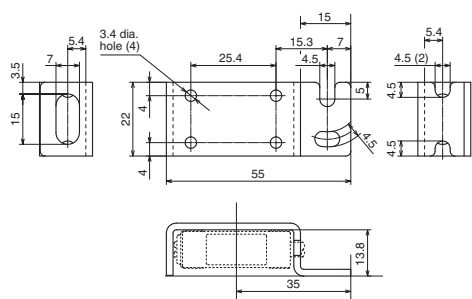

Reflector (sold separately)

FE-RR8

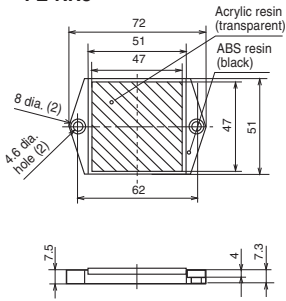

FE-RR15

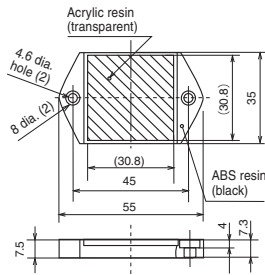

FE-RR17

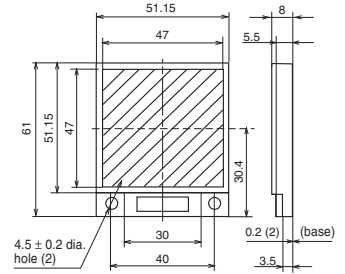

FE-RR18

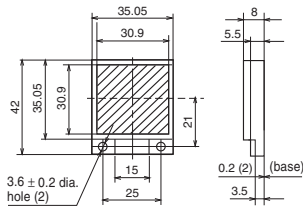

FE-RR20

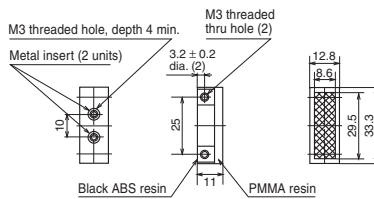

Slit and filter

Vertical slit

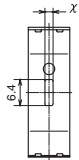

- HP100-SV05
- SV10
- SV15
- SV20

Horizontal slit

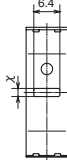

- HP100-SH05
- SH10
- SH15
- SH20

Filter

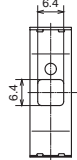

HP100-U01

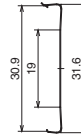

OUTPUT CIRCUIT DIAGRAM

Thru-scan emitter

(NPN output type)
Polarized retroreflector model
Thru-scan receiver
Diffuse-scan model

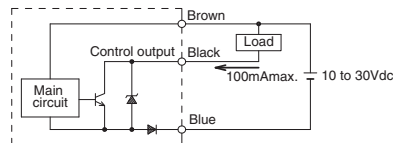
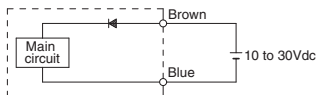

(PNP output type)
Polarized retroreflector model
Thru-scan receiver
Diffuse-scan model

