



ADVANCED M MODELS

⚠ WARNING

IMPROPER INSTALLATION

Consult with US and/or European safety agencies and their requirements when designing a machine control link, interface and all control elements that affect safety.

- Strictly adhere to all installation instructions.

Failure to comply with these instructions could result in death or serious injury.



REQUIREMENT YOU MUST MEET WHEN INSTALLING AND USING THE HONEYWELL SAFETY LIGHT CURTAINS

DANGER

FAILURE TO COMPLY WITH THESE INSTRUCTIONS WILL RESULT IN DEATH OR SERIOUS INJURY.

Full revolution clutched machinery cannot be stopped in mid-stroke

DO NOT use the Honeywell safety light curtains on full revolution clutched machinery, which cannot be stopped in mid-stroke.

Use the Honeywell safety light curtains on machinery that can be stopped at any point in the stroke or cycle.

WARNING

FAILURE TO COMPLY WITH THESE INSTRUCTIONS COULD RESULT IN DEATH OR SERIOUS INJURY.

Improper installation of the Honeywell safety light curtain

- Install the Honeywell safety light curtains in accordance with this installation manual and applicable local safety regulations (OSHA, ANSI, European standards).
- Allow entry into protected area by interruption of sensing field of the safety light curtain or activation of another safeguarding device only.

Improper system performance

- Comply with local safety requirements when designing machine control link, interface and all control elements that affect safety.
- Install two independent safety relay contacts into machine control stop circuit controlled by the Honeywell safety light curtain.
- Ensure two independent stop circuit relays have mechanically linked contacts to reliably detect a welded contact.
- Using one of the recommended Honeywell safety relay modules will provide safe relay contacts to the machine control stop circuit.

Improper machine reaction

- Ensure the machine control is capable of stopping the machine at any point in the cycle.
- Ensure that a loss of power does NOT impair stopping action of the machine.
- Cancellation of the safety light curtain stop signal must not cause the restart of the moving parts. The function to restart can only be initiated by means of a control designed for this purpose.

Electric shock hazard

- Turn off and disconnect power from the safety light curtain and from the machinery it is connected to before making any wiring connections. This includes disconnecting power to the machine control and motor.
- Ensure that installation is performed by qualified personnel.

Improper installation

Strictly adhere to all electrical connection instructions.

Improper maintenance

Strictly adhere to all maintenance and troubleshooting instructions.

Tests and controls

Always perform tests and controls listed in this installation manual after any installation modification.

TABLE OF CONTENT

1. Use of this document	p. 3
1.1. Depth of information	p. 3
1.2. Target group	p. 3
1.3. Important highlighted information.....	p. 3
1.4. Abbreviations.....	p. 3
1.5. Regulation and norms	p. 3
1.5.1. Approvals.....	p. 3
1.5.2. European directives compliance	p. 3
1.5.3. European standards compliance.....	p. 4
1.5.4. United states regulations compliance.....	p. 4
1.5.5. Additional protection	p. 4
1.6. Scope of this installation manual and part numbers	p. 5
2. Description and operation	p. 6
2.1. Synchronisation	p. 6
2.2. Resolution	p. 6
2.3. Protection height.....	p. 6
2.4. Scanning range	p. 6
3. Mounting considerations	p. 7
3.1. Optical alignment and mutual interference	p. 7
3.2. How to calculate safety distance.....	p. 7
3.2.1. Safety distances per ISO 13855 (EN999) standard.....	p. 7
3.2.2. Safety distances per USA's ANSI requirements (ANSI/RIA R15.06)	p. 8
3.3. How to calculate minimum distance considering reflective surfaces.....	p. 10
3.4. Vertical mounting	p. 10
3.5. Linear assembly	p. 11
3.6. Side by side assembly.....	p. 12
3.7. Diagonal or right-angle mounting.....	p. 12
3.8. Perimeter protection	p. 13
4. Device power	p. 13
5. Device machine stop contacts	p. 13
6. Connection to the machine control circuitry	p. 14
7. Auto or manual restart	p. 14
8. External device monitoring	p. 15
9. Muting function	p. 16
9.1. Overview.....	p. 16
9.2. Muting inputs.....	p. 16
10. Test and controls	p. 18
10.1. Operational test	p. 18
10.2. Commissioning check-list.....	p. 18
11. Cleaning	p. 18
ANNEX	
A. Specifications table.....	p. 20
B. Dimensions - materials.....	p. 21
C. Weight, protection heights, response times	p. 22
D. Mechanical mounting	p. 23
E. Wiring diagrams	p. 24
F. Indicators and troubleshooting.....	p. 25
G. Application notes.....	p. 26
H. CE Declaration Of Conformity.....	p. 33
Point of sales	p. 35

1. USE OF THIS DOCUMENT

1.1 Depth of information



Thank you for purchasing this Honeywell safety product. This manual contains description, operation, installation, electrical connections, maintenance and troubleshooting information related to the purchased product. These installation instructions do not provide instructions for operating the machine on which the Honeywell safety product is installed. Information about the machine operation can be found in the machine manufacturer's operating instructions.

1.2 Target group

Installation and use of this product must be performed by a qualified person thoroughly familiar with all instructions contained within this manual and all applicable safety regulations including those described below.

1.3 Important highlighted information

Important danger, warning, caution and notices are highlighted throughout the manual as follows:

 DANGER	 WARNING	CAUTION	NOTICE
<i>A DANGER symbol indicates an imminently hazardous situation which, if not avoided, will result in death or serious injury.</i>	<i>A WARNING symbol indicates a potentially hazardous situation which, if not avoided, could result in death or serious injury.</i>	<i>A CAUTION symbol indicates a potentially hazardous situation which, if not avoided, may result in property damage.</i>	<i>A NOTICE symbol indicates important information that must be remembered and aids in job performance.</i>

1.4 Abbreviations

OSSD	Output Signal Switching Devices (light curtain safety outputs)
AUTO	Automatic restart
RES	Manual restart
Selec RES	Selectable Automatic or Manual Restart
EDM	External Device Monitoring
FSD	Final Switching Device

1.5 Regulation and norms

1.5.1 Approvals

Approvals	Description
CE	Packaging, documentation and the products carry the CE mark. The EC declaration of conformity is at the back of this manual.
cCSAus	The Canadian Standard Association (CSA) has been accredited as a Nationally Recognised Testing Laboratory (NRTL) by the US Occupational Safety and Health Administration (OSHA). The CSA is able to carry out tests according to the Canadian and UL standards and deliver a single certificate which is valid for both Canada and the United States.

1.5.2 European directives compliance

Directives	Number
Machine Directive	98/37/EC
Low Voltage Directive	2006/95/EC
Electromagnetic Compatibility Directive	2004/108/EC

The EC type examination certificate granted by the French "Institut National de la Recherche et de la Sécurité (INRS)" guarantees the conformity of the product with respect to the essential requirements of the Machinery Directive 98/37/EC. To complete the EC type examination, further tests have been carried out by external laboratories to guarantee the conformity of the product with respect to the Low Voltage 2006/95/EC and the Electromagnetic Compatibility 2004/108/EC.

An EC declaration of conformity will be found at the back of this manual.

1.5.3 European standards compliance

This product complies with the following European standards:

Standard	Title
EN 292	Safety of Machinery - Basic concepts, general principles for design
EN 60204-1	Safety of Machinery - Electrical equipment of machines
EN 954-1	Safety of Machinery - Safety related parts of control systems
IEC/EN 61496-1	Safety of Machinery - Electro-sensitive protective equipment - part 1: General requirements and tests
IEC/EN 61496-2	Safety of Machinery - Electro-sensitive protective equipment - part 2: Active optoelectronic Protective Devices
EN 61508	Functional safety of Electrical/Electronic/programmable Electronic Safety. Related Systems

1.5.4 United states regulations compliance

US Regulation	Title
OSHA 29 CFR 1910.212	General Requirements for (guarding of) All Machines
OSHA 29 CFR 1910.217	(Guarding of) Mechanical Power Presses

1.5.5 Additional protection

In some applications, it may be necessary to provide additional protection to maintain the protection level provided by the safety light curtain. Hard guards or additional safety devices, may be used to ensure the operator is either forced to move through the sensing field to enter the danger zone, or forced to stand on the sensing area inside the danger zone.

Hard guards should be installed permanently with the aid of a tool or welded. If hard guards need to be automatically positioned, their positioning must be checked. It must not be possible for operators to neutralise the detectors associated with these hard guards. Hard guards shall comply with the local regulations and standards.

1.6 Scope of this installation manual and part numbers

This installation manual covers the following FF-ST4 models:

PROTECTION HEIGHT

Coding	Height (mm)
02	200
03	300
04	400
05	500
06	600
07	700
08	800
09	900*
10	1000
11	1100*
12	1200
13	1300*
14	1400
15	1500*
16	1600*
18	1800*

(*): available for FF-ST4C models only

Examples:

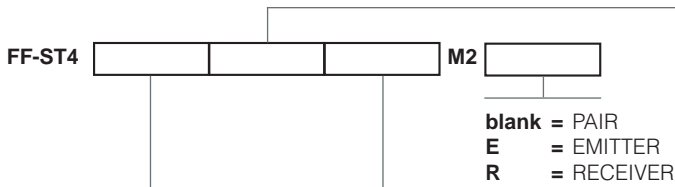
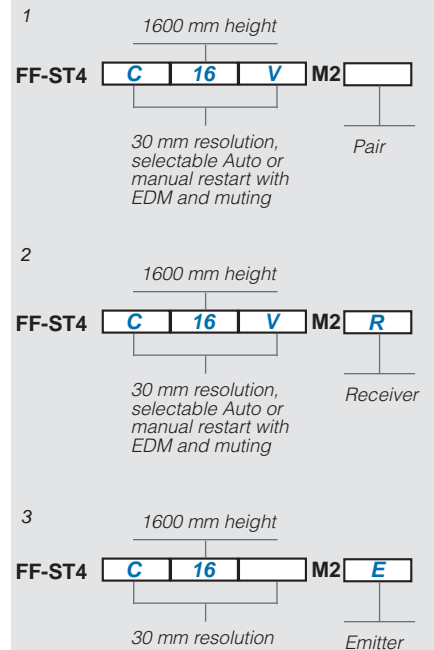

FUNCTION PACK

Emitter Receiver & Pair Coding	Receiver & Pair Coding	Resolution	Function Package	Protection Height
A	S	14	AUTO & MUTING	02 to 14
B	S	18	AUTO & MUTING	02 to 14
C	S	30	AUTO & MUTING	02 to 18
A	W	26 ⁽¹⁾	AUTO & MUTING	02 to 14
B	W	30 ⁽¹⁾	AUTO & MUTING	02 to 14
C	W	54 ⁽¹⁾	AUTO & MUTING	02 to 18
A	A1	38 ⁽¹⁾	AUTO & MUTING	02 to 14
B	A1	42 ⁽¹⁾	AUTO & MUTING	02 to 14
C	A1	80 ⁽¹⁾	AUTO & MUTING	02 to 18
A	T	14	RES/EDM & MUTING	02 to 14
B	T	18	RES/EDM & MUTING	02 to 14
C	T	30	RES/EDM & MUTING	02 to 18
A	X	26 ⁽¹⁾	RES/EDM & MUTING	02 to 14
B	X	30 ⁽¹⁾	RES/EDM & MUTING	02 to 14
C	X	54 ⁽¹⁾	RES/EDM & MUTING	02 to 18
A	B1	38 ⁽¹⁾	RES/EDM & MUTING	02 to 14
B	B1	42 ⁽¹⁾	RES/EDM & MUTING	02 to 14
C	B1	80 ⁽¹⁾	RES/EDM & MUTING	02 to 18
A	U	14	AUTO/EDM & MUTING	02 to 14
B	U	18	AUTO/EDM & MUTING	02 to 14
C	U	30	AUTO/EDM & MUTING	02 to 18
A	Y	26 ⁽¹⁾	AUTO/EDM & MUTING	02 to 14
B	Y	30 ⁽¹⁾	AUTO/EDM & MUTING	02 to 14
C	Y	54 ⁽¹⁾	AUTO/EDM & MUTING	02 to 18
A	C1	38 ⁽¹⁾	AUTO/EDM & MUTING	02 to 14
B	C1	42 ⁽¹⁾	AUTO/EDM & MUTING	02 to 14
C	C1	80 ⁽¹⁾	AUTO/EDM & MUTING	02 to 18
A	V	14	Selec RES/EDM & MUTING	02 to 14
B	V	18	Selec RES/EDM & MUTING	02 to 14
C	V	30	Selec RES/EDM & MUTING	02 to 18
A	Z	26 ⁽¹⁾	Selec RES/EDM & MUTING	02 to 14
B	Z	30 ⁽¹⁾	Selec RES/EDM & MUTING	02 to 14
C	Z	54 ⁽¹⁾	Selec RES/EDM & MUTING	02 to 18
A	D1	38 ⁽¹⁾	Selec RES/EDM & MUTING	02 to 14
B	D1	42 ⁽¹⁾	Selec RES/EDM & MUTING	02 to 14
C	D1	80 ⁽¹⁾	Selec RES/EDM & MUTING	02 to 18

(1) see resolution definition in chapter "Description and operation"

FF-ST Operational Diagram

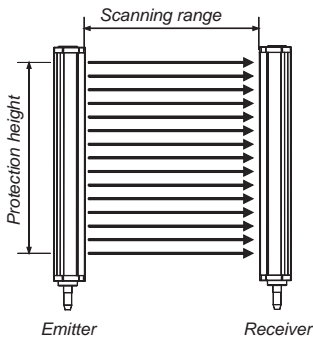

Light Curtain Resolution

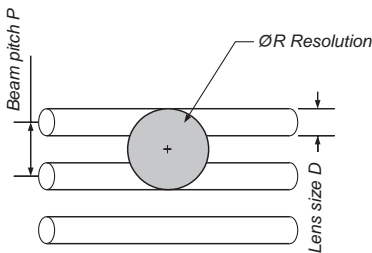

2. DESCRIPTION AND OPERATION

The FF-ST Series are through-scan light curtains. Emitters transmit modulated, infrared light that is detected by photo receivers in the receiver. The number of light beams depends on the protected height and resolution of the light curtain.

FF-ST Series light curtains generate a stop signal if the sensing field is interrupted. Further operation is prevented until the sensing field is cleared. The FF-ST Series light curtain monitors itself continuously for component failures, misalignments, and dirt accumulation. If misalignment or dirt accumulations become too great or a component fails, a stop signal is generated. Operation is prevented until the condition is corrected.

2.1. Synchronisation

The emitter and the receiver are optically synchronised. The synchronisation is an effective beam transmitted by the emitter towards the receiver. No electrical connection is necessary between the emitter and the receiver that simplifies installation and maintenance.

2.2. Resolution

FF-ST Series light curtain resolution (sometimes called minimum object sensitivity) is the minimum object size that will interrupt at least one light beam when it enters the sensing field. Anything entering the sensing field equal to or greater than this minimum size will be detected. Resolution is not affected by scanning distance or dust accumulation. Two factors determine the resolution of the light curtain: beam pitch and lens diameter. Lens diameter is the smallest width that will block a single light beam. The combination of the beam diameter and centre distance gives the FF-ST the resolutions indicated in chapter "Scope of this installation manual and part numbers".

NOTICE

For some of the FF-ST models, object sizes less than the following values will not be detected in the light curtain detection field:

Model numbers	Resolution	Undetected object size
FF-ST4A ... W, X, Y, Z	26 mm	Less than 10 mm
FF-ST4B ... W, X, Y, Z	30 mm	Less than 6 mm
FF-ST4C ... W, X, Y, Z	54 mm	Less than 18 mm
FF-ST4A ... A1, B1, C1, D1	38 mm	Less than 22 mm
FF-ST4B ... A1, B1, C1, D1	42 mm	Less than 18 mm
FF-ST4C ... A1, B1, C1, D1	80 mm	Less than 42 mm

2.3. Protection height

The protection height is the height on which the test rod will be detected. The uppermost and lowest beams are located as shown on the Dimension drawing in annex.

2.4. Scanning range

The scanning range is given by the minimum distance and maximum distance allowed between the emitter and the receiver (See Operating Characteristics in annex).

3. MOUNTING CONSIDERATIONS

3.1. Optical alignment and mutual interference

Proper optical alignment of the safety light curtains ensures optimum operation. The emitter and receiver units must be mounted in parallel, at the same height, and with no angular displacement. Correct alignment is achieved when the receiver red status led is off. See figure below for proper alignment.

Emitter and Receiver Optical Alignment

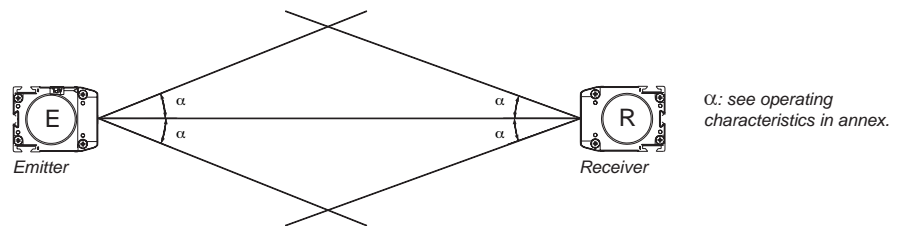

The safety light curtain is based upon an infrared transmission between an emitter unit and a receiver unit. It is a safety requirement of the IEC/EN 61496-2 standard that if a receiver R2 receives two signals transmitted by two different emitters E1 and E2, the receiver R2 must turn to the alarm state. This happens if the receiver R2 is within the beam aperture angle and within the scanning range of the second emitter E1. The receiver red status led flickers and the receiver OSSD red led is on when a cross-talk situation arises.

Mutual interferences between two light curtain sets

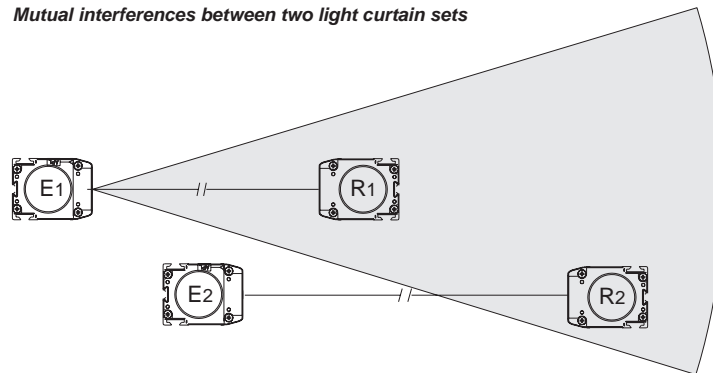

NOTICE

Mutual interference

Reception of two infrared emissions will maintain the light curtain in a lockout condition. To go back to normal operation, switch the power off and eliminate the interferences by reversing systems emitting orientation or by using opaque screens. Then, restore the power.

3.2 How to calculate safety distance

The safety distance is the minimum distance between the sensing field and the danger zone. This distance ensures that the danger zone cannot be reached until the machine motion has been stopped.

3.2.1 Safety distances per ISO 13855 (EN 999) standard

In Europe, calculate the safety distance using the following formula:

$$S = K(t_1 + t_2) + C$$

Where:

- **S** = is the safety distance (in mm) from the light curtain sensing field to the danger zone
- **K** = is the velocity (in mm/s) of movement into the danger zone
- **t₁** = is the response time (in s) of the light curtain.
- **t₂** = is the stopping time (in s) of the equipment guarded by the light curtain including interconnecting components such as all mechanical, electromechanical, and electronic parts such as relays, solenoids, and brakes.
- **C** = is an additional safety distance (in mm).

Direction of approach

Resolution $R \leq 40$ mm

Resolution $R > 40$ mm

Normal approach

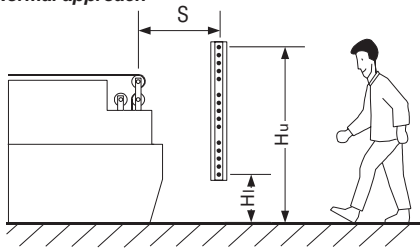

$S \geq 2000 (t_1+t_2) + 8 (R-14)$ with $S \geq 100$

$S \geq 1600 (t_1+t_2) + 850$
with $H_u \geq 900$ and $H_i \leq 300$

If $S \geq 500$, then use:
 $S \geq 1600 (t_1+t_2) + 8 (R-14)$ with $S \geq 500$

Parallel approach

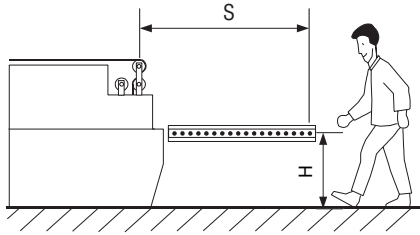

$S \geq 1600 (t_1+t_2) + (1200-0.4H)$ with $H \leq 875$ or
 $S \geq 1600 (t_1+t_2) + 850$ with $875 < H \leq 1000$

and $H \geq 15 (R-50)$

If $H > 300$, supplemental safeguarding may be required to detect crawling underneath.

Angled approach

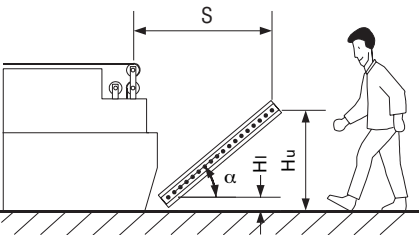

If the light curtain has been installed so that the angle of approach to the detection zone is within $\pm 5^\circ$ of their designed approach (either normal or parallel), then it needs not to be considered as an angled approach detection zone.

If $\alpha \geq 30^\circ$, then use the normal approach formula, with $H_u \geq 900$ mm and $H_i \leq 300$ mm

If $\alpha \leq 30^\circ$, then use the parallel approach formula, with $H_u \leq 1000$ mm and $H_i \geq 15 (R-50)$.

WARNING

Improper installation for point-of-operation

To prevent operating personnel from access to danger zone, install hard guard or right-angle mounting if distance between danger zone and closest light beam is greater than 70 mm / 2.8 in.

Failure to comply with these instructions could result in death or serious injury.

3.2.2. Safety distances per USA's ANSI requirements (ANSI/RIA R15.06)

In the USA, calculate the safety distance using the following formula:

$D_s \geq K (T_s+T_c+T_r) + D_{pf}$

Where:

- **Ds** = is the minimum safety distance from the light curtain sensing field to the danger zone (in inches)
- **K** = is the approach speed of movement to the danger zone (in inches per second)
- **Ts** = is the worst case stopping time of the machine (in seconds)
- **Tc** = is the worst case response time of the machine's control (in seconds)
- **Tr** = is the response time of the safety devices, light curtain plus its interface - meaning the response time including the mechanical relay outputs (in seconds)
- **Dpf** = Depth penetration factor (in inches).

Direction of approach

Resolution $R < 2.5$ in

Resolution $R \geq 2.5$ in

Normal approach

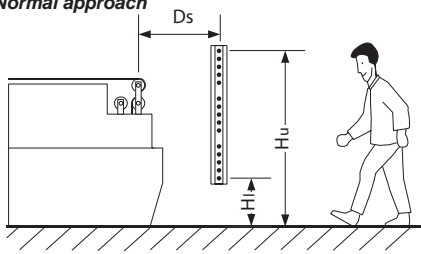

$Ds \geq 63 (Ts+Tc+Tr) + 3.4 (R-0.275)$
with $Ds \geq 7.5$, $Hi \leq 12$ and $Hu \geq 48$
(typical for reach thru)

or
 $Ds \geq 63 (Ts+Tc+Tr) + 48$
with $Hi \leq 12$ and $36 \leq Hu < 48$
(typical for reach over)

If $Hi > 12$, supplemental safeguarding may be required to detect crawling underneath.

$Ds \geq 63 (Ts+Tc+Tr) + 36$
with $Hi \leq 12$ and $Hu \geq 48$
(typical for reach thru)

or

$Ds \geq 63 (Ts+Tc+Tr) + 48$
with $Hi \leq 12$ and $36 \leq Hu < 48$
(typical for reach over)

If $Hi > 12$, supplemental safeguarding may be required to detect crawling underneath.

Parallel approach

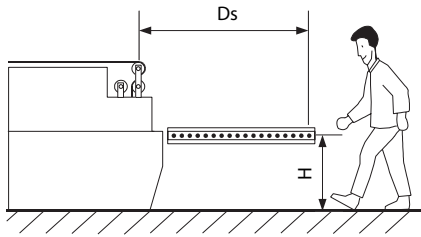

$Ds \geq 63 (Ts+Tc+Tr) + 48$ with $15 (R-2) \leq H \leq 39$

If H is greater than 12 inches, supplemental safeguarding may be required to detect crawling underneath.

Angled approach

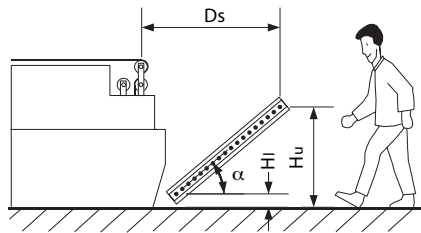

If $\alpha \geq 30^\circ$, then use the normal approach formula.

If $\alpha < 30^\circ$, then use the parallel approach formula.

3.3. How to calculate minimum distance considering reflective surfaces

WARNING

Reflective surfaces

- To prevent two optical paths to the receiver, install the light curtains so there are no reflective surfaces within the beam angles of the emitter and receiver.
- Calculate the reflective minimum distance using the following formula:

$D = 131 \text{ mm}$, for scanning distances between 0 and 3 m

$D = L \times \tan 2.5^\circ$, for scanning distances greater than 3 m

Where:

D = Minimum distance to reflective surface

L = Installed scanning range

Failure to comply with these instructions could result in death or serious injury.

Distance from Reflective Surfaces

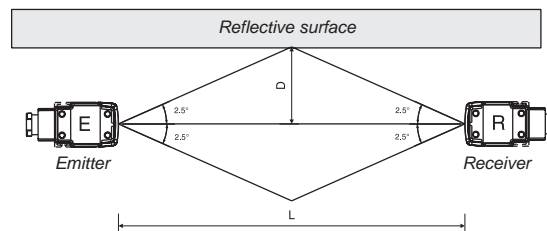

Distance from Reflective Surfaces

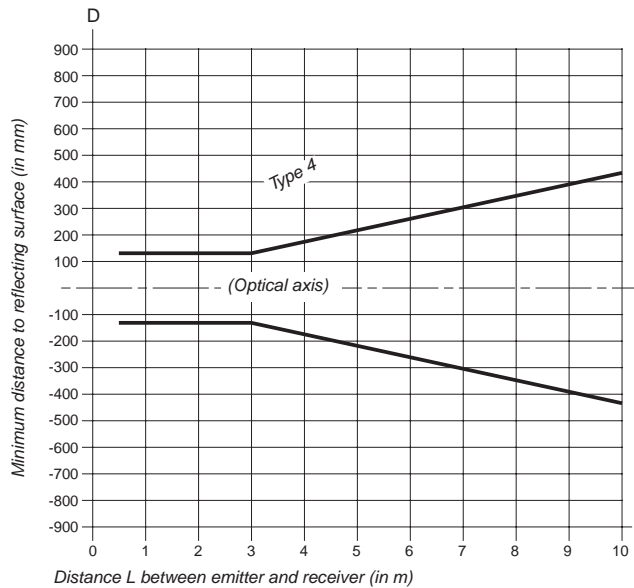

3.4. Vertical mounting

WARNING

Improper installation of the light curtain

- Mount the light curtains so that any entry into protected area must interrupt sensing field of the safety light curtain or activate other safeguarding devices.
- Install mechanical guards or additional light curtains to prevent operating personnel from reaching around, under, or over the sensing field.
- For point-of-operation guarding, the light curtain(s) and any mechanical guards must be installed to detect or prevent operating personnel from standing between the light curtain and the danger zone.

Failure to comply with these instructions could result in death or serious injury.

Point-of-operation Guarding

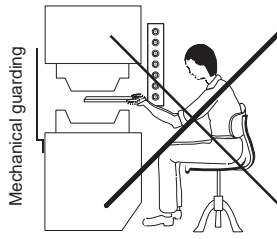

Operator enters danger zone under the light curtain

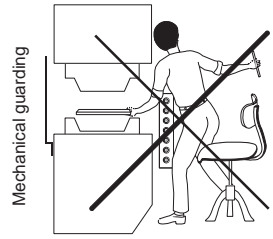
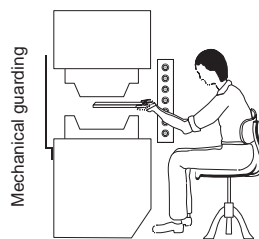

Operator enters danger zone above the light curtain

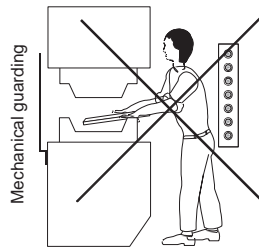

Operator is undetected between the light curtain and dangerous area

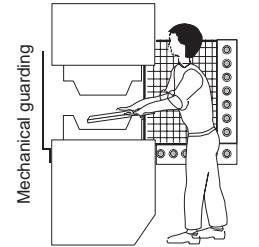

Right-angle mounting of two light curtains prevents undetected presence inside dangerous area

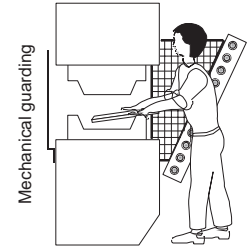

Light curtain mounted in an angled position prevents undetected presence inside the dangerous area

3.5. Linear assembly

NOTICE

Mutual interference

When two emitter/receiver units are mounted together to obtain a greater protected height, the emitter and receiver units must be mounted in a reverse transmitting position to prevent mutual interference. Reception of two infrared emissions will maintain the light curtain in a lockout condition. To go back to normal operation, switch off and on the light curtain power.

The units may be mounted with the overlapping housings to maintain the resolution throughout the protected height.

Linear Assembly

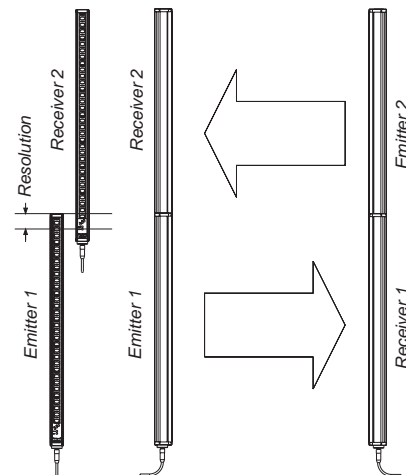

3.6. Side by side assembly

NOTICE

Mutual interference

When two or more light curtains are installed on adjacent machines, optical interference may occur if two units are within the field of view. Mutual interference between light curtains can be eliminated by reversing systems emitting orientation, or by using opaque screens. Reception of 2 infrared emissions will maintain the light curtain in a lockout condition. To go back to normal operation, switch off and on the light curtain power.

Side by side installation of two light curtains

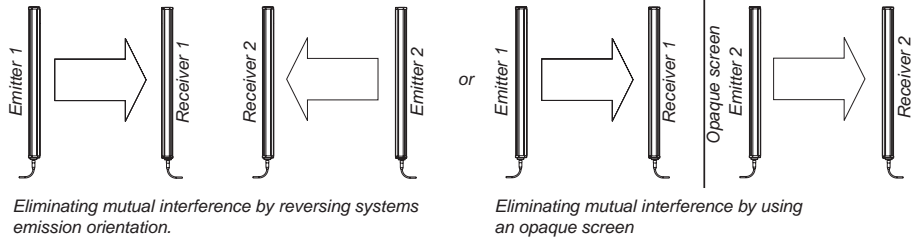

Side by side installation of more than two light curtains

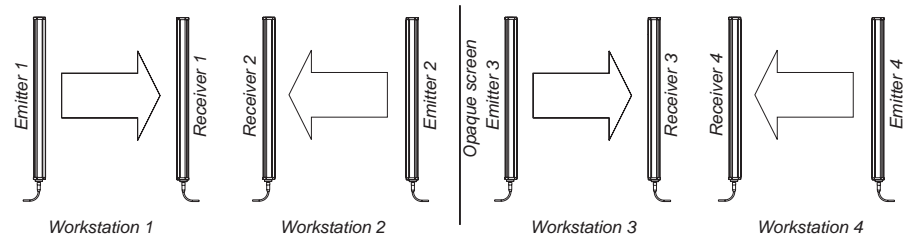

If the beams of two adjacent light curtains are reversed, no interference will occur between these two light curtains. If more than two light curtains are installed side by side, then some of them may interfere together. In the above example, Receivers 2 and 3 may respectively receive a signal from the emitters 4 and 1. An opaque screen can be used between emitter 2 and emitter 3 to solve this mutual interference problem.

3.7. Diagonal or right-angle mounting

For point-of-operation guarding, the safety light curtain(s) and any hard guarding must be installed so that no person can stand between the light curtain and the danger zone without being detected. Installation may require additional hard guarding, horizontal or diagonal mounting of the light curtain, or additional light curtains mounted at right angles to each other.

WARNING

Improper installation for point-of-operation

To prevent operating personnel from access to danger zone, install hard guard or right-angle mounting if distance between danger zone and closest light beam is greater than 70 mm / 2.8 in.

Failure to comply with these instructions could result in death or serious injury.

A right-angle mounting arrangement may be used if the altered resolution at the joint is acceptable to the local regulatory agency. The emitters and receivers units should be mounted with opposite orientations to prevent mutual interference.

Diagonal Mounting

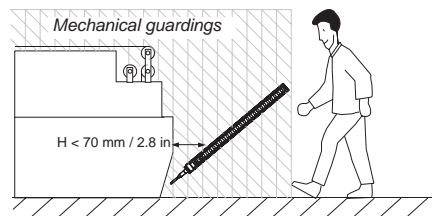

Right-Angle Mounting

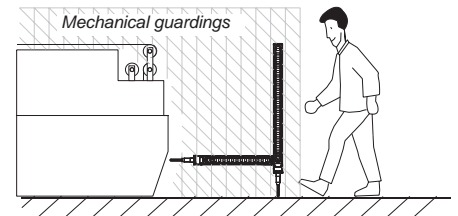

3.8. Perimeter protection

⚠ WARNING

Improper perimeter protection for resolution higher than 40 mm

- Design control circuit that requires a manual restart before further machine operation can occur.
- Locate manual restart to allow operator a clear view of danger zone.
- Operator must NOT be able to reach manual restart from within danger zone.
- Design control circuit to prevent Programmable Logic Controller from overriding manual restart.

Failure to comply with these instructions could result in death or serious injury.

Perimeter Guarding

(use the FF-ST light curtain with deflection mirrors)

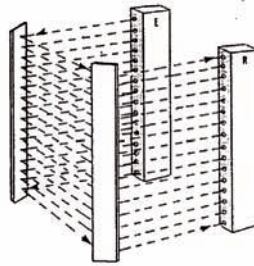

NOTICE

Perimeter length

The maximum achievable perimeter length depends upon the number of deflection mirrors used and depends upon the mirrors scanning range attenuation factor.

4. DEVICE POWER

FF-ST Series light curtains operate on 24 Vdc $\pm 20\%$ and are protected against reversed polarity.

CAUTION

External fuse protection

The light curtain supply inputs are protected from network disturbances by electronic components and internal fuses. However, use of external protection fuses (slow, 2.5 A) is recommended.

Power supply range

- Compliance with the specified supply voltage (24 Vdc $\pm 20\%$) is **STRICTLY** necessary.
- Network pikes are not filtered by non-regulated and non-stabilised power supplies and may damage the light curtain internal components. Subsequent return and repair is not covered by the standard warranty conditions.
- Use of a regulated and stabilised power supply is necessary. The Honeywell FF-SXZPWR050 power supply unit can be used to power 2 to 4 light curtains depending upon loads connected to their safety static (solid state) outputs.

Failure to comply with these instructions may result in product damage.

NOTICE

Power supply range

Running the unit with a lower supply voltage than specified may result in erratic outputs malfunctions.

Wiring information are given in annex.

NOTICE

5. DEVICE MACHINE STOP CONTACTS

Power cut-off protection

The FF-ST safety static (solid state) outputs withstand 10 ms power cut-off.

The use of the optional ac to dc power supply FF-SXZPWR050 improves the power cut of resistance up to 20 ms.

NOTICE**Connection of FF-ST static (solid state) outputs to the power supply**

- *By-passing the FF-ST static (solid state) outputs by connecting them to the power supply will be detected by the FF-ST safety light curtain.*
- *If the static (solid state) outputs are temporarily connected to +24 Vdc, the light curtain will remain locked-out and outputs will remain open. Normal operation is achieved by switching the power off and on once the failure condition has been removed.*
- *If the static (solid state) outputs are temporarily connected to 0 Vdc, the output will remain permanently open, even after the outputs are removed from this connection. Normal operation is achieved by switching the power off and on once the failure condition has been removed.*

Improper use of the FF-ST light curtain

The cross-monitoring of the FF-ST static (solid state) outputs is based upon a self-checking principle which ensures the detection of an output short-circuit and the detection of a short-circuit between the outputs (cross-fault detection). The compatible safety relay modules are primarily designed to be interfaced with Honeywell safety static (solid state) outputs. Compatibility with any other emergency stop relay module is not guaranteed.

Protection of machine stop contacts

- *It is recommended to connect 31 Vdc varistors in parallel with the FSD's relay coils.*
- *Use of RC circuits across the loads will prevent the light curtain from operating.*

⚠ WARNING**Improper protection installation**

- *Never install varistors across the static (solid state) safety output of the light curtain.*
- *Always install varistors across the coils of the external safety relays.*

Failure to comply with these instructions could result in death or serious injury.

6. CONNECTION TO THE MACHINE CONTROL CIRCUITRY

The switching capacity of the static (solid state) output (350 mA/24 Vdc) combined with the number of available outputs displayed by the equipment (2 Normally Open outputs) means that the equipment may be connected to two external relays with guided contacts K1 and K2 (usually called "Final Switching Devices" - FSDs). These FSDs must be regularly controlled.

⚠ WARNING**Improper external safety relays performance**

Use two independent stop circuit safety relays K1, K2 with mechanically linked contacts (such as Telemecanique CA3-KN31BD relay) and the FF-ST EDM input to reliably detect a welded contact.

Improper use of the FF-ST light curtain

The loads impedance allowed by the FF-ST safety static (solid state) outputs must be 70 Ω minimum and 5 kΩ maximum. The turn-on voltage must be greater than 5 V on resistive loads or greater than 7 V on inductive loads.

Failure to comply with these instructions could result in death or serious injury.

NOTICE**Light curtain restart time**

It takes 80 ms for the light curtain to restart after each beam release (150 ms in the manual mode).

Wiring information are given in annex.

7. AUTO OR MANUAL RESTART

Depending upon models, the FF-ST can be used in automatic or manual restart mode. In automatic mode, the outputs will switch back to ON after an interruption of the protection field, as soon as the field becomes clear again. In manual restart mode, the FF-ST will not switch back its outputs to ON until a manual restart push-button is pressed and released. The push-button must be a normally closed type button. The manual restart will not switch the OSSDs back to ON in case of light curtain lock out (internal failure, light interference, etc.), or when the protection field is interrupted, or in case of Final Switching Device failure.

Manual restart time diagram

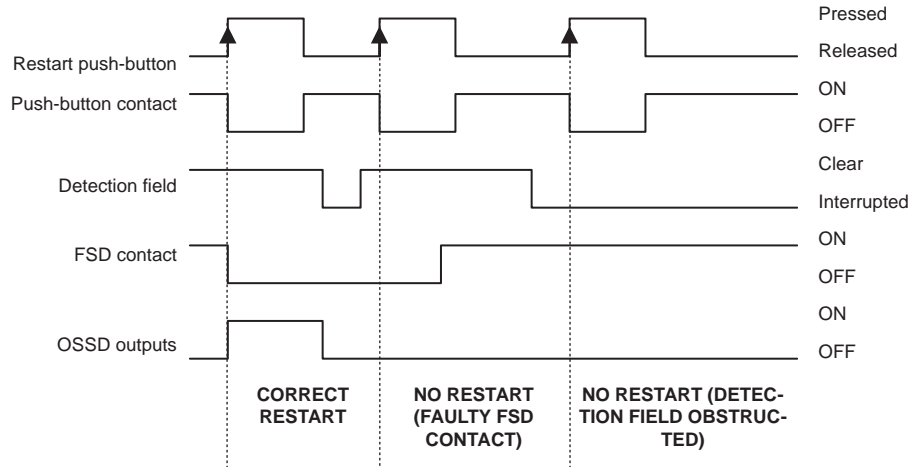

⚠ WARNING

Improper restart installation

- Locate manual restart to allow operator a clear view of hazard zone.
- Operator must NOT be able to reach manual restart from within hazard zone
- Design control circuit to prevent the Programmable Logic Controller from overriding manual restart.

Failure to comply with these instructions could result in death or serious injury.

The restart mode is either preset on delivery, or selectable through wiring.

To find out whether your product operates in the automatic or manual restart mode, refer to chapter "Scope of this installation manual and part numbers".

Wiring information are given in annex.

8. EXTERNAL DEVICE MONITORING (EDM)

Most of the FF-ST models are fitted with an EDM input which allows users to check the correct state of the final switching devices (relays, contactors, etc.). The EDM input checks if the external devices (relays or contactors) actually change state when the protective device is actuated. If no correct change of state is detected, the FF-ST will not switch the OSSDs back to ON.

After each intrusion into the protection field, the FF-ST will check that the EDM input loop is closed before switching the outputs back to ON. If the FF-ST operates in automatic restart mode, it will restart immediately if the EDM loop is closed. If the FF-ST operates in manual restart mode, it will restart when the restart push-button is pressed and if the EDM loop is closed. If the EDM loop remains open (meaning that the external device has a malfunction) the FF-ST will keep its outputs open and will not restart.

The EDM is achieved by feeding the Normally Closed contacts of the external devices into the EDM/restart input. If the correct voltage is not detected by the light curtain after an interruption of the protection field, this means that one of the contact elements is defective and the EDM prevents the light curtain restart.

To find out whether your product is fitted with the EDM input, refer to chapter "Scope of this installation manual and part numbers".

Wiring information are given in annex.

9. MUTING FUNCTION

9.1. Overview

The muting function enables the inhibition of the safety light curtain during certain stages of operation, the OSSD outputs remaining active. This function is particularly suitable when objects have to pass through the FF-ST protection field, under certain conditions.

For example, on a machine automatically fed by a conveyor, parts must be moved through the detection field of the safety light curtain towards the dangerous area without causing the immediate stoppage of the machine. Similarly, manual loading and unloading of a machine may be allowed while the machine tool goes back to its home position.

When the protective equipment is not muted, any intrusion of an object or a person inside the FF-ST detection field immediately stops the machine.

⚠ WARNING

Mechanical power press operating in reverse mode

- *The Honeywell muting function shall only be used during non-hazardous portion of the mechanical power press cycle, i.e. during die opening when the press is running forward (crankshaft is running clockwise).*
- *If it is foreseeable that the press may be run in reverse or the press crankshaft rotation direction changed, even accidentally, DO NOT install the Honeywell muting system on the press.*
- *The muting function provided by the Honeywell product DOES NOT recognize the crankshaft rotation direction (clockwise or counter clockwise). If muting is installed to operate during the upstroke when running forward (clockwise), then muting should not occur during the down stroke when running reverse (counter clockwise). Muting is ONLY permitted during the upstroke (die opening portion of the cycle).*

Failure to comply with these instructions will result in death or serious injury.

NOTICE

Safety of palletizers and depalletizers per en 415-4

In the event of a blockage on the entry or exit conveyor (for example a stationary pallet in the detection field of the light curtain), the muting shall be disabled and the machine shall be stopped.

A manual control, powering only the required conveyor, shall permit the blockage to be removed.

Restart of the machine shall only be possible by voluntary action once safe condition has been reached.

9.2. Muting inputs

The FF-ST is fitted with two muting inputs. A minimum of two sensors are used to generate the muting sequences. These two sensors may be ultrasonic sensors, photoelectric controls, limit switches or inductive proximity sensors.

These 2 inputs accept relay or static (solid state) sensors type. Sensors with static (solid state) output can be PNP or NPN type (automatic recognition). 2-wire sensors are also accepted. Contact should be open when no object is detected. A muting sequence is initiated by the successive closure of both muting sensor outputs, and interrupted upon the first sensor release. Correct operation of the sensors is monitored at each muting sequence and any sensor failure prevents the muting from being performed.

The muting sensors must reliably detect the manufactured part or the tool initiating and interrupting the muting sequence. They must be correctly connected and positioned, in order to avoid undesired muting or potentially hazardous conditions for the operator.

When sequence conditions are met, the FF-ST allows the machine to operate during the muting sequence.

Muting sequences

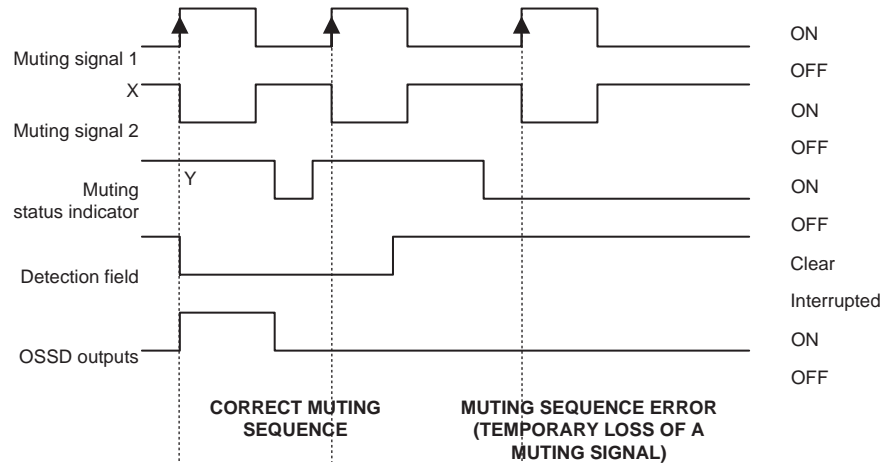

X, Y: no time limitation

WARNING

Improper muting sensor connection

- The FF-ST does not have a minimum timing condition between the 2 muting sensor inputs. Therefore, a cross-fault between these 2 inputs will only be detected if muting sensors outputs have opposite polarities.
- Care should be taken to connect two independent muting signals to these two inputs and to run the sensors connections in separate cables.

Failure to comply with these instructions could result in death or serious injury.

NOTICE

Timing conditions

The muting sequence starts 50 ms after reception of the second muting sensor signal.

There is no timing condition between both muting inputs.

The muting sequence duration is not limited by design. Connection of an external timer to one of the muting inputs, is recommended when a limitation is required.

Detected failures

The following failures are detected and prevent a muting sequence from starting: absence of one or both muting sensors, permanent short-circuit on one of the SM inputs.

CAUTION

Fuses protection

The muting inputs must be protected by an external 0.5 A fuse.

Failure to comply with these instructions may result in product damage.

For input features, see chapter "Specifications".

Wiring information and application notes are given in annex.

10. TEST AND CONTROLS

Operational test with the test rod

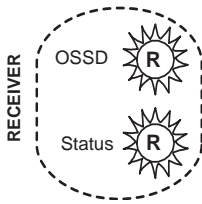
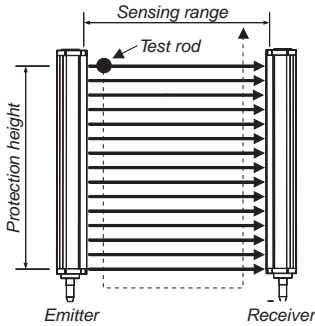

10.1. Operational test

To ensure operational readiness, perform the operational test at regular intervals and every time the light curtain is repaired or the installation is changed. The test should be run with the machine OFF. The operational test consists of passing an opaque test rod through the sensing field to ensure the light curtain will detect it. The sensing function of the light curtain shall be actuated by moving the relevant test rod at a maximum speed of 2.5 m/s.

The test rod should be moved all along the protection field, on the emitter side and on the receiver side in order to verify that the desired resolution is selected. During this, the red "OSSDs" indicator and the red "Status" indicator on the receiver should always be ON both.

The test rod is included with the FF-ST units for resolutions less than 40 mm. For higher resolutions, an object with a diameter corresponding to the light curtain resolution shall be used as the test rod.

10.2. Commissioning check-list

First power up of the FF-ST safety light curtain:

- Make sure the green "OSSDs" LED is ON and that the machine can operate (the FSD relays driven by the light curtain OSSD outputs shall be ON).

When manual restart is selected, press and release the restart push-button:

- Make sure the FF-ST goes to the green condition and that the machine can operate (the FSD relays driven by the light curtain OSSD outputs shall be ON).
- Make sure the restart push-button is installed outside of the dangerous area (not accessible from the inside) and located in a place offering a clear view of the protected area.

When muting is setup, start a muting sequence:

- Make sure the yellow "Status" LED (located on the FF-ST Receiver) illuminates, and interrupt the FF-ST beams with the test rod during the muting sequence. Verify the FF-ST outputs remain ON (the FSD relays driven by the light curtain OSSD outputs shall be ON).
- If the FF-ST outputs are off, make sure the muting sensors are successively actuated. If this is not enough to return to normal operation, check the connections of the muting sensors to the light curtain muting inputs.

Outside a muting sequence:

- Interrupt the FF-ST beams with a test rod, and make sure the FF-ST goes to the RED condition (the FSD relays driven by the light curtain OSSD outputs shall be OFF).

Maintenance operations:

- If the FF-ST receiver has to be changed, make sure the exact same part number is used for replacement.
- Perform the same test sequence after any installation modification.

11. CLEANING

The FF-ST Series light curtains are designed to operate in harsh industrial environments. Exposure to dirt, dust, grease, and oil are unavoidable in these harsh environments. Periodically clean the emitter/receiver units. This section provides specific, step by step, instructions on the proper cleaning techniques for the FF-ST Series emitters and receivers.

Using a dry cloth

Clean dust or loose, dry dirt from the emitter and receiver units using a soft, clean, non-abrasive cloth.



WARNING

Power applied to machine control system

Turn off and disconnect power from FF-ST Series light curtain and machine.

Failure to comply with these instructions could result in death or serious injury.

1. Turn off and disconnect power to both the light curtain and the machine.
2. Gently wipe the soiled areas with a soft, clean, non-abrasive cloth. Do not rub hard to prevent scratching the plastic front plate or finish. If the dirt will not wipe off with a dry cloth, clean units with a soap and water solution. See chapter "Using Soap and Water" below.
3. Connect power to the machine and light curtain.
4. Perform the operational test to ensure proper functional readiness.

CAUTION

FF-ST series light curtain front plate and finish damage

Gently wipe soiled areas with soft, clean, non-abrasive cloth. To prevent scratching clear plastic front plate or finish, do NOT rub hard.

Failure to comply with these instructions may result in product damage.

Using soap and water

1. Turn off and disconnect power to the light curtain and machine.
2. Dampen a soft, clean, non-abrasive cloth in the solution of mild soap and water. Squeeze excess solution from the cloth.
3. Wipe the soiled areas gently with the damp cloth. Do not rub hard to prevent scratching the clear plastic front plate.
4. Rinse the cloth in clean water and gently wipe off any excess soap.
5. Dry the emitter and receiver with a soft, dry, non-abrasive cloth. Ensure there is no moisture left on the emitter and receiver units before power is applied.
6. Connect power to the machine and light curtain.
7. Perform the operational test to ensure proper functional readiness.

ANNEX A

SPECIFICATIONS TABLE

Operating characteristics		
Resolution (min. object detection size, mm)	14, 26, 38	18, 30, 42, 54, 80
Nominal Scanning Range (m)	0 ... 3.5	0.25 ... 10
Angle of Divergence	max. $\pm 2.5^\circ$ above 3 m (as per IEC/EN61496-2)	
Emitting Light Source	Infrared, pulsed, 880 nm	
Immunity to Ambient Light	sunlight 20 000 Lux, lamplight 15 000 Lux	
Electrical characteristics		
Power Supply		
Supply voltage	24 Vdc ($\pm 20\%$) for the emitter and the receiver (recommended external fuse protection: slow, 2.5 A)	
Power consumption	5 W max. for the emitter, 5 W max. for the receiver	
Safety outputs (OSSDs)		
Output type	2 safety solid state outputs, push-pull / PNP type with Normally Open characteristics	
Response time	See annex C	
Switching capability	350 mA max. at 24 Vdc	
Restart time after power up	> 1 s (automatic mode)	
Restart time after beam release	80 ms (without EDM), 150 ms (with EDM)	
Leakage current	0.25 mA	
Loads impedance	70 Ω min. / 5 k Ω max.	
Voltage drop	< 2.3 Vdc	
Loads turn-on voltage	5 V min. on resistive loads / 7 V min. on inductive loads	
Test pulse width / recurrence	2 pulses (width 200 μ s and 75 μ s), separated by 300 μ s, frequency from 3.3 ms to 8 ms (depending on height)	
Protections	Short-circuits and cross-faults, overloads (0.4 A max. / 0 Vdc; 0.9 A max. / 24 Vdc), reversed polarity, micro-cut-off 10 ms (100 % voltage breakdown, 10 Hz)	
Max. cable length	100 m / 328.08 ft (capacitance: 100 nF)	
Inputs		
External contact type	Relay contact, or static (solid state) PNP or static (solid state) NPN (automatic recognition - no push-pull output allowed)	
Filtering time	20 ms by default, 150 ms on the EDM input	
Voltage switching thresholds (High/Low)	14.5 Vdc min. / 4.5 Vdc (comply with IEC 61131-2, for type 2 sensors)	
Input current (high/low)	20 mA / 10 mA at 24 Vdc	
Max. voltage	29 Vdc	
Muting inputs	No timing coincidence required	
Muting duration	Illimited by design (may be reduced through an auxiliary timer)	
Environmental characteristics		
Operating Temperature Range	0 $^\circ$ C to 55 $^\circ$ C	
Relative humidity	95%	
Storage Temperature Range	-20 $^\circ$ C to 75 $^\circ$ C	
Sealing	IP 65	
Vibrations	IEC/EN 61496-1: 10 to 55 Hz frequency range, 1 octave/ min.sweep rate, 0.35 mm \pm 0.05 amplitude, 20 sweeps per axis, for 3 axes	
Shocks	IEC/EN 61496-1: 15 G - 11 ms - 3 per axis, for 3 axes	
Bumps	IEC/EN 61496-1: 10 G - 16 ms - 1000 per axis, for 3 axes	

ANNEX B

DIMENSIONS - MATERIALS

Dimensions (mm)

Materials

- Housing Aluminium alloy
- End caps Zamak
- Window PMMA (Polymethylmethacrylate)

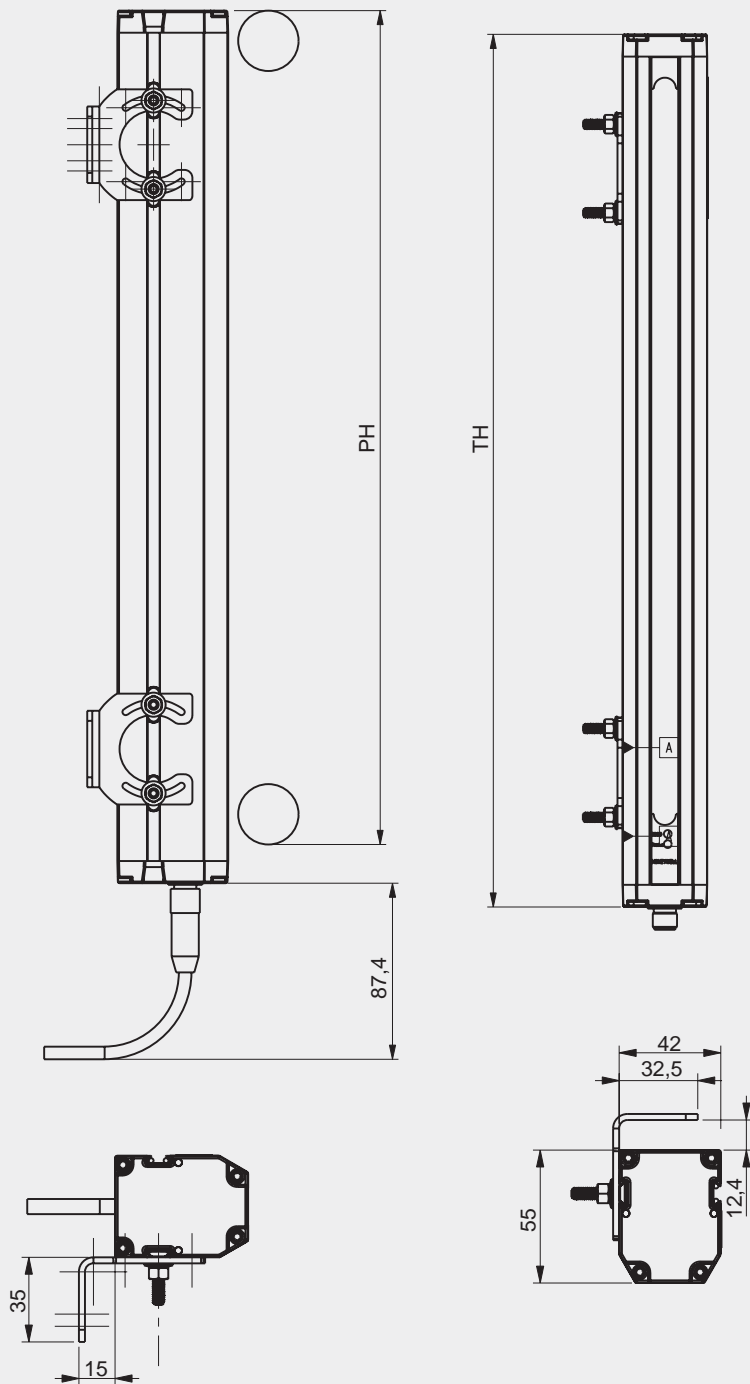

ANNEX C

WEIGHT, PROTECTION HEIGHTS, RESPONSE TIMES

Protection Heights PH (mm), Total Heights (mm) and Weights (kg)																		
Models	Resolution	Max. undetected object size	02	03	04	05	06	07	08	09	10	11	12	13	14	15	16	18
Protection Heights PH (mm)																		
FF-ST4A ... S, T, U, V	14	0																
FF-ST4A ... W, X, Y, Z	26	10	206	302	398	494	590	686	782	NA	974	NA	1166	NA	1358	NA	NA	NA
FF-ST4A ... A1, B1, C1, D1	38	22																
FF-ST4B ... S, T, U, V	18	0																
FF-ST4B ... W, X, Y, Z	30	6	210	306	402	498	594	690	786	NA	978	NA	1170	NA	1362	NA	NA	NA
FF-ST4B ... A1, B1, C1, D1	42	18																
FF-ST4C ... S, T, U, V	30	0																
FF-ST4C ... W, X, Y, Z	54	18	222	318	414	510	606	702	798	894	990	1086	1182	1278	1374	1470	1566	1758
FF-ST4C ... A1, B1, C1, D1	80	42																
Total heights TH (mm)			242	338	434	530	626	722	818	914	1010	1106	1202	1298	1394	1490	1586	1778
Weights (kg)			2	2.35	2.75	3.1	3.55	3.9	4.3	4.7	5	5.4	5.8	6.25	6.65	7	7.4	8.15

Response times (ms)																		
Models	Resolution	Max. undetected object size	02	03	04	05	06	07	08	09	10	11	12	13	14	15	16	18
FF-ST4A ... S, T, U, V	14	0	11	12	12.5	13	14	14.5	15.5	NA	16.5	NA	18	NA	19.5	NA	NA	NA
FF-ST4B ... S, T, U, V	18	0	11	12	12.5	13	14	14.5	15.5	NA	16.5	NA	18	NA	19.5	NA	NA	NA
FF-ST4C ... S, T, U, V	30	0	11	12	12.5	13	14	14.5	15.5	16	16.5	17.5	18	19	19.5	20	21	22
FF-ST4A ... W, X, Y, Z	26	10	13.5	14.5	15.5	16	17	18	19	NA	21	NA	23	NA	24.5	NA	NA	NA
FF-ST4A ... A1, B1, C1, D1	38	22	13.5	14.5	15.5	16	17	18	19	NA	21	NA	23	NA	24.5	NA	NA	NA
FF-ST4B ... W, X, Y, Z	30	6	13.5	14.5	15.5	16	17	18	19	NA	21	NA	23	NA	24.5	NA	NA	NA
FF-ST4B ... A1, B1, C1, D1	42	18	13.5	14.5	15.5	16	17	18	19	NA	21	NA	23	NA	24.5	NA	NA	NA
FF-ST4C ... W, X, Y, Z	54	18	13.5	14.5	15.5	16	17	18	19	20	21	22	23	23.5	24.5	25.5	26.5	28.5
FF-ST4C ... A1, B1, C1, D1	80	42	13.5	14.5	15.5	16	17	18	19	20	21	22	23	23.5	24.5	25.5	26.5	28.5

NA: Not Available

ANNEX D

MECHANICAL MOUNTING

Mounting brackets

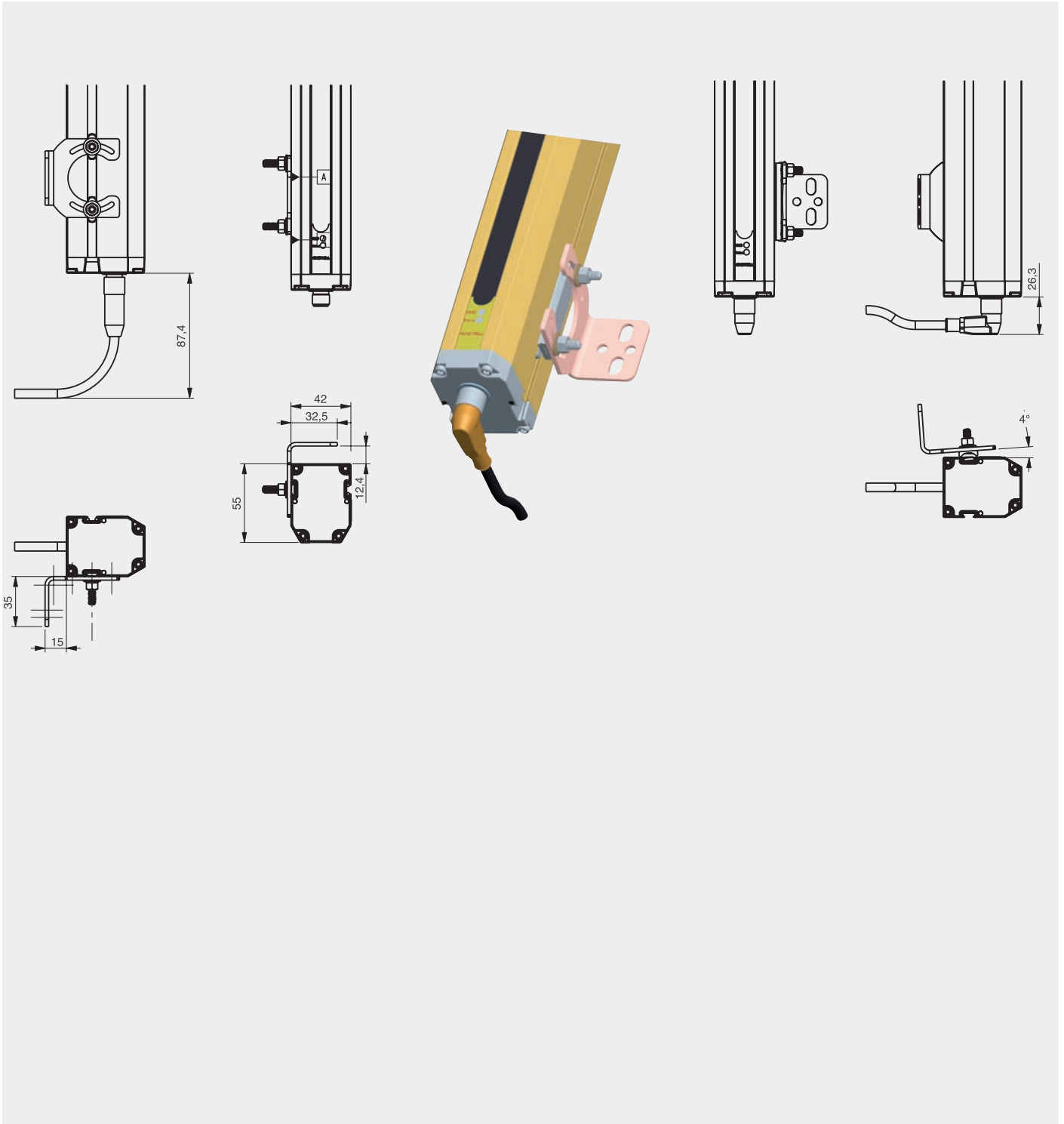

ANNEX E

WIRING DIAGRAMS



WARNING

Strictly adhere to all electrical instructions.

Failure to comply with these instructions could result in death or serious injury.

Emitter



- 1 = brown
- 2 = white (not used)
- 3 = blue
- 4 = black (not used)
- 5 = grey (not used)

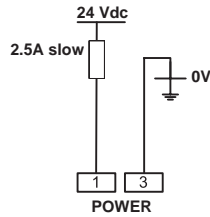

Receiver

Function packages S, W, A1 - AUTO with muting



- 1 = white (not used)
- 2 = brown
- 3 = green
- 4 = yellow
- 5 = grey
- 6 = pink
- 7 = blue
- 8 = red (not used)

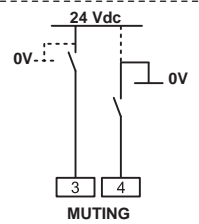
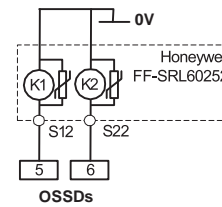
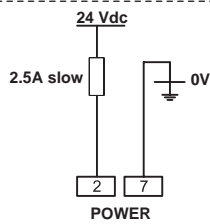

Function packages U, Y, C1 - AUTO/EDM with muting



- 1 = white
- 2 = brown
- 3 = green
- 4 = yellow
- 5 = grey
- 6 = pink
- 7 = blue
- 8 = red (not used)

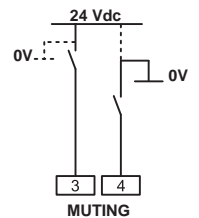
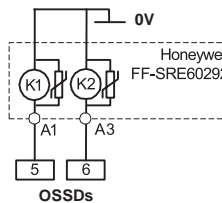
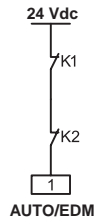
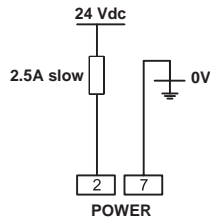

Function packages T, X, B1 - RES/EDM with muting



- 1 = white
- 2 = brown
- 3 = green
- 4 = yellow
- 5 = grey
- 6 = pink
- 7 = blue
- 8 = red (not used)

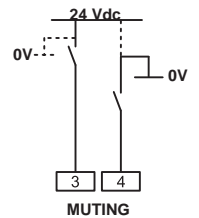
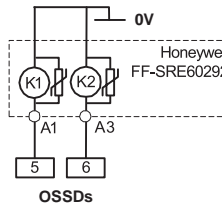
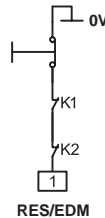
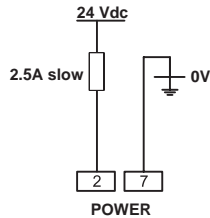

Function packages V, Z, D1 - Selec RES/EDM with muting



- 1 = white
- 2 = brown
- 3 = green
- 4 = yellow
- 5 = grey
- 6 = pink
- 7 = blue
- 8 = red

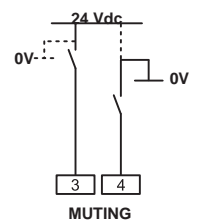
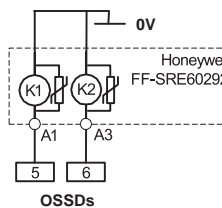
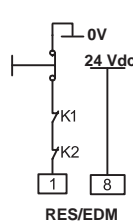
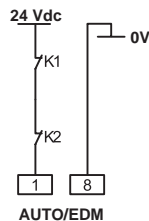
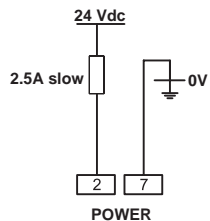

ANNEX F

INDICATORS AND TROUBLESHOOTING

Contact your local Honeywell representative if one of the following conditions is not met:

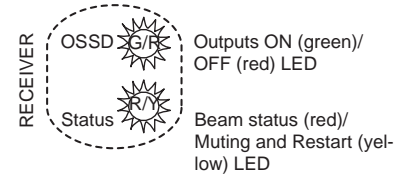
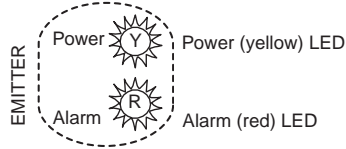
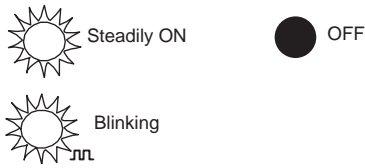

Symptoms		Root causes and remedies	
1	Power OSSD Alarm Status	<p>Ensure external fuse is not blown.</p> <p>Ensure supply voltage and polarity are correct.</p> <p>Ensure electrical power connections are secure and correct.</p>	
2	Power OSSD Alarm Status	<p>Press and release the restart push-button and/or check the final switching devices (relays K1 and K2).</p> <p>If symptoms persist, make sure the wired polarity of the restart input(s) is in accordance with the wiring diagrams.</p>	
3	Power OSSD Alarm Status	<p>Normal operation – the beam is clear.</p>	
4	Power OSSD Alarm Status	<p>Replace the emitter unit by a new one of the same resolution and protection height.</p>	
5	Power OSSD Alarm Status	<p>Normal operation, the beam is interrupted or misaligned.</p> <p>Clear the detection field or realigned the emitter and the receiver.</p> <p>If symptoms persists, replace the emitter unit by a new one of the same resolution and protection height.</p>	
6	Power OSSD Alarm Status	<p>Normal operation – Switch power off – Remove any short-circuit of the OSSD output(s) – Restore power.</p>	
7	Power OSSD Alarm Status	<p>The optical alignment is not optimized or the device is detecting dust or dirt accumulation on the front window – Re-align the emitter with the receiver or clean the device front window.</p>	
8	Power OSSD Alarm Status	<p>Reception of two infrared emissions will maintain the light curtain in a lockout condition. To go back to normal operation, switch the power off and eliminate the interferences by reversing systems emitting orientation or by using opaque screens. Then, restore the power.</p>	
9	Power OSSD Alarm Status	<p>Normal operation - Muting in progress.</p>	

ANNEX G

APPLICATION NOTE 1: MUTING ON A CONVEYOR USING TWO MUTING SENSORS

In the following example, two photo-electric controls are used to recognize the passing material (pallets, vehicles, etc.) according to the material's length and speed.

⚠ DANGER

Improper muting sensor position

- The muting sensors must be positioned in such a way that the activation of the muting function is not possible with the accidental passing of a person.
- The additional mechanical guardings must be designed and installed in such a way that people cannot enter the dangerous area without being detected by the safety light curtain and the auxiliary sensors, if relevant. In particular, a person following parts vehiculed towards the dangerous zone must be detected when interrupting the safety light curtain detection field. The design and the installation of these additional mechanical guardings must comply with the requirements of the corresponding standards.
- Moreover, it may be necessary to provide additional protection to maintain the protection level provided by the safety light curtain. Hard guards or additional presence sensing devices such as safety mats, may be used to ensure the operator is either forced to move through the sensing field to enter the danger zone, or forced to stand on the sensing area inside the danger zone.

Failure to comply with these instructions will result in death or serious injury.

NOTICE

Safety of palletizers and depalletizers per en 415-4

In the event of a blockage on the entry or exit conveyor (for example a stationary pallet in the detection field of the light curtain), the muting shall be disabled and the machine shall be stopped.

A manual control, powering only the required conveyor, shall permit the blockage to be removed.

Restart of the machine shall only be possible by voluntary action once safe condition has been reached.

Sensor connection

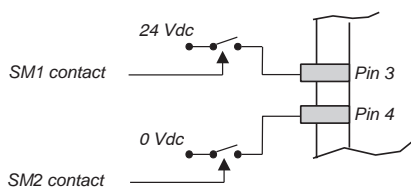

Sensor installation

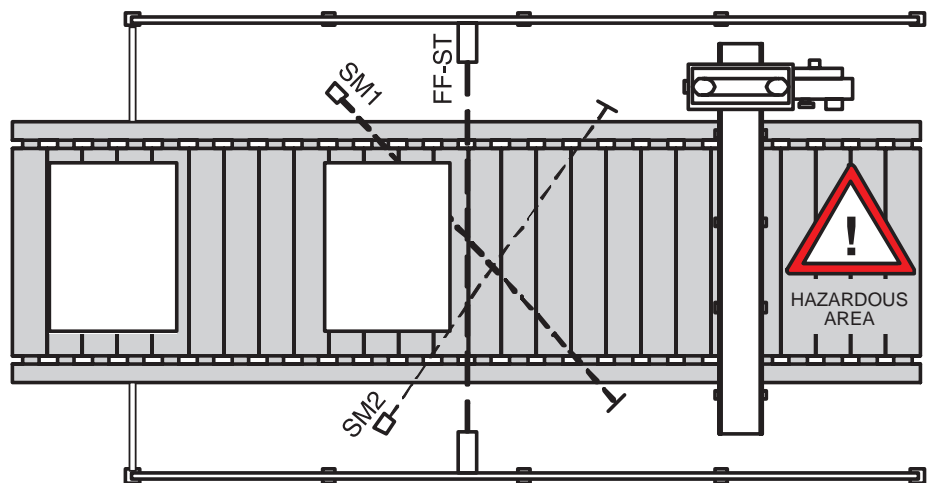

Sensor timing diagram

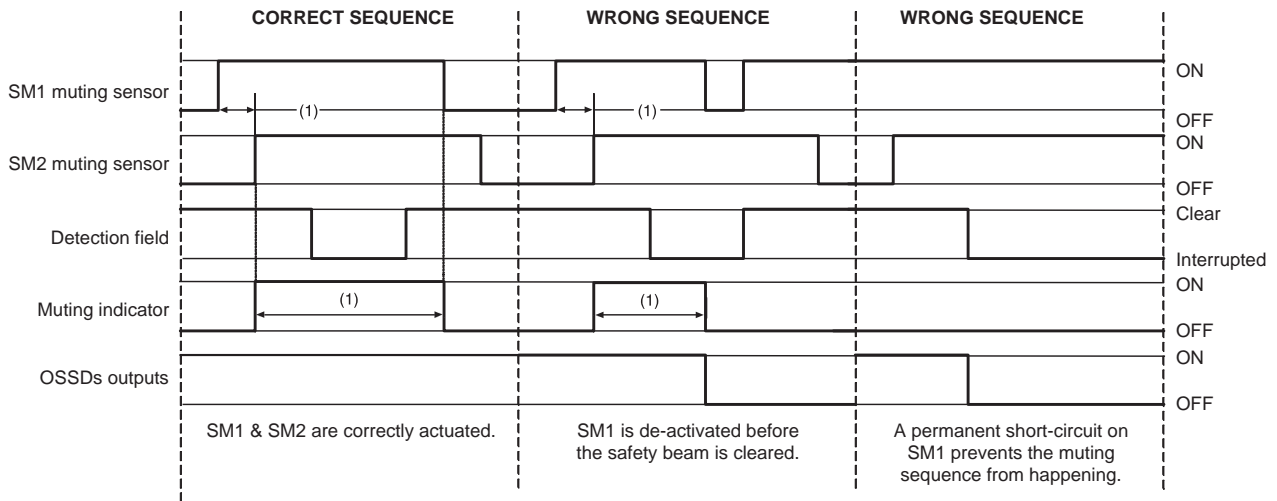

(1): No time limitation

⚠ WARNING

Improper installation

- The distance between SM1 & SM2 sensors must not allow a person to easily actuate both sensors to avoid the unexpected start of a muting sequence.
- The crossing point of both photoelectric control beams shall be located inside the hazardous area.

Failure to comply with these instructions will result in death or serious injury.

NOTICE

Improper installation

The muting sequence ends upon first muting sensor de-activation (SM1 if the object enters the hazardous area).

APPLICATION NOTE 2: MUTING ON A CONVEYOR USING FOUR SENSORS

The following example is a variation of the previous application, where 4 sensors are used to start a muting sequence whatever the direction of the movement of the objects. These sensors could also be limit switches, ultrasonic sensors, photoelectric controls or inductive proximity sensors (correct operation of these sensors is monitored by the FF-ST). The muting of the FF-ST is allowed when the detected objects enter and leave the dangerous area. This installation is recommended on applications where the entry and exit points of the material into the dangerous zone are the same.

Improper muting sensor position

⚠ DANGER

- The muting sensors must be positioned in such a way that the activation of the muting function is not possible with the accidental passing of a person.
- The additional mechanical guardings must be designed and installed in such a way that people cannot enter the dangerous area without being detected by the safety light curtain and the auxiliary sensors, if relevant. In particular, a person following parts vehiculed towards the dangerous zone must be detected when interrupting the safety light curtain detection field. The design and the installation of these additional mechanical guardings must comply with the requirements of the corresponding standards.
- Moreover, it may be necessary to provide additional protection to maintain the protection level provided by the safety light curtain. Hard guards or additional presence sensing devices such as safety mats, may be used to ensure the operator is either forced to move through the sensing field to enter the danger zone, or forced to stand on the sensing area inside the danger zone.

Failure to comply with these instructions will result in death or serious injury.

NOTICE

Safety of palletizers and depalletizers per en 415-4

In the event of a blockage on the entry or exit conveyor (for example a stationary pallet in the detection field of the light curtain), the muting shall be disabled and the machine shall be stopped.

A manual control, powering only the required conveyor, shall permit the blockage to be removed.

Restart of the machine shall only be possible by voluntary action once safe condition has been reached.

Sensor connection

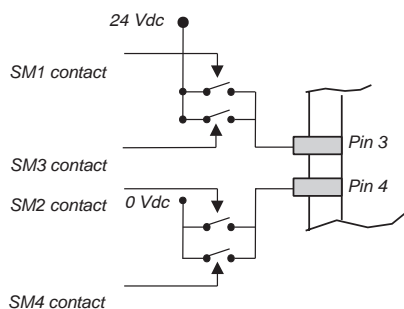

Sensor installation

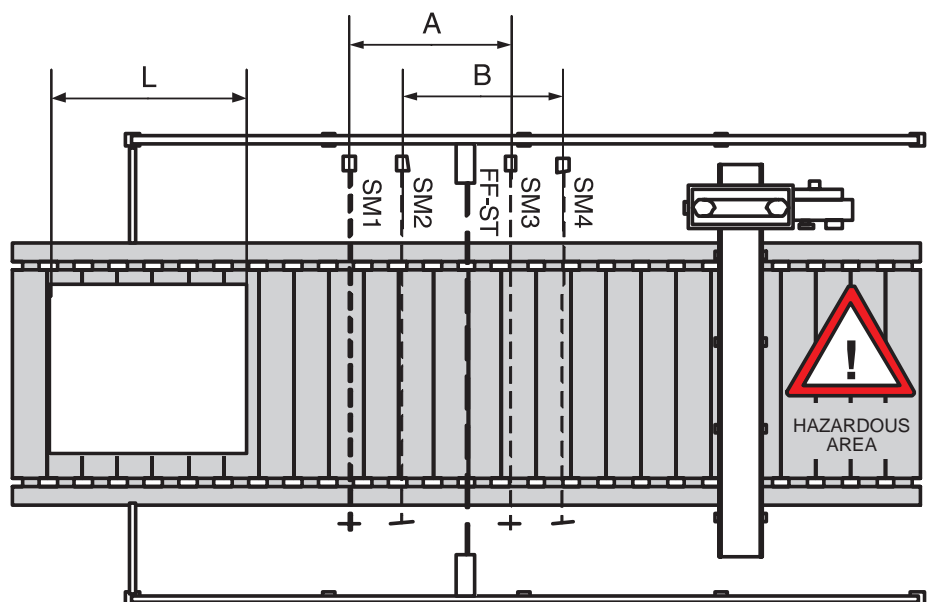

Sensor timing diagram

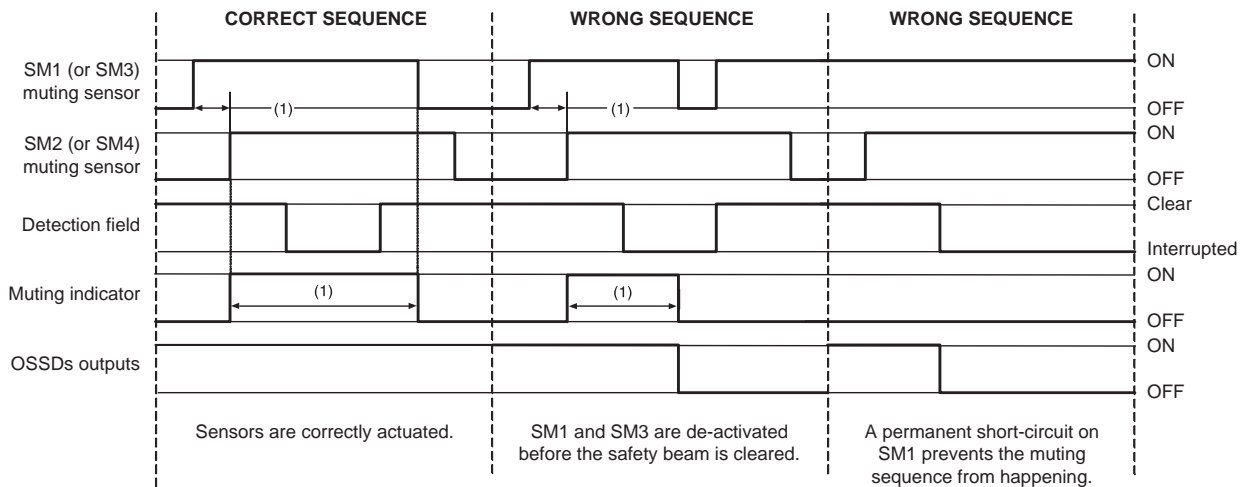

(1): No time limitation

⚠ WARNING

Improper installation

The distance between SM1 & SM2 sensors must not allow a person to easily actuate both sensors to avoid the unexpected start of a muting sequence.

Failure to comply with these instructions will result in death or serious injury.

NOTICE

Improper installation

- The muting sequence ends upon first muting sensor de-activation (SM3 if the object enters the hazardous area).
- Distances A and B between respectively SM1 & SM3 and SM2 & SM4 shall be smaller than the object length L.

APPLICATION NOTE 3: MUTING THE SAFETY LIGHT CURTAIN DURING THE UPSTROKE OF A MECHANICAL POWER PRESS CYCLE

In this example, two limit switches SM1 & SM2 are used to start and stop a muting sequence (on a different machine, the sensors could also be photoelectric controls, ultrasonic sensors or inductive proximity sensors). Correct operation of these sensors is monitored by the FF-ST.

As soon as the press tool reaches the Bottom Dead Center (BDC), the SM sensors are activated by the rotation of the rotating disk cam and start the muting sequence. The limit switches keep their position till the press tool reaches the Top Dead Center (TDC). The rotation of the rotating disk cam releases both limit switches and interrupt the muting sequence.

⚠ DANGER

Mechanical power press operating in reverse mode

- The Honeywell muting function shall only be used during non-hazardous portion of the mechanical power press cycle, i.e. during die opening when the press is running forward (crankshaft is running clockwise).
- If it is foreseeable that the press may be run in reverse or the press crankshaft rotation direction changed, even accidentally, do NOT install the Honeywell muting system on the press.
- The muting function provided by the Honeywell product DOES NOT recognize the crankshaft rotation direction (clockwise or counterclockwise). If muting is installed to operate during the upstroke when running forward (clockwise), then muting should not occur during the downstroke when running reverse (counterclockwise). Muting is ONLY permitted during the upstroke (die opening portion of the cycle).

Failure to comply with these instructions will result in death or serious injury.

Sensor connection

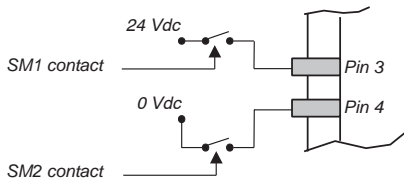

Sensor installation

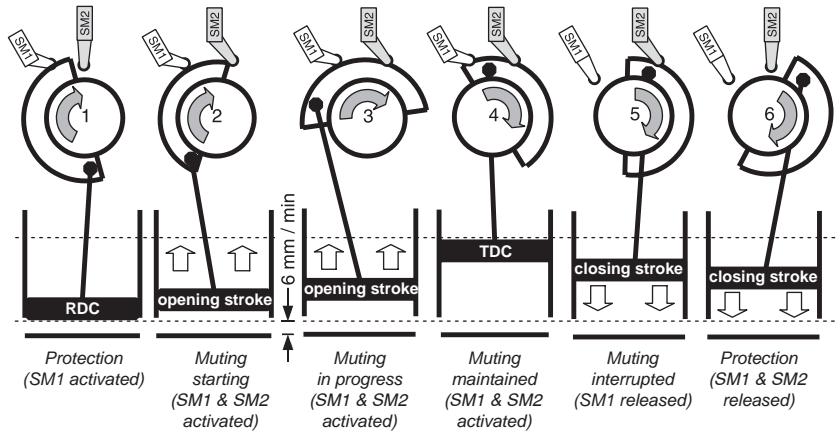

Sensor timing diagram

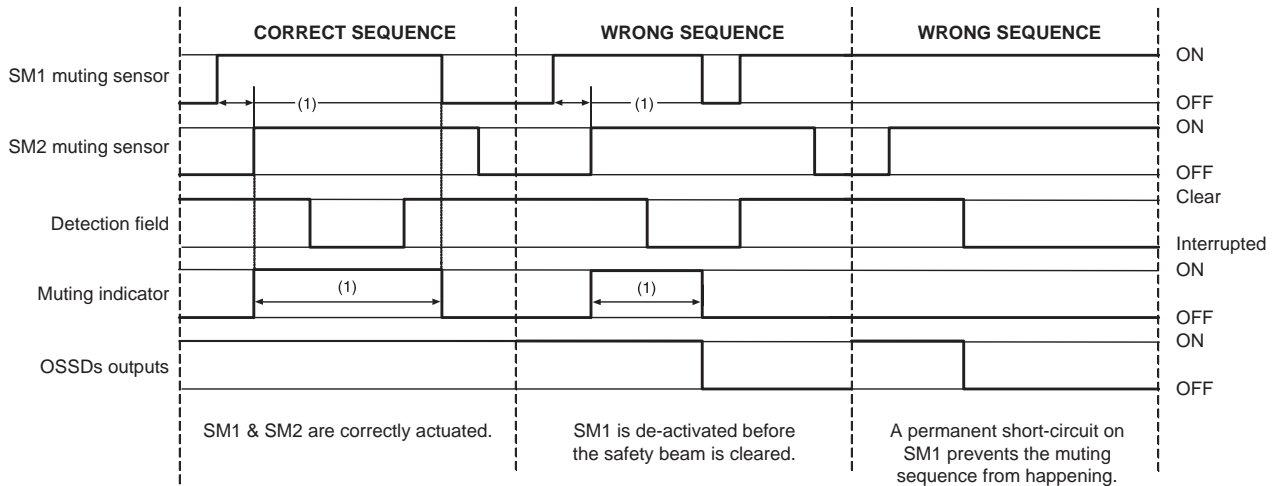

(1): No time limitation

⚠ WARNING

Incorrect installation

- The position of the second sensor SM2 cam must be adjusted so that the SM2 sensor is activated when the press tool reaches the Bottom Dead Center (or when the press tool reaches a position at 6 mm above the Bottom Dead Center). At this position, the operator is no more exposed to a dangerous situation, and the starting of the muting sequence avoids damaging the part if the detection field of the light curtain is unexpectedly interrupted.
 - Do NOT mute the light curtain during the closing stroke of the press.
- Failure to comply with these instructions could result in death or serious injury.**

NOTICE

Improper installation

The muting sequence ends upon first muting sensor de-activation (SM1).

APPLICATION NOTE 4: HOW TO LIMIT THE MUTING SEQUENCE DURATION?

On the following application, sensors A and B are located at a distance from the light curtain detection field so that the muting sequence starts before the object interrupts the light curtain beams. Sensor E is located at a distance such as the muting sequence is interrupted once the light curtain detection field is cleared.

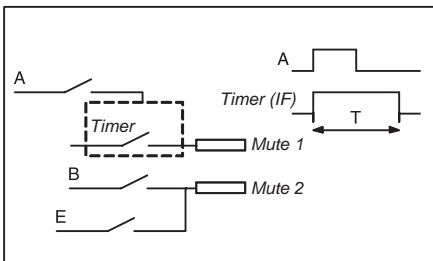
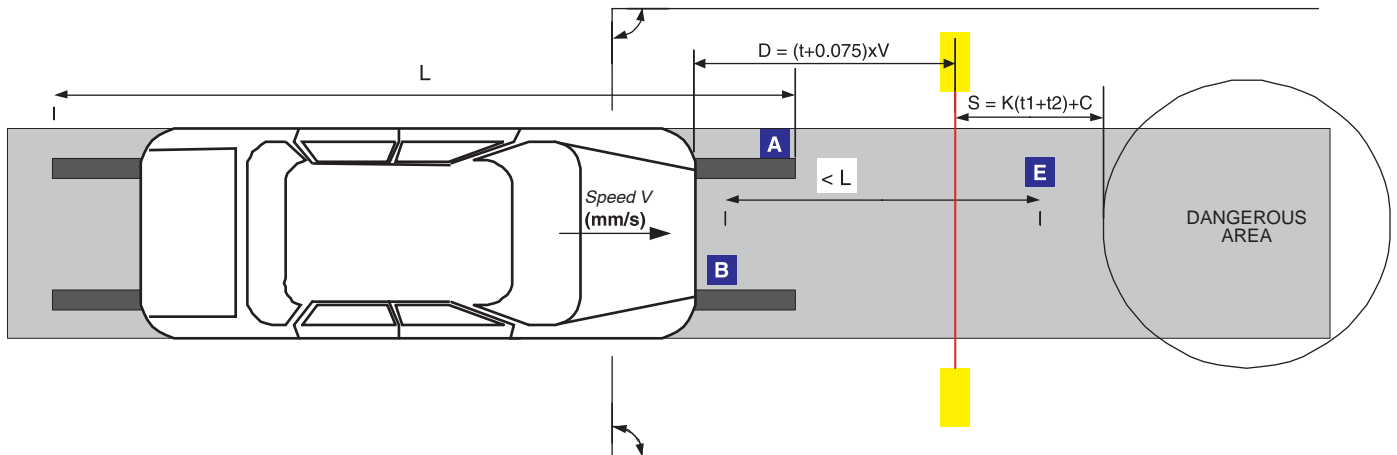

A timer (Dold BC7935, function "IF") driven by sensor A (or the second sensor that initiates the muting sequence), can be used to limit the duration of the muting sequence.

NOTICE

Safety of palletizers and depalletizers per en 415-4

In the event of a blockage on the entry or exit conveyor (for example a stationary pallet in the detection field of the light curtain), the muting shall be disabled and the machine shall be stopped.

A manual control, powering only the required conveyor, shall permit the blockage to be removed.

Restart of the machine shall only be possible by voluntary action once safe condition has been reached.

ANNEX H CE DECLARATION OF CONFORMITY

Honeywell

Honeywell
 B.P. 81
 21, Chemin du Vieux Chêne - ZIRST
 38243 Meylan Cedex - France
 Phone: (33) 4 76 41 72 00
 Fax: (33) 4 76 41 72 56



HONEYWELL GRENOBLE

CE declaration of conformity

We: Honeywell
 ZIRST B.P. 81
 21, chemin du Vieux Chêne
 38240 Meylan Cedex - France

Declare: that the protective equipment catalogued:
Safety Light Curtain FF-ST4 Series
 To which this declaration relates is in conformity with the technical requirements of the standards and the provisions of the essential requirements of the Directives detailed below.
 We implement a Quality Assurance system ISO 9001: 2000 certified by QMI (certificate number CERT-0017143-025033).

Directives:

- Machinery Directive 98/37/EC
- Low Voltage Directive 2006/95/EC
- Electromagnetic Compatibility Directive 2004/108/EC

Standards: EN 61496-1: Safety of Machinery – Electrosensitive Protective Equipment – part 1 : General requirements and tests.
 EN 61496-2: Safety of Machinery - Electrosensitive Protective Equipment – part 2 : Active Optoelectronic Protective Devices.
 EN 61508 : Functional Safety of Electrical/Electronic/Programmable Electronic Safety-Related Systems.

Safety category: Type 4 as per EN 61496-1 and EN 61496-2
 SIL 3 as per EN 61508

The conformity to the European directives of the type model from the series above has been certified by:

Notified body: Institut National de Recherche et de Sécurité (INRS)
 Avenue de Bourgogne – B.P. 27
 54501 Vandœuvre Cedex – France

Certificate number: 0070 510 0327 06 07 **Date of certificate:** 15/06/2007

Meylan, 15/06/2007 Christophe LE MOING Laurent VIGNES
 Research and Development Manager General Manager



Honeywell SA. - Capital 16.758.614 €
 SIREN 562 004 796 - APE 332B
 Immeuble «le Mercure»
 Parc Technologique de Saint Aubin - Route de l'Orme - 91190 Saint Aubin
 R.C.S. Corbeil-Essonnes B 562 004 796 - Phone: (33) 01 60 19 80 40 - Fax: (33) 01 60 19 81 73

Honeywell
No. 1668 Tian yin Road
Nanjing Science Park
Jiangning District
Nanjing, 211100, P.R. China
Phone: 86 25 5183 2576
Fax: 86 25 52715207



Certificate number QEC26820

HONEYWELL NANJING

CE declaration of conformity

We: Honeywell
No. 1668 Tian yin Road
Nanjing Science Park
Jiangning District
Nanjing, 211100, P.R. China

Declare: that the protective equipment catalogued:

Safety Light Curtain FF-ST4 Series

To which this declaration relates is in conformity with the technical requirements of the standards and the provisions of the essential requirements of the Directives detailed below.
We implement a Quality Assurance system **ISO9001** certified by **SAI** (certificate number **QEC26820**).

Directives:

- **Machinery Directive 98/37/EC**
- **Low Voltage Directive 2006/95/EC**
- **Electromagnetic Compatibility Directive 2004/108/EC**

Standards: **EN 61496-1**: Safety of Machinery – Electrosensitive Protective Equipment – part 1: General requirements and tests.
EN 61496-2: Safety of Machinery – Electrosensitive Protective Equipment – part 2: Active Optoelectronic Protective Devices.
EN 61508: Functional Safety of Electrical/Electronic/Programmable Electronic Safety-Related Systems

Safety category: Type 4 as per EN 61496-1 and EN 61496-2
SIL 3 as per EN 61508

The conformity to the European directives of the type model from the series above has been certified by:

Notified body: **Institut National de Recherche et de Sécurité (INRS)**
Avenue de Bourgogne – B.P. 27
54501 Vandœuvre Cedex – France

Certificate number: 0070 510 0327 06 07

Date of certificate: 26/06/2007

Nanjing Factory

Quality Manager

General Manager

POINT OF SALES

ARGENTINA

Honeywell SAIC
Phone: 54 11 4383 7012
Fax: 54 11 4325 6470

AUSTRIA

Geva
Phone: 43 0225 28 55 520
Fax: 43 0225 24 88 60

Sensorwell
Phone: 43 0316 40 33 01 16
Fax: 43 0316 40 33 01 10

AUSTRALIA

Honeywell Pacific Inc, Melbourne
Phone: 613 9420 5555
Fax: 613 9420 5607

Ramelec
Phone: 1300 309 150
Fax: 1300 309 152
sales@ramelec.com.au
www.ramelec.com.au

BELGIUM

Sention BVBA
Phone: 32 (475) 94 99 55
Fax: 32 (3) 828 51 22

Teleson N.V.
Phone: 32 2 469 03 36
Fax: 32 2 469 12 78
www.teleson.be

BRAZIL

Honeywell Do Brazil & CIA
Phone: 55 11 865 2055
Fax: 55 11 865 3894

Farnell-Newarkinone
Phone: 55 11 4066 9400
Fax: 55 11 4066 9410
vendas@farnell-newarkinone.com
www.farnell-newarkinone.com.br

CANADA

Ideal Supply Co Ltd
Phone: 705 728 5911
www.idealsupply.com

Xtronics (1)
Phone: 1 905 660 0555
Fax: 1 905 660 0559

CHINA

Honeywell (Tianjin) Ltd, Shang-hai (2)
Phone: 86 21 623 70 237
Fax: 86 21 623 71 237

Honeywell Ltd, Hong Kong
Phone: 852 2331 9133
Fax: 852 2331 9998

CZECK REPUBLIC

Honeywell
Phone: 420 602 364 696
Fax: 420 261 122 691

Atrolat
Phone: 420 558 324 566
Fax: 420 558 324 567

DENMARK

Honeywell A/S
Phone: 45 20 60 75 05
Fax: 45 39 55 55 51

FINLAND

Honeywell
Phone: 358 9 3480 101
Fax: 358 9 34801 234

FRANCE

Honeywell SA
Phone: 33 (0)1 60 19 82 68
Fax: 33 (0)1 60 19 81 81
Honeywell Grenoble (Factory) (1)
Phone: 33 (0)4 76 41 72 00
Fax: 33 (0)4 76 41 72 56

BFC Automatism

Phone: 33 (0)3 85 45 81 05
Fax: 33 (0)3 85 45 81 08

Diceep SA (2)
Phone: 33 (0)3 83 29 03 43
Fax: 33 (0)3 83 21 46 13

ETN
Phone: 33 (0)2 32 91 51 51
Fax: 33 (0)2 32 91 51 70

Faure Automatism
Phone: 33 (0)4 75 75 99 00
Fax: 33 (0)4 75 41 30 00

FGET International
Phone: 33 (0)4 72 79 64 15
Fax: 33 (0)4 72 79 64 10

Game (1)
Phone: 33(0)3 76 21 13 72 69
Fax: 33 (0)3 21 13 72 78

Sogedoc
Phone: 33 (0)5 56 40 73 40
Fax: 33 (0)5 56 40 73 41

GERMANY

Honeywell AG
Phone: 49 69 80 64 559
Fax: 49 69 80 64 97 559

A. Hock (1)
Phone: 49 69 8064 303
Fax: 49 69 8064 289

Elblinger Elektronik
Phone: 48 (61) 894 69 90
Fax: 48 (61) 894 69 99

Löffelhardt
Phone: 49 (711) 5207 228
Fax: 49 (711) 5207 301

Schweiger
Phone: 49 (8104) 897-0
Fax: 49 (8104) 897-90

INDIA

Honeywell
Phone: 91 22 641 0897
Fax: 91 22 640 9513

ITALY

Gardinet s.r.l.
Phone: 39 045 79 50 395
Fax: 39 045 79 52 006

JAPAN

Honeywell Japan Inc
Phone: 81 3 67 6730 7208
Fax: 81 3 6730 7230

Aitech Engineering Corporation
Phone: 81 3 5999 2277
Fax: 81 3 5999 2200

KOREA

Honeywell Korea Co. Ltd
Phone: 822 799 6114 5
Fax: 822 792 9011 2
www.honeywell.co.kr

MALAYSIA

Honeywell
Phone: 037 958 4988
Fax: 037 958 8922

MEXICO

Honeywell
Phone: 52 5 259 19 66
Fax: 52 5 570 2985

NETHERLANDS

Honeywell
Phone: 31 20 5656 911
Fax: 31 20 5656 201
Ehrbecker Schiefelbusch
Phone: 31 76 578 2828
Fax: 31 76 581 2716
www.elektro.nl

Teleson B.V.
Phone: 31 30 263 1000
Fax: 31 30 263 1011
www.teleson.nl

NEW ZEALAND

Honeywell
Phone: 64 9 623 5050
Fax: 64 9 623 5060

Teltherm Instruments Ltd
Phone: 64 9 63 30 040
Fax: 64 9 63 30 012

mark@teltherm.co.nz
www.teltherm.co.nz

Vectron Technologies
Phone: 64 9 579 4046
Fax: 64 9 579 4164

POLAND

Honeywell
Phone: 48 22 606 09 00
Fax: 48 22 606 09 01

PORTUGAL

Antonio Moutinho & C
Phone: 351 22 536 3060
Fax: 351 536 4645

ROMANIA

Honeywell
Phone: 40 1 211 0076
Fax: 40 1 210 3375

SINGAPORE

Honeywell PTE Ltd
Phone: 656 355 2828
Fax: 656 445 3033

SLOVAK REPUBLIC

Honeywell
Phone: 421 7 5824 7403
Fax: 421 7 5824 7415

SOUTH AFRICA (REPUBLIC OF)

Honeywell
Phone: 27 11 805 1201
Fax: 27 11 315 2197

Atlas Industrial Systems (2)
Phone: 016 981 7843
Fax: 016 933 6552

SOUTH KOREA

Honeywell
Phone: 82 2 799 6167
Fax: 82 2 792 9013

SPAIN

ASP Electronic sl (2)
Phone: 34 916 619 795
Fax: 34 916 624 339

AA - Commercial Arturo Abos sl
Phone: 34 913 803 815
Fax: 34 917 773 351

Instituto Automatización sl
Phone: 34 934 542 006
Fax: 34 934 237 059

SWEDEN

Honeywell
Phone: 46 8 775 55 00
Fax: 46 8 775 56 00

RS Components
Phone: 46 8 445 89 00
Fax: 46 8 687 11 52

Farnell
Phone: 46 8 730 50 00
Fax: 46 8 835 262
www.farnell.co.uk/sweden

Kamic
Phone: 46 54 57 01 20
Fax: 46 54 56 25 13
kamic.karlstad@kamic.se
www.kamic.se

SWITZERLAND

Honeywell
Phone: 41 1 855 24 40
Fax: 41 1 855 24 45

Ymatron
Phone: 41 44 855 23 83
Fax: 41 44 855 23 81

UNITED KINGDOM

Honeywell
Phone: 44 1698 481 000
Fax: 44 1698 481 014

Parmley Graham
Phone: 0161 428 6662
Fax: 0161 428 1376
stockport@parmley-graham.co.uk

UNITED STATES

Honeywell Sensing & Control (2)
Phone: 1 800 537 6945
Fax: 1 815 23 6545

Honeywell (Florida)
Phone: 305 805 8188 ext. 281
Fax: 305 889 1009
rene.zurita@honeywell.com

AA Electric-WI
Phone: 800 558 70 33
info@aa-electric.com

Allied Electronics
Phone: 800 433 5700
nsc\$manager@alliedelec.com

Arrow Electronics
Phone: 800 833 3557
feedback@arrow.com

Becker Electric
Phone: 800 879 0500
general@beckerelectric.com

CAM RPC Electronics
Phone: 800 724 0675
lynda@camrpc.com

Controller Service and Sales
Phone: 508 513 1000
sales@controllerservice.com

Control Components Inc
Phone: 800 489 4145
sales@controlcomponentsinc.com

Carlton-Bates Company
Phone: 866 600 6040
cbsales@carlton-bates.com

Crescent Electric
Phone: 815 747 3145
webmaster@casco.com

Electric Switches Premier
Phone: 800 421 8855
sales@electricswitches.com

Digi-Key Corp.
Phone: 800 344 4539
sales@digikey.com

Electrical Engineering & Equipment Co
Phone: 800 333 5722
information@3e-co.com

Electro Enterprises
Phone: 405 427 6591
sales@electroenterprises.com

Eoff Electric
Phone: 877 371 3633
mike.lindner@eoff.com

GE Supply Co
Phone: 800 243 7313
sales@gesupply.com

Gopher Electronics
Phone: 800 592 9519
info@gopherelectronics.com

Great Lakes Automation Supply
Phone: 269 963 6282
glebcweb@kendallgroup.com

HD Campbell
Phone: 46 8 730 50 00
sales@hdcampbell.com

H Poll Electric Co
Phone: 419 255 1660
jsnyder@hpoll.com

Hagemeyer North America
Phone: 717 843 0786
info@hagemeyerna.com

Hammond Electronics / EMSCO
Phone: 800 929 2677
webmaster@hammondelec.com

Hannan Supply Co
Phone: 270 442 5456
Fax: 270 442 5456

Hughes-Peters Inc
Phone: 800 590 4055
sales@hughespeters.com

JRH Electronics Inc

Phone: 856 988 8696
info@jrhelec.com

Kom Lamb
Phone: 877 566 5262
sales@komlamb.com

Lakeland Engineering Equipment Co
Phone: 800 328 5613
sales@lakelandengineering.com

Master Distributors
Phone: 888 473 5297
kurt@masterdistributors.com

Minarik Automation
Phone: 888 646 2745
info@minarikcorp.com

Newark Inone
Phone: 800 263 9275
quote@newarkinone.com

Peerless Electronics
Phone: 800 285 2121
nysales@peerlesselectronics.com

Powell Electronics
Phone: 800 235 7880
info@powell.com

Power Signal
Phone: 216 378 6176
cgintert@powersignal.com

Rainco of Dallas
Phone: 800 779 0502
raincosales@raincoofdallas.com

Ram Meter Inc
Phone: 800 446 4035
sales@rammeter.com

RS Electronics
Phone: 800 555 5312
rselectronics@rselectronics.com

Sager Electronics
Phone: 800 724 3780
sagerinfo@sager.com

Satair USA
Phone: 404 675 6300
info@satair.com

Selecta Products Inc
Phone: 800 722 6445
melajak@selectaproductsinc.com

Simcona Electronics Corp
Phone: 800 274 6266
info@simcona.com

Standard Electric Supply Co
Phone: 800 597 3726
inside.sales@sescow.com

State Electronics
Phone: 973 887 2550
honeywell@state-elec.com

Steiner Electric Co
Phone: 847 228 0400
info@steinerelectric.com

Steven Engineering
Phone: 800 258 9200
salesinfo@steveneng.com

Stuart Electric Supply
Phone: 801 466 8603
sesslc@qwest.net

Tanyx Measurements
Phone: 800 370 0110
sales@tanyx.com

Williams Supply Co
Phone: 800 533 6969
joehobson@williams-supply.com

THAILAND

Honeywell
Phone: 662 693 3099
Fax: 662 693 3089

INTERNET

(1) Authorized Repair Centers
(2) Authorized Repair and Distribution Centers
<http://www.honeywell.com/sensing/info.sc@honeywell.com>

SALES AND SERVICE

Honeywell serves its customers through a world-wide network of sales offices and distributors. For application assistance, current specifications, pricing or the name of the nearest distributor, contact a nearby sales office or call number on the back page.

WARRANTY AND REMEDY

Honeywell warrants goods of its manufacture as being free of defective materials and faulty workmanship. Honeywell's standard product warranty applies unless agreed to otherwise by Honeywell in writing; please refer to your order acknowledgement or consult your local sales office for specific warranty details. If warranted goods are returned to Honeywell during the period of coverage, Honeywell will repair or replace, at its option, without charge those items it finds defective. The foregoing is the Buyer's sole remedy and is in lieu of all other warranties, expressed or implied, including those of merchantability and fitness for a particular purpose.

In no event shall Honeywell be liable for consequential, special, or indirect damages.

While we provide application assistance personally, through our literature and the Honeywell Website, it is up to the customer to determine the suitability of the product in the application.

Specifications may change without notice. The information we supply is believed to be accurate and reliable as of this printing. However, we assume no responsibility for its use.

Automation and Control Solutions

Honeywell
21 Chemin du Vieux Chêne
38240 Meylan Cedex
Tel: (33) 4 76 41 72 00
www.honeywell.com

The Honeywell logo is displayed in a bold, red, sans-serif font.