

WIRING DIAGRAMS

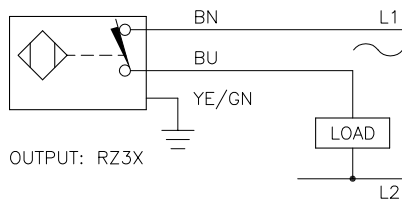

WARNING: NO SHORT-CIRCUIT PROTECTION
ALWAYS WIRE A LOAD IN SERIES WITH THE SENSOR.

LOCKNUT LN-M30

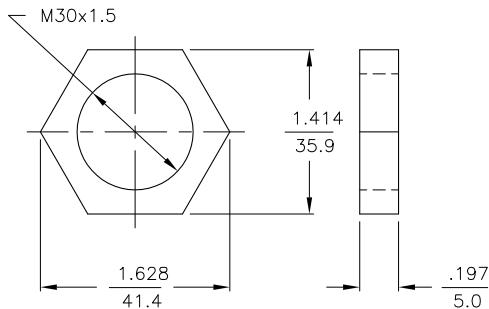

SPECIFICATIONS

| | |
|---------------------------------------|---|
| OPERATING VOLTAGE | 20-250 V AC |
| LINE FREQUENCY | 40-60 Hz |
| DIFFERENTIAL TRAVEL (HYSTERESIS) | 3-15% (5% TYPICAL) |
| VOLTAGE DROP ACROSS CONDUCTING SENSOR | ≤ 7.0 V at 500 mA |
| OUTPUT FUNCTION -RZ | NORMALLY CLOSED 2-WIRE AC SELF-CONTAINED |
| SHORT-CIRCUIT PROTECTED | NO |
| CONTINUOUS LOAD CURRENT | ≤ 500 mA |
| OFF-STATE (LEAKAGE) CURRENT | ≤ 1.7 mA |
| MINIMUM LOAD CURRENT | ≥ 5.0 mA |
| INRUSH CURRENT | ≤ 8.0 A (≤ 10 ms/5 Hz) |
| TIME DELAY BEFORE AVAILABILITY | ≤ 25 ms |
| POWER-ON EFFECT PROTECTION | INCORPORATED |
| PROTECTION AGAINST TRANSIENTS | 5 kV, 10 ms, 10 kΩ |
| OPERATING TEMPERATURE | -25°C to +70°C (-13°F to +158°F) |
| ENCLOSURE | MEETS NEMA 1, 3, 4, 6, 13 AND IEC IP67 |
| SHOCK | 30 g, 11 ms |
| VIBRATION | 55 Hz, 1 mm AMPLITUDE (IN ALL 3 PLANES) |
| LED FUNCTION | RED: OUTPUT ENERGIZED |
| SENSING RANGE | 15 mm = .591" (NOMINAL) |
| SWITCHING FREQUENCY | 20 Hz |
| REPEATABILITY | ≤ 2% of RATED OPERATING DISTANCE |
| EMBEDDABLE (SHIELDED) | NO |

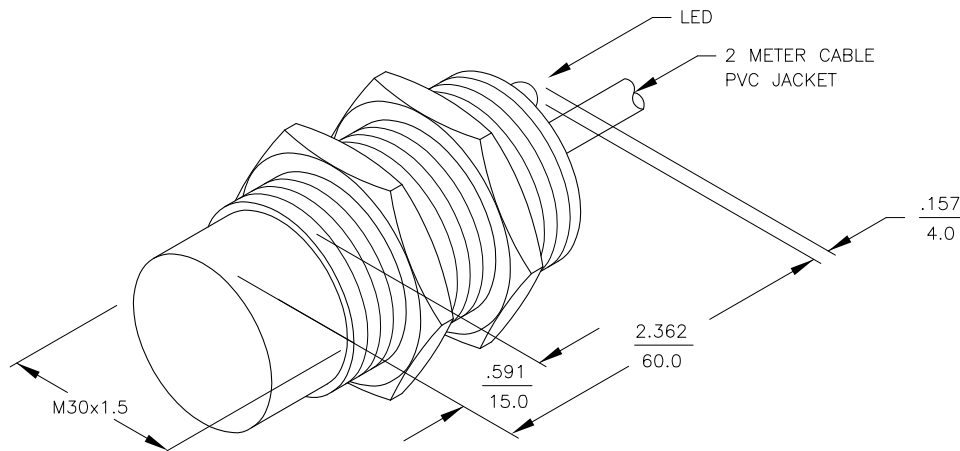

| | | | | | |
|---|------------------------------------|---|-----------------------|---|--|
| RELATED DOCUMENTS 1. 2. 3. 4. | 3RD ANGLE PROJECTION | THIS DRAWING IS PROPERTY OF TURCK INC. USE OF THIS DOCUMENT WITHOUT WRITTEN PERMISSION IS PROHIBITED. | | 3000 CAMPUS DRIVE MINNEAPOLIS, MN 55441 1-800-544-7769 (763) 553-7300 (763) 553-0708 fax turck.com | |
| | MATERIAL BRASS BARREL | ALL DIMENSIONS DISPLAYED ON THIS DRAWING ARE FOR REFERENCE ONLY | DRFT GMB DATE 9/29/88 | DESCRIPTION Ni15-G30-RZ3X | |
| FINISH COPPER/NICKEL/ CHROME PLATING | CONTACT TURCK FOR MORE INFORMATION | | DSGN SCALE NONE | IDENTIFICATION NO. T1316000 | |
| UNIT OF MEASUREMENT INCH [MILLIMETER] | | DO NOT SCALE THIS DRAWING | | FILE: T1316000 | |

| | | | | |
|-----|-------------------------------|-----|----------|---------|
| B | UPDATE TO CURRENT TITLE BLOCK | RDS | 12/16/02 | 5504 |
| REV | DESCRIPTION | BY | DATE | ECO NO. |