

Isolating Switching Amplifier MS13-12Ex0-R 1-channel

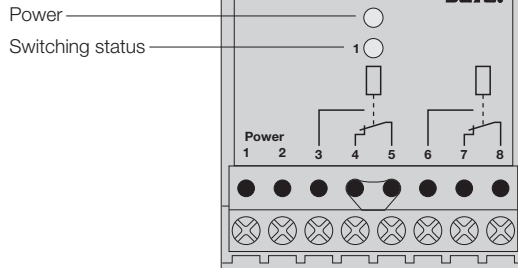

1



- **1-channel isolating switching amplifier**
- **Intrinsically safe input circuit EEx ia**
- **Area of application according to ATEX: II (1) GD, I (M1)**
- **Galvanic isolation between input circuit, output circuit and supply voltage**
- **Input circuit monitoring for short-circuit and wire-break (can be disabled)**
- **2 relay outputs, each with one SPDT contact**
- **Selectable common alarm output**
- **Selectable NO/NC output function**
- **Universal supply voltage (20...250 VAC/20...125 VDC)**

The MS13-12Ex0-R switching amplifier is a single channel device with an intrinsically safe input circuit. It can be connected to sensors according to EN 60947-5-6 (NAMUR), variable resistors or potential-free contacts. The output circuit has two independent relays, each one with an SPDT contact.

The output is programmable for normally open mode (NO/A) or normally closed mode (NC/R). Select NO mode by installing a jumper between terminals 11 and 12. Leave terminals 11 and 12 open for NC mode.

This unit provides optional wire-break and short-circuit monitoring of the input circuit. The input circuit monitoring function is disabled by jumpering terminals 13/14.

Linking terminals 15 and 16 changes the function of one relay (terminals 8, 7, 6) to provide a common output fault alarm (II).

The green LED on the front cover indicates that the devices are powered.

During an input fault, the alarm output is disabled (relay de-energised, green LED off). When no faults are in any of the input circuits and the power is on, the alarm output is enabled (relay energised, green LED on). The yellow LEDs indicate the switching status of the outputs.

When using mechanical contacts as the input device, the input circuit monitoring function must be disabled (IV), or shunt resistors (II) connected to the contacts. This will prevent the switching amplifier from recognising the contacts as a wire-break or a fault.

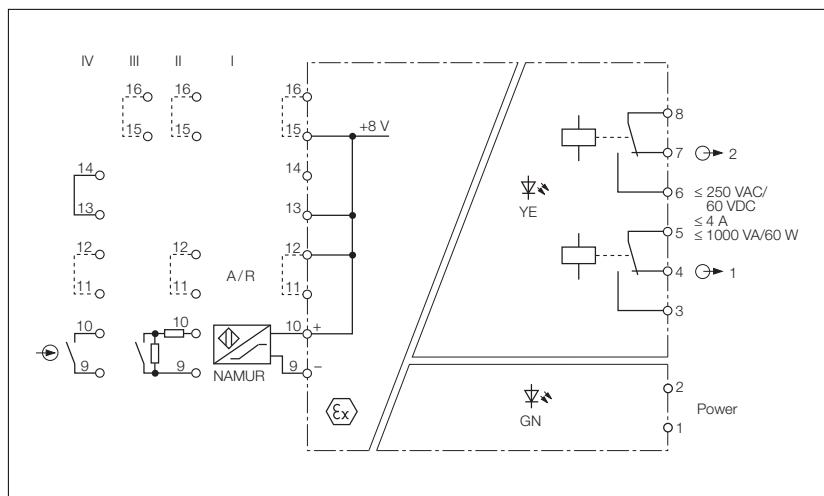

Isolating Switching Amplifier MS13-12Ex0-R

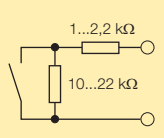
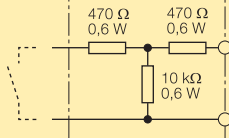
Type	MS13-12Ex0-R
Ident-no.	5321302
Supply voltage U_B	20...250 VAC/20...125 VDC
Line frequency (AC)	40...70 Hz
Power consumption	≤ 3 W
Galvanic isolation	between input circuit, output circuit and supply voltage for 250 V _{rms} test voltage 2.5 kV _{rms}
Input circuits	according to EN 60947-5-6 (NAMUR), intrinsically safe according to EN 50020
Operating characteristics	
- Voltage	8 V
- Current	8 mA
Switching threshold	1.55 mA
Hysteresis	0.2 mA
Wire-break threshold	≤ 0.1 mA
Short-circuit threshold	R _s approx. 200 Ω
Contact configuration	
Of mechanical switches with active input circuit monitoring function	  <p>resistor module WM1, ident-no. 0912101</p>
Output circuits	2 relay outputs
Contacts	1 SPDT contact, silver-alloy + 3 μ m Au
Switching voltage	≤ 250 VAC/60 VDC
Switching current	≤ 4 A
Switching capacity	≤ 1000 VA/60 W
Switching frequency	≤ 10 Hz
Ex-approval acc. to certificate of conformity	DMT 01 ATEX E 119
Maximum nominal values	
- No load voltage U_0	11.0 V
- Short-circuit current I_0	55 mA
- Power P_0	150 mW
- Safety voltage U_m	250 VAC/125VDC
Max. external inductances/capacitances L_0/C_0	
- [EEx ia] IIC	1 mH/500 nF
- [EEx ia] IIB	3 mH/2500 nF
- [EEx ia] I	10 mH/10 μ F
Marking of device	Ⓔ II (1) GD [EEx ia] IIC I (M1) [EEx ia] I
LED Indications	
- Power	green
- Switching status	yellow
Housing	50 mm wide, Polycarbonate/ABS
Mounting	panel mounting or snap-on clamps for top-hat rail (DIN 50022)
Connection	2 x 8 self-lifting pressure plates
Connection profile	$\leq 2 \times 2.5$ mm ² or 2×1.5 mm ² with wire sleeves
Degree of protection (IEC 60529/EN 60529)	IP20
Operating temperature	-25...+60 °C

