

3-Wire DC

Ripple.	≤10%
Differential Travel (Hysteresis).	3-15% (5% typical)
Voltage Drop Across Conducting Sensor.	≤1.8 V
	- Si...K08/K10(AP71, AN7) . ≤0.7 V
	- Bi/Ni../S34 ≤1.8 V
	- Bi 2-Q8SE-AP/AN.. . . . ≤2.5 V
Trigger Current for Overload Protection	≥220 mA on 200 mA Load Current
	≥170 mA on 150 mA Load Current
	≥120 mA on 100 mA Load Current
Off-State (Leakage) Current	<100 µA
No-Load Current	<10 mA (Uprox ≤15 mA)
Time Delay Before Availability	≤8 ms
Power-On Effect	Per IEC 947-5-2
Reverse Polarity Protection	Incorporated
Wire-Break Protection	Incorporated
Transient Protection.	Per EN 60947-5-2
Shock.	30 g, 11 ms
Vibration	55 Hz, 1 mm Amplitude in all 3 Planes
Repeatability	≤2% of Rated Operating Distance
	Bi 2-Q8SE-AP/AN.. ≤5% of Rated Operating Distance

4-Wire DC

Ripple.	≤10%
Differential Travel (Hysteresis).	3-15% (5% typical)
Voltage Drop Across Conducting Sensor.	≤1.8 V at 200 mA
Trigger Current for Overload Protection	≥220 mA on 200 mA Load Current
	≥170 mA on 150 mA Load Current
	≥120 mA on 100 mA Load Current
Off-State (Leakage) Current	<100 µA
No-Load Current	<10 mA (Uprox ≤15 mA)
Power-On Effect	Per IEC 947-5-2
Reverse Polarity Protection	Incorporated
Wire-Break Protection	Incorporated
Transient Protection.	Per EN 60947-5-2
Shock.	30 g, 11 ms
Vibration	55 Hz, 1 mm Amplitude in all 3 Planes
Repeatability	≤2% of Rated Operating Distance

WIRING DIAGRAMS

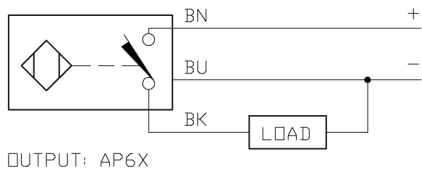

SHORT-CIRCUIT AND OVERLOAD PROTECTED

LOCKNUT LN-M12

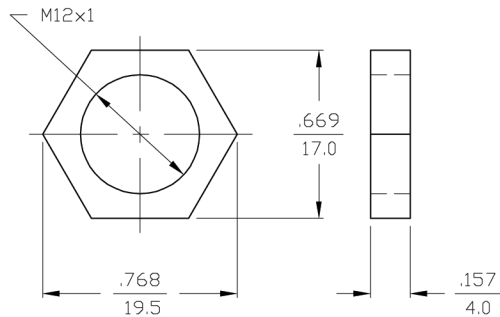

SPECIFICATIONS

OPERATING VOLTAGE	10-30 VDC
RIPPLE	≤10%
HYSTERESIS (DIFFERENTIAL TRAVEL)	3-15% (5% TYPICAL)
VOLTAGE DROP ACROSS CONDUCTING SENSOR	≤1.8 V at 200 mA
OUTPUT FUNCTION	NORMALLY OPEN 3-WIRE DC SELF-CONTAINED
TTL COMPATIBLE	NO
SHORT-CIRCUIT PROTECTED	YES
TRIGGER CURRENT FOR OVERLOAD PROTECTION	≥220 mA
CONTINUOUS LOAD CURRENT	≤200 mA
OFF-STATE (LEAKAGE) CURRENT	<10 μA
NO-LOAD CURRENT	5.5-9.5 mA
TIME DELAY BEFORE AVAILABILITY	≤8 ms
POWER-ON EFFECT PROTECTION	INCORPORATED
REVERSE POLARITY PROTECTION	INCORPORATED
WIRE-BREAK PROTECTION	INCORPORATED
PROTECTION AGAINST TRANSIENTS	2 kV, 1 ms, 1 kΩ
OPERATING TEMPERATURE	-25°C to +70°C (-13°F to +158°F)
ENCLOSURE	MEETS NEMA 1, 3, 4, 6, 13 AND IEC IP67
SHOCK	30 g, 11 ms
VIBRATION	55 Hz, 1 mm AMPLITUDE (IN ALL 3 PLANES)
LED FUNCTION	RED: OUTPUT ENERGIZED
SENSING RANGE	2 mm = .079" (NOMINAL)
SWITCHING FREQUENCY	2000 Hz
REPEATABILITY	≤2% of RATED OPERATING DISTANCE
EMBEDDABLE (SHIELDED)	YES

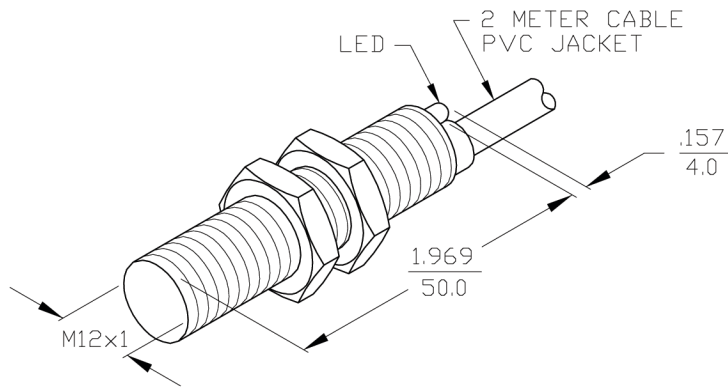

MATERIAL BRASS BARREL		3RD ANGLE PROJECTION		TURCK INC
FINISH COPPER/NICKEL/ CHROME PLATING				
DRWN GMB	DATE 2/6/91	PART NO. Bi2-G12-AP6X 50MM		
CHKD	DATE	SIZE B		ID NO. 4635400
TMI		DIMENSIONS ARE IN INCHES mm		REV
REVISIONS		SCALE NONE	BMPC-D\4635400	SHEET OF

REV	DESCRIPTION	DRFT	DATE	CHKD