

Installation Instructions

Series 4000 LED Universal Control Bases, Open and Closed Types

IMPORTANT: SAVE THESE INSTRUCTIONS FOR FUTURE USE.

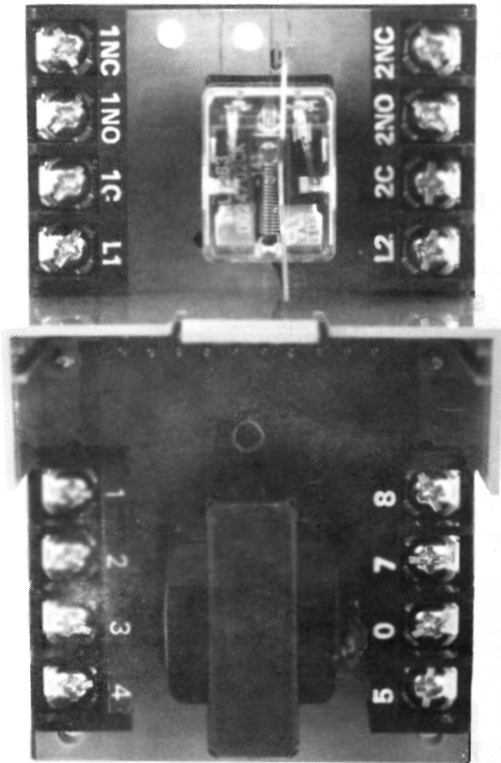

Features

- Universal control base takes all Series 4000 LED plug-in control function modules
- Compact design-requires minimum panel space
- All molded parts of rugged, impact resistant Noryl
- Heavy-duty, easy-to-wire terminal connections with industrial spacings
- Positive guidance for insertion of plug-in control function module
- Positive locking of plug-in module after insertion
- Gold plated, spring loaded connectors between control base and plug-in module ensures circuit continuity and reliability
- Plug-In, heavy duty DPDT output relay with positive lock-in feature. Solid state outputs available as accessories

Specifications

Ambient temperature [F (C)]	-40°...135° (-40°...57°)
Power supply	Models 60-1600B and 60-1610B: 102...132V, 50/60 Hz Models 60-1601B and 60-1611B: 200...264V, 50/60 Hz
Power consumption	2 VA
Output relay Standard, supplied with control base	Plug-in with heavy-duty DPDT contact: 5 A at 120V AC, non-inductive 2.5 A at 240V AC, non-inductive
Solid state output accessories Order separately	#8-651 1 A, 120V AC, Triac output #8-652 30 mA, 120V AC/DC, F.E.T. output #63-116 Voltage signal logic output #63-115 Open collector logic output

Description

The Series 4000 LED universal control base combined with any Series 4000 LED plug-in control function module achieves a new dimension in compact, versatile and dependable photoelectric controls.

This forward-looking modular design concept simplifies pre-engineering for preparing wiring diagrams, panel and field wiring, and production downtime for field changes when function requirements are changed.

The universal control base, nominally 3 in. wide by 5 in. high (76 x 127 mm), is the power supply for the LED light source, the plug-in control function module and the output relay. It is molded of rugged high-impact-strength Noryl.

All external connections are made to a heavy duty, barriered, easy-to-wire, molded Noryl terminal board with industrial spacings between terminals. Note that the high voltage and low voltage connections are isolated from each other. The terminals are #8-32 nickel plated, solid brass, pressure type with non-rotating clamps on the screws, which will accept up to two #12 AWG (19 strand, 3/64 in. insulation) wires or crimp-type lug connectors.

It includes a guide for the plug-in control function module to assure proper module insertion, positive alignment and mating of the control connectors. The connectors between module and base are both gold plated and spring loaded to insure circuit continuity and reliability. The Plug-In Module is positively and automatically latched into the module holders after insertion. Unlatching for inspection or removal can be performed without the use of tools.

The standard output device is a heavy duty, plug-in DPDT industrial type relay, conservatively rated at 5 amps, 120V AC and 2.5 amps at 230V AC (non-inductive). Solid state plug-in relay, logic and open collector adapters are available as accessories. A hold-down clip on the control base over the output device assures reliable operation in high vibration industrial environments.

The Series 4000 LED universal control base is available as chassis only (open type) or enclosed in a general purpose NEMA 1 enclosure with knockouts on top, bottom and sides. Special environmental NEMA 3, 4, 5, 12, and 13 and hazardous location NEMA 7 and 9 enclosures are available as special enclosures.

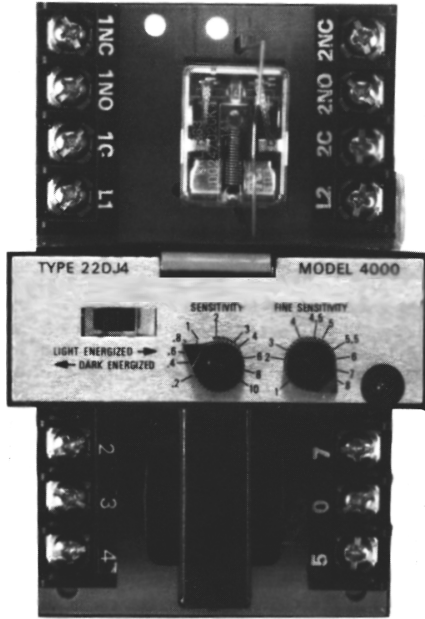

Easy insertion or removal of Series 4000 plug-in control module

Series 4000 LED plug-in control function modules

For complete control function, description, application and wiring diagram information, refer to the plug-in control function bulletins as listed below.

Function	Plug-in module	Bulletin
On-Off		
General purpose	Type 22DJ3	PA-7421
High sensitivity	Type 22DJ4	
Time delay		
On, Off or On + Off delay	Type 22DJ9	PA-7431

Ordering instruction

Model	Description
60-1600B	Control base 120V AC, 50/60 Hz with plug-in relay. Open type.
60-1610B	Model 60-1600 in NEMA 1 general purpose enclosure.
60-1601B	Control base 230V AC, 50/60 Hz with plug-in relay. Open type.
60-1611B	Model 60-1601 in NEMA 1 general purpose enclosure.
To order NEMA 7 and 9 explosion-proof enclosure, specify open type base and 61-4635 enclosure.	

Installation

The Series 4000 universal control base can be mounted in any position on a wall, partition, panel, frame, bracket or similar support. While the enclosure is being mounted, the control base (and plug-in module) should be stored in a safe place to avoid moisture and mechanical damage.

The enclosure mounting hole dimensions are shown below. Sheet metal, wood, or machine screws, bolts, or similar fasteners may be used. When the enclosure has been securely mounted, connect conduits or cables to the enclosure using the knockout holes provided. Then remount the control base (and plug-in control module).

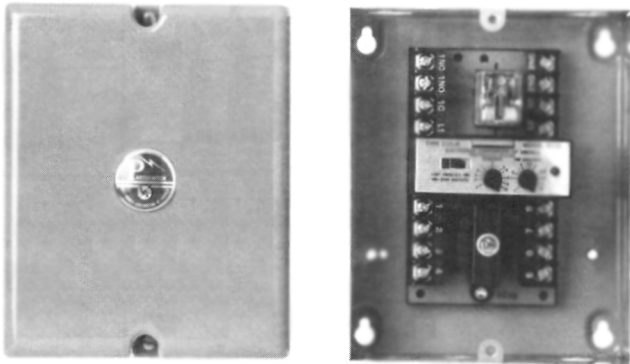

Series 4000 universal control base in NEMA 1 enclosure

Outline and mounting dimensions

Unless otherwise indicated, dimensions shown are in inches. Those in parentheses are in millimeters.

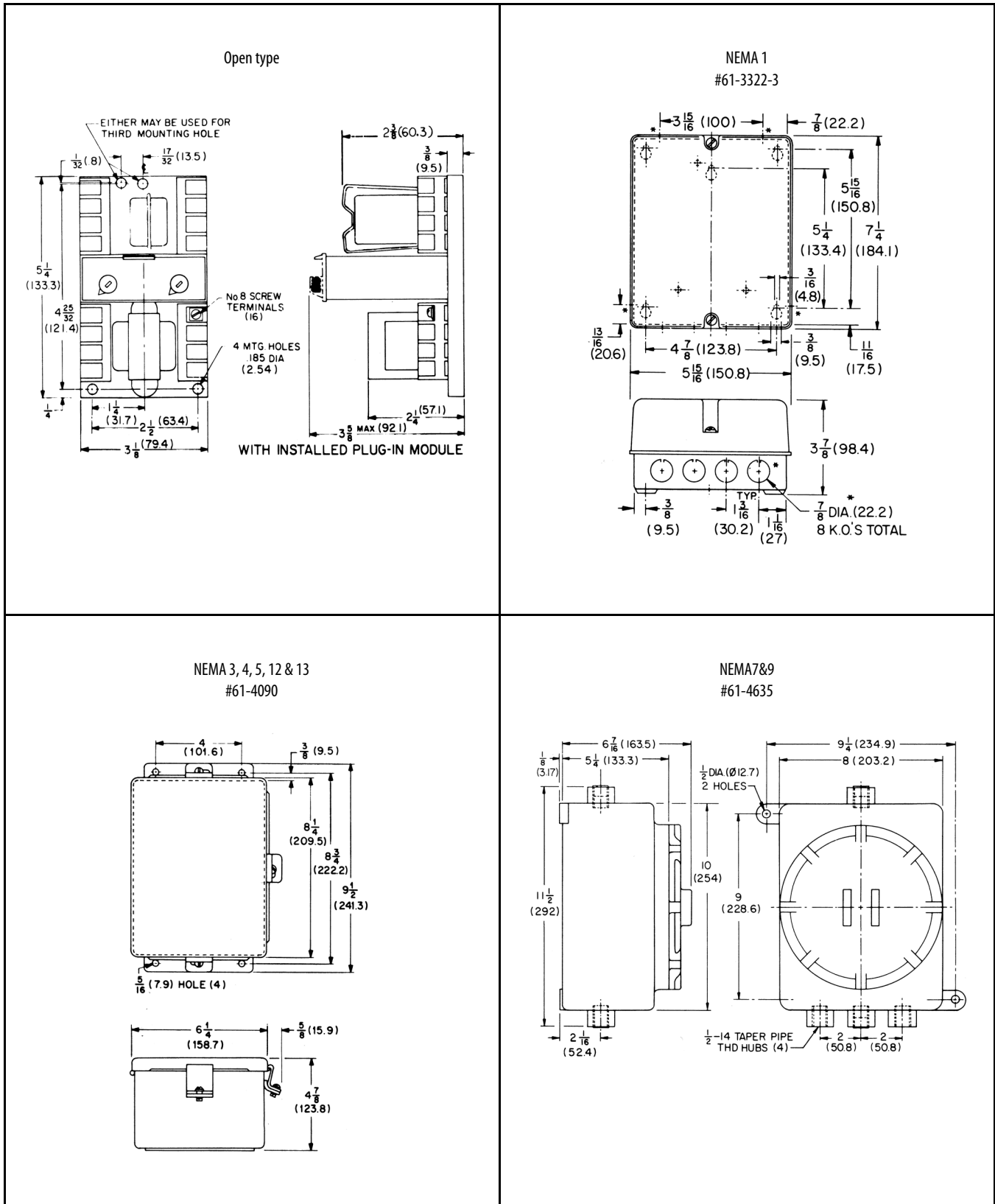

Series 4000 control base wiring

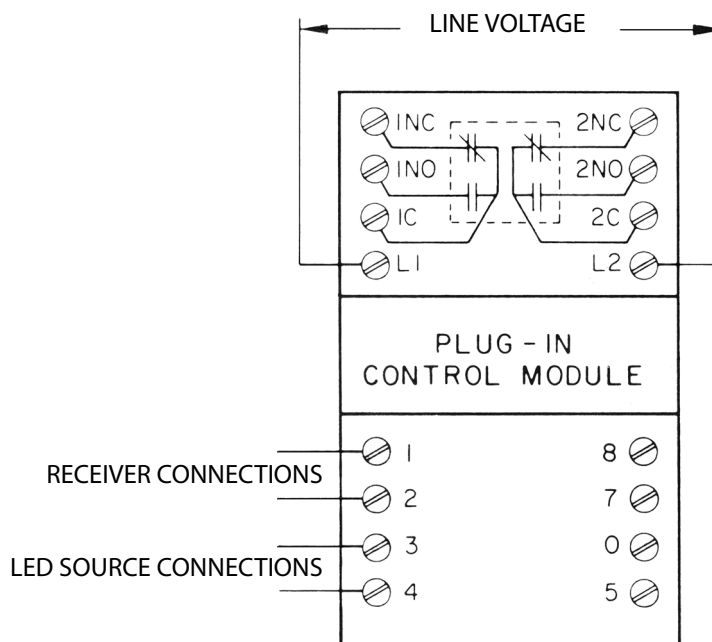

For complete wiring information, refer to proper control module bulletin.

Wiring

The basic wiring diagram for the Series 4000 control base is shown on page 4 of this bulletin. However, the control circuit wiring connections will depend on the plug-in control function and light source/receiver combination (or scanner) used. These application wiring connections are described in detail in the appropriate plug-in control function module bulletins: See page 2 of this bulletin for proper reference.

All external wiring should conform to the provisions of the National Electric Code and applicable local codes. Rigid or flexible conduit may be used for interconnection of units, but rigid conduit for maximum electrical shielding is recommended for any extensions of the photoelectric receiver cable.

All photoswitch control circuits are filtered to reduce the effect of transients, but since all electronic circuits are to some degree transient susceptible, care should be taken to avoid unnecessary coupling of transients into the circuit. The most efficient method of wiring the Series 4000 control is to bring the line voltage and output leads in from the top and the low voltage leads from the bottom.

IMPORTANT

The photodetector wiring should never be run in the same conduit as the power wiring.

Warranty

We guarantee for one year from date of shipment to replace or, at our option, to repair any products or parts thereof (except lamps, electronic tubes and photocells) which are found defective in material or workmanship or which otherwise fail to conform to the contract description or to any warranty, expressed or implied.

We make no warranties which extend beyond the description of our product on the face of our sales orders.

The Purchaser's remedies with respect to any product or part sold by us shall be limited exclusively to the right to replacement or repair as above provided. In no event shall we be liable for consequential or special damages of any nature which may arise in connection with such product or part.

www.rockwellautomation.com

Power, Control and Information Solutions Headquarters

Americas: Rockwell Automation, 1201 South Second Street, Milwaukee, WI 53204-2496 USA, Tel: (1) 414.382.2000, Fax: (1) 414.382.4444

Europe/Middle East/Africa: Rockwell Automation NV, Pegasus Park, De Kleetlaan 12a, 1831 Diegem, Belgium, Tel: (32) 2 663 0600, Fax: (32) 2 663 0640

Asia Pacific: Rockwell Automation, Level 14, Core F, Cyberport 3, 100 Cyberport Road, Hong Kong, Tel: (852) 2887 4788, Fax: (852) 2508 1846