

PL μ S[®] PS-5000 Series Programmable Limit Switch

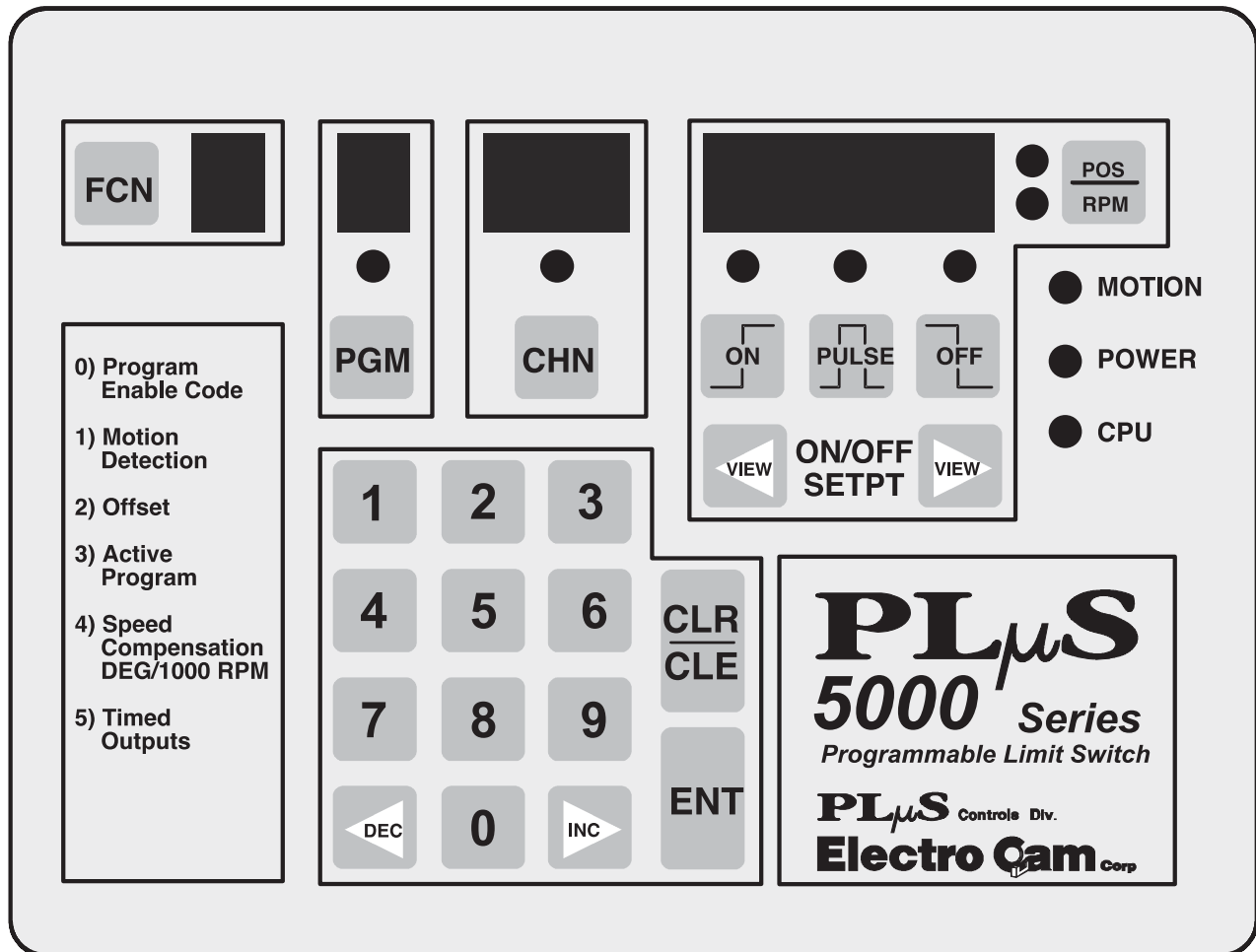

Programming & Installation Manual

January 2006

Electro Cam Corp.

13647 Metric Rd • Roscoe, IL 61073 USA • 815/389-2620 • FAX 815/389-3304 • 800-228-5487 (U.S.A. and Canada)

**Copyright © 2001
All Rights Reserved**

Neither this document nor any part may be reproduced or transmitted in any form or by any means without permission in writing from the publisher.

Electro Cam[®], **PL μ S**[®], **SLIMLINE**[®], and **PL μ SNET**[®] are all registered trademarks of **Electro Cam**^{Corp.}

PS-5000 Quick Start Guide

These five basic programming settings are required for operation of the Electro Cam Corp. PS-5000 controller

1) Scale Factor

The default value is 360 increments per revolution. To increase or decrease this number press FCN key, the “0” key, then ENT. Press CHN key until SF is displayed above CHN key. Enter new scale factor and press ENT. Press POS/RPM key to exit this function.

2) Direction of Increasing Rotation

Turn the resolver or encoder, making sure controller position increases. If not, change the direction of rotation. Press FCN key, the “0” key, then ENT. Press CHN key until “dr” is displayed above CHN key. Press PULSE key to toggle between CL (clockwise) and CCL (counterclockwise). Press POS/RPM key to exit this function.

3) Setting Displayed Position to Match Actual Machine Position “FCN2: OFFSET”

With your machine set at zero or a known position, make sure the displayed controller position is correct. If not, press FCN key, the “2” key, then ENT. Enter the current machine position and press ENT key. Press POS/RPM key to exit this function.

4) Setting On/Off Setpoints for Each Output

Press the CHN key, then select the channel you wish to program by pressing the number keys. Press ENT key. Press ON key, enter the position at which you want the output to turn on, then press ENT key. Press OFF key, enter the position at which you want the output to turn off, then press ENT key. Press POS/RPM key to exit this function.

Note: Repeat step 4 until you have entered all the setpoints in the channels you wish to program. You can enter multiple on/off setpoints in a channel, but they cannot overlap.

5) To View or Check On/Off Setpoints Entered for an Output

Press CHN key, then select the output you wish to view by pressing the number keys. Press ENT key. Press the right VIEW key; the on setpoint will be displayed and the LED above the ON key will be on. Press VIEW key again; the off setpoint will be displayed and the LED above the OFF key will be on. If you have multiple setpoints in the same channel, keep pressing the VIEW key and the display will cycle through the other on/off setpoints. Press POS/RPM key to exit this function.

You are now ready to run the controller with your outputs turning on and off at the specified positions. If you wish to apply additional conditions to enable your outputs, such as speed compensation, timed outputs, or motion detection, refer to the appropriate section of this manual for details. Depending on your model, it may be possible to enable your outputs based on an input from another device.

Table of Contents

Section—Introduction

Basic Cam Switch Operation	1-1
Standard Features	1-1
Optional Features	1-2
Model Summary	1-3

Section 2—Dimensions & Component Locations

Controllers with External I/O Module Rack 5001, 5101, 5004, 5104, 5034, 5134	2-1
Controllers with I/O Modules on Controller Back 5021, 5121, 5024, 5124	2-2
Controllers with Built-In Transistor I/O Chips 5011, 5111	2-3

Section 3—Wiring

Logic Terminal Strip Wiring	3-1
External I/O Racks (5001, 5101, 5004, 5104)	
16 Module I/O Rack—Standard	3-2
16 Module I/O Rack—Analog	3-2
16 Module I/O Rack—M16 Slimline	3-2
24 & 48 I/O Rack	3-3
I/O Modules on Controller (5021, 5121, 5024, 5124)	3-4
Module Wiring, Outputs	3-4
Sinking/Sourcing Defined	3-5
Module Wiring, Inputs	3-5
Input Wiring, 3-Wire Sensors	3-5
Built-In Transistor I/O Chips (5011, 5111)	
Description	3-6
Output Wiring, Sourcing	3-7
Output Wiring, Sinking	3-8
Output Wiring to PLC	3-9
PS-5X34 Controller & 32 DC Output Rack	3-10
PS-5X34 Output Rack Layout	3-11
PS-5X34 Wiring to PLC's	3-12
PS-5X34 Output Rack Transistor Array Chips	3-13
Resolver Wiring	3-14
Cable for Stainless Steel Resolver	3-15
Encoder Cable Installation	3-16

Section 4—Programming, Standard Features

Access Levels	4-1
Keyboard Description	4-2
Output Setpoint Programming	4-3
Master Level Programming	
FCN 0 Programming Enable	4-4
dr Direction of Rotation	4-4
SF Scale Factor	4-4
P1 & P2 Keyboard Enable	4-4
tb Time Base for Output Timing	4-5
Enhanced Position/RPM Display Logic	4-5
dd Display Default	4-5
tr Toggle RPM	4-5
rU rPM Display Update Frequency	4-6
ct, cS, cA Communications Parameters	4-6
FCN 6 Output Channel Access	4-7
FCN 7 Motion ANDing	4-8
FCN 8 Subdividing Outputs	4-9
FCN 9 Enable Inputs and Modes	4-9

Setup Level Programming	
FCN 1 Motion Setpoints	4-10
FCN 2 Offset	4-10
FCN 3 Program Number	4-10
FCN 4 Speed Compensation, Standard	4-12
Speed Compensation, Negative	4-12
FCN 5 Timed Outputs	4-13

Section 5—Programming, Optional Features

Leading Trailing Speed Comp (“-L”)	
FCN 0 Speed Comp Type	5-1
FCN 4 Leading/Trailing Speed Comp	5-1
Analog Output (“-A”)	
FCN 1 Analog Offset & High RPM	5-2
Outputs Based on Direction of Rotation (“-D”)	
Direction ANDing	5-2
Direction Hysteresis	5-2
Gray Code Output (“-G”)	
Gray Code Conversion Ladder	5-3
FCN 4 Gray Code Speed Comp	5-3
Extra Program Storage (“-F”)	
Pulses/Programs Available	5-4
Program Number Displays	5-4
FCN 3 Program Number Changes	5-5
Viewing/Editing Program	5-6
Phase Mark Registration (“-P”)	
Examples and Adjustment Methods	5-7
Input Information	5-8
CHN 80 Auto-Center Registration	5-9
CHN 81 Adjust Registration Center	5-9
Reversal of Centering Logic	5-10
“OFF” Logic Examples	5-10

Appendix

Output Grouping & Modes	
Introduction	A-1
Configuration Examples	A-2
Mode 0	A-3
Mode 1	A-4
Mode 2	A-6
Mode 3	A-8
Mode 4	A-10
Error Messages	A-12
Communication Port Wiring	A-14
Encoder Position vs. Degrees	A-15
60 Pulse Disc—Position vs. Degrees	A-15
Alternate Functions	A-16
Alt Fcn 1 Transducer Position	
Alt Fcn 2 Logic Input Status	
Alt Fcn 3 Offset Value	
Alt Fcn 4 60 Pulse Disc	
Alt Fcn 1002 Keyboard Test	
Alt Fcn 1003 LED Display Test	
Alt Fcn 1004 Watchdog Timer Test	
Alt Fcn 1005 Control Model Info	
Alt Fcn 1006 Options & Rev. #	
Alt Fcn 7000 Restore Defaults	
Alt Fcn 7001 Clear Setpoints	
Alt Fcn 7999 EEPROM Test	
Remote Display Installation	A-17
Specifications	A-18

Index

WARRANTY

1. Electro Cam Corp. warrants that for a period of twelve (12) months from the date of shipment to the original purchaser, its new product to be free from defects in material and workmanship and that the product conforms to applicable drawings and specifications approved by the Manufacturer. This warranty period will be extended on Distributor or OEM orders to a maximum of eighteen months to take into consideration Distributor or OEM shelf time.
 2. The remedy obligations of Electro Cam Corp. under this warranty are exclusive and are limited to the repair, or at its option, the replacement or refund of the original purchase price of any new apparatus which proves defective or not in conformity with the drawings and specifications. Shipment of the claimed defective product to Electro Cam Corp. shall be at the cost of the consumer. Shipment of the repaired or replacement product to the consumer shall be at the cost of Electro Cam Corp. All claims must be made in writing to Electro Cam Corp., 13647 Metric Road, Roscoe, IL 61073 USA.
 3. In no event, and under no circumstances, shall Electro Cam Corp. be liable for:
 - a. Any product damaged or lost in shipment. Inspection for damage should be made before acceptance or signing any delivery documents releasing responsibility of the delivering carrier.
 - b. Product failure or damages due to misuse abuse, improper installation or abnormal conditions of temperature, dirt or other contaminants as determined at the sole discretion of Electro Cam Corp.
 - c. Product failures due to operation, intentional or otherwise, above rated capacities as determined at the sole discretion of Electro Cam Corp.
 - d. Non-authorized expenses for removal, inspection, transportation, repair or rework. Nor shall the manufacturer ever be liable for consequential and incidental damages, or in any amount greater than the purchase price of the equipment.
 4. There are no warranties which extend beyond the description on the face hereof. This warranty is in LIEU OF ALL OTHER WARRANTIES, EXPRESSED OR IMPLIED INCLUDING (BUT NOT LIMITED TO) ANY IMPLIED WARRANTIES OF MERCHANTABILITY OR FITNESS FOR A PARTICULAR PURPOSE, ALL OF WHICH ARE EXPRESSLY DISCLAIMED. Any legal proceeding arising out of the sale or use of this apparatus must be commenced within (18) months of the date of shipment from the manufacturer.
-

Introduction

Basic Cam Switch Operation

A PL μ S control's main purpose is to operate outputs in a manner that simulates cam switches. The drawing to the right illustrates the operation of a cam switch. Its function is to switch the load on and off at the same rotary positions of the cam shaft during each revolution of that cam shaft. The rotating cam shaft is driven by a machine at a 1:1 ratio, so that the on / off positions of the cam cycle always match specific positions in the machine cycle. However, cam limit switches have the following disadvantages: unreliable (wear), hard to adjust (machine must be stopped during adjustment), and they cannot run at high speeds because of contact bounce and excessive mechanical wear.

PL μ S controls overcome these basic cam switch problems. They have no moving wear parts, they are easy to adjust from the keyboard with the machine running or stopped, and they can operate at speeds up to 3000 RPM. They also add many capabilities far beyond simple cam switch logic.

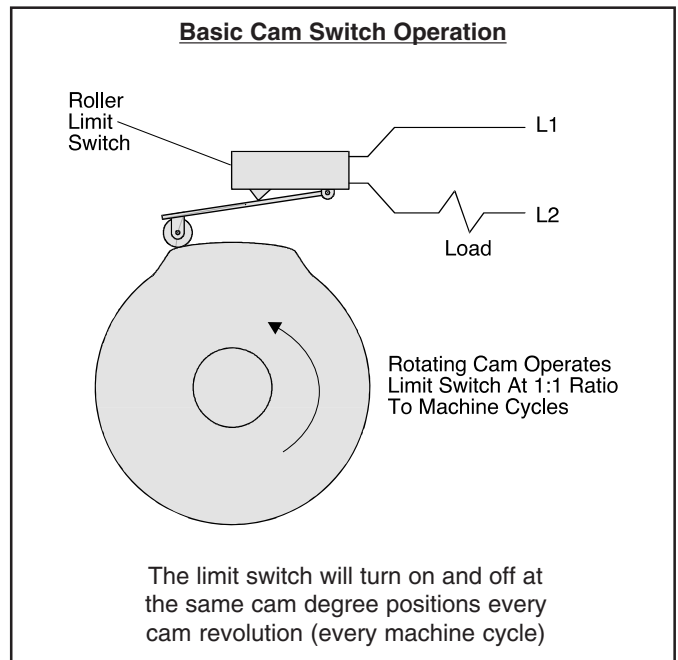

Standard Product Features

Keyboard/Controller

The keyboard controller is the main component of the PL μ S system. The front keypad and displays provide a complete user interface from which every aspect of the control's operation can be monitored and programmed. When properly mounted with the gasket provided, the keyboard meets NEMA 4 standards. A clear silicon rubber boot assembly is available to provide NEMA 4X protection for installations where harsh washdown chemicals are used.

Ease of Setup

All output position setpoint values are simply entered through the numeric keypad. These setpoints can be adjusted while the machine is running or stopped by using the increment, decrement, or numeric keys. The keyboard is also used to synchronize the control's position to the machine, eliminating the need to mechanically adjust the resolver's shaft position.

Multiple Programs

Depending on the model ordered, up to 64 different programs, or "recipes" can be stored in the control's memory. This minimizes down time for job change over because simply changing program numbers makes all of the output setting changes required. Program numbers can be changed by mechanical switches; PLC's (using the hardware program select inputs); the keypad; or serial communication messages.

Output Speed Compensation

Speed compensation allows outputs to compensate for the response time of the controlled devices by turning on earlier as machine speeds increase. This eliminates the need to adjust output settings whenever machine speeds are changed. Using speed compensation often allows higher production speeds and eliminates the need for output adjustments.

Motion ANDing

A speed range can be programmed into the controller, and outputs can then be ANDed with the speed range so that they will be disabled unless the machine speed is within the range. This can be used to turn off outputs if the machine stops; disable outputs until the machine reaches a minimum speed; or disable outputs if the machine goes above a specified maximum speed. A common use for this feature is disabling outputs to glue valves so the flow of glue turns off if the machine stops.

Timed Outputs

Outputs can be programmed to turn on at the programmed "on" position and turn off when the specified time elapses, rather than staying on until an "off" position is reached. The result is a constant output duration, regardless of machine speed. The output will turn off when the "off" position is reached if it hasn't already timed out. Timed outputs are used to drive devices which require a fixed time to perform a task, regardless of machine speed.

Standard Product Features (continued)

Selectable Scale Factor (resolvers only)

The number of increments per revolution (Scale Factor) is programmed by the user. Standard controls have a maximum of 1024 increments per revolution and "-H" option (high resolution) controls have a maximum of 4096 increments per revolution. To make the control operate and program in degrees, a Scale Factor of 360 is used. In some applications it is desirable to use a Scale Factor that defines each increment as a specific distance in engineering units (ex: 1 inc = .1" of travel).

Output Grouping and Modes of Operation

Outputs can be subdivided into groups and each group can be associated with an input device. There are five different modes of operation that can be selected for each group. For example, some modes allow the group to activate only when the corresponding input has signaled that product is present. Glue control is a typical place where outputs are disabled until product is sensed as being present. For details, see page A-1.

Serial Communication

Serial communication provides an RS-232 and an RS-485 communication port. Using PL μ SNET software for IBM compatible computers, available from Electro Cam Corp., the control's entire program can be saved from the control to a disk file or loaded from a disk file to the control. The program can be printed or edited using the computer. It is also possible to send individual communication commands to the control, while running, to change settings in the program. The user must write appropriate software to communicate at the individual command level.

Expanded Operator Access

This feature gives the operator access to motion detection settings, offset, active program number, and speed compensation.

NOTE: Serial Communication and Expanded Operator Access were "-C" and "-E" options prior to date code 9740.

Optional Product Features

Analog Output, "-A"

Units with this option can output an analog signal that is linearly proportional to RPM. The analog signal level at zero RPM can be programmed through the keyboard, as well as the RPM that corresponds to maximum signal. No measuring equipment is required for initial setup, and calibration is not needed. Typical uses are control of glue pressure as machine speed changes, and speed matching of other equipment to the machine being controlled.

Outputs Based On Rotation Direction, "-D"

In standard PL μ S controllers, outputs will turn ON/OFF based on resolver position, regardless of which way the resolver is turning. With the "-D" option, outputs can be based on resolver rotation direction.

Large Program Memory, "-F"

Depending on the number of outputs ordered, standard controls can store up to 64 programs consisting of not more than 1258 output pulses total. Controls with the "-F" option increase this capacity by storing up to 256 programs consisting of not more than 4589 output pulses total.

Gray Code Position Output, "-G"

The "-G" option provides eight bits of position information on the last eight outputs. This "gray code" output can be connected to a PLC or other electronic control device, eliminating the need for expensive accessory cards. The PLC can then make control decisions that do not demand a fast response, while other PL μ S outputs directly control devices that must operate quickly and consistently.

High Resolution, "-H" (resolvers only)

Controls with this option can divide the resolver shaft

rotation into as many as 4096 increments. Standard controls have a maximum of 1024 increments.

Leading/Trailing Edge Speed Comp, "-L"

This option allows the "on" and "off" edges of output pulses to be speed compensated by different amounts. High speed gluing is a common application where the "on" and "off" edges of the output signal have to be compensated by different amounts.

Phase Mark Registration, "-P"

Phase mark registration allows the PL μ S control to determine if a product appears before or after a programmed timing window. If mis-registration occurs, the product's timing can be adjusted manually, or by a PLC or similar controller interfaced to the PL μ S control.

Caustic Washdown Boot, "-W"

The face of the keyboard is rated NEMA 4X (meets NEMA 1, 4, 4X, and 12). For additional protection against caustic washdown, grease, oil, dirt, and normal wear, a clear silicone rubber boot is available that fits over and around the keyboard. The back of the boot provides a good seal between the back of the keyboard and the control panel. The boot is transparent and pliable, allowing the keyboard to be viewed and operated through it. Controls ordered with the "-W" option are shipped with the boot fitted over the keyboard. Boots may also be ordered separately and installed in the field (#PS-4904-99-001).

Remote Display

A remote display which connects to the RS-485 port is available for units ordered with both the "-C" and "-E" options. This allows position and RPM information to be displayed up to 1000 feet away from the controller.

PS-5000 Series Model Summary



PS-5001
PS-5101
PS-5004
PS-5104
PS-5034
PS-5134

These Models Use External I/O Module Racks

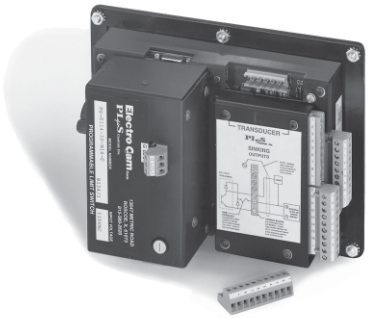

PS-5011
PS-5111

These Models Use Built-In I/O Transistor Chips

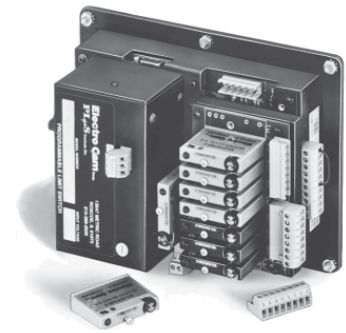

PS-5021
PS-5121
PS-5024
PS-5124

These Models Have I/O Modules On Controller Back

Key To Option Selection

20-240 VAC: Change "-10-" to "-20-".
24-24 VDC: Change "-10-" to "-24-".

- A** Analog output proportional to speed
- F** Additional setpoint/program storage
- G** Gray code position output
- H** High resolution, resolver only
- L** Individual leading/trailing edge speed compensation
- P** Register mark phasing
- U** CE mark - requires 24VDC input
- V** Vibration protective coating
- W** Washdown Boot

Model	Output Type	Transducer	# of Outputs	# of Programs	Output Modes?	Options
PS-5001-10-016	Module Rack	Encoder	16	64	no	A, F, G, L, P, V, W, 20, 24
PS-5101-10-016	Module Rack	Resolver	16	64	no	A, F, G, H, L, P, V, W, 20, 24
PS-5001-10-024	Module Rack	Encoder	24	48	no	F, G, L, V, W, 20, 24
PS-5101-10-024	Module Rack	Resolver	24	48	no	F, G, H, L, V, W, 20, 24
PS-5001-10-048	Module Rack	Encoder	48	24	no	F, G, L, V, W, 20, 24
PS-5101-10-048	Module Rack	Resolver	48	24	no	F, G, H, L, V, W, 20, 24
PS-5004-10-016	Module Rack	Encoder	16	64	yes	A, F, G, L, P, V, W, 20, 24
PS-5104-10-016	Module Rack	Resolver	16	64	yes	A, F, G, H, L, P, V, W, 20, 24
PS-5004-10-024	Module Rack	Encoder	24	48	yes	F, G, L, V, W, 20, 24
PS-5104-10-024	Module Rack	Resolver	24	48	yes	F, G, H, L, V, W, 20, 24
PS-5004-10-048	Module Rack	Encoder	48	24	yes	F, G, L, V, W, 20, 24
PS-5104-10-048	Module Rack	Resolver	48	24	yes	F, G, H, L, V, W, 20, 24
PS-5011-10-N08	Transistor, Sinking	Encoder	8	64	no	F, L, V, W, 20, 24
PS-5111-10-N08	Transistor, Sinking	Resolver	8	64	no	F, H, L, V, W, 20, 24
PS-5011-10-N16	Transistor, Sinking	Encoder	16	64	no	F, G, L, P, V, W, 20, 24
PS-5111-10-N16	Transistor, Sinking	Resolver	16	64	no	F, G, H, L, P, V, W, 20, 24
PS-5011-10-P08	Transistor, Sourcing	Encoder	8	64	no	F, L, V, W, 20, 24
PS-5111-10-P08	Transistor, Sourcing	Resolver	8	64	no	F, H, L, V, W, 20, 24
PS-5011-10-P16	Transistor, Sourcing	Encoder	16	64	no	F, G, L, P, V, W, 20, 24
PS-5111-10-P16	Transistor, Sourcing	Resolver	16	64	no	F, G, H, L, P, V, W, 20, 24
PS-5034-10-032	Transistor, Ext. Rack	Encoder	32	32	yes	F, G, L, V, W, 20, 24
PS-5134-10-032	Transistor, Ext. Rack	Resolver	32	32	yes	F, G, H, L, U, V, W, 24
PS-5034-10-064	Transistor, Ext. Rack	Encoder	64	16	yes	F, G, L, V, W, 20, 24
PS-5134-10-064	Transistor, Ext. Rack	Resolver	64	16	yes	F, G, H, L, U, V, W, 24
PS-5021-10-M09	Modules on Back	Encoder	9	64	no	A, F, L, V, W, 20, 24
PS-5121-10-M09	Modules on Back	Resolver	9	64	no	A, F, H, L, P, U, V, W, 20, 24
PS-5024-10-M09	Modules on Back	Encoder	9	64	yes	A, F, L, V, W, 20, 24
PS-5124-10-M09	Modules on Back	Resolver	9	64	yes	A, F, H, L, P, U, V, W, 20, 24

Controllers w/ External I/O Module Rack

- PS-5001
- PS-5101
- PS-5004
- PS-5104
- PS-5034
- PS-5134

Detailed View of 24 VDC Version

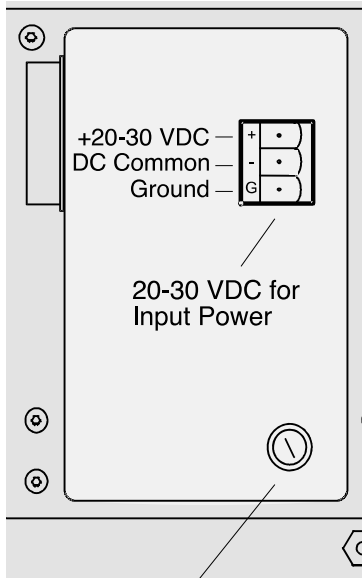

1-1/4 Amp Fuse:
Part# PS-9000-4114
(Bussman MDL 1-1/4)
Slow-Blow Type Fuse

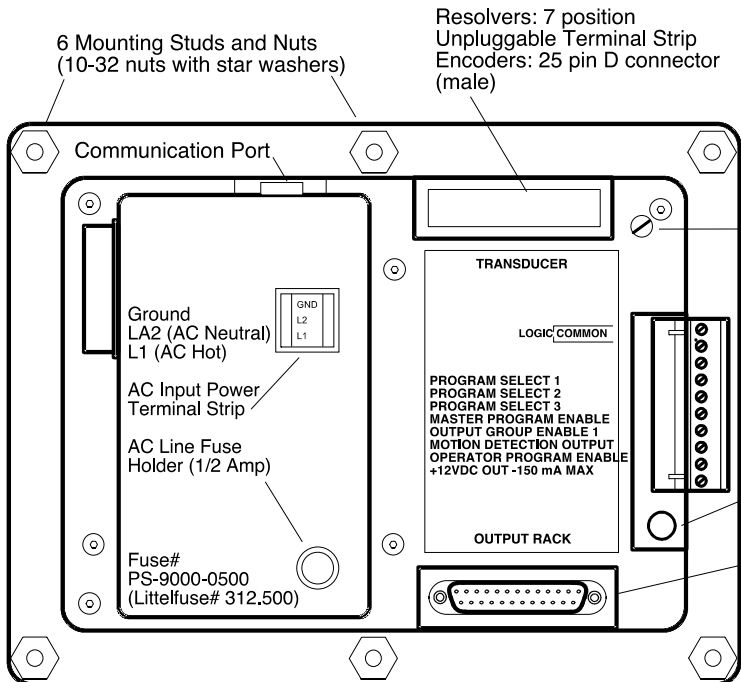

- Grounding Screw for Cable Shields
- Unpluggable Terminal Strip for Logic Inputs (located beneath output terminal strips)
- 1/4 Amp fuse for +12VDC

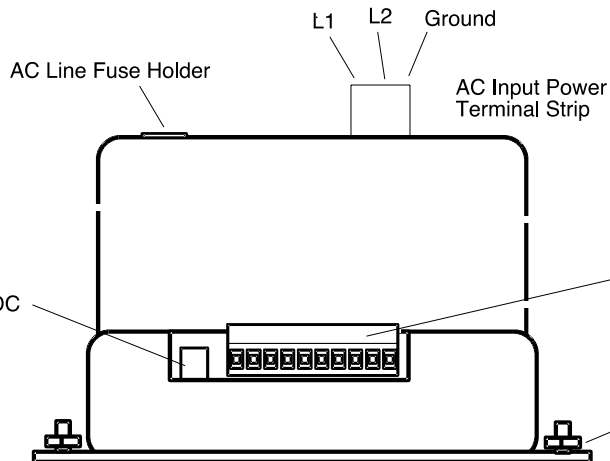

1/4 Amp Fuse for +12VDC
PS-9005-025
(Wickman# 1937-035)

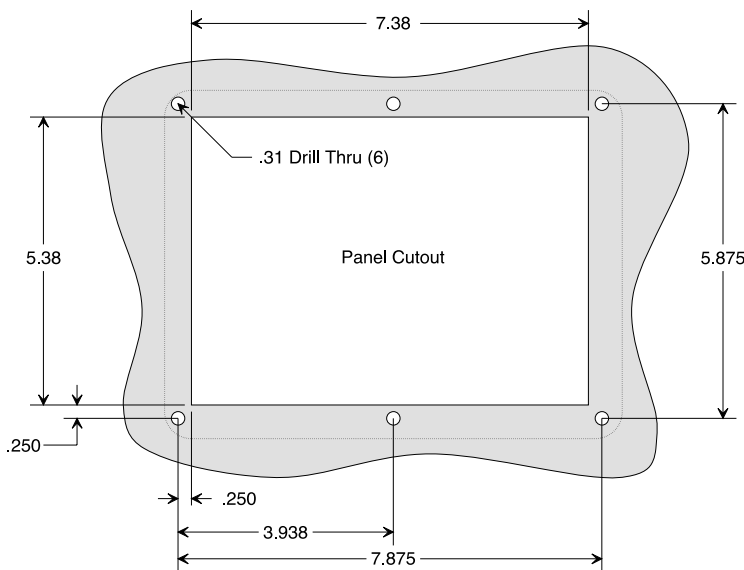

See Page 2-4 for Controller Dimensions

Controllers w/ I/O Modules on Controller Back

PS-5021
PS-5121
PS-5024
PS-5124

Detailed View of 24 VDC Version

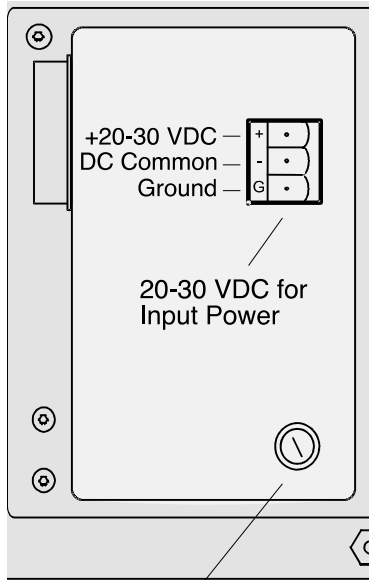

1-1/4 Amp Fuse:
Part# PS-9000-4114
(Bussman MDL 1-1/4)
Slow-Blow Type Fuse

See Page 2-4
for Controller
Dimensions

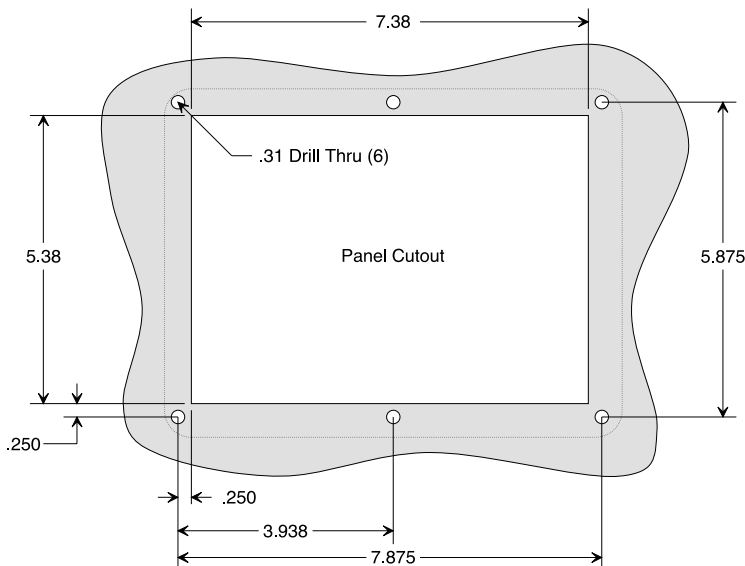
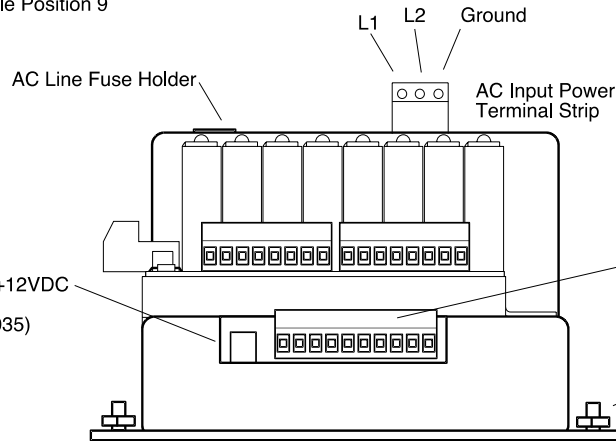
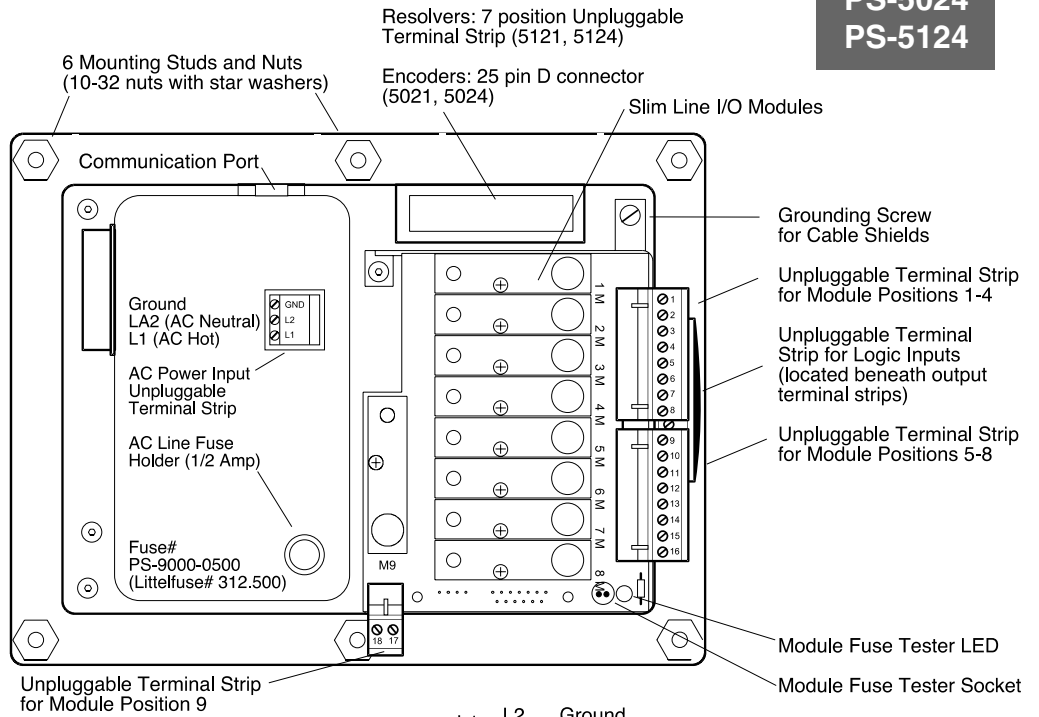

Slimline Modules

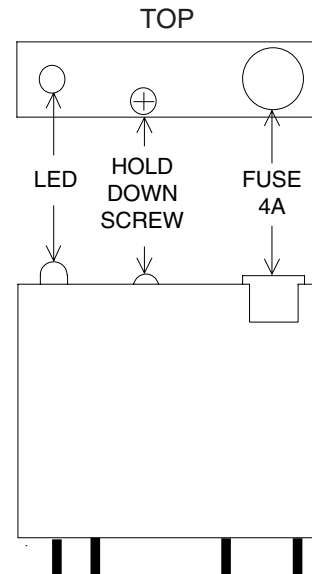

Controllers with Built-In Transistor I/O Chips

PS-5011
PS-5111

Detailed View of 24 VDC Version

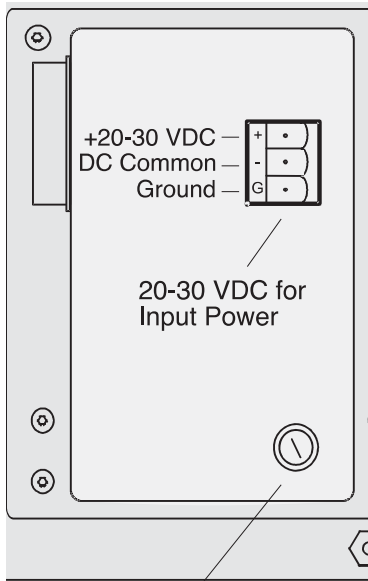

1-1/4 Amp Fuse:
Part# PS-9000-4114
(Bussman MDL 1-1/4)
Slow-Blow Type Fuse

1/4 Amp Fuse for +12VDC
PS-9005-025
(Wickman# 1937-035)

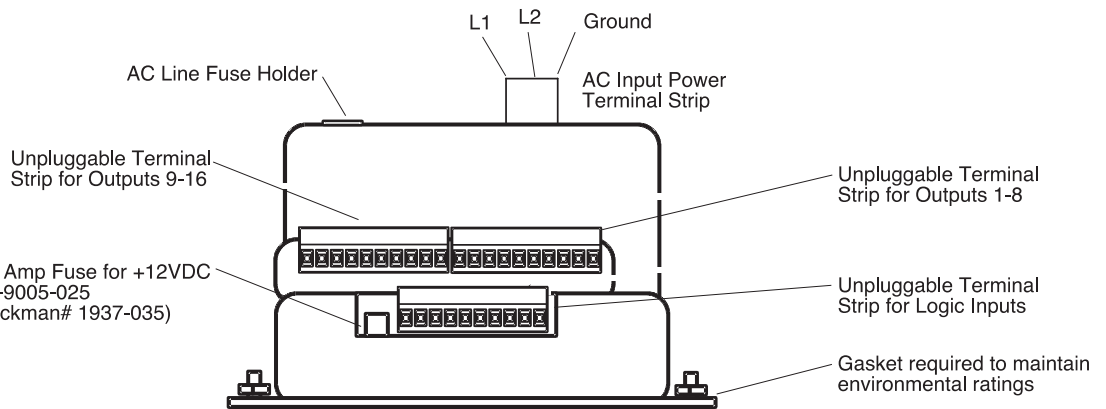
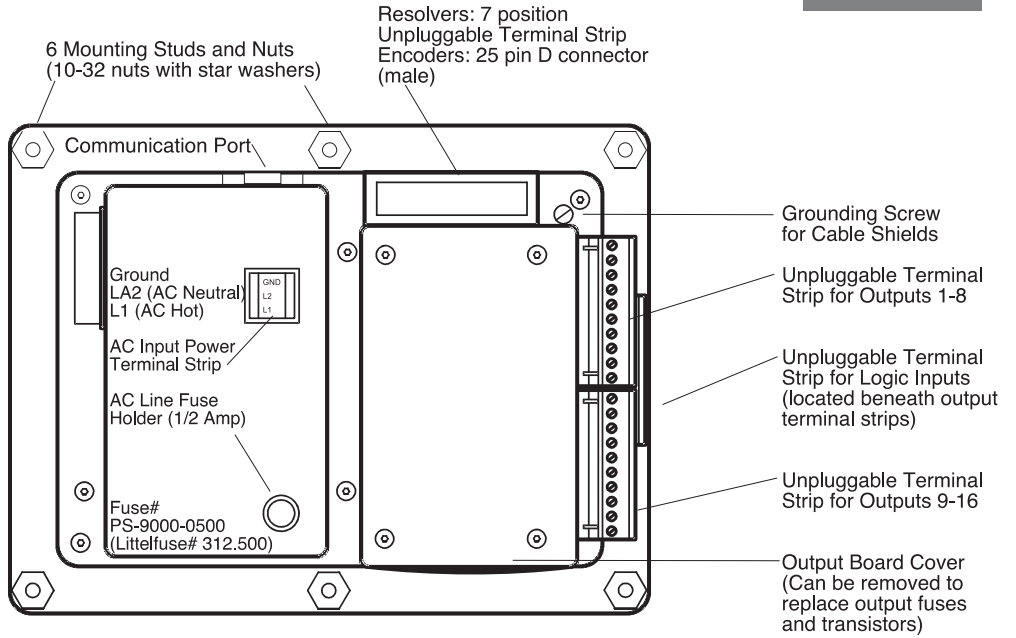

See page 2-5
for Controller
Dimensions

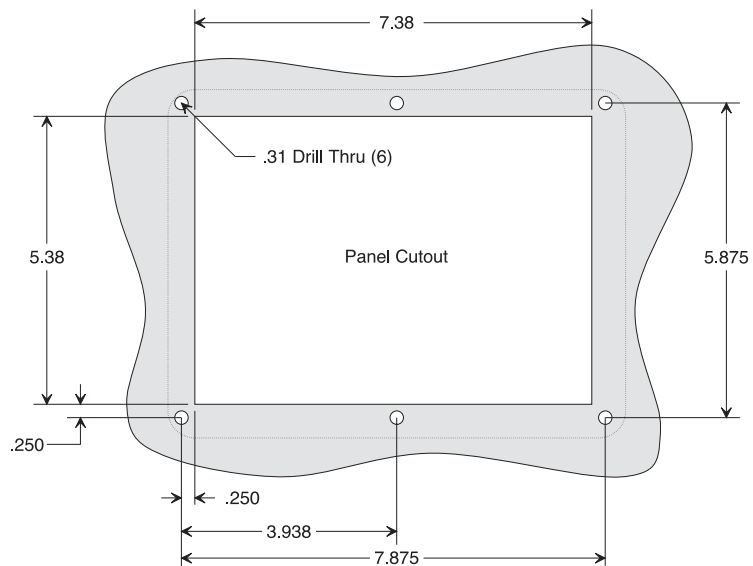

2-3 Dimensions & Component Locations

Controller Dimensions

- PS-5001
- PS-5101
- PS-5004
- PS-5104
- PS-5034
- PS-5134

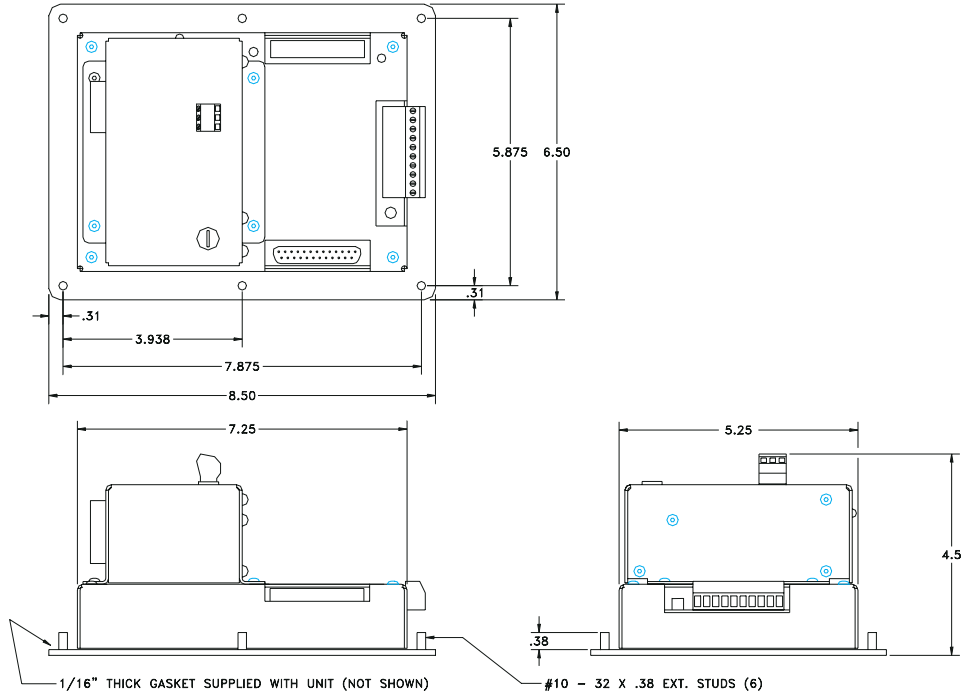

- PS-5021
- PS-5121
- PS-5024
- PS-5124

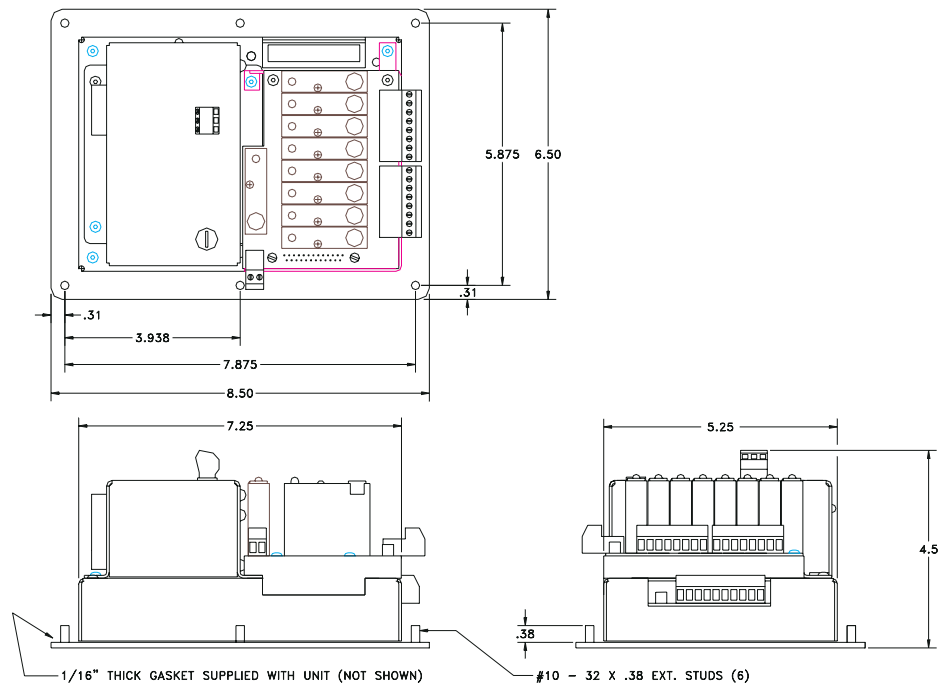

Controller Dimensions

PS-5011
PS-5111

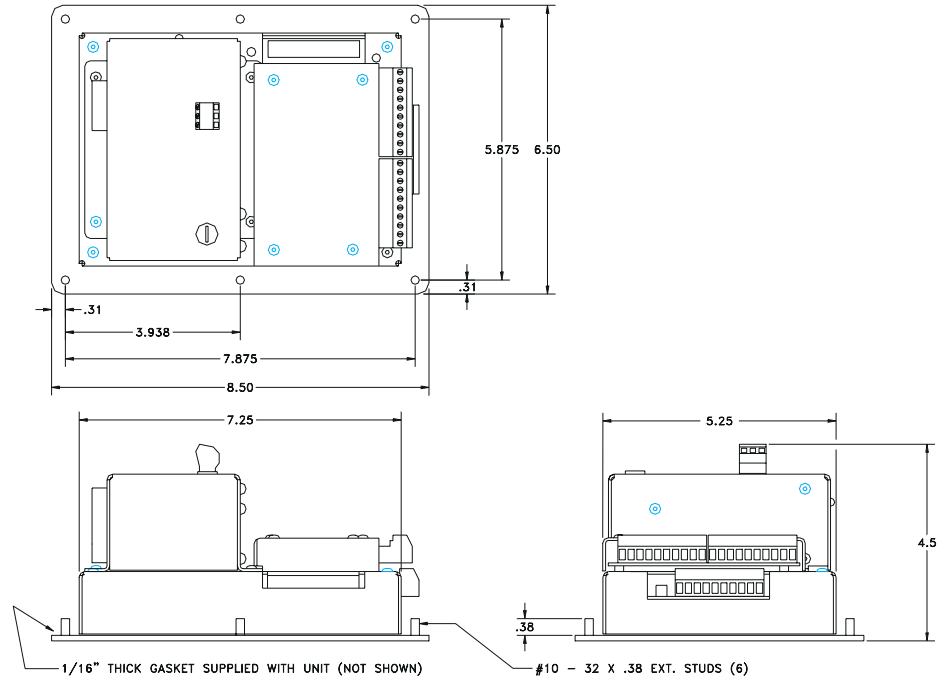

Logic Terminal Strip Wiring—Standard Controller

Logic Terminal Strip

(see pp. 2-1 thru 2-3 for location)

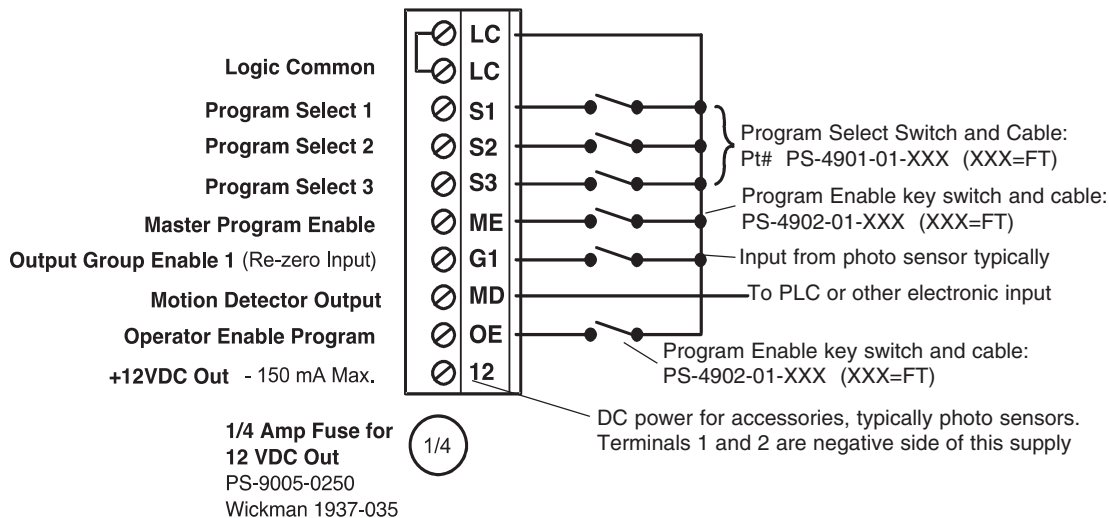

General Logic Input Information

The logic inputs, Terminals 2-7 & 9, are switched by a current sinking path to Logic Common. They can be switched by mechanical switches, relays, or NPN transistor outputs. Logic input terminal voltage is approximately 12 VDC, and 4 mA of current are conducted through the switch to Logic Common.

Program Select Inputs (Terminals 3, 4, and 5)

These inputs determine which program in the current program bank is controlling the outputs. When any of these inputs are connected to Logic Common, they take priority over the keyboard selected active program (FCN 3). If these inputs are being used, make sure that the FCN 3 active program is set to 1. Input combinations are:

PRG #	1	2	3	4	5	6	7	8
SEL 1	off	on	on	off	off	on	on	off
SEL 2	off	off	on	on	on	on	off	off
SEL 3	off	off	off	off	on	on	on	on

Master Program Enable (Terminal 6)

When the Master Program Enable input is switched to Logic Common, all programming operations are accessible. A key switch is commonly used for this input to prevent unauthorized personnel from accessing the more complicated features of the control. A temporary jumper can also be installed for initial programming at the master level, and then removed when this programming is completed.

Output Group 1 Enable (Re-Zero Input) (Terminal 7)

On standard 5XX1 controls, switching this input to Logic Common instantly changes the control's position to zero degrees. The position re-zeroes off of the leading edge of the signal, but is not held at zero while the input is energized. When the controller is de-energized, the controller position will revert to the offset value programmed in FCN 2.

On models PS-5004, 5104, 5024, and 5124 this input is the enable input for output Group 1. There are four programmable modes of operation available for enable inputs. For more information see the Output Grouping and Enable Modes section in the Appendix.

Motion Detection Output (Terminal 8)

This is a sourcing output signal that is on whenever the current machine speed is within or equal to the Low and High RPM setpoints (FCN 1, page 4-7). The circuit is basically a 12 VDC supply being sourced through a 470 ohm resistor. It is typically connected to PLC inputs or external solid state output modules. Because the 5000 Series controls have Motion ANDing, any of the standard outputs can be programmed to be on whenever the motion logic is on. This is an alternative to the Motion Output when it is not compatible with an input circuit or if a higher voltage or current needs to be controlled.

Operator Program Enable (Terminal 9)

When this terminal is switched to Logic Common, access to programming at the Operator level is enabled. A key switch can be used to control who can make program changes at the Operator level. Operator access can also be enabled through a keyboard enable code number.

12 VDC Power Output (Terminal 10)

The 12 VDC accessory power supply is regulated and capable of supplying up to 150 mA. It is protected by a 1/4 amp fuse which is located just below the Logic Terminal strip. This supply is intended to be used for electronic sensors or other electronic circuitry. It should not be used to power relays or any other inductive devices. Logic Common (terminals 1 or 2) is the negative side of this 12 VDC supply.

External 16 Module I/O Racks: Dimensions & Specifications

Standard 16 Rack: PS-4100-11-216

PS-5001
PS-5101
PS-5004
PS-5104

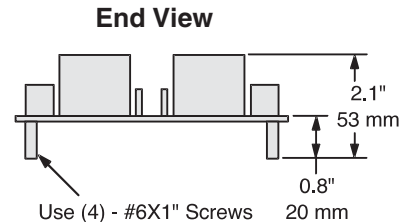
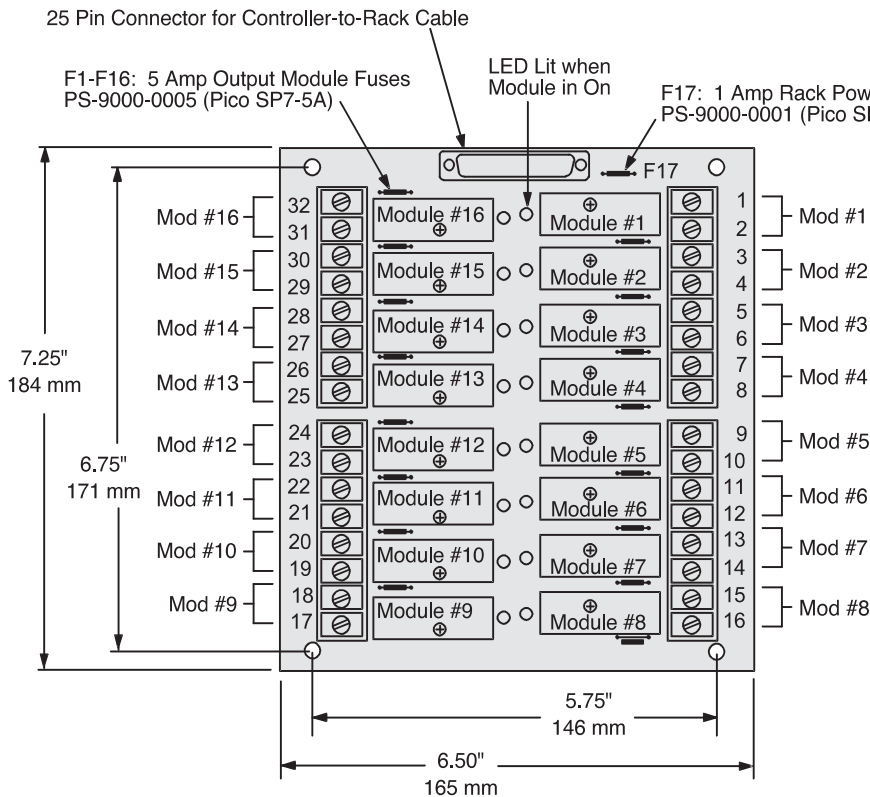

Notes:

- A **Standard** module is required for each Input or Output used. See Appendix for module specs.
- AC and DC modules can be mixed as needed.
- Input modules can be used only with 5004 and 5104 units.
- Output modules act like switches; they do not supply power to loads.
- Position 16 of Analog racks is dedicated to analog output and will not work with other modules. If an analog module is used, it must be installed in position 16.
- **Odd Terminals:** (+) or hot
Even Terminals: (-) or load

Slimline M16 Rack

DIN Rail Rack: PS-4100-11-M16-D

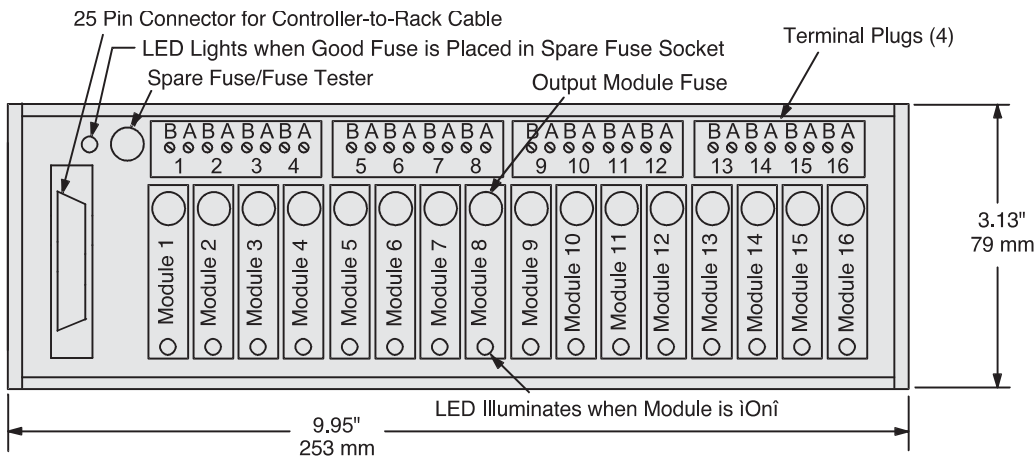

End View

DIN Rail (-D)

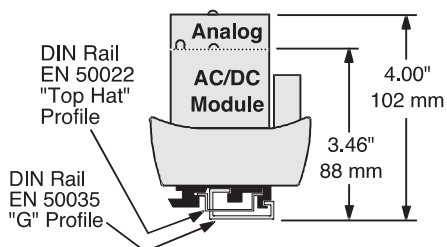

Notes:

- A **Slimline** module is required for each Input or Output used. See Appendix for module specs.
- AC and DC modules can be mixed as needed.
- Input modules can be used only with 5004 and 5104 units.
- Output modules act like switches; they do not supply power to loads.
- Analog modules may be installed in position 16 only.
- Module Fuses: 4 Amp, #PS-9005-0004 (Wickman 19370-K)
- **"A" Terminals:** (-) or load
"B" Terminals: (+) or hot

External 24 & 48 Module I/O Racks: Dimensions & Specifications

PS-5001
PS-5101
PS-5004
PS-5104

Standard 24 Rack: PS-4100-12-224

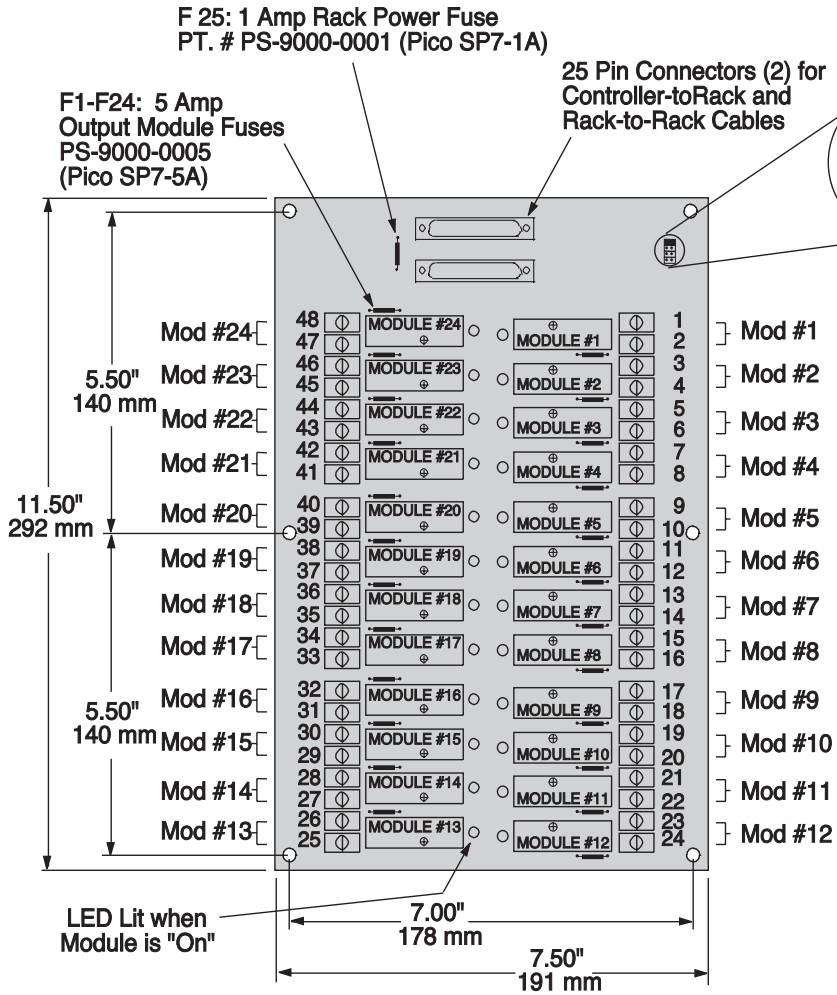

Notes:

- A **Standard** module is required for each Input or Output used. See Appendix for module specs.
- AC and DC modules can be mixed as needed.
- Input modules can be used only with 5004 and 5104 units.
- Output modules act like switches; they do not supply power to loads.
- Either 25 pin connector can be used to connect the rack to the controller. The other connector ties to a second rack for 48 I/O as shown below.
- **Odd Terminals:** (+) or hot
- **Even Terminals:** (-) or load

Configuration for 48 I/O System

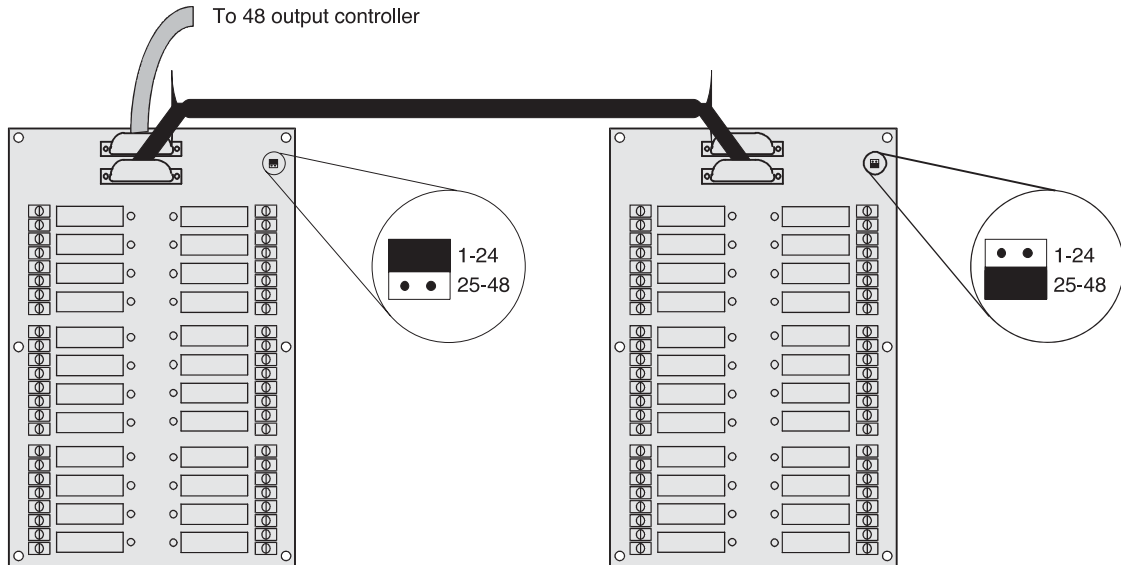

Slimline I/O Modules on Controller Back: Specifications

PS-5021
PS-5121
PS-5024
PS-5124

Back View of Controller Body

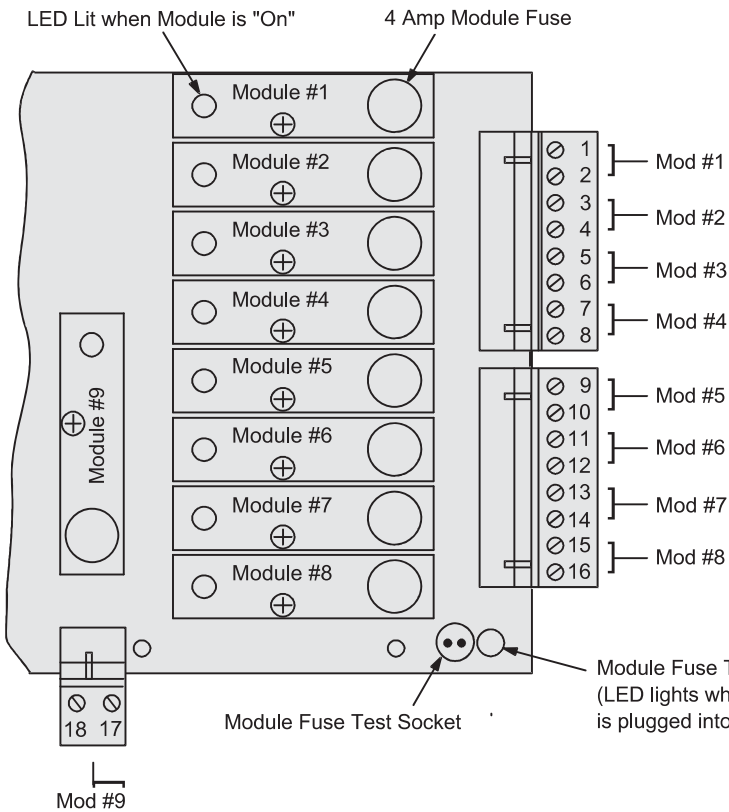

Notes:

- A module is required for each Input or Output used. See Appendix for module specs.
- AC and DC modules can be mixed as needed.
- Input modules can be used only with 5024 and 5124 units.
- Output modules act like switches; they do not supply power to loads.
- Analog modules may be installed in Position 9 only, and only on units ordered with option “-A”.
- Module Fuses: 4 Amp, #PS-9005-0004 (Wickman 19370-K)
- **Odd Terminals:** (+) or hot
- **Even Terminals:** (-) or load

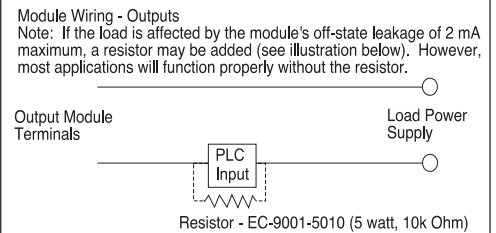

Module Wiring - Outputs

AC Output

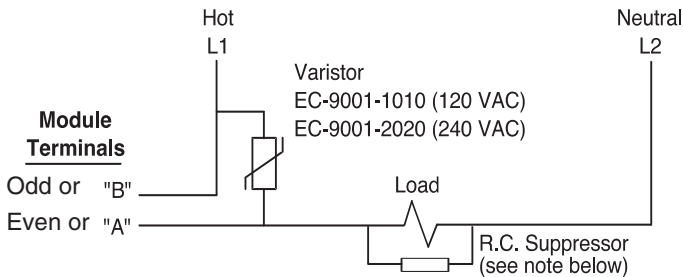

- Most applications will not need the varistor or R-C suppressor shown above. However, when other switching devices are in series or parallel with the AC module, voltage spikes may damage the module. Use one of the following two methods to suppress voltage spikes.
- For infrequent switching, connect a varistor (MOV) across the terminals.
- For continuous switching, wire an R-C suppressor in parallel with the load.

Analog Output

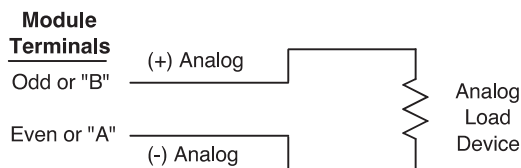

- Control must have Option “-A” to use analog output module.
- Analog output modules source the analog signal.
- Analog output signals are isolated.
- **Caution:** Do not apply external voltage to an analog module or you will damage it.

DC Output

Sourcing

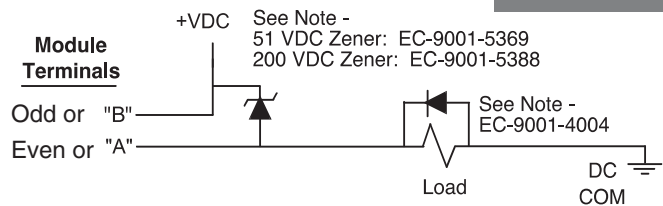

Sinking

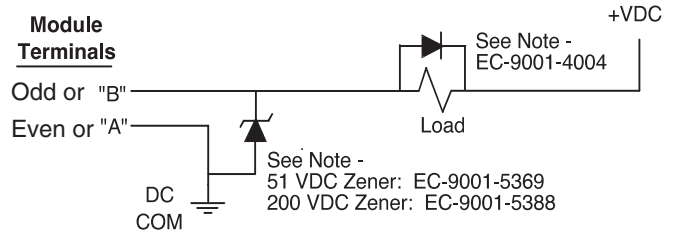

- Most applications will not need the diodes shown above. However, highly inductive DC loads may damage modules by generating voltage spikes when switched off. Suppress these loads using one of these two methods:
- Connect a Zener diode across the terminals. This will not significantly increase the load turn off time. Voltage rating of the diode must be greater than the normal circuit voltage.
- Connect a reverse-biased diode across the load. This may increase the load turn off time.

PS-5X01
PS-5X04
PS-5X21
PS-5X24

Sinking or Sourcing (as pertaining to Electro Cam Corp. products)

Sinking means that when the logic is true and the output (or input device) is ON, the output (or input device) is providing a DC common or ground to the connected device.

Sourcing means that when the logic is true and the output (or input device) is ON, the output (or input device) is providing a +DC voltage to the connected device.

This information is important when interfacing an Electro Cam Corp. product with another electronic device. If you are using an Electro Cam Corp. product input to an Allen-Bradley 1746-IN16 "sinking" input card* or similar A-B device, you have to supply a +DC voltage (Electro Cam Corp. **Sourcing** output) to this card, NOT a DC common or ground. In these cases, **Sinking** is what the card does with the input voltage; sinks it to common or ground.

*Other manufacturers include, but not limited to: Koyo (formerly GE Series 1, Texas Instruments, or Siemens SIMATIC PLS's) that use descriptions similar to Allen-Bradley.

Module Wiring—Inputs

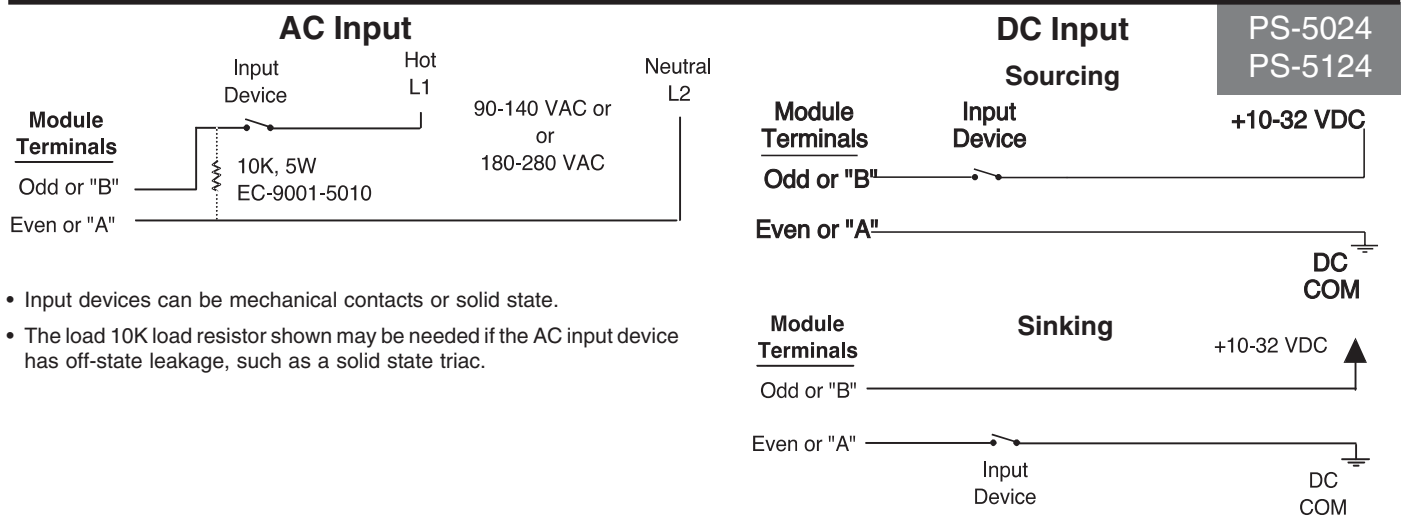

- Input devices can be mechanical contacts or solid state.
- The load 10K load resistor shown may be needed if the AC input device has off-state leakage, such as a solid state triac.

- Input devices can be mechanical contacts or solid state.
- 12 VDC power is available from the controller's logic terminal strip. See page 3-1 for details.

Input Wiring, 3-Wire Sensors

Using Logic Terminal Strip Power Supply (pg. 3-1)

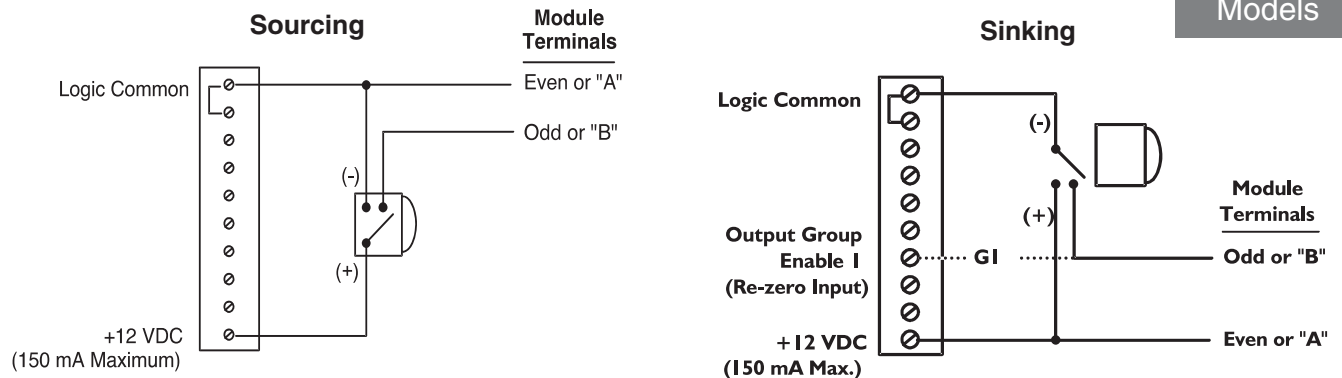

- For controllers using input/output modules.

- Module wiring applies only to controllers using input/output modules.
- Using sensor to switch terminal 7 can be done for any PS-5000 Series controller. See page 3-1 for details.

Using External Power Supply & Terminal 7

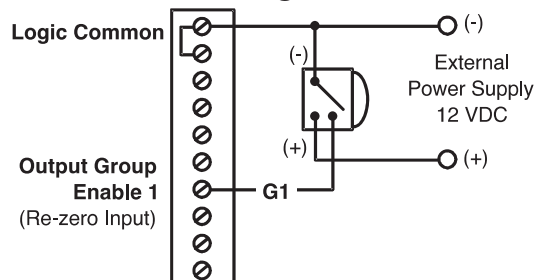

- Using sensor to switch terminal 7 can be done for any PS-5000 Series controller. See page 3-1 for details.

DC 8 Output Board

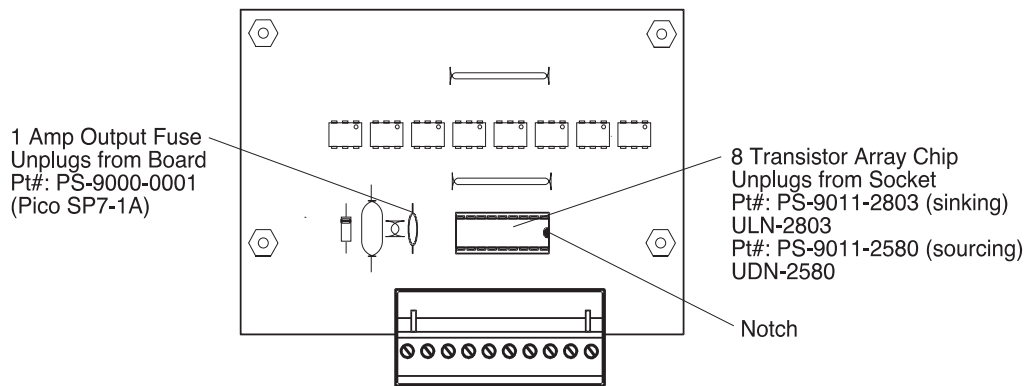

DC 16 Output Board

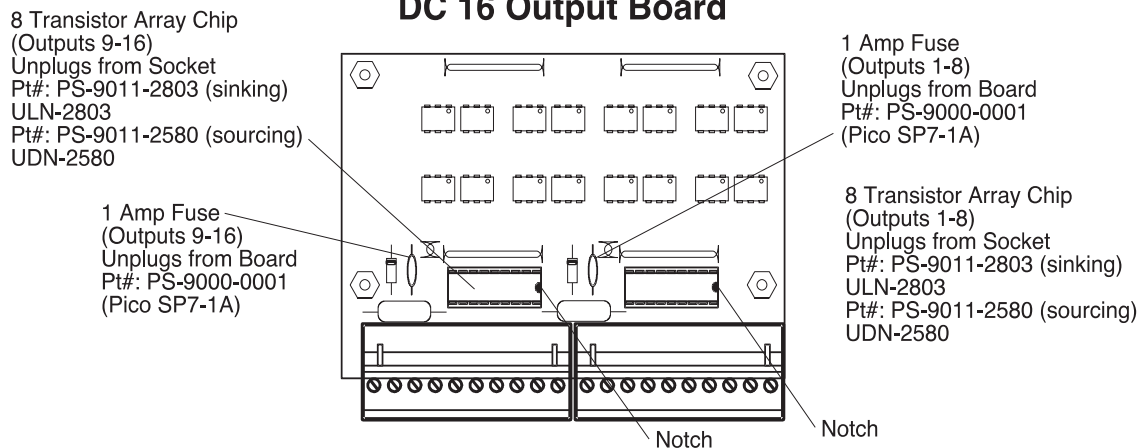

The output board which contains the output transistor array chips and the fuse(s) is located under the output board cover. The pluggable output terminal strips plug into receptacles that are mounted to the output board. The only time it will be necessary to remove the output board cover is when an output fuse is blown or a transistor array chip is damaged.

Output Transistor Array Chips:

Each group of 8 output transistors is contained in a single 18 pin transistor array chip. If one or more of these transistors becomes damaged, the chip can simply be unplugged from the socket and replaced. Note that Sinking and Sourcing output boards do not use the same transistor array chip.

Output Fuses:

Each group of 8 outputs (1 transistor array chip) is protected by a 1 Amp plug in fuse. This fuse will blow if the DC power polarity is incorrectly wired to the "+" and "-" terminals on the output terminal strip. On the sourcing output versions this fuse will also blow if the total amount of current being

conducted by that group of 8 outputs exceeds 1 Amp. If a fuse blows, all 8 of the outputs in that group will be inoperative until the fuse is replaced.

Output Cables:

Pluggable screw terminal strips are used to connect the transistor outputs to the load device. Therefore, no special connectors are needed for output wiring. However, shielded cable is recommended (Electro Cam part #: PS-4300-04-XXX, 2 cables required for systems with more than 8 outputs) to maximize immunity to electrical noise. The shield should be connected to the grounding screw located on the back panel just above the output terminal strips. The shield should be unconnected at the load end of the cable. Also, the cable should be kept away from other electrical wiring, especially control wiring involving solenoids, relays, contactors, and motors.

Built-In Transistor I/O Chips: Output Wiring, Sourcing

PS-5011
PS-5111

The actual sourcing output circuit uses a PNP transistor driving an NPN in an Emitter Follower Configuration. (A PNP transistor is pictured because it has the same operating characteristics and is normally associated with Sourcing outputs)

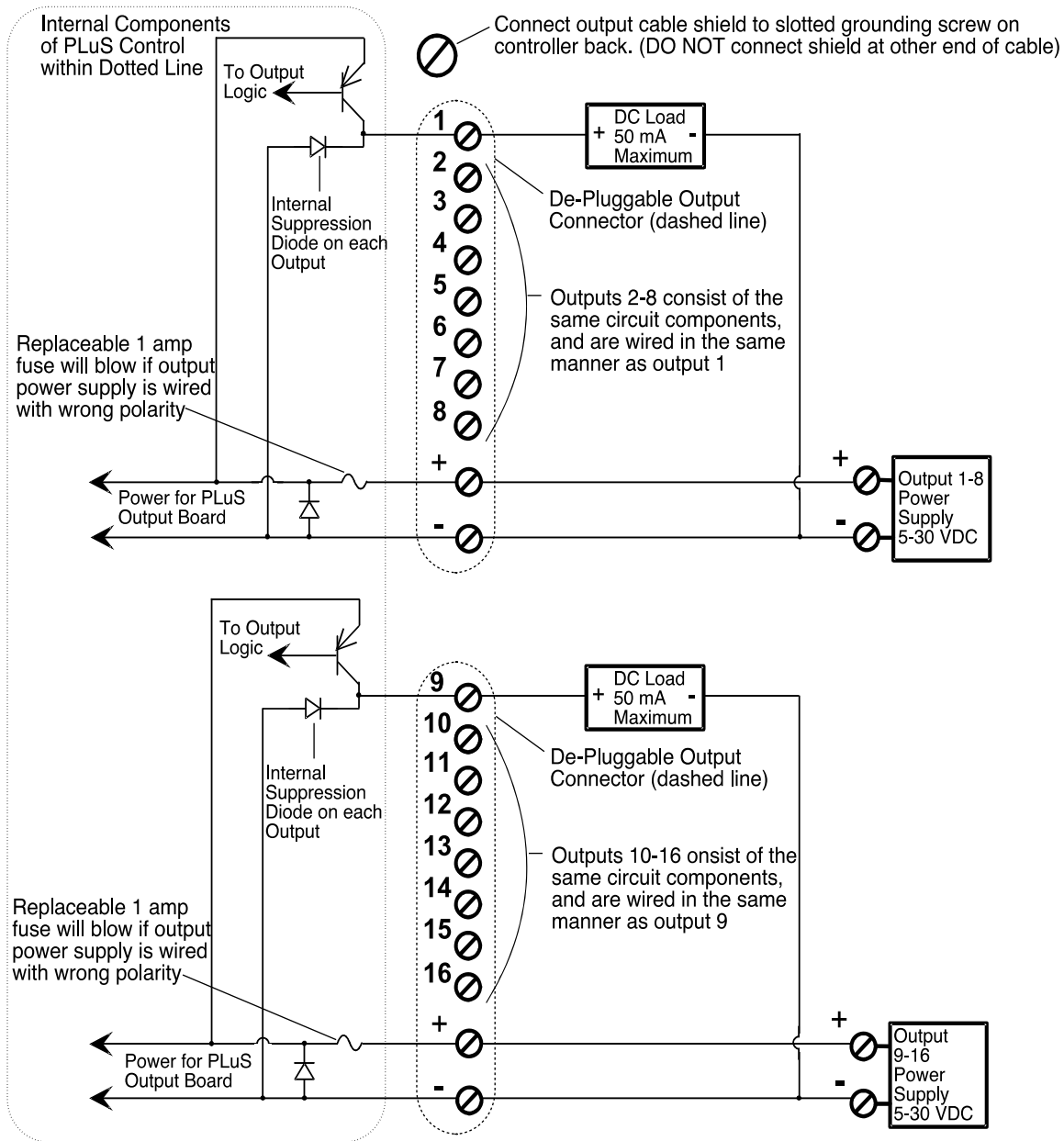

The output power supplies shown can be internal to the load device being driven. This will normally be the case when connecting to PLC's.

The loads connected to outputs 1-8 must all be powered from the same power supply.

The loads connected to outputs 9-16 must all be powered from the same power supply.

The same power supply can be used to power all 16 outputs by paralleling the wiring between the "+" and "-" terminals on the PLS output terminal strips.

The load power supply must be connected to both the "+" and "-" terminals on the output terminal strip(s).

The unpluggable output terminal strips are keyed so they can only be plugged into the correct receptacle.

Use shielded cable(s) for output wiring. Electro Cam 10 conductor cable part number PS-4300-04-XXX (XXX=length in feet) is recommended. Two cables required for 16 output units.

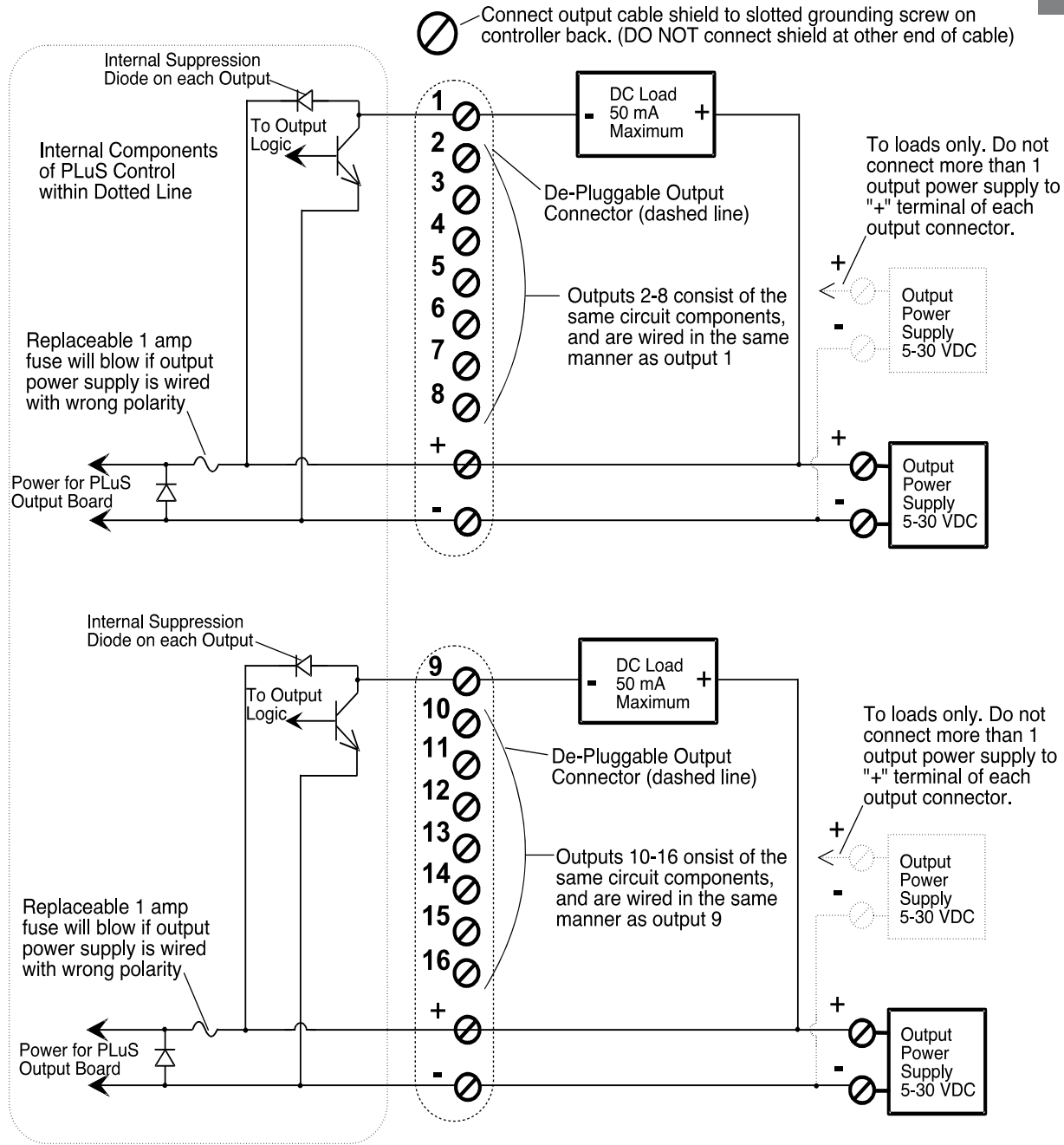

The output power supplies shown can be internal to the load device being driven. This will normally be the case when connecting to PLC's.

More than 1 power supply can be used to power loads within each group of 8 outputs. Only one of the power supplies used within the group can have its positive side connected to the "+" terminal of the corresponding 5011 output terminal strip. The common of each power supply used within a group of 8 outputs must be connected to the "-" terminal of the output terminal strip.

The same power supply can be used to power all 16 outputs by paralleling the wiring between the "+" and "-" terminals on the 5011 output terminal strips.

Both the "+" and "-" terminals on the output terminal strip(s) must be connected to a load power supply.

The unpluggable output terminal strips are keyed so they can only be plugged into the correct receptacle. Do not force when plugging them in.

Use shielded cable(s) for output wiring. Electro Cam 10 conductor cable part# PS-4300-XXX (XXX=length in feet) is recommended. Two cables required for 16 output units.

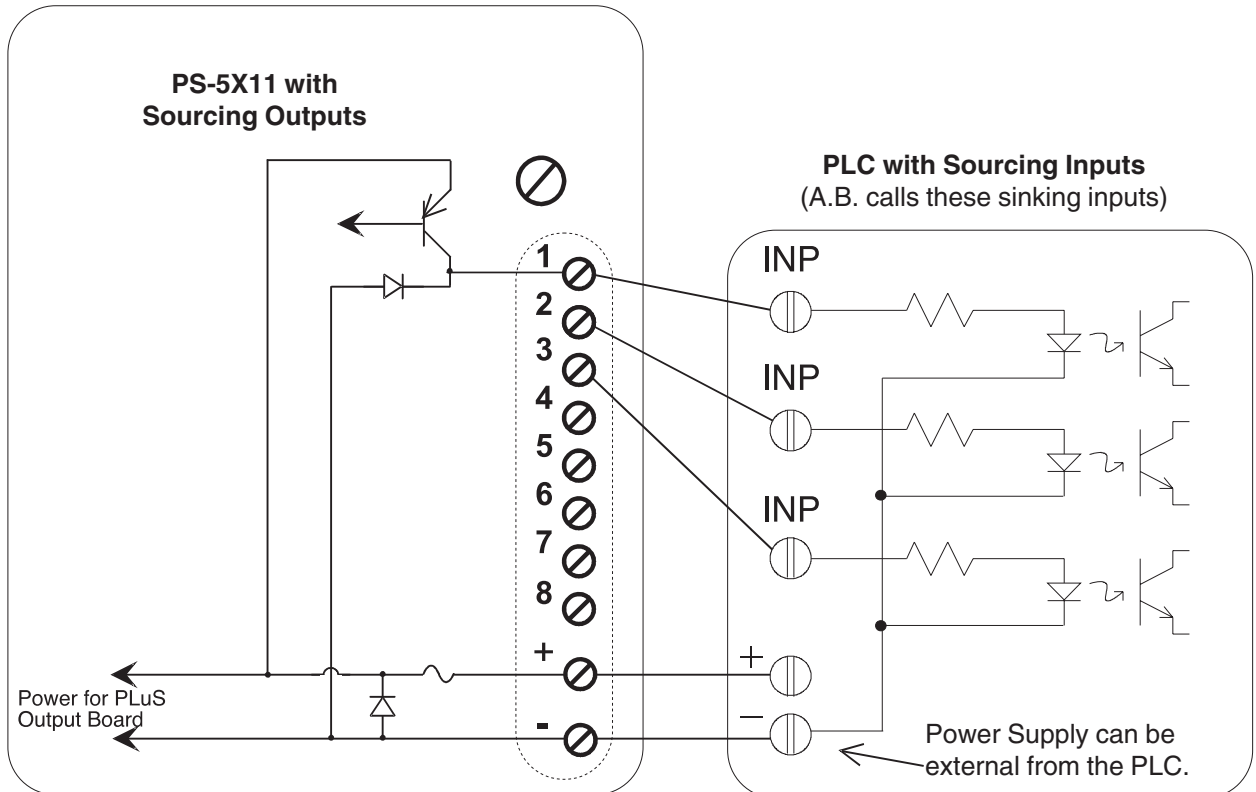
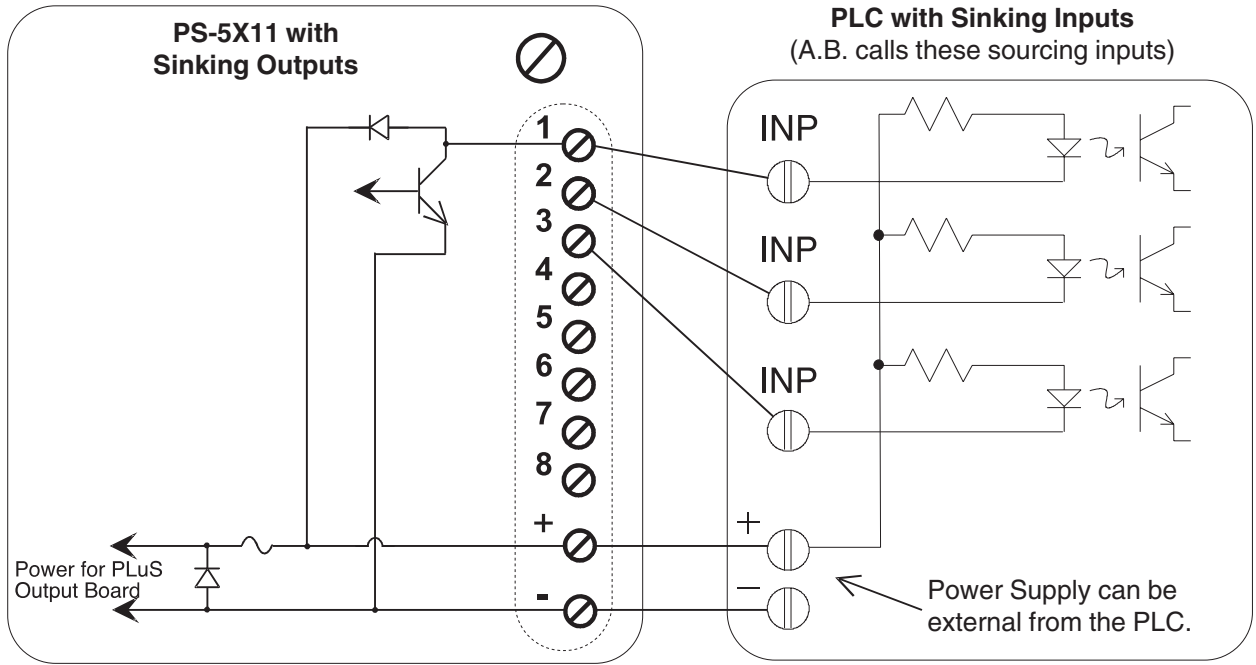

PS-5X34 Controller & 32 DC Output Rack

Introduction

The PS-5X34 system is available with either 32 or 64 low current transistor outputs. These systems are intended to be interfaced directly to PLCs or other control devices with low level DC inputs.

The 32 transistor output rack(s) used with PS-5X34 controls can be DIN rail mounted (-D) or foot mounted (-F) and are available with Sinking or Sourcing outputs.

Systems that require 32 or fewer outputs will only need one of the transistor output racks. Systems requiring more than 32 outputs need two transistor output racks daisy chained together (see rack configuration section below).

The PS-5X34 controller incorporates the same keyboard and features that other PS-5000 controls use. Because of the large number of outputs being controlled, the number of programs stored in a 32 output controller is 32, and the number of programs in a 64 output controller is 16.

This control has PS-5XX4 capabilities (output grouping and modes) and includes an RS-232/485 communications port. Outputs can be subdivided into as many as 8 groups, and the position of each of these groups can be offset individually. Because the rack transistor outputs cannot be configured as inputs, the only enable input available is the "Output Group Enable 1" input located on the logic strip. Output Group 1 can operate in any output mode, all other groups must operate in Mode 0 only.

PS-4100-12-X32-X Dimensioned Drawing

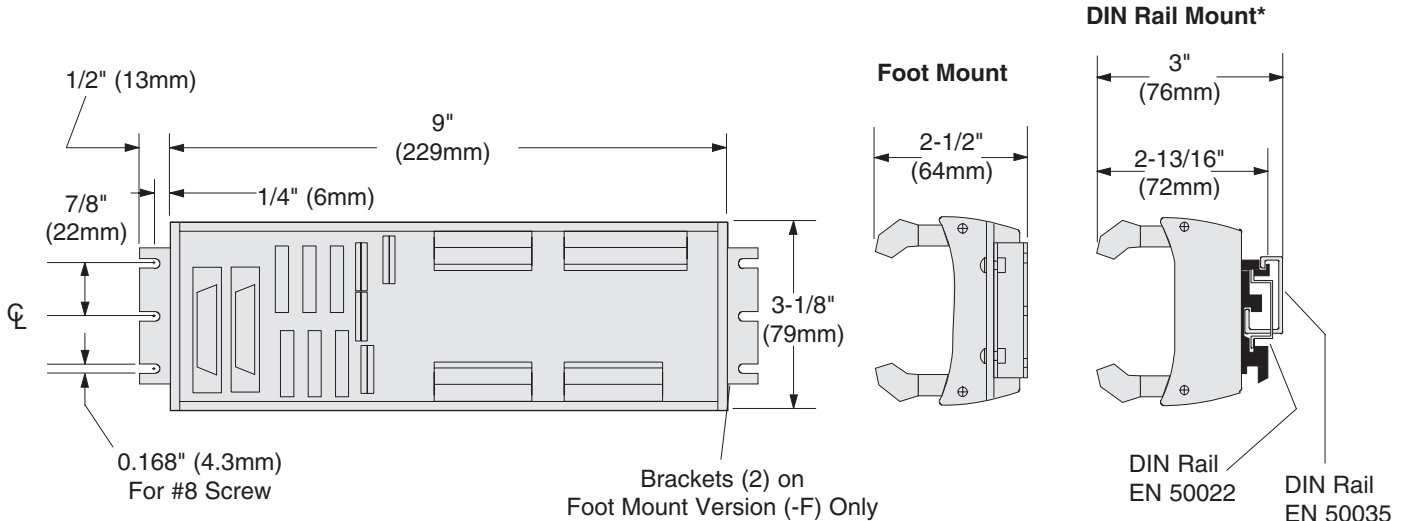

*DIN Rails must be ordered separately

Output Rack Configuration

Control systems requiring 32 or fewer outputs will need only 1 PS-4100-12-X32 transistor output rack. The "Rack Address Jumper" must be plugged into position 1. This will configure the outputs to be channels 1-32. 1 rack cable (Pt# PS-4300-02-XXX) will be needed to connect the rack to the controller.

Control systems requiring more than 32 outputs will need 2 PS-4100-12-X32 transistor output racks. The "Rack Address Jumpers" must be plugged into position 1 on one of the racks, and position 2 on the other. Output channel numbers will be assigned as shown in the illustration to the right. 2 rack cables (Pt# PS-4300-02-XXX) will be needed: one to connect the controller to the first rack and the other to connect the two racks.

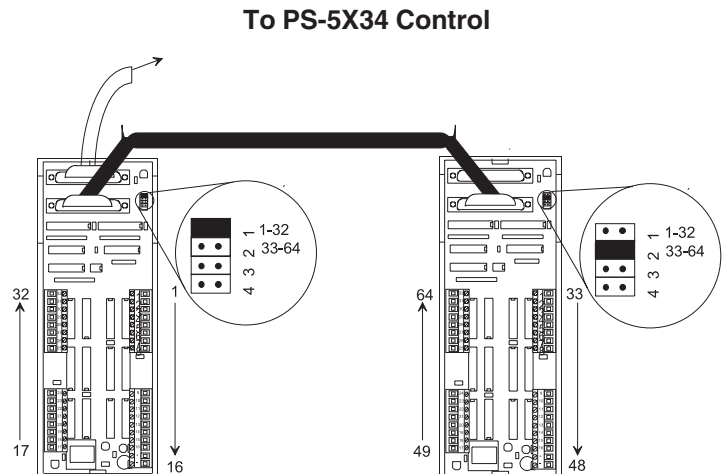

PS-5X34 System: Output Rack Layout

Sinking Output Rack Pt#: PS-4100-12-N32

Each Output can Sink 3-30 VDC, 100 mA Max

Sourcing Output Rack Pt#: PS-4100-12-P32

Each Output can Source 10-30 VDC, 100 mA Max

DB 25 Connectors (Female)

Connect to PLS controller or another rack
(these connectors can be used interchangeably)

PLμS Power LED

On when PLS control is powered up and connected to rack

Rack Address Jumper

- 1: Channels 1-32
- 2: Channels 33-64
- 3: Unused
- 4: Unused

(Jumper shown in position 1)

Transistor Array Chips

(socketed for field replacement)

E.C. Pt#: PS-9011-2803

Generic Pt#: ULN-2803

Output Terminals 1-8

E.C. Pt#: PS-9006-0011

(unpluggable)

Transistor Array Chips on Sourcing Output Racks

(socketed for field replacement)

E.C. Pt#: PS-9011-2580

Generic Pt#: UDN-2580

OR

Dip Jumper Blocks on Sinking Output Racks

E.C. Pt#: PS-9006-0015

Output Terminals 9-16

E.C. Pt#: PS-9006-0012

(unpluggable)

User DC Power Input

10 - 30 VDC, 4 Amp Max

(Sinking outputs switch "-")

(Sourcing outputs switch "+")

User DC Power Fuses

4 Amps (F1= "+", F2="-")

E.C. Pt#: PS-9005-0004

Wickman Pt#: 19370-K

Output Terminals 25-32

E.C. Pt#: PS-9006-0014

(unpluggable)

Output Terminals 17-24

E.C. Pt#: PS-9006-0013

(unpluggable)

User Power LED

On when user power applied to rack
(will NOT be on if user power fuse is blown)

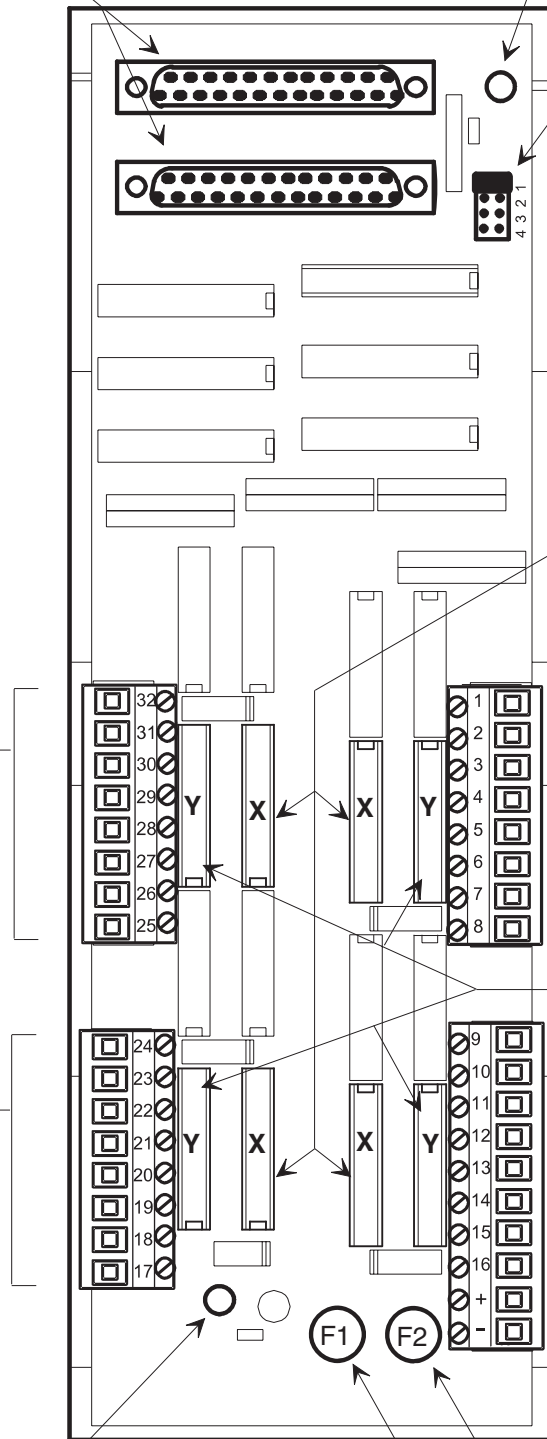

PS-5X34 System: Wiring to PLCs

Wiring to a PLC with Sinking Inputs

(A.B. calls these Sourcing Inputs)

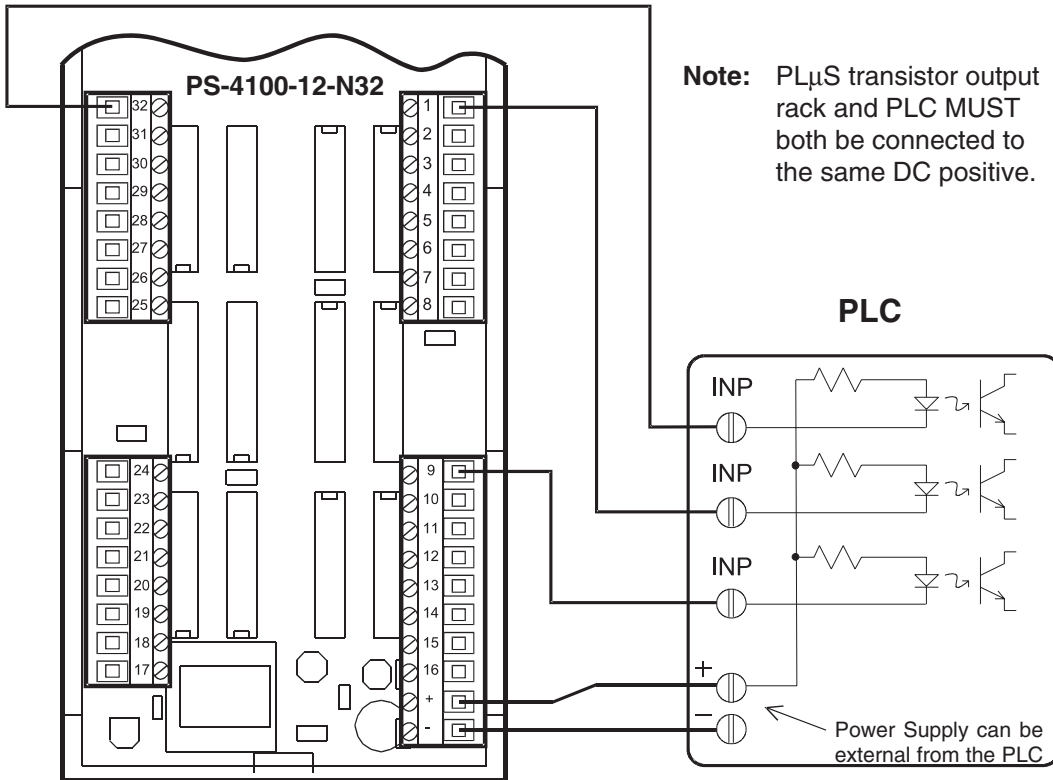

Wiring to a PLC with Sourcing Inputs

(A.B. calls these Sinking Inputs)

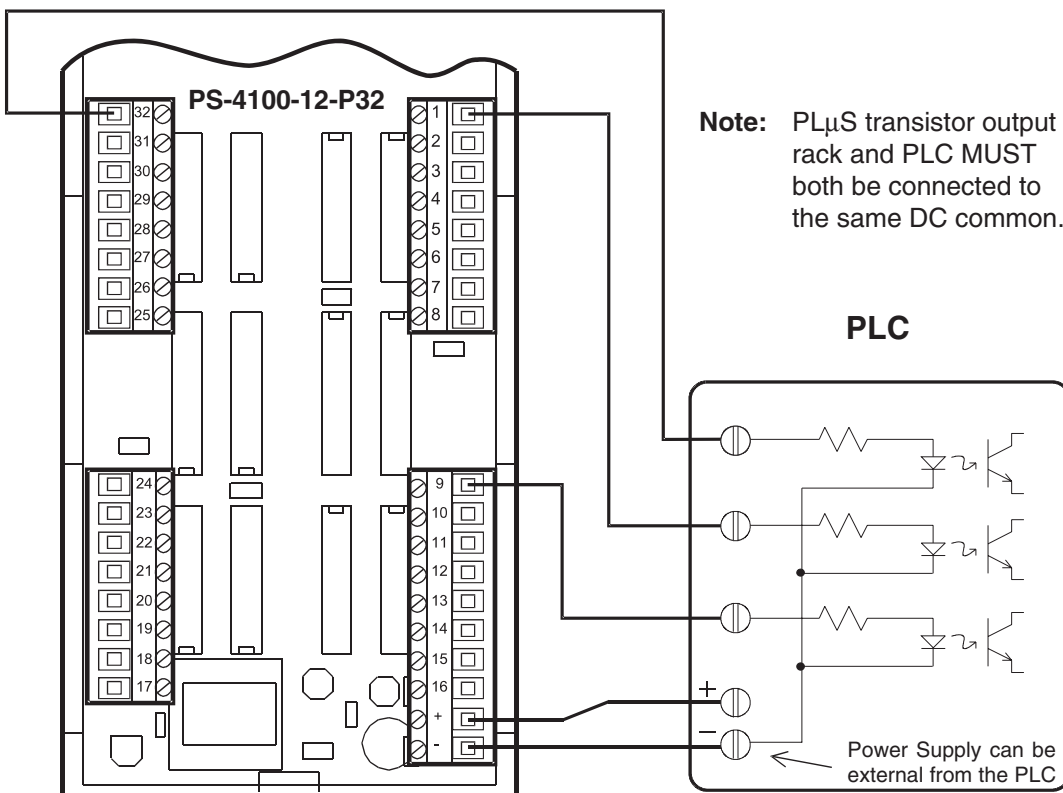

Transistor Array Chip Layout on PS-4100-12-N32 Sinking Output Rack

PS-4100-12-N32

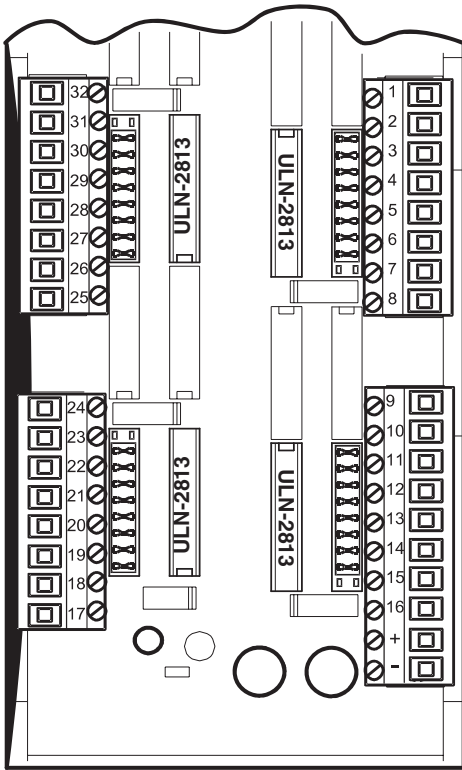

The output circuits of the Sinking and Sourcing output boards are powered through the "User Power Fuses." If the outputs on these boards are malfunctioning, **check that both fuses are good before investigating the transistor array chips.** If the fuses are good, the "User Power LED" will be lit. When either fuse is blown, the LED will not light and all 32 outputs will be dead. **Verify that "User DC Power" is present.**

The transistor array chips and jumper blocks used on the Sinking board are socketed for field replacement. In the event of a wiring error or accidental short circuit, it is possible to damage one or more array chip. In these situations, replacing the ULN-2813 chip(s) will usually correct the problem. The orientation of these chips is critical with respect to their notched ends. **Insure that all chips are oriented in the direction shown in the illustration to the left.**

The jumper blocks installed in the sockets next to the terminal strips do NOT short together all 9 sets of parallel socket holes - one set is left open. Insure that the open set of holes is at the correct end of the corresponding socket as pictured in the illustration to the left. **A connection between these two holes will short out the "User DC Power" supply and cause one of the "User DC Power Fuses" to blow.**

Part Numbers

- Sinking Transistor Array Chip: E.C. PT# PS-9011-2803
Generic PT# ULN - 2803
- 16 Pin Dip Jumper Block: E.C. PT# PS-9006-0015

Transistor Array Chip Layout on PS-4100-12-P32 Sourcing Output Rack

PS-4100-12-P32

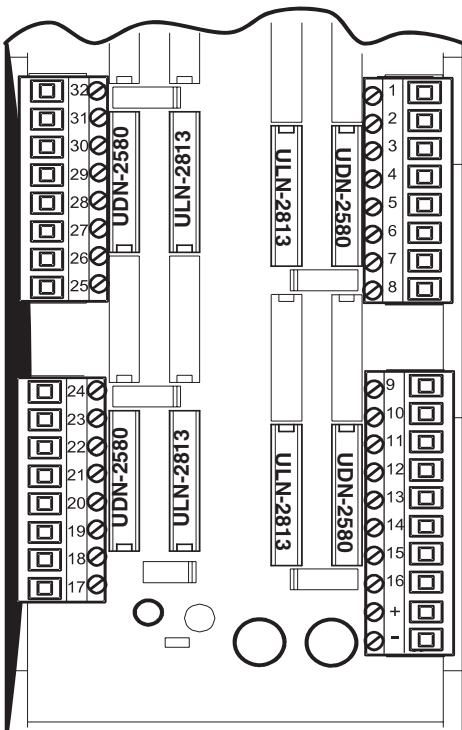

The output circuits of the Sinking and Sourcing output boards are powered through the "User Power Fuses." If the outputs on these boards are malfunctioning, **check that both fuses are good before investigating the transistor array chips.** If the fuses are good, the "User Power LED" will be lit. When either fuse is blown, the LED will not light and all 32 outputs will be dead. **Verify that "User DC Power" is present.**

Two types of transistor array chips are used on the Sourcing board. They are all socketed for field replacement. In the event of a wiring error or accidental short circuit, it is possible to damage one or more array chip. In these situations, replacing the UDN-2580 chip(s) will usually correct the problem. The orientation of the array chips is critical with respect to the notched end of the chips. **Insure that all chips are oriented as shown in the illustration to the left.**

Part Numbers

- Sourcing Transistor Array Chip: E.C. PT# PS-9011-2580
Generic PT# UDN-2580
- Sinking Transistor Array Chip: E.C. PT# PS-9011-2803
Generic PT# ULN - 2803

Resolver Wiring and Dimensions

STANDARD RESOLVER CABLES

PT# PS-5300-01-XXX (XXX = LENGTH IN FEET)

Connector - Controller End

PT# PS-5300-01-TER

(Weidmuller # BLA7 12822.6)

Connector - Resolver End

PT# PS-5300-01-MSC

(ITT Cannon # KPT-06-F-12-10-S)

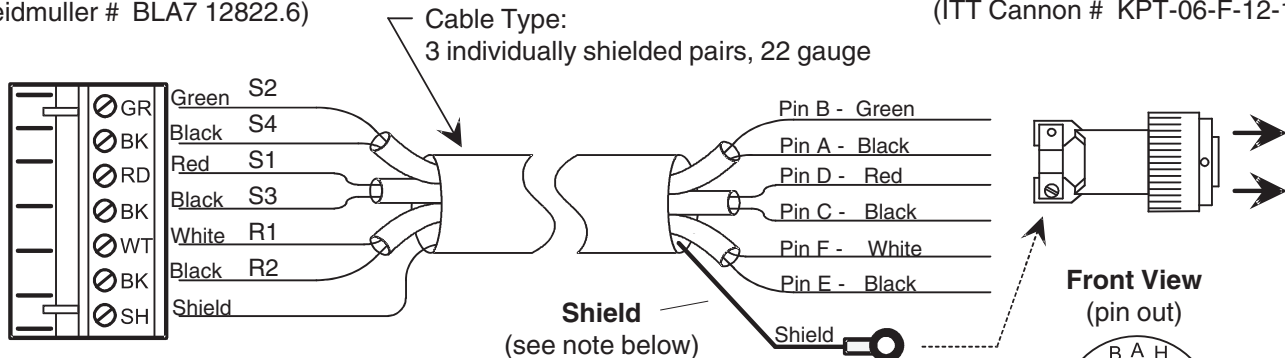

Shielding Note: Resolver cables made after 3-2-93 have a ring lug on a black shield wire at the resolver end. The ring lug should be attached to one of the resolver connector strain relief screws to protect against static discharge through the resolver cable. In some installations, it may be advisable to disconnect the ring lug to prevent ground loops through the cable shield. Consult Electro Cam if electrical noise problems are suspected.

⊗ = Not Used

RESOLVER DIMENSIONS

Foot Mount Resolver - 3/4" Shaft

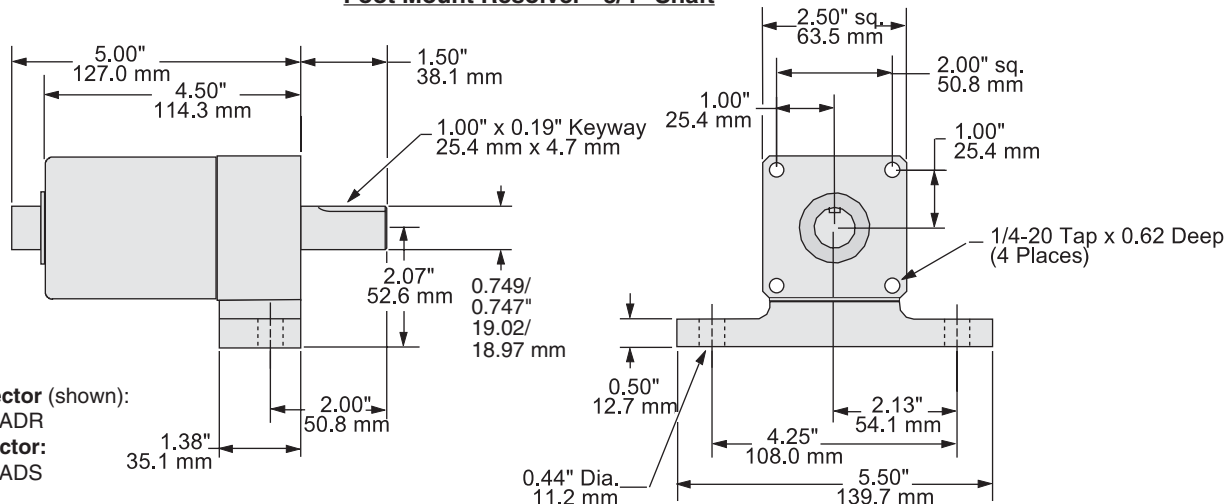

With Rear Connector (shown):

PS-5275-11-ADR

With Side Connector:

PS-5275-11-ADS

Cable:

PS-5300-01-XXX where "XXX" is length in feet.

Flange Mount Resolver - 3/8" Shaft

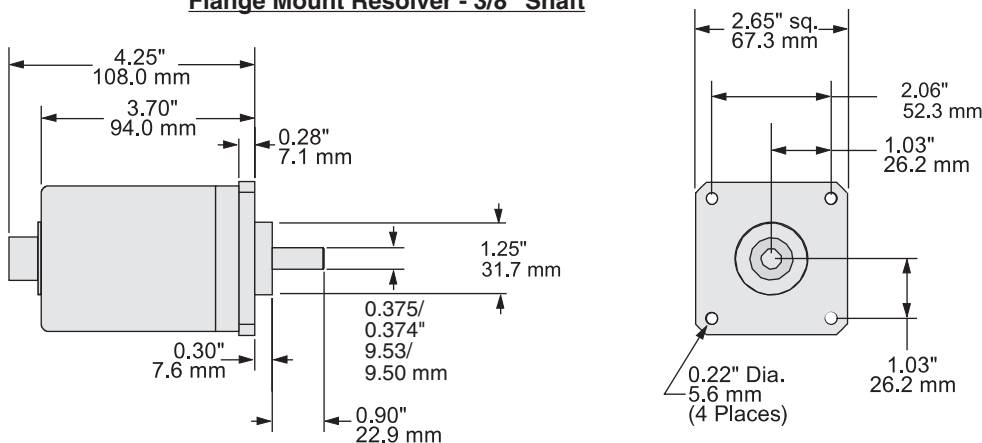

With Rear Connector (shown):

PS-5238-11-ADR

With Side Connector:

PS-5238-11-ADS

Cable:

PS-5300-01-XXX where "XXX" is length in feet.

Resolver Wiring and Dimensions

Flange Mount Resolver - 5/8" Shaft

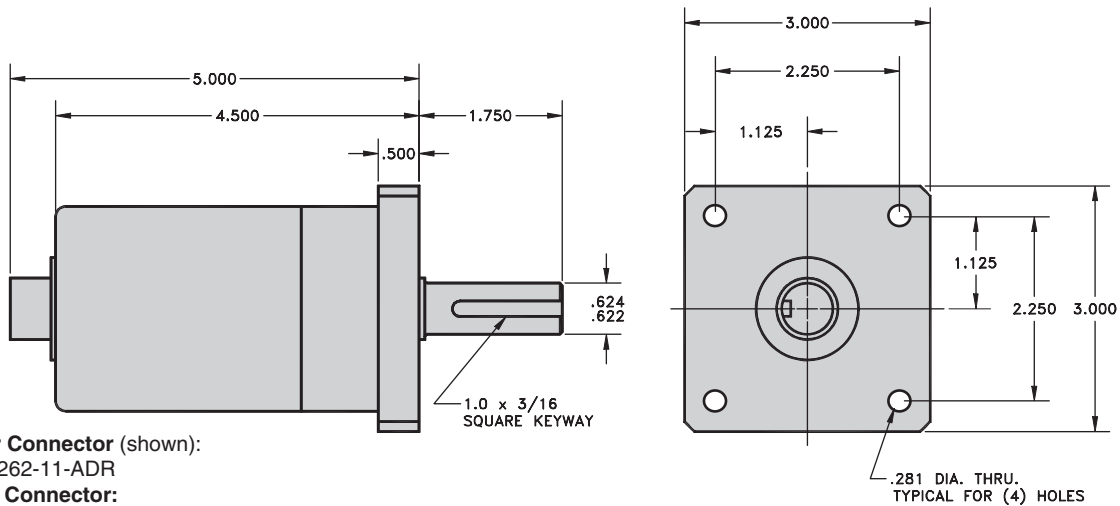

With Rear Connector (shown):
PS-5262-11-ADR

With Side Connector:
PS-5262-11-ADS

Cable:
PS-5300-01-XXX where "XXX" is length in feet.

STAINLESS STEEL RESOLVER

Cable for Stainless Steel Resolver with Terminal Strip Connections

Connector - Controller End

PT# PS-5300-01-TER
(Weidmuller # BLA7 12822.6)

PT# PS-5300-02-XXX (XXX = Length in Feet)

Cable Type:
3 individually shielded pairs, 22 gauge

Connector Inside Resolver

(cable is stripped and tinned at both ends)

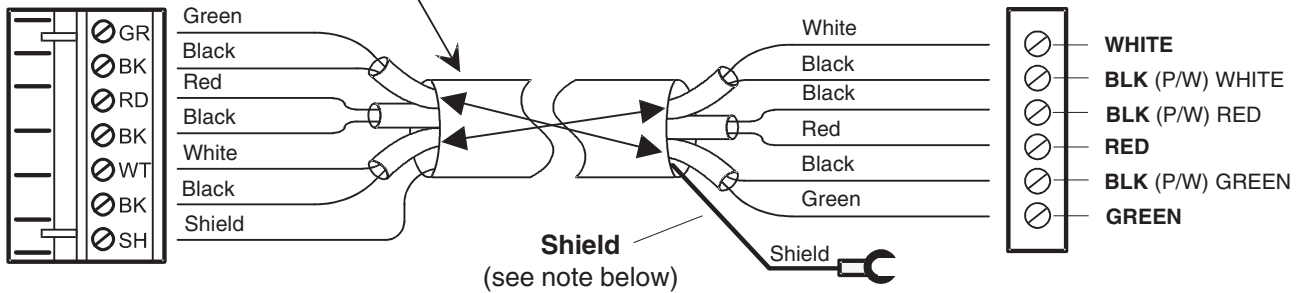

Shielding Note: This type of resolver cable will have a spade lug connected to the shield at the resolver end. The lug should be attached to the grounding stud on the cover plate of the resolver. In some installations, it may be advisable to disconnect the lug to prevent ground loops through the cable shield. Consult Electro Cam if electrical noise problems are suspected.

Stainless Steel Foot Mount Resolver - 5/8" Shaft

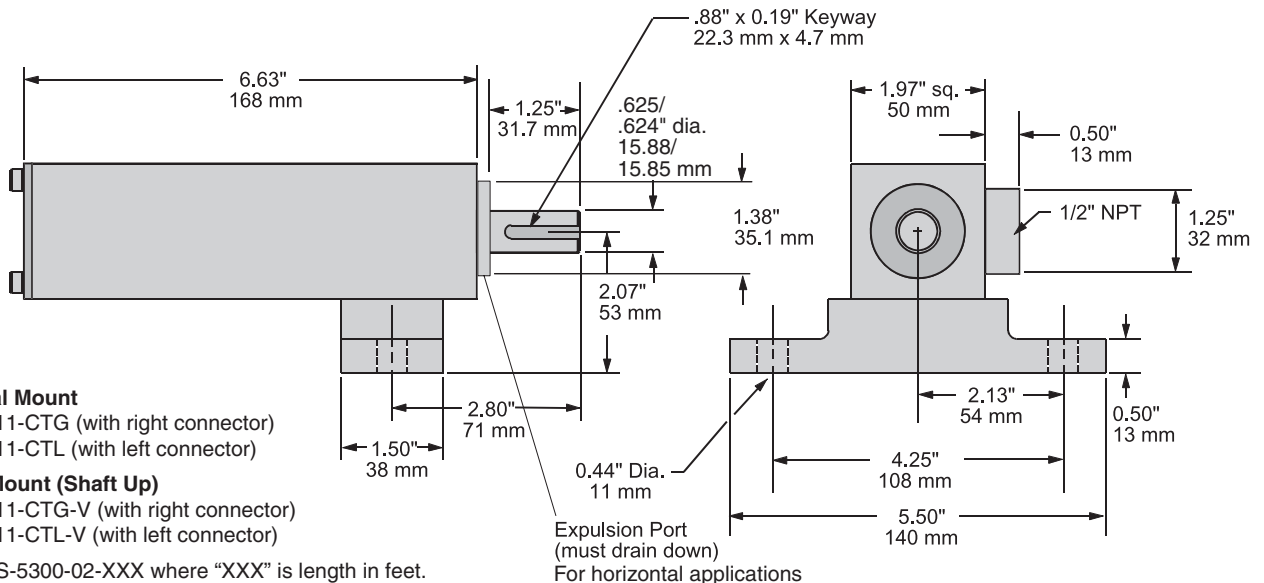

Horizontal Mount
PS-5262-11-CTG (with right connector)
PS-5262-11-CTL (with left connector)

Vertical Mount (Shaft Up)
PS-5262-11-CTG-V (with right connector)
PS-5262-11-CTL-V (with left connector)

Cable: PS-5300-02-XXX where "XXX" is length in feet.

Encoder Cable Installation

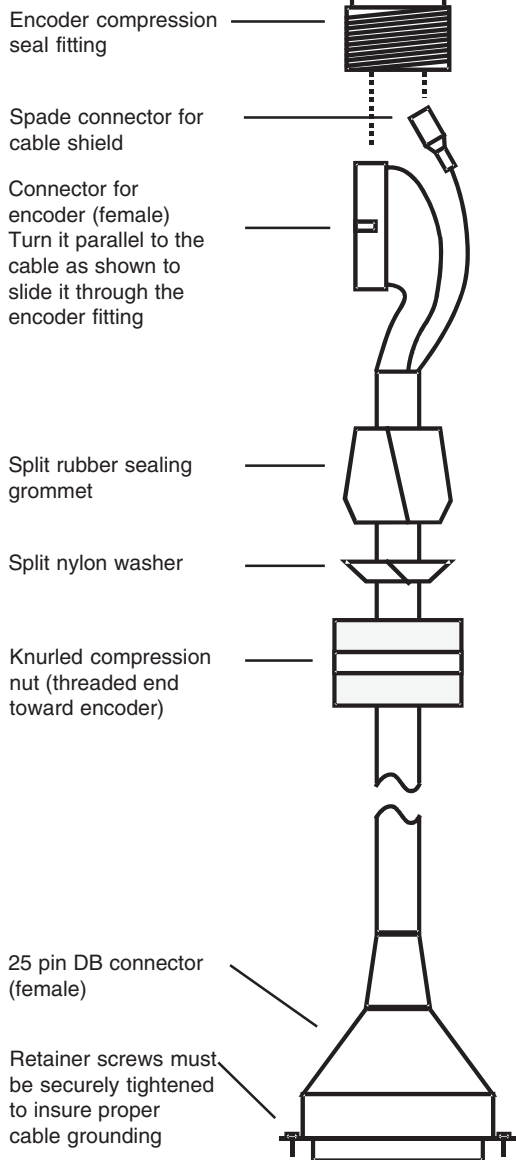
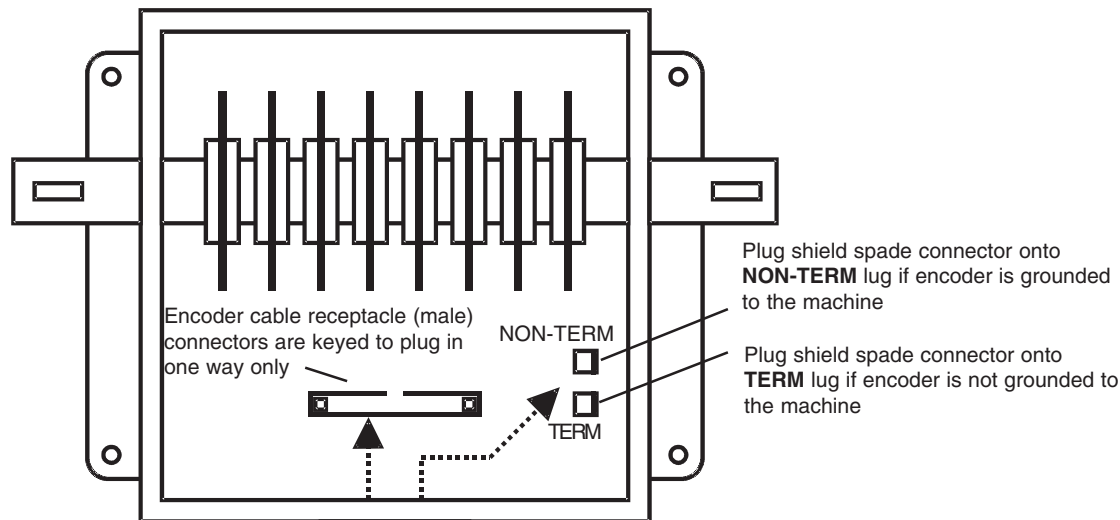

Note: The encoder cable can be pulled through 3/4" or larger conduit. Pull the cable from the controller to the encoder. Turn the encoder connector (rectangular) parallel to the cable (as pictured to the left) and tape it in this position while it is being pulled. Pull the connector through conduit before following the cable installation steps below.

A bulkhead connector assembly (PS-4300-09-XXX) is available for installations where it is desirable to unplug the encoder cable from the control enclosure.

Installation Procedure

1. Turn encoder connector (rectangular) parallel to cable and slide knurled compression nut over it. Threaded end of nut must face encoder connector.
2. Slip the nylon friction washer and the rubber sealing grommet onto the cable by opening up the splits.
3. Turn encoder connector parallel to the cable and slide it through the encoder compression seal fitting.
4. Plug encoder connector into the receptacle, making sure that raised key on connector mates with the key slot in the receptacle.
5. Plug the shield spade connector onto the "NON-TERM" spade lug if the encoder is grounded to the machine, or onto the "TERM" lug if the encoder is not grounded.
6. Slide the rubber grommet, nylon washer, and compression nut up to the compression fitting. Thread on the compression nut. Push a small amount of cable into the encoder to insure that it isn't pulling on the connector as the compression nut is tightened.
7. Put lid back on encoder. Operating without the lid can allow dust and other contamination to affect proper operation of the encoder.

Programming Access Levels

Levels of Programming Access

The 5000 Series of controls have three levels of programming access. Entry into these levels of programming is accomplished through dedicated hardware inputs and/or programmable enable codes entered through the keyboard.

Master Level—Accesses all programmable features. In addition to all setpoints and functions, the Master Level also establishes the keyboard entry codes for the “Setup” and “Operator” access levels. Master Level programming also determines which outputs are accessible to the operator.

NOTE: On units prior to date code 9740, operator access was limited to setpoints and timed output values, unless equipped with the Expanded Operator Access (-E) option.

Setup Level—Accesses all output setpoints and the functions listed on the keyboard. These are control aspects that may need occasional adjustment, but go beyond normal operator responsibilities.

Operator Level—Functions available as specified in Master Level programming. The operator is allowed to change the following settings for output channels designated in FCN 6:

- Setpoints
- Timeouts
- Motion Detection Settings
- Offset
- Active Program Number
- Speed Comp Settings

The table below details which functions and set points can be changed at the three levels of programming access. It also indicates if the programming access levels can be accessed by hardware input and/or keyboard enable code.

FEATURE	MASTER	SET UP	OPERATOR
Enable Method	hardware	code	hardware / code
Output Set Points	All	All	Selected
Output Time Out Values	All	All	Selected
Motion Set Points	Yes	Yes	Selected
Offset	Yes	Yes	Selected
Active Program	Yes	Yes	Selected
Speed Compensation	Yes	Yes	Selected
Direction of Rotation	Yes	No	No
Scale Factor	Yes	No	No
Set Up Enable Code	Yes	No	No
Operator Enable Code	Yes	No	No
Time Base Selection	Yes	No	No
Motion ANDED Outputs	Yes	No	No
Select Operator Outputs	Yes	No	No
Output Enable Modes	Yes	No	No
OPTIONAL FEATURES:			
Lead/Trail Speed Comp	Yes	No	No
Communication Setup	Yes	No	No
Analog Setup	Yes	Yes	Selected

Logic Terminal Strip

- LOGIC COMMON
- PROGRAM SELECT 1
- PROGRAM SELECT 2
- PROGRAM SELECT 3
- MASTER PROGRAM ENABLE
- OUTPUT GROUP ENABLE 1
- MOTION DETECTION OUTPUT
- OPERATOR PROGRAM ENABLE
- +12VDC OUT - 150 mA MAX

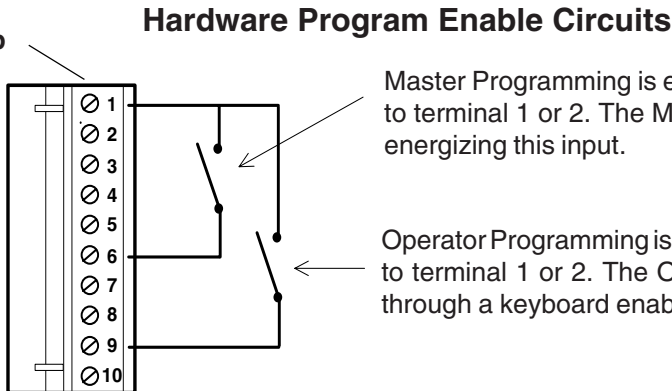

Master Programming is enabled when terminal 6 is connected to terminal 1 or 2. The Master Level can only be accessed by energizing this input.

Operator Programming is enabled when terminal 9 is connected to terminal 1 or 2. The Operator Level can also be accessed through a keyboard enable code.

Keyboard Enable Codes for Setup and Operator Access

Either the Setup or Operator programming levels can be accessed by entering the corresponding program enable code through the keyboard. These codes can be 1, 2, 3, or 4 digit numbers and are established during Master Level programming.

To Enter a program enable code number press:

FCN 0 ENT 1st digit 2nd digit 3rd digit 4th digit ENT

The PE codE message will disappear when a valid enable code is entered.

The level of access gained depends upon which code number is entered.

Programming access will time-out approximately 5 minutes after the last keystroke. To cancel access before the 5 minute time-out press:

FCN 0 ENT CLR/CLE ENT

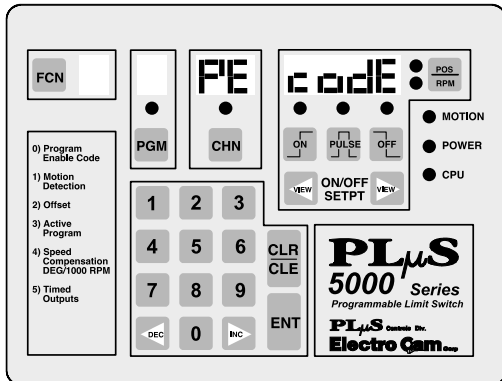

Keyboard Layout, Keys and Indicators

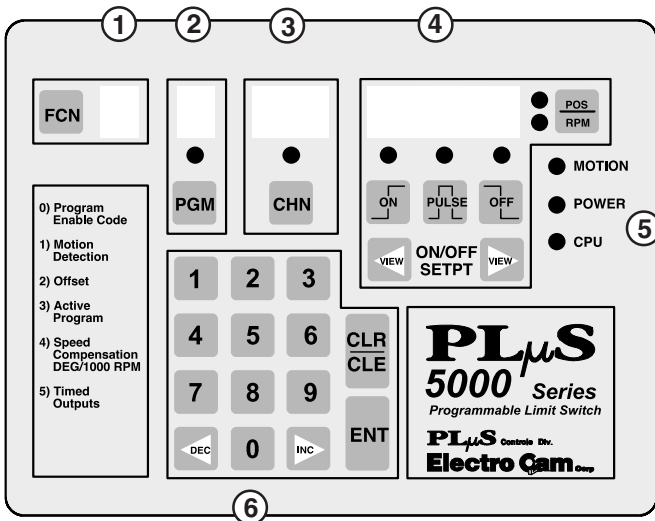

1 - Function Key and Display

The **FCN Key** is used to access the controls functions. The FCN number accessed will be displayed in the display next to the FCN key.

2 - Program Key, LED and Display

The **PGM key** allows programs other than the current active program to be viewed and or edited. The program number selected for viewing/editing is shown in the display directly above the PGM key. **When the PGM LED is lit, the program number displayed is also the current active program.**

3 - Channel Key, LED and Display

The **CHN key** allows the desired output channel to be selected for setpoint viewing/programming. The selected channel number is shown in the display directly above the CHN key. When the CHN LED is lit, the channel currently selected is in the ON state.

The CHN key is also used to select channel numbers during Function programming. Details are given in the programming sections.

4 - Value Display, Position/RPM Key and LEDs, ON Key and LED, PULSE Key and LED, OFF Key and LED, and View Keys

The **POS/RPM key** selects between Position and RPM being shown in the value display immediately to the left of the key. The corresponding POS or RPM LED will be lit when either item is displayed. **Pressing the POS/RPM allows programming functions to be exited/aborted and returns the control to displaying Position or RPM.**

The **ON and OFF keys** are used to specify the ON and OFF pulse edges during setpoint programming. The corresponding ON and OFF LEDs will be lit during these

setpoint programming operations. (The ON and OFF keys and LEDs are also used when programming the optional leading and trailing edge speed compensation feature).

The **VIEW keys** allow the current On and Off setpoints of the currently selected channel to be displayed in sequence, one at a time. The corresponding ON or OFF LED will be lit to indicate whether an ON or OFF edge is currently displayed. The >VIEW key displays the setpoints in increasing numeric order, the <VIEW key displays them in decreasing numeric order.

The **PULSE key** allows setpoint pairs (pulses) to be incremented and decremented simultaneously. When the PULSE LED is lit steadily, the pulse (both edges) whose edge is currently displayed will increment and decrement when the INC and DEC keys are pressed. Pressing the PULSE key a second time will cause the LED to blink. This indicates that the multi-pulse mode is activated and all of the pulses in the currently selected output channel will increment and decrement when the INC and DEC keys are pressed.

5 - MOTION, POWER and CPU LEDs

The **Motion LED** is lit whenever the machine speed is within the current motion setpoints (FCN 1).

The **Power LED** is lit whenever the PLuS control is powered up.

The **CPU LED** only lights when a Fatal error condition is detected by the controller. A list of error conditions is detailed on page A-12 of this manual.

6 - Numeric Keys, CLR/CLE Key, ENT Key, INC and DEC Keys

The **number keys** are used to input all numeric values needed during setpoint and function programming.

The **CLR/CLE key** is used to clear numeric values during programming operations.

The **ENT key** is used to actually enter numeric values into the controller after they have been keyed in. Failing to press ENT when programming numeric values will result in the old value remaining in the control's memory. Numeric value changes must be "Entered" by pressing the ENT key before they are accepted by the controller.

The **INC and DEC keys** cause numeric values that are displayed in the controls POS display to be incremented and/or decremented each time the corresponding key is pressed. Output setpoints, speed compensation and timed output values are examples of items that can be incremented and decremented with the INC and DEC keys.

Output Setpoint Programming

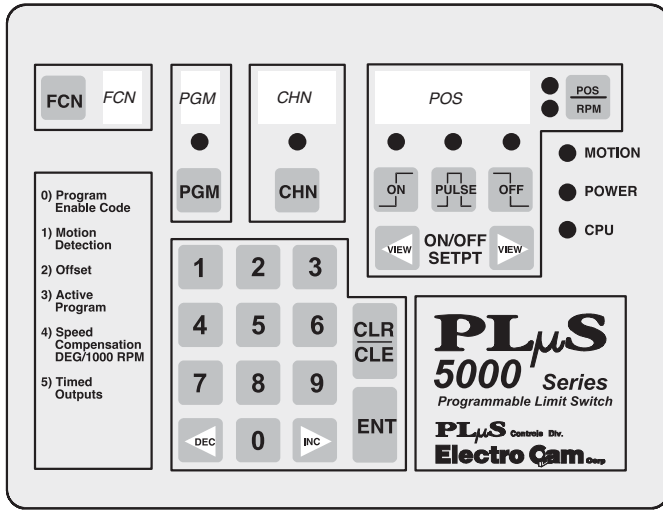

Programming Error Messages

Flashing error messages indicate programming mistakes as they occur.

Simply press **CLR** to cancel flashing error message.

- E1 OLAP:** Output pulse just attempted overlapped an existing output pulse on same channel.
- E2 -run:** Attempted programming can NOT be done while machine is running (transducer is turning).
- E4 -Pro:** Program enable Off when programming was attempted.
- E5 8888:** Value entered NOT valid for item being programmed.
- E6 -379:** Invalid setpoint entered: A setpoint ending in 3, 7, or 9 was entered. (Encoder Only - Exceptions: 89, 179, 269, and 359)
- E7 -dEF:** Attempted to program too many Enable Inputs (FCN 9).
- E9-tdE:** Attempted to program too many timed outputs (FCN 5).
- E11-ScE:** Attempted to program more than 16 speed compensated outputs (48 I/O controls only).

See pgs. A-12 thru A-14 for more details on error messages.

Output Setpoint Programming

Desired output channel **MUST** be selected before its setpoints can be created, viewed, adjusted, or cleared.

SELECT OUTPUT CHANNEL

If POS or RPM led NOT lit press:

POS RPM	CHN	1	6
POS or RPM led now lit	CHN and POS displays blank	1st Digit shown in CHN display	2 Digit value in CHN display

Channel 16 used as example.

VIEW SETPOINTS

View setpoints of output channel presently selected.

VIEW	VIEW	VIEW	VIEW
ON/OFF setpoints shown in position display in increasing order with ON and OFF LEDs. 0 is shown and both LEDs off if no setpoints exist.	ON/OFF setpoints shown in position display in decreasing order with ON and OFF LEDs. 0 is shown and both LEDs off if no setpoints exist.		

CREATE SETPOINTS

To create setpoints in output channel presently selected.

ON	3	0	
On led lit, POS blank	1st Digit shown in POS display	2 Digits shown in POS display	
On at 30 degrees used as example.			
OFF	6	0	ENT
OFF led lit, POS blank	1st Digit shown in POS display	2 Digits shown in POS display	POS display blinks once to confirm setpoint entry.
Off at 60 degrees used as example.			

Note: When entering multiple pulses, press **ENT** after each pulse.

CHANGE SETPOINTS

To change setpoints in output channel presently selected.

INC/DEC

INC	INC	DEC	DEC
Displayed ON/OFF setpoint increases 1 increment each time INC key is pressed.		Displayed ON/OFF setpoint decreases 1 increment each time DEC key is pressed.	

NUMERIC ENTRY

5	0	ENT
1st Digit shown in POS display	2 Digits shown in POS display	POS display blinks once to confirm setpoint change.
Changing setpoint to 50 degrees used as example.		

PULSE MODE

To change both setpoints of a pulse simultaneously.

PULSE	INC	OR	DEC
Pulse led lit	ON and OFF setpoints of ALL pulses increase/decrease 1 increment each time INC/DEC key is pressed.		

MULTI-PULSE MODE

To change all setpoints in the output channel simultaneously.

PULSE	PULSE	INC	OR	DEC
Pulse led lit	Pulse led blinking	ON and OFF setpoints of ALL pulses increase/decrease 1 increment each time INC/DEC key is pressed.		

CLEAR SETPOINTS

CLEAR 1 PULSE

To clear 1 pulse (1 pair of setpoints) on selected output channel.

Use numeric entry method (shown in CHANGE SETPOINTS above) to set OFF setpoint equal to ON setpoint value. Both setpoints will be erased.

CLEAR EXISTING SETPOINTS

To clear all setpoints on selected output channel.

ON	0	OFF	0	ENT
ON Led lit, POS blanks	0 shown in POS display	OFF Led lit, POS blanks	0 shown in POS display	POS display blinks and shows 0, ON and OFF LEDs are off.

Master Level Programming, Standard Controls: FCN 0

FCN 0 Programming at the Master Level

(Master Program Enable Input MUST be energized)

Function 0 allows specific features of the PLμS control to be programmed when the Master Program Enable input is energized. Standard Function 0 features include: Direction of Increasing Rotation, Scale Factor, Set-up Enable Code, Operator Enable Code, and Output Timing Resolution. Normally, the features controlled by Function 0 will be programmed only once for a specific application.

Optional Function 0 features are covered under "Options Programming," Section 5. They include: Sc (leading/trailing edge speed comp), ct (communication type), cS (communication Speed), cA (communication Address), and rU (RPM update frequency).

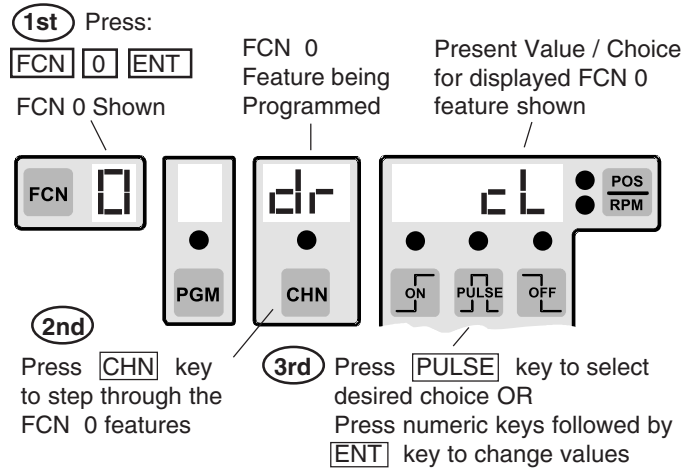

dr - Direction of Increasing Rotation

This allows the direction of increasing rotation of the position transducer (encoder / resolver) to be cL (clockwise) or ccL (counter clockwise) as required by the machine installation. This is normally set so the position value increases when the machine turns in its forward direction.

Resolver: cL or ccL as viewed from shaft end.

Encoder: cL or ccL as viewed from shaft end with cable entrance on the right.

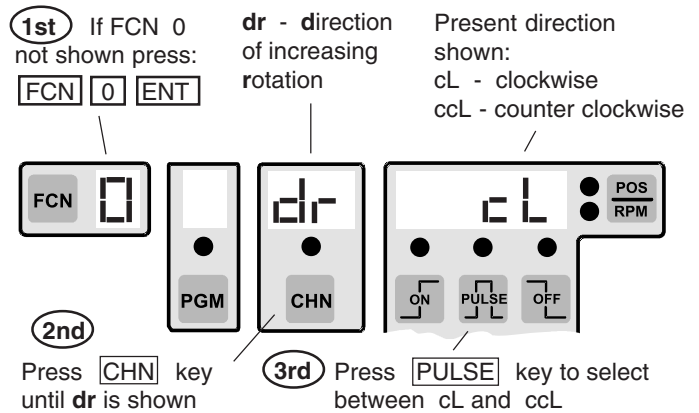

SF - Scale Factor (Resolver units only)

The Scale Factor is the number of increments each revolution of the resolver will be broken into. A Scale Factor of 360 (0-359) allows programming to be done in degrees. A Scale Factor of 1024 (0-1023) allows setpoint programming to be done at fine resolution (.35 degree increments).

Scale Factors range from 2-1024 on standard 5000 controls. Scale Factors range from 2-4096 on high resolution 5000 controls ("H" option).

Note: When Scale Factor is changed, all programmed setpoints are recalculated to convert them to the new Scale Factor. The keyboard will be inoperative during this time. Scale Factor value will blink once when calculation is completed.

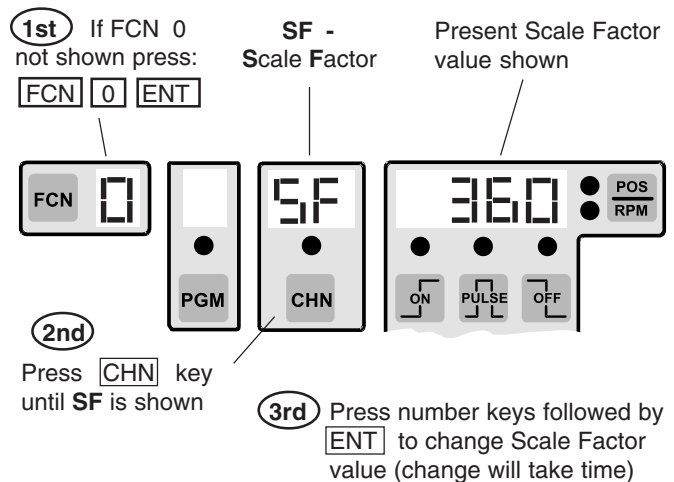

P1 & P2 Keyboard Enable Codes

P1 - Setup Enable Code Number

P2 - Operator Enable Code Number

These are the keyboard entry code numbers that will be used to access the Setup (P1) and Operator (P2) programming levels.

Any 1, 2, 3, or 4 digit value can be used for either P1 or P2.

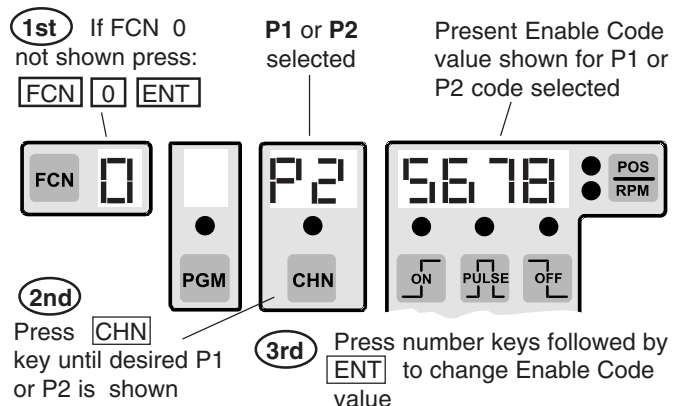

Master Level Programming, Standard Controls: FCN 0 (continued)

dd - Display Default (PS-51XX after 5/12/92)

Auto, Spd, or PoS can be selected for the display default by pressing the Pulse key while "dd" is displayed in function 0.

Auto - (Automatic) Display will automatically switch between POS and RPM when speed goes above and below the "tr" (toggle RPM) value programmed.

Spd - (Speed) On power up, the control will default to displaying RPM. The POS/RPM key can be used to switch between position and RPM display.

PoS - (Position) On power up, the control will default to displaying position. The POS/RPM key can be used to switch between position and RPM display.

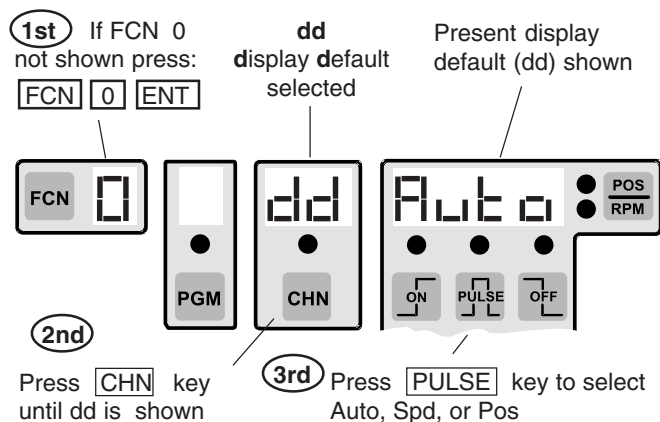

tr - Toggle RPM (All units after 5/12/92)

When the "Auto" mode is selected as the "dd" (display default), the value programmed in "tr" determines the speed where the display switches from position to RPM.

At speeds below "tr", position will be displayed and the "POS" LED will be lit.

At speed equal to or above "tr", RPM will be displayed and the "RPM" LED will be lit.

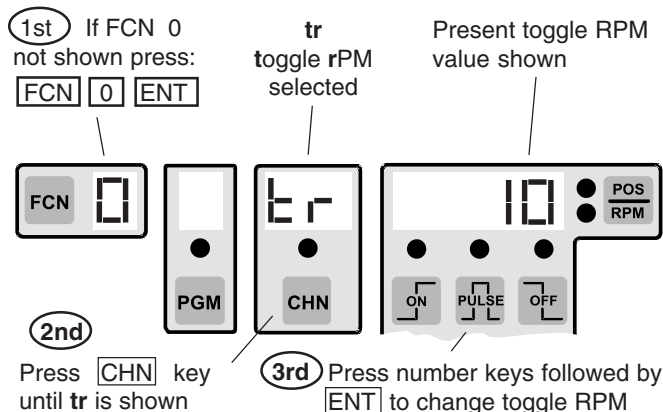

tb - Time Base Used for Output Timing

The timing resolution is selectable between 1 mSec and .5 mSec increments on 8, 9, and 16 output controls (24 and 48 output controls have a fixed 1 mSec tb and do not display tb in FCN 0). All timed outputs use the same time base. Timing accuracy of all timed outputs is -0, +1 tb increment. The number of outputs that can be timed is affected by the time base selected: (24 and 48 output systems can time up to 4 outputs)

1mSec tb - Up to 8 outputs can be timed (.001 - 9.999 Sec)

.5 mSec tb - Up to 4 outputs can be timed (.0005 - .9995 Sec)

Note: Adding too many timed outputs will cause an E9 programming error. The ".5" tb value will flash and cannot be selected if more than 4 timed outputs already exist in FCN 5.

Consult factory if more timed outputs are required.

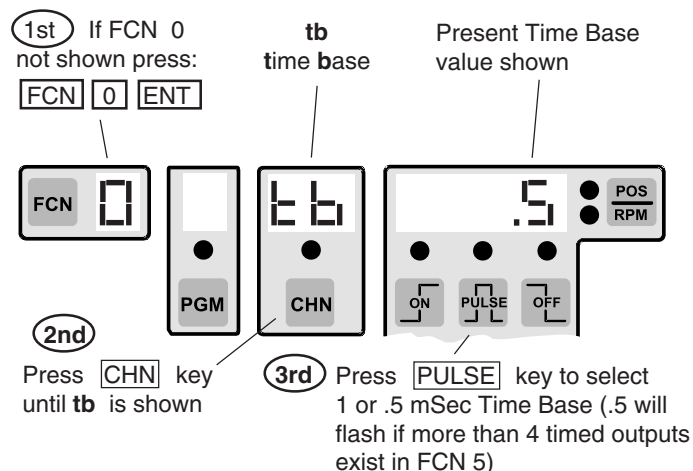

Enhanced Position/RPM Display Logic

All PS-51XX (Resolver) Series controls made after 5/12/92 include a feature that allows the user to program the display default to RPM, position, or automatically switch between RPM and position. Previous controls always defaulted to displaying RPM with the POS/RPM key, allowing manual selection of the item displayed. The POS/RPM key still

allows manual selection of the item displayed on the PS-5000 versions with the new display logic.

To control these display features, two items have been added to **FCN 0** programming : **dd** (display default) and **tr** (toggle RPM).

ct, cS, cA - Communication Parameters

ct - communication type: Specifies the type of communication port being used by the PL μ S control. It contains both an RS-232 and an RS-485 port. **RS-485 is the default setting.** Both of these ports share the DB-9 connector located at the top of the power supply section. The type of port being used on the PL μ S must match the type of port being used by the device communicating with the PL μ S.

cS - communication Speed: Specifies the baud rate (bits per second) that the PL μ S communication port will operate at. It must be set for the same baud rate as the device communicating with the PL μ S control. The choices are: 4800, 9600, 19200, and 38400 baud. **9600 is the default setting.**

cA - communication Address: Each control can have a unique communication address (0-255) because multiple controls can be wired to the same host device in a RS-485 network. This allows the host to send information to a specific control while the other controls will ignore the information. A PL μ S control will ignore incoming information if the address that information specifies does not match the communication address of the control.

NOTE: On units manufactured prior to date code 9740, the Communications Parameters (-C) option was required for communications features.

1st If FCN 0 not shown press: FCN 0 ENT

ct - comm type
cS - comm speed
cA - comm Address

Present value for selected comm item selected

2nd Press CHN key to choose ct, cS, or cA

3rd Press PULSE key to select desired option when ct or cS are selected

When cA is selected press number keys followed by ENT to change comm address

Comm Item	Choices
ct (port type)	RS-232, RS-485
cS (baud)	4800, 9600 , 19200, 38400
cA (comm add)	0-255; 1 is default

Default settings are shown in **bold face**.

rU - rPM Display Update Frequency

This function determines the frequency with which the display of RPM is updated.

- 1 Display updates RPM once per second
- 2 Display updates RPM twice per second
- 10 Display updates RPM ten times per second

NOTE: On units manufactured prior to date code 9740, the Expanded Operator Access (-E) option was required for rPM Display Update Frequency (rU).

Viewing / Changing Program Banks

1st If FCN 0 not shown press: FCN 0 ENT

rU
rPM Update selected

Present rPM Update frequency shown

2nd Press CHN key to select rU

3rd Press PULSE key to select desired update frequency.

FCN 6 - Operator Access

(Master Program Enable Input MUST be energized)

This function selects which features can be adjusted at the Operator access level. Step through them one at a time, and select On or Off according to whether or not the Operator should be able to adjust them.

Functions that are not Channel-Specific:

Sd—Speed Detection (FCN 1, Motion Setpoints and Analog Parameters if control has the “-A” option)

- on** Operator **can** adjust FCN 1 values
- oFF** Operator **cannot** adjust FCN 1 values

oF—Offset (FCN 2)

- on** Operator **can** adjust offset values
- oFF** Operator **cannot** adjust offset values

AP—Active Program (FCN 3)

- on** Operator **can** change program number
- oFF** Operator **cannot** change program number

Functions that are Channel-Specific:

The following functions—“SP,” “Sc,” and “to”—will be adjustable only for those channels turned “on” through “Output Channel Selection.”

Output Channel Selection

- on** Operator **can** adjust values in this channel
- oFF** Operator **cannot** adjust values in this channel

SP—Setpoints

- on** Operator **can** adjust setpoints
- oFF** Operator **cannot** adjust setpoints

Sc—Speed Compensation

 (FCN 4)

- on** Operator **can** adjust speed comp values
- oFF** Operator **cannot** adjust comp values

(Encoder-based controls with the “-E” option have Negative Speed Compensation capabilities, page 4-9.)

to—Timed Outputs

 (FCN 5)

- on** Operator **can** adjust timed outputs
- oFF** Operator **cannot** adjust timed outputs

NOTE: On units manufactured prior to date code 9740, operator access was limited to setpoints and timed output values, unless equipped with the Expanded Operator Access (-E) option.

Setting Output Channel Access

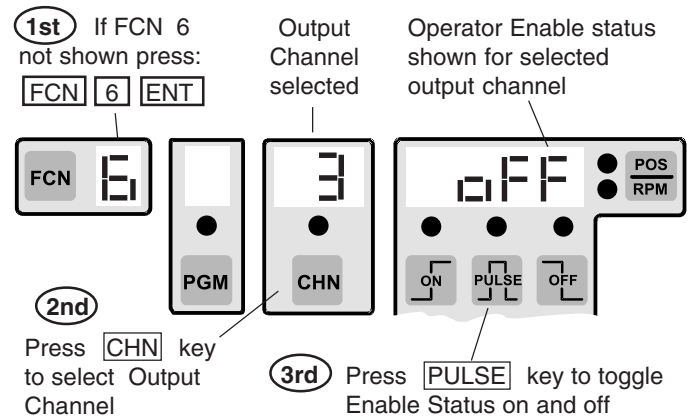

Setting Operator Accessible Functions

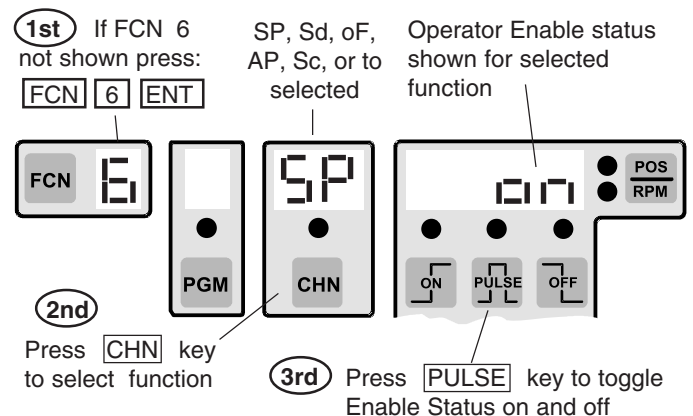

FCN 7 - Motion ANDing of Output Channels

(Master Program Enable Input MUST be energized)

This function selects which output channels will be ANDed with the Motion setpoints as programmed in **FCN 1**. ANDed outputs will be on during their programmed pulses only if the RPM is within the Motion setpoints. **In order for Motion ANDing to take affect, "On" and "Off" pulses must be programmed into the selected channel.**

An output channel can be turned into a motion detector by programming it to be "On" at 1, "Off" at 1, and then ANDing it with the Motion setpoints. Setting both points at 1 will turn the output on for a full 360°. By ANDing this output to the Motion setpoints, the output will be on constantly as long as the RPM is within the Motion setpoint range.

on - Output is disabled IF present RPM is not within Motion setpoints.

oFF - Output will cycle on and off at programmed position setpoints regardless of present RPM.

Note: Once programmed in a channel, this function will be present in that channel in all programs.

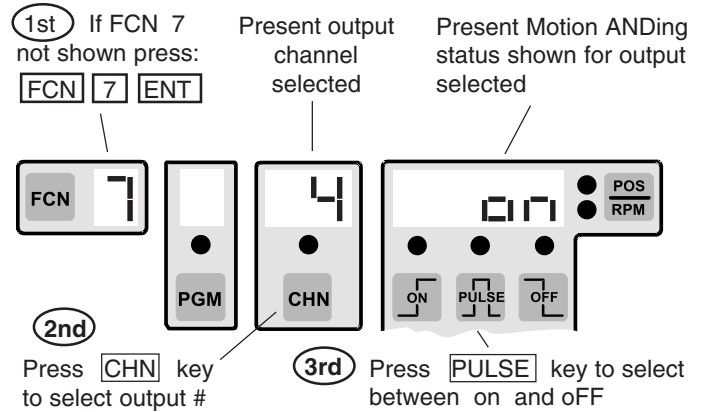

FCN 8 - Subdividing Outputs into Groups

(Master Program Enable Input MUST be Energized)

The outputs can be subdivided into as many as eight output groups. The number of output groups and the number of outputs in each group is determined by FCN 8.

Each output group can be set at a unique degree position through FCN 2 (CHN key selects Output group #).

When more than one output group exists the POS/RPM key will individually display each group's position by showing the group number above the CHN key while showing the current position next to the POS/RPM key.

When the number of outputs in each group is being assigned, all of the outputs must be accounted for. The last output group will automatically contain the outputs remaining after the number of outputs in the other groups is defined. The number of outputs in the last group automatically changes if the total number of outputs in the other groups is changed.

Each output group can have a dedicated enable input and be assigned to operated in any one of the Output Enable Modes. See FCN 9 for programming Enable Inputs and Modes.

See Output Grouping and Enable Modes section in the appendix of this manual for further information on output grouping.

Note: Once programmed in a channel, this function will be present in that channel in all programs.

Programming the Number of Output Groups

1st If FCN 8 not shown press: **FCN** **8** **ENT** Present number of Output Groups Present number of outputs

2nd Press **PGM** key (Number of Output Groups blinks)

3rd Press number key followed by **ENT** to change number of output groups (1-8)

Programming the Number of Outputs in Each Group

1st If FCN 8 not shown press: **FCN** **8** **ENT** Output Group # selected Present number of outputs in selected Output Group

2nd Press **CHN** key to select Output Group #

3rd Press number key followed by **ENT** to change number of outputs in selected group

FCN 9 - Enable Inputs and Enable Modes

(Master Program Enable Input MUST be Energized)

The number of Enable Inputs and the mode of operation for each output group with an Enable input is determined by FCN 9.

The 1st Enable Input (Output Group Enable 1) is located on the Logic terminal strip. If additional Enable Inputs are programmed, they will be input modules on the I/O rack, starting in order from the first module position (Group 2 Enable: module position 1; Group 3 Enable: module position 2; etc.). Each additional Enable Input reduces the available outputs by one, and automatically reduces the last output group by one output.

Brief Summary of Enable Modes:

- Mode 0 - Normal PLS operation, no Enable Input.
- Mode 1 - Enable Input causes Group position to re-zero.
- Mode 2 - Enable Input causes Group position to re-zero and enables outputs to cycle during next revolution.
- Mode 3 - Group outputs are on only if Enable Input is on.
- Mode 4 - Enable Input (within enable window) enables outputs to cycle during next revolution; group position does not re-zero.

Modes 1, 2, and 4 require enable windows to be programmed. Channel 91 is enable window for Group 1, channel 92 for Group 2 and etc. See Enable Modes in appendix for details.

Programming the Number of Enable Inputs

1st If FCN 9 not shown press: **FCN** **9** **ENT** Present number of Enable Inputs Present Enable Mode of Enable input

2nd Press **PGM** key (number of Enable Inputs blinks)

3rd Press number key followed by **ENT** to change number of Enable Inputs

Programming Output Enable Modes

1st If FCN 9 not shown press: **FCN** **9** **ENT** Enable Input # Selected Present Enable Mode of Selected Enable Input

2nd Press **CHN** key to select Enable Input

3rd Press number key followed by **ENT** to change Enable Mode of Enable Input selected

Setup Level Programming, Standard Controls: FCN 1, FCN 2, FCN 3

FCN 1 - Motion Setpoints

(Setup or Master program enable must be active)

Motion logic is active whenever the present RPM is between or equal to the Low and High motion setpoints. Motion logic can be selectively ANDed with outputs (FCN 7) and also controls the "Motion Detection Output" on the Logic terminal strip. The Motion LED on the keyboard is lit when the Motion logic is on.

Lo - Low RPM setpoint for motion

Hi - High RPM setpoint for motion

Ao, Ah (analog) covered in Options Programming section.

Note: Once programmed in a channel (FCN 7) this function will be present in that channel in all programs.

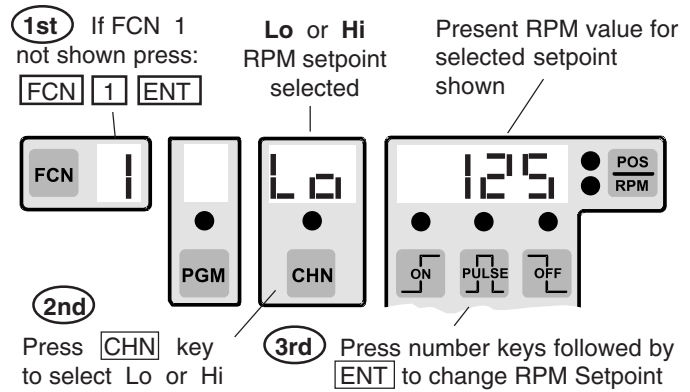

FCN 2 - Offset

(Setup or Master program enable must be active)

The Offset function allows the controller position to be set to match the position of the machine. This eliminates the need to mechanically adjust the position of the resolver/encoder shaft to match the machine position.

To set the Offset, simply stop the machine in a known position and enter that known machine position value into FCN 2. The position display on the control will match the machine position at all times when the Offset is correctly set.

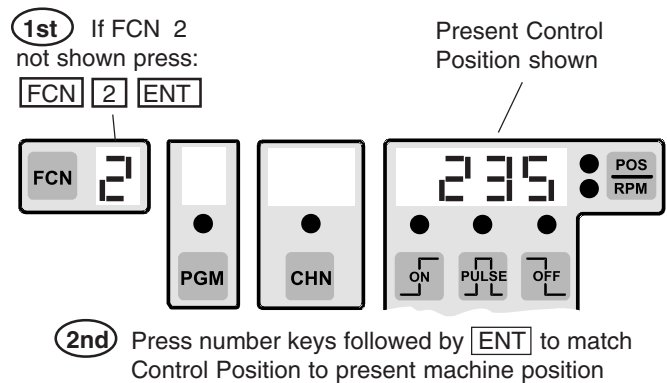

FCN 3 - Program Number

(Setup or Master program enable must be active)

The Active Program is the program (machine setup) which is currently controlling the outputs. The total number of programs available are subdivided into groups of eight which are called Program Banks. Each Program Bank contains eight individual programs.

When all Program Select inputs are off the keyboard selected Active Program will be active.

The number of Program Banks available varies with the number of outputs the control has as follows:

- 8-16 outputs - 8 Banks - 64 Programs total
- 24 outputs - 6 Banks - 48 Programs total
- 48 outputs - 3 Banks - 24 Programs total

A convenient Program number (Pn) feature allows the desired program number (1-64) to be viewed or entered directly without having to enter the corresponding values into the Program bank (Pb) and Active Program (AP) parameters. This is the method described below under "Viewing or Changing Program Numbers from Keyboard."

Normal Display of Program Number

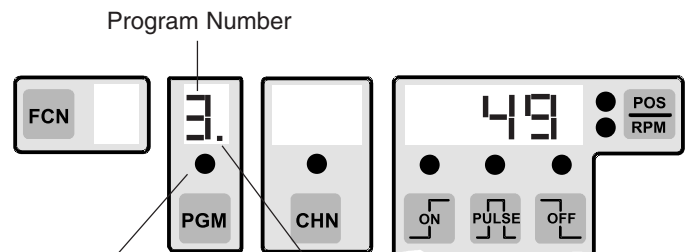

If LED is lit, the program number shown is active, regardless of which bank it is in.
If LED is off, the program number shown is not active.

If decimal point is **present**, the active bank is **not** Bank 1; use FCN3, Pb to determine bank #.
If decimal point is **absent**, active bank is Bank 1.

To determine active program and bank number, or to switch programs, use FCN 3, next page.

NOTE: On units manufactured prior to date code 9740, active program was limited to Program Bank (Pb) and Active Program (AP), unless equipped with Expanded Operator Access (-E) option.

Setup Level Programming, Standard Controls: FCN 1, FCN 2, FCN 3

If the hardware program select inputs are going to be used to select programs (they can be driven from a PLC or selector switch), it may be necessary to program the Program bank (Pb) and Active Program (AP) from the keyboard. Follow the instructions given below under “Hardware Selection of Program Number.”

Viewing or Changing Active Program Number from Keyboard

Use the Program number (Pn) feature of FCN 3 to see the active program number or select any program directly by entering the corresponding number from 1-64. The corresponding “Pb” and “AP” values will automatically be calculated and selected. It will not be necessary to calculate or program “Pb” or “AP”, but they can be viewed to verify that their values correspond to the selected program number.

Pn— Program number (1-64)

Pb— Program bank (1-8); 8 banks of 8 programs each

AP— Active Program (1-8); active program within bank

Example:

If Program number (Pn) 34 is selected, “Pb” will equal five (5th bank of eight programs) and “AP” will equal two (2nd program within this bank).

DO NOT enter values into “Pb” or “AP” if the keyboard program selection is being used. Simply program “Pn” to the desired program number from 1-64.

Hardware Selection of Program Number

The hardware program select inputs override the keyboard programmed Active Program (AP) value when any one or combination of the inputs is energized. When the hardware inputs are used to select the Active Program (AP), insure that “AP” is set equal to one.

The hardware select inputs only affect the current “AP” value that is controlling the outputs. The “Pb” is not affected by the select inputs and has to be changed from the keyboard if more than eight programs are used.

To summarize, hardware select inputs can select which of the eight programs in the current program bank is controlling the outputs, but changing the program bank number must be done through the keyboard by programming “Pb.”

Note: Active Program and Program Bank can be changed through the serial communication port also.

Viewing/Changing Program Number

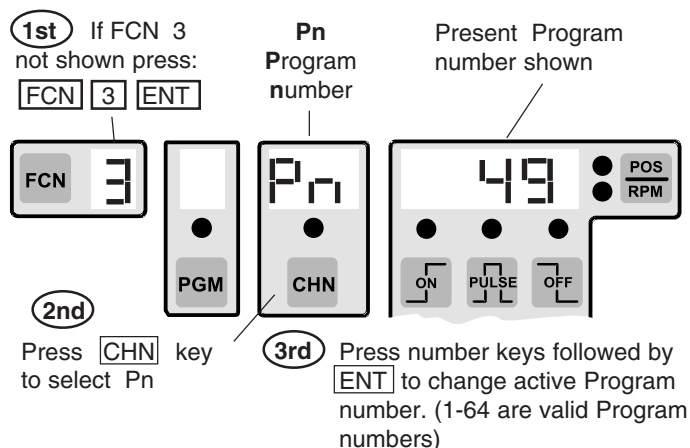

Viewing/Changing the Active Program

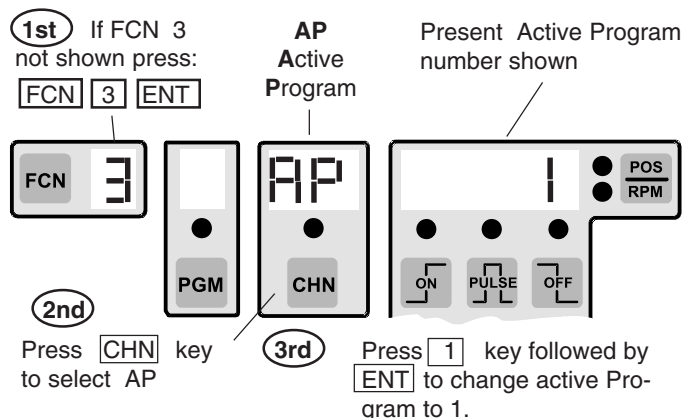

Viewing/Changing Program Banks

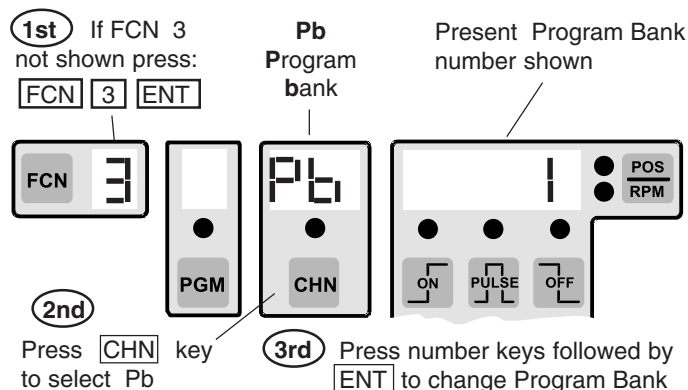

FCN 4 - Speed Compensation

(Setup or Master program enable must be active)

Speed Compensation is the ability of the control to automatically advance an output's setpoints as the machine speeds up, thus compensating for the response of the device being controlled. Each output can be individually compensated by a unique amount. This allows all output devices to be properly compensated, even though their responses may vary widely.

Standard speed compensation advances and retards both the on and off edges of output pulses by the same amount, proportional to the present machine speed.

Leading/Trailing Edge speed compensation, available on controllers with the "L" option, allows a different amount of compensation to be set for the leading and trailing output edges in each channel. See page 5-1 for details.

Gray Code speed compensation is available on controllers with the "G" option. See page 5-3 for details.

Speed compensation is set in units of **Degrees/1000 RPM**, regardless of the scale factor being used. If the response of the output device is known, the amount of Speed Comp required can be calculated:

$$\text{Speed Comp (Deg/1000 RPM)} = 6 \times \text{response (in mSec)}$$

$$\text{EX: } 20 \text{ mSec response: } 6 \times 20 = 120 \text{ (Deg/1000 RPM)}$$

Program the output for the correct on and off setpoints at zero speed and then program speed comp value.

If the device response is not known, program output for the correct on and off setpoints at zero machine speed. Program

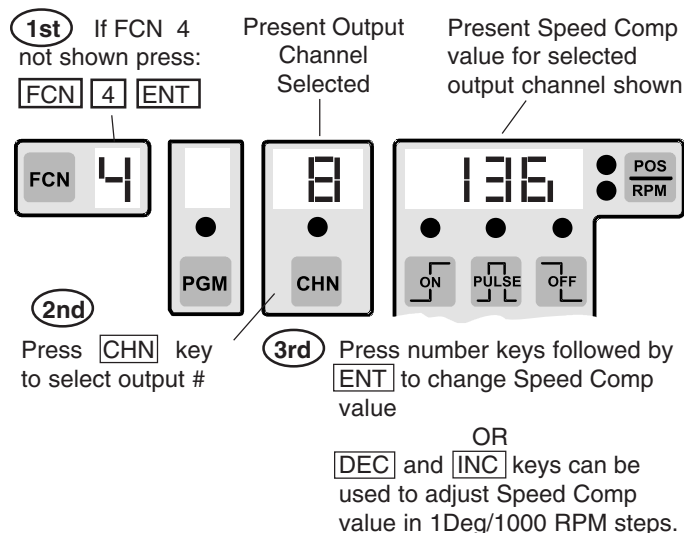

the output with an estimated speed comp value based on six times the estimated response in mSec (mSec = .001 Sec). Run the machine at a typical speed and adjust Speed Comp until the output is properly synchronized to the machine.

Note: 1 Degree/1000 RPM resolution allows Speed Comp to be adjusted very accurately. Because the adjustment is so fine, it may be necessary to make larger changes to the Speed Comp value to see a change in machine performance. A change of 6 degrees/1000 RPM is needed to make a 1 mSec difference to the device being controlled.

FCN 4 - Negative Speed Compensation (Input Gating)

(Setup or Master program enable must be active)

This feature is included on the following units which were built after 5-19-92, date codes 9222 or greater. The date code is printed beneath the model code on the label on the back of the controller:

- All PS-51XX (Resolver) units
- All PS-50XX (Encoder) units date code 9740 or newer, and units with "E" option prior to 9740.

Negative Speed Compensation causes an output channel to lag its programmed machine position by the specified degrees/1000 RPM. It is used when an input sensor is being gated by the corresponding output channel into another system (PLC, registration control, etc.) Since most sensors have very fast response times, negative speed comp is needed only where the sensor is slow to respond, or the machine speeds are high and sensor timing is critical.

Example: Assume a product sensor requires 5 msec to respond, and an output channel provides a reference window to a PLC. The PLC will trigger an action only if the sensor indicates a product is present during the output channel's reference window. At 1000 RPM, the resolver will rotate (5 msec x 6), or 30 degrees during the sensor response time. If the reference window isn't also delayed by 30 degrees per 1000 RPM, the sensor signal may miss the reference window.

Negative Speed Compensation is programmed in Deg/1000 RPM. If the response of the input device is known, the amount of Negative Speed Compensation needed can be calculated:

$$\text{Speed Comp (Deg/1000 RPM)} = 6 \times \text{response (in mSec)}$$

$$\text{EX: } 10 \text{ mSec response } -6 \times 10 = -60 \text{ (Deg/1000 RPM)}$$

Because the PLuS control has individual speed compensation for each output channel, it is possible to have some outputs compensated positively while others are set for Negative Speed Compensation.

(continued next page)

Note: Once programmed in a channel, this function will be present in that channel in all programs.

FCN 4 - Negative Speed Comp (continued)

In order to activate Negative Speed Compensation, the corresponding channel must first be set equal to "0" speed compensation in FCN 4, and then decremented by pressing the DEC key. Speed compensation for that channel will then stay in the negative mode until it is set back to "0" speed compensation.

Whenever Negative Speed Compensation is programmed, the speed compensation value shown in the position display will have a minus ("-") sign in the left-most digit.

Note: To restore Positive Speed Compensation set the compensation value back to 0. Then key in desired amount of Positive Speed Compensation.

To Program Negative Speed Comp:

1st If FCN 4 not shown press: **FCN 4 ENT**

Present Output Channel Selected

Present Speed Comp value for selected output channel shown

2nd Press **CHN** key to select output #

3rd Press 0 key followed by **ENT** to change Speed Comp value to 0

Then... FCN 4 shown

Present Output Channel Selected

Present Speed Comp value for selected output channel shown

4th Press **DEC** key to change Speed Comp value from 0 to -1

Then... FCN 4 shown

Present Output Channel Selected

Present Speed Comp value for selected output channel shown

5th Press number keys followed by **ENT** to program desired Negative Speed Comp value

or

DEC and **INC** keys can be used to adjust Speed Comp Value in 1 Deg/1000 RPM steps.

FCN 5 - Timed Outputs

(Setup or Master program enable must be active)

Outputs can be turned off after a specified time duration, instead of staying on until the off position setpoint is reached. Any output can be timed, and each timed output can specify a unique time dwell. This is appropriate for devices which require a specific output time, regardless of machine speed.

Timed outputs are programmed like standard outputs with "on" and "off" position setpoints specified. A timed output will turn on at the specified "on" position setpoint, and will turn off after the specified time delay or when the "off" position setpoint is reached, whichever occurs first. **If the time out value is set to zero, the output will not be timed.**

If an E9 tdE error message occurs, too many timed outputs exist for the current time base selected. Either reduce the number of timed outputs or change the time base being used. See tb section of FCN 0 programming (page 4-5) for details.

To calculate output timing, use the following relationships:

$$\begin{aligned} \text{RPM} \times 360 &= \text{Degrees per Minute} \\ \text{Degrees per Minute} \div 60 &= \text{Degrees per Second} \\ \text{Degrees per Second} \div 1000 &= \text{Degrees per msec} \end{aligned}$$

Therefore: $\text{RPM} \times .006 = \text{Degrees per msec}$

Example: Suppose a timing dwell of 20 msec has been established. At 1000 RPM, the transducer will rotate:

$$1000 \times .006, \text{ or } 6^\circ \text{ per msec}$$

During the 20 msec dwell time, the transducer will rotate 120° at 1000 RPM.

1st If FCN 5 not shown press: **FCN 5 ENT**

Present Output Channel Selected

Time-out value (mSec) for selected output (0 = No Time-out) Decimal is automatically inserted for 0.5mSec Time Base.

2nd Press **CHN** key to select output #

3rd Press number keys followed by **ENT** to change Time-out value

or

DEC and **INC** keys can be used to adjust Time-out value in Time Base increments

Note: Once programmed in a channel, this function will be present in that channel in all programs.

Leading / Trailing Edge Speed Compensation: Option “-L”

FCN 0 Sc - Type of Speed Compensation

(units with “L” option only)

onE - Standard Speed Compensation: One value of speed compensation is programmed for each output channel. Both the leading and trailing edges of output pulses are compensated by the same amount. Controls that do not have the “L” option operate in this manner. A unique amount of speed comp can be programmed for each output channel.

both - Leading and Trailing Edge Speed Compensation:

A different amount of speed compensation can be programmed for the Leading and Trailing pulse edges of each output channel. This allows proper compensation for output devices with different turn on and turn off responses.

Selecting the Type of Speed Compensation

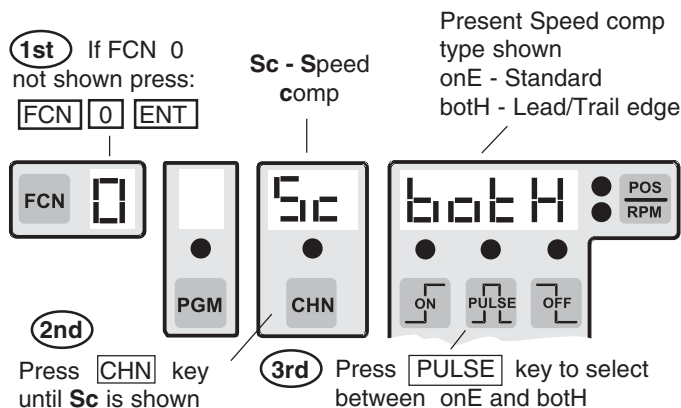

FCN 4 - Leading/Trailing Edge Speed Compensation

(Setup or Master program enable must be active)

Speed Compensation is the ability of the control to automatically advance an output's setpoints as the machine speeds up, thus compensating for the response of the device being controlled. Each output can be individually compensated by a unique amount. This allows all output devices to be properly compensated, even though their responses may vary widely.

When the control is set for leading/trailing edge speed comp (FCN 0, Sc=both), two speed compensation values may be programmed for each output channel - one for the leading pulse edges (turn on), one for the trailing pulse edges (turn off). The amount of speed compensation needed is determined in the same manner used for standard speed compensation, but two values will be needed for each output channel being compensated.

Speed compensation is set in units of Degrees/1000 RPM, regardless of the scale factor being used. If leading edge and/or trailing edge responses of output device are known, the amount of Speed Comp required can be calculated:

Speed Comp (Deg/1000 RPM) = 6 x response (in mSec)

EX: 20 mSec response; 6 x 20 = 120 (Deg/1000 RPM)

Program the output for the correct on and off setpoints at zero speed and then program speed comp values for the leading and trailing edges.

If the device response is not known, program output for the correct on and off setpoints at zero machine speed. Program the output with estimated speed comp values based on six times the estimated response in mSec (mSec = .001 Sec). Run machine at a typical speed and adjust leading and trailing edge speed comp values until output is properly synchronized to the machine.

Programming the Leading Edge Speed Comp Value

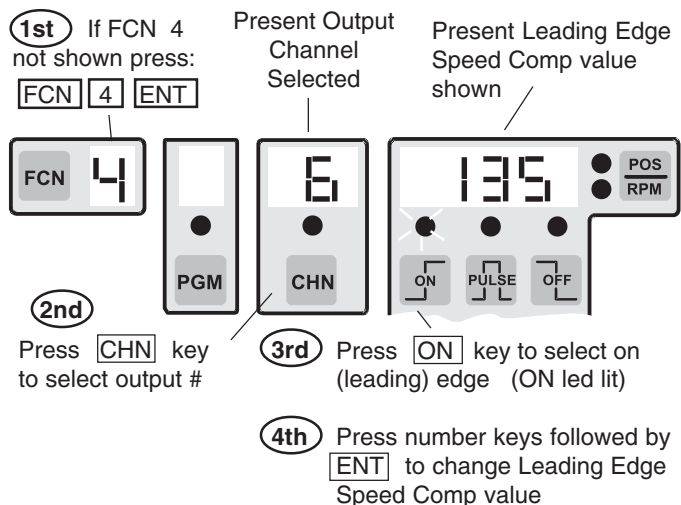

Programming the Trailing Edge Speed Comp Value

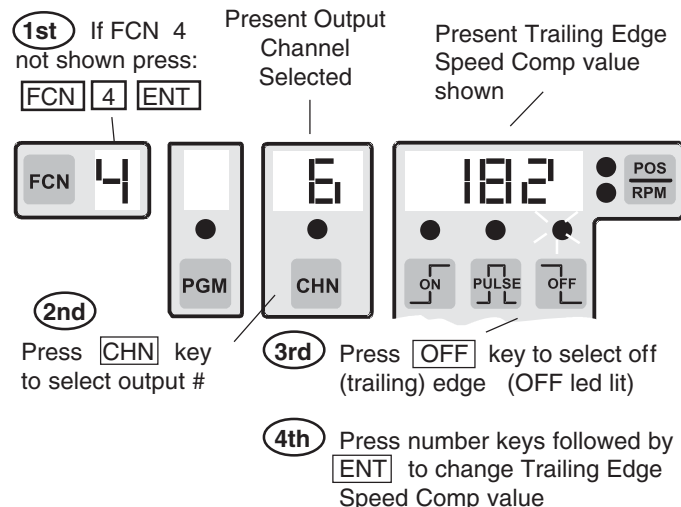

Note: Once programmed in a channel, this function will be present in that channel in all programs.

Analog Output: Option “-A”

FCN 1 Ao, Ah - Analog Output Signal

(Units with "A" option only)

The analog option allows PLμS controls to output an analog signal that is linearly proportional to the current machine RPM. Analog output modules are available with either 0-10 VDC or 4-20 mA output. The two parameters that define the operation of the Analog output are the Offset and the High RPM (speed at which full scale signal occurs).

Ao - Analog offset: The Analog offset is the analog signal level that will be output when the machine is at zero RPM. This allows the minimum analog signal to be greater than zero volts or 4 mA, which is required in many applications. The offset is programmed in terms of the number of 12 bit (4096) increments that the minimum signal level should be. Calculate the Offset value to be programmed as follows:

For 20 mA: $((\text{Min Sig} - 4) / (16)) \times 4096$

EX: 5 mA Min Sig Ao = $((5-4)/(16)) \times 4096 = 256$

For 10 VDC: $(\text{Min Sig} / 10) \times 4096$

EX: 2 VDC Min Sig Ao = $(2 / 10) \times 4096 = 819$

Ah - Analog high RPM: The Analog high RPM is the lowest speed at which full scale analog output will occur. It is programmed in whole RPM.

EX: Need 5 mA output at zero RPM and 20 mA output at 1200 RPM. Ao = 256 (mA example above) and Ah = 1200 RPM.

Programming the Analog Offset

1st If FCN 1 not shown press: **FCN** **1** **ENT**

Ao - Analog offset Present Analog offset in 1/4096ths of full scale signal

2nd Press **CHN** key until **Ao** is shown

3rd Press number keys followed by **ENT** key to change Analog offset value

Programming the Analog Full Scale Signal RPM

1st If FCN 1 not shown press: **FCN** **1** **ENT**

Ah - Analog high (RPM) Present RPM for full scale analog signal output

2nd Press **CHN** key until **Ah** is shown

3rd Press number keys followed by **ENT** key to change Analog high RPM value

Outputs Based On Direction of Rotation: Option “-D”

In standard PLμS controllers without the “-D” option, outputs will turn ON/OFF based on resolver position, regardless of which direction the resolver is turning. With the “-D” option, outputs can be based on the direction the resolver is rotating. Outputs can be set individually to be based on direction.

Direction ANDing: To choose which channels are to be based on direction, select Alternate Function 5. This is accomplished by pressing the FCN key and POS/RPM key simultaneously, then pressing 5, then pressing ENTER. The number 1 will appear above the channel key (CHN). OFF will appear in the display on the right, next to the POS/RPM key.

Toggle through each channel by pressing the CHN key. Toggle the feature between OFF, increment direction ANDing (INC), and ON decrement (DEC) direction ANDing by pressing the PULSE key. The factory default will be OFF for all channels.

Direction Hysteresis: Direction hysteresis is used to specify how far in one direction the resolver must rotate before a change in direction ANDing occurs and affects the output ON/OFF status. This level is adjustable so that vibration in the machine will not cause outputs to switch. Select Alternate Function 6 to enter the hysteresis value (1 to 9999 scale factor units). Note that the resolver must move twice the hysteresis value in the opposite direction before the change in direction ANDing occurs. The default is 2.

Use **CHN** key to toggle between OFF, INC, DEC

Hysteresis value

Speed Compensated Gray Code Output: Option “-G”

Gray Code Position Output - (Units with the "G" Option)

Plus Controls with the Gray Code output option output eight bit Gray Code position information on the last eight outputs. The position output takes into account the control's Offset value. Therefore, the Gray Code position matches the position shown on the control's position display. The Gray Code position output can be Speed Compensated as a group of outputs as shown below.

The Ladder Diagram shown on the right will convert the eight bit Gray Code output signal (G0-G7) from the PLS control to a binary number (B0-B7) during each scan of the PLC. Because only one bit changes state per Gray Code increment, the decoding process is error free and does not require the use of latching or handshaking circuitry. The value of the Binary result will always be in the range of zero to 255 because the eight bit Gray Code divides each revolution into 256 uniform increments. Ladder rungs which follow the conversion can compare the rotary position value to known positions for control of machine devices that must operate at specific positions within the overall machine cycle. The rotary position of the machine cycle can also be used to gate input sensors and shift register functions.

Gray Code Conversion Ladder

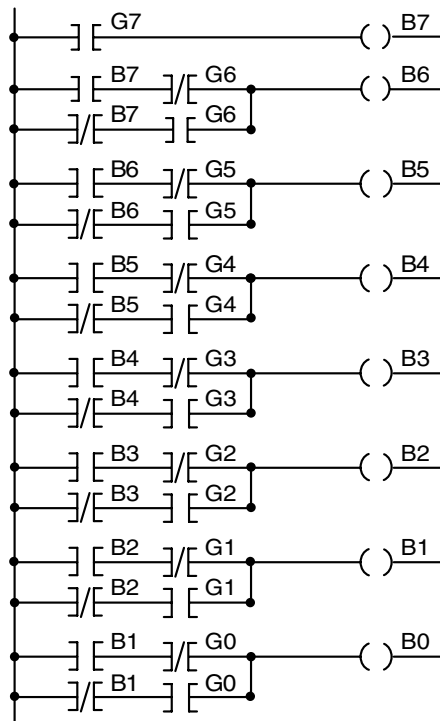

Converting Gray Code to Binary involves a sequence of “Exclusive OR” operations. It is simple to program this same conversion logic in other programming languages besides ladder logic. In addition to decoding the rotary position of the encoder, controls with arithmetic capability can be programmed to offset position if required.

G0 - G7 = Gray Code Input Bits from PLS control to PLC
 B0 - B7 = Binary Equivalent of Gray Code Position from PLS control
 G0 = LSB, G7 = MSB

16 outputs	CHN 9-16	9 = LSB, 16 = MSB
24 outputs	CHN 17-24	17 = LSB, 24 = MSB
48 outputs	CHN 41-48	41 = LSB, 48 = MSB

FCN 4 - Gray Code Speed Compensation (Setup or Master program enable must be active)

Speed Compensation is the ability of the control to automatically advance an output's setpoints as the machine speeds up. The Gray Code position output can be Speed Compensated as a group by entering a speed comp value into the first channel of the Gray Code outputs (Least Significant Bit). All of the Gray Code output channels will be compensated by this same amount. The channels to enter Gray Code speed comp into are as follows:

16 output system:	output channel 9 (9 = LSB)
24 output system:	output channel 17 (17 = LSB)
48 output system:	output channel 41 (41 = LSB)

Speed compensation is set in Degrees/1000 RPM, regardless of the scale factor being used. If the response of the device is known, the amount of Speed Comp required can be calculated:

Speed Comp (Deg/1000 RPM) = 6 x response (in mSec)
 EX: 20 mSec response: 6 x 20 = 120 (Deg/1000 RPM)

1st If FCN 4 not shown press: **FCN** **4** **ENT**

1st Gray Code Output Channel Selected

Present Speed Comp value for Gray Code shown

2nd Press **CHN** key to select 1st Gray Code output # (no other Gray Code outputs can be selected)

3rd Press number keys followed by **ENT** to change Speed Comp value

OR **DEC** and **INC** keys can be used to adjust Speed Comp value in 1Deg/1000 RPM steps.

Note: 1 Degree/1000 RPM resolution allows Speed Comp to be adjusted very accurately. However, it may be necessary to make larger changes to the Speed Comp value to see a change in machine performance. A change of 6 degrees/1000 RPM is needed to make a 1 mSec difference to the device being controlled.

Extra Program Storage: Option “-F”

PS-5000 Series PL μ S controls containing the “F” option can store approximately four times as many output pulses (approximately 4500 pulses) in permanent memory as standard PS-5000 Series controls. The exact number of pulses that can be stored will vary between different models and features included.

An “F” option control can store as many as 992 different setpoint programs. Unlike other PL μ S controls, a special “Pn” (program number) feature included in “F” controls allows direct access to any program by entering its 3-digit value. Also, the current active program number is displayed during normal operation as shown below.

Number of Pulses/Programs Available

The actual number of different programs that can be entered is determined by the total number of pulses that can be stored (approx. 4500) and the number of pulses needed for each program.

For example, if 14 outputs are being used and each output has 1 pulse per machine cycle, the total number of programs that could be stored would be:

$$\frac{4500 \text{ total pulses (approx)}}{14 \text{ pulses per program}} = 321 \text{ programs}$$

Special Alternate Functions have been included in the “F” option to report the total number of pulses that can be stored, and how many are currently programmed. See page A-16 for directions on accessing alternate functions.

ALT FCN 1010 displays exact total number of pulses available.

ALT FCN 1011 displays number of pulses presently programmed.

Pulses Remaining = ALT FCN 1010 minus ALT FCN 1011

!! WARNING !!

PL μ S controls continuously calculate a checksum value which represents all of the programmed contents in the permanent memory. **The control power must remain on a minimum of five seconds after any programming change is made to insure that the new checksum has been calculated.**

If power is turned off before the checksum is calculated, the control will have to check the validity of all programmed contents on the next power-up. This will take approximately 18-20 minutes. The control will not be able to run the machine during this time.

Active Program Number Displays

The current active program will always be displayed while RPM is displayed as shown below.

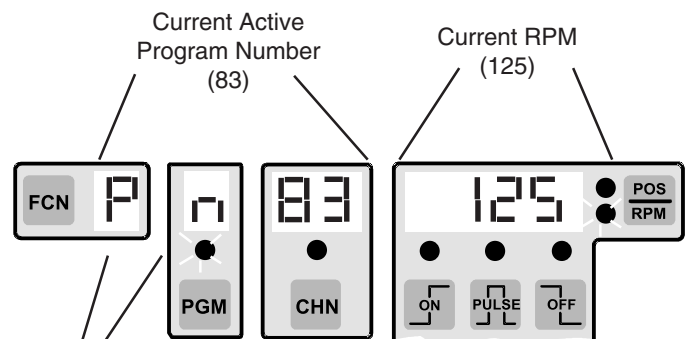

NOTE: Pn shown for 2 digit Program Numbers

The current active program will be displayed while position (POS) is displayed (shown below) if neither of the following two conditions exist:

1. An output channel is selected.
2. The control is a PS-5XX4 with more than 1 output group established.

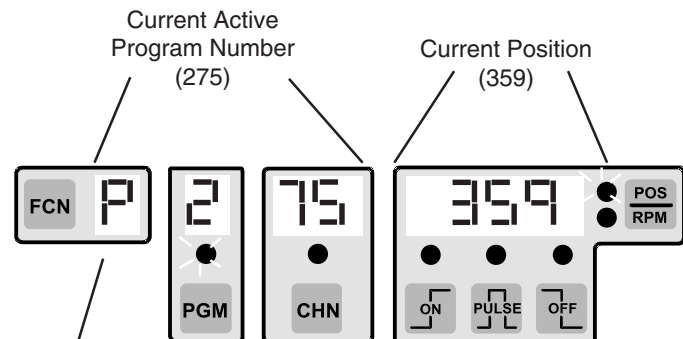

NOTE: P shown for 3 digit Program Numbers

(Option “-F” continued next page)

FCN 3 - Program Number Changes

The “F” option can store up to 992 unique programs in memory. These program numbers can be created and accessed in random order.

A convenient Program number (Pn) feature allows the desired program number (1-992) to be entered directly without having to enter the corresponding values into the Program bank (Pb) and Active Program (AP) parameters. This is the method described below under “Changing Program Numbers from Keyboard.”

If the hardware program select inputs are going to be used (they can be driven from a PLC or selector switch) to select programs, it may be necessary to program the Program bank (Pb) and Active Program (AP) from the keyboard. Follow the instructions given below under “Hardware Selection of Program Number.”

Changing Active Program Number from Keyboard

Use the Program number (Pn) feature of FCN 3 to select any program directly by entering the corresponding number from 1-992. The corresponding “Pb” and “AP” values will automatically be calculated and selected. It will not be necessary to calculate or program “Pb” or “AP”, but they can be viewed to verify that their values correspond to the selected program number.

Pn— Program number (1-992)

Pb— Program bank (1-124); 124 banks of eight programs each

AP— Active Program (1-8); active program within bank

Example:

If Program number (Pn) 94 is selected, “Pb” will equal 12 (12th bank of eight programs) and “AP” will equal six (6th program within this bank).

DO NOT enter values into “Pb” or “AP” if the keyboard program selection is being used. Simply program “Pn” to the desired program number from 1-992.

Hardware Selection of Program Number

The hardware program select inputs override the keyboard programmed Active Program (AP) value when any one or combination of the inputs is energized. When the hardware inputs are used to select the Active Program (AP), insure that “AP” is set equal to one.

The hardware select inputs affect only the current “AP” value that is controlling the outputs. The “Pb” is not affected by the select inputs and has to be changed from the keyboard if more than 8 programs are used.

Note: Active Program and Program Bank can be changed through the serial communication port also.

Viewing / Changing Program Number

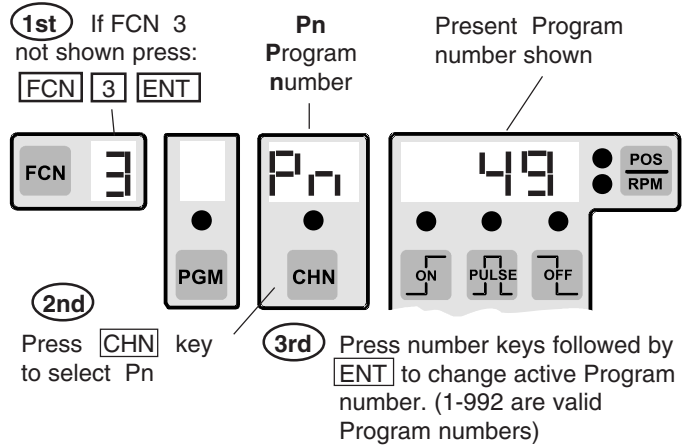

Viewing / Changing the Active Program

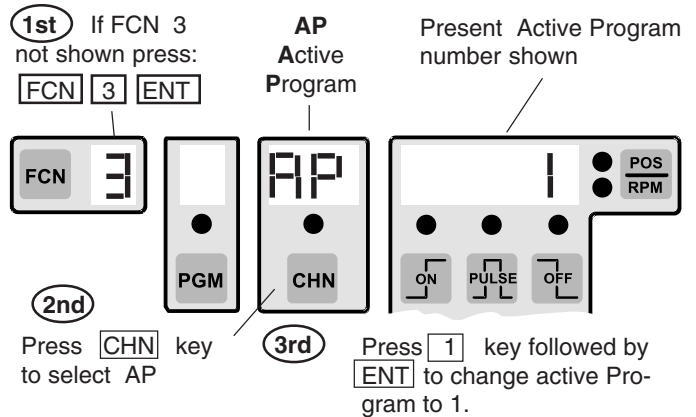

Viewing / Changing Program Banks

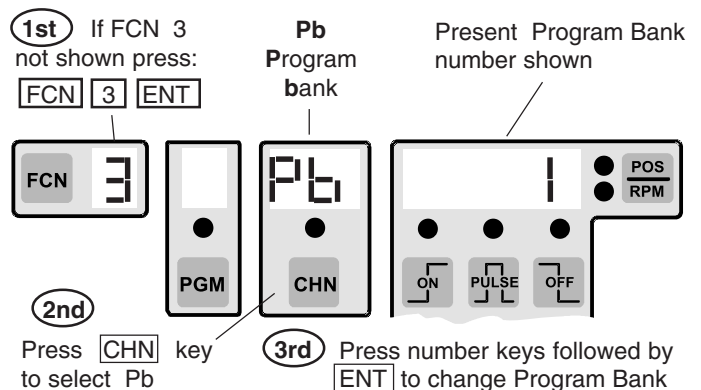

(Option “-F” continued next page)

Viewing/Editing Inactive Program

Any inactive program can be viewed or edited from the PLuS keyboard while the current active program controls the machine.

Pressing the PGM key will select any inactive program for viewing or editing. Press the number keys of the desired program number followed by ENT to select the desired inactive program. This program number will be shown in the setpoint display area to the right of “Pn” in the channel display (the PGM LED will be off while inactive programs are selected).

Specify which channel, within the selected program, will be viewed/edited by pressing the CHN key followed by the desired channel number and ENT (the Pn display will be replaced by the selected channel number and corresponding output setpoint information).

To exit the selected inactive program and return to normal active program displays press the POS/RPM key.

Select Inactive Program Number to be Viewed/Edited

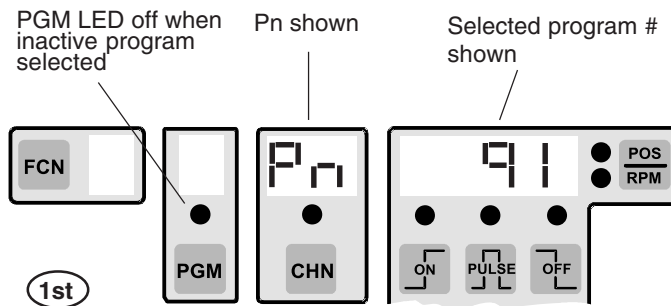

1st Press **PGM** key

2nd Press number keys followed by **ENT** to select desired inactive program # (1-992 are valid program numbers)

Select Channel to be Viewed/Edited

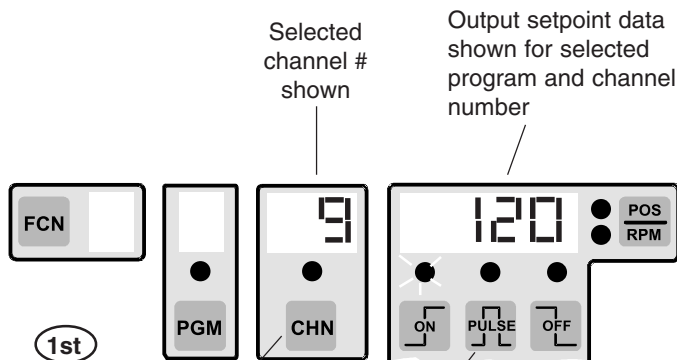

1st Press **CHN** key and number keys of desired channel

2nd Use **VIEW**, **ON**, **OFF**, **PULSE**, **INC**, **DEC** and number keys to View/Edit output setpoint data

Phase Mark Registration: Option “-P”

The “P” option (phase mark registration) dedicates two PLuS outputs—Channels 14 & 15—as registration inspection windows for input to registration controls or PLCs. In many cases, this can replace mechanically adjusted registration sensor mechanisms at far less cost, without sacrificing ease of adjustment. Registration adjustments can be made through keyboard commands or dedicated increase and decrease hardware inputs (push buttons, etc.).

Note: Substitute channels 7 & 8 for 14 & 15 on 9 output units.

Output channels 14 and 15 are programmed individually so they have the output duration and phase relationship required by the registration control system. Once both channels are programmed, their setpoints can be simultaneously moved to any machine position without altering their duration or their phase relationship to each other. This greatly simplifies registration setup and adjustment. Outputs 14 and 15 can be used interchangeably as “too soon” and “too late” signals, and their pulse durations do not have to be equal.

Registration Window Examples and Adjustment Methods

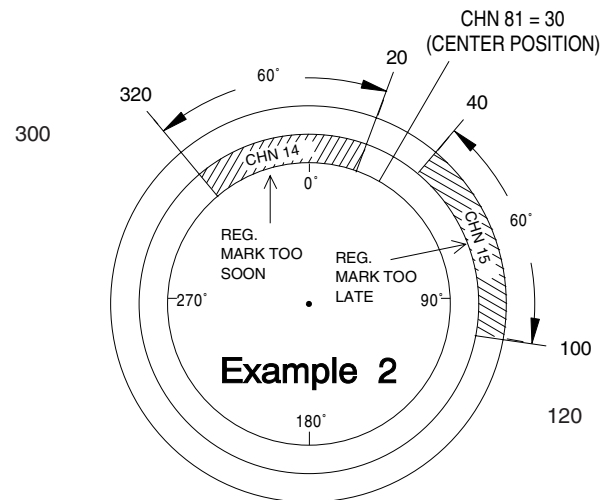
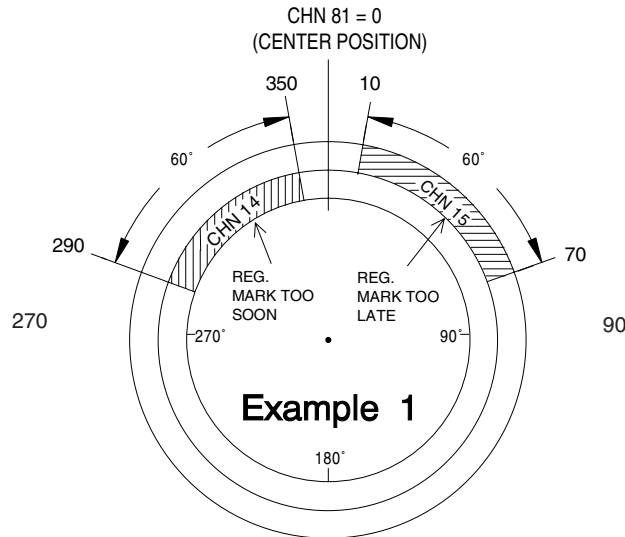

Example 1 illustrates the following:

CHN 14 - ON @ 290 OFF @ 350
CHN 15 - ON @ 10 OFF @ 70
CENTER POSITION = 0

If the registration mark is sensed while CHN 14 is on, the registration control will determine that the material should be retarded. If the registration mark is sensed while CHN 15 is on, the registration control will determine that the material should be advanced. If the registration mark is sensed between the CHN 14 and CHN 15 on pulses, the registration is within tolerance and no adjustment is needed.

Example 2 illustrates the following:

CHN 14 - ON @ 320 OFF @ 20
CHN 15 - ON @ 40 OFF @ 100
CENTER POSITION = 30

Although the channel 14 and 15 values in example 2 seem very different from example 1, they are actually the same pulses phase shifted so that the center between them is now 30 instead of 0. To get from example 1 to example 2, it was NOT necessary to go into channels 14 or 15 to make changes, only the center position had to be changed. The pulses in outputs 14 and 15 are automatically adjusted to correspond to the new center position.

The following methods change the center position:

Decrease/Increase Inputs (logic terminals 3 & 4)—Energize the Decrease or Increase input to shift the registration pulses and center position by one increment in the corresponding direction (remote push buttons).

Center Input (logic terminal 5)—Energize the Center Input on the logic input strip to change the registration center position to the current machine position.

Channel 81—Select CHN 81 and the existing center value will be displayed. Press INC / DEC keys or key in a new center value and press ENT to change it.

Channel 80 - Select CHN 80 and press ENT to change the registration center position to the current machine position (machine was at 30 in example 2).

To accomplish registration control, it is necessary to wire channel 14 and 15 outputs, and the registration mark sensor, as inputs to a registration control system or PLC. Exact wiring is determined by the control system being used.

Some registration control systems will use the “off” portions of channels 14 and 15 as the registration windows. The “P” option can automatically handle these applications as well. Detailed explanation of this “Off” logic is on page 5-13.

Phase Mark Registration: Option “-P” (continued)

Logic Terminal Strip (see pgs. 2-1 thru 2-3 for location)

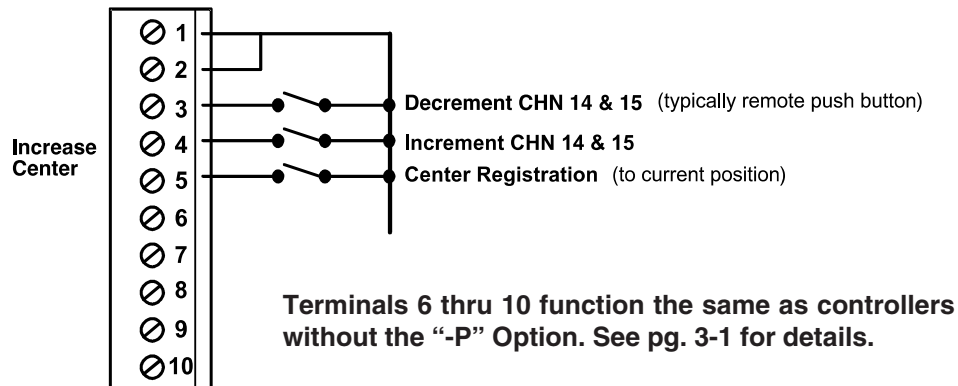

Input Information

Registration Input Terminals

Input terminals 3, 4, and 5 have special registration functions on “-P” option controls. It is not possible to use these terminals to change programs from hardware inputs, as on 5000 Series controllers, without the “-P” option. Keyboard program selection (FCN 3) or serial communication must be used to change programs on “-P” option controls.

Terminals 3, 4, and 5 are always active. To program CHN 80 or CHN 81 through the keyboard, the Master, Set-Up, or Operator access levels must be activated through the logic terminal strip inputs or the keyboard enable codes.

General Logic Input Information

The logic inputs are energized by a current sinking path to Logic Common. They can be switched to common through the use of mechanical switches, relays, or NPN transistor outputs. The inputs are held at approximately 12 VDC and conduct 4 mA of current to common when energized.

Note: Substitute channels 7 & 8 for 14 & 15 on 9 output units.

Decrease Input (Terminal 3; normally Program Select 1)

The decrease input is a one-shot that causes the programmed setpoints in both channels 14 and 15 to be decremented one step each time the input is energized (center decreases one step). The control will display the new CHN 14 “on” value for two seconds after the input is energized.

Increase Input (Terminal 4; normally Program Select 2)

The increase input is a one-shot that causes the programmed setpoints in both channels 14 and 15 to be incremented one step each time the input is energized (center increases one step). The control will display the new CHN 14 “on” value for two seconds after the input is energized.

Center Input (Terminal 5; normally Program Select 3)

The center input is a one-shot that causes the setpoints in channels 14 and 15 to automatically change so the current machine position becomes the registration center position. “SEt” will be displayed for two seconds after the input is energized (this function is equivalent to accessing CHN 80 or setting CHN 81 = current machine position).

Center Input will not function if outputs 14 and 15 do not each have a pulse programmed.

(Option “-P” continued next page)

Phase Mark Registration: Option “-P” (continued)

CHN 80 - Auto-Center Registration

The gap between the output 14 and 15 pulses (registration OK area) can be automatically centered around the current machine position by accessing CHN 80. This allows the correct registration phase to be set up in a single operation.

1. Move the machine (jog or move by hand) to the exact position where the registration mark should be detected by the sensor.
2. Access CHN 80 to center the current registration windows around the current machine position (machine should be stopped).
3. Display will show "SET" after CHN 80 is entered to confirm that the centering operation has been accomplished.

Energizing the hardware Center Input causes the control to perform the same operation as CHN 80.

CHN 80 or the hardware Center Input will not function if outputs 14 and 15 do not each have a pulse programmed.

Note: Substitute channels 7 & 8 for 14 & 15 on 9 output units.

Jog machine to position where Registration mark should be sensed.

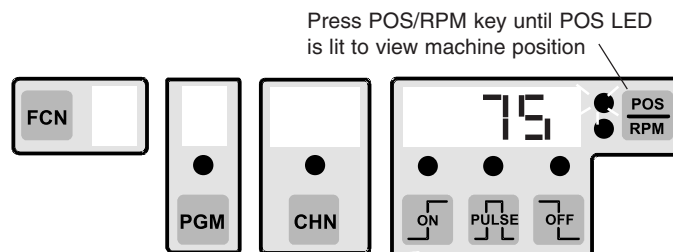

Access CHN 80 to center registration around current machine position.

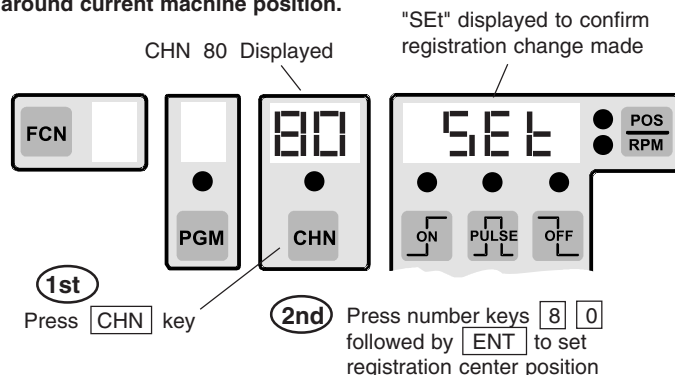

CHN 81 - Display Adjust Registration Center

The center of the gap between the output 14 and 15 pulses (registration OK area) can be monitored and/or changed through CHN 81. Each time CHN 81 is accessed, its value is calculated from the current output 14 and 15 pulses. Therefore, CHN 81 can be a unique value within each program and is not a global value. For this reason, CHN 81 is **not** part of the PLSNET ASCII file used to store, edit and load the control's programmed contents through serial communication.

Changes can be made by entering the new center position through the keyboard, eliminating the need to move the machine to a specific position.

1. Access CHN 81 to view the current registration center position value.
2. Key in the new desired center position and press “Enter” to change it; or Press “INC/DEC” keys to make one step changes to the center position. Each time the Increase or Decrease inputs are energized, the display will show the new registration center position (CHN 81) for 2 seconds. If no change is desired, press “POS/RPM” to return to the Position or RPM display, or access other programming operations in the normal manner.

CHN 81 will not function if outputs 14 and 15 do not each have a pulse programmed.

Access CHN 81 to view / change current registration center position

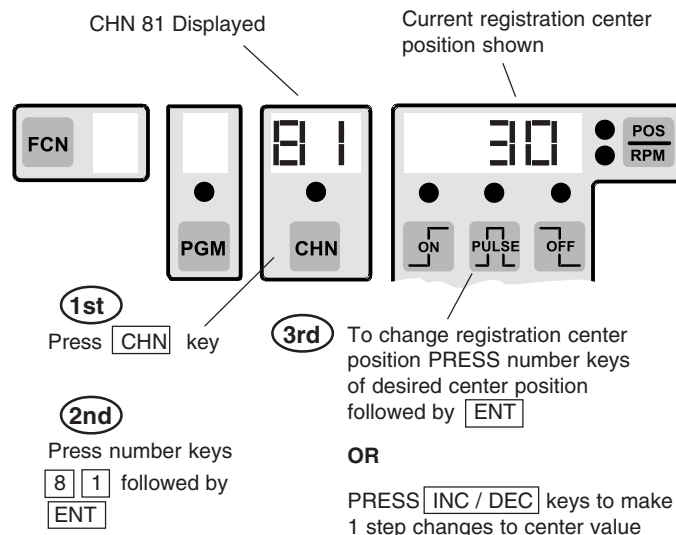

(Option “-P” continued next page)

Automatic Reversal of Centering Logic

Some registration control systems use the “Off” portion of the input signals as the registration correction windows. In these cases, outputs 14 and 15 will each be “On” for most of the revolution, and off only during the registration correction windows. The “P” option logic automatically handles these situations.

The control assumes that “Off” registration logic is being

used whenever the “On” duration of output 14 is greater than 180 degrees. In this “Off” logic mode, the registration centering functions (CHN 80, CHN 81 and the Center Input) are based on the smaller gap between the “Off” portions of outputs 14 and 15, rather than the smaller gap between the “On” portions. Examples 3 and 4 below are the “Off” logic equivalents of Examples 1 and 2 on page 5-5.

“OFF” Logic Registration Examples

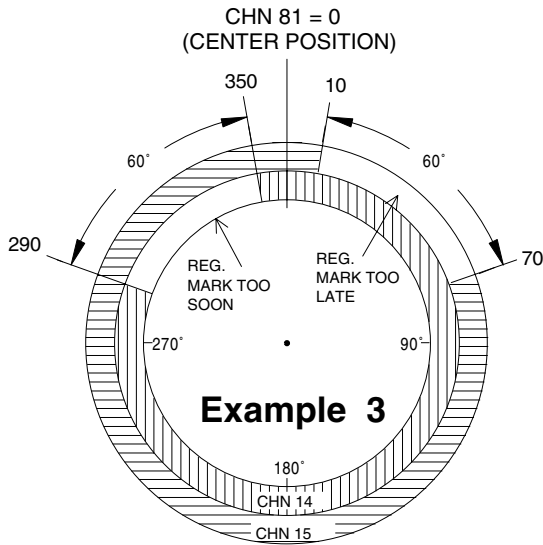

CHN 14 - ON @ 350 OFF @ 290
 CHN 15 - ON @ 70 OFF @ 10
 CENTER POSITION = 0

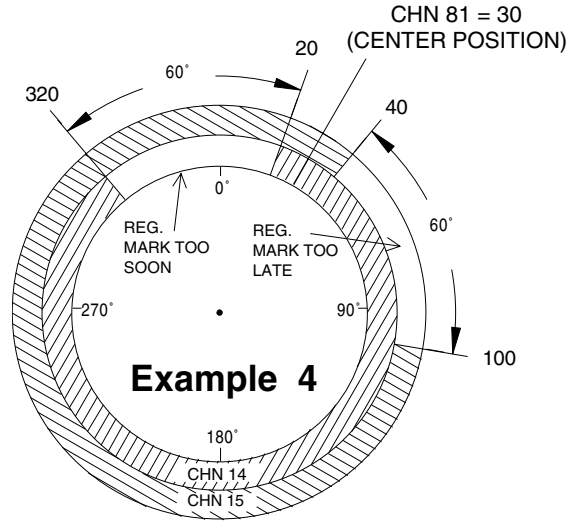

CHN 14 - ON @ 20 OFF @ 320
 CHN 15 - ON @ 100 OFF @ 40
 CENTER POSITION = 30

In examples 3 and 4, output 14 has an on duration greater than 180. Therefore, the control automatically assumes “off” logic is being used. All center calculations and adjustments use the smaller gap between where outputs 14 and 15 are off.

The output 14 and 15 values in example 4 are the result of the values in example 3 being shifted by 30. CHN 80, CHN 81, and the center input can be used to adjust the center value as before. The pulses programmed in outputs 14 and 15 are automatically adjusted to correspond to the new center position.

Note: Substitute channels 7 & 8 for 14 & 15 on 9 output units.

Advantages of Grouping Outputs

PS-5XX4 controls can be subdivided into as many as eight different output groups. Each group can have dedicated enable input. There are two primary reasons to group outputs:

1. Outputs may be grouped together so they can be enabled if a specific input condition is met, and disabled if that input condition is not met.

A typical example of this situation is gluing. Usually a photo eye or other device senses the presence of product immediately before gluing should occur. If the product is not present, the corresponding glue outputs should not cycle. The controller can accomplish this type of logic in Modes 2, 3 or 4, if these glue outputs are grouped together and the corresponding sensor is connected to the input which controls this group of outputs.

2. The outputs are grouped together because they must maintain a constant phase relationship with each other while being able to vary their group phase relationship to the other outputs.

A typical example of this situation is a web converting process where individual items are being made from a web of material. Often times the phase relationship between different sections of the machine changes due to stretch and other variables. The outputs at each section must stay in phase with that section, not the position transducer. If the outputs for a given section are grouped, the phase of the group can be adjusted, rather than having to individually adjust each of the outputs in the group. The adjustments can be made manually from the keyboard or automatically by an external signal from a sensor or other control device.

A comprehensive understanding of the operating modes is required to realize the potential advantages of output grouping (pages A-3 to A-11 give detailed explanations of each of the five modes). The fact that each group can be in any of the five modes and operates independent of the other groups makes grouping a powerful tool in many applications.

Grouping Outputs and Establishing Modes

The programming of FCN 8 determines how many output groups are created and how many outputs will be in each group. FCN 9 programming determines how many inputs are available and the mode in which each input (and the corresponding group of outputs) will operate. The "Output Group Enable 1" terminal on the logic terminal strip (p. 3-1) is always the input for Group 1. Additional inputs require input modules, located in the initial positions of the I/O rack. These module positions are no longer available for outputs and the number of outputs available is reduced accordingly.

Outputs are assigned to the groups in sequential order. Therefore, Group 1 output(s) will start with the first available output (after the input modules on rack) and include the specified number of outputs. Group 2 will begin with the next output and run sequentially until its specified number of outputs is reached. This process continues for up to eight groups. However, the last group will automatically include all of the outputs that are left. Therefore, the number of outputs in the last group is affected by the number of outputs in the other groups and the number of additional inputs established.

How to Program Output Grouping and Modes

1. Access FCN 8 and program the PGM display for the desired number of output groups. (see p. 4-9)
2. While in FCN 8 assign the desired number of outputs to each group except the last group (it will always contain all of the remaining outputs - this number will change if additional inputs are specified).
3. Access FCN 9 and program the PGM display for the desired number of inputs (see p. 4-9). Only one input per output group is allowed. (Inputs do not have to be allocated for groups operating in Mode 0, if these groups come after the groups that are using other modes.)
4. While in FCN 9 specify the mode of operation for each of the inputs established.
5. Program the appropriate input windows (CHN 91 - Group 1, CHN 92 - Group 2, etc.) for groups that are operating in Modes 1, 2 or 4. These windows must be individually programmed in each program used.

Note: Detailed information on the operating characteristics of modes and the function of the input windows is itemized for each mode on pages A-3 to A-11.

Logic Input Compared to Input Modules

The input for output Group 1 is on the logic terminal strip of the controller. Additional inputs require the use of input modules on the I/O rack. The characteristics of each of these input types is as follows:

Logic Terminal Input - Accepts a sinking signal only. Does not give any indication of input status by the input strip or on the keyboard displays. Response time is approximately 10 msec. Does not consume an output position on the I/O rack.

Module Input (module located on I/O rack) - AC and DC input modules available. Typical DC response is 2-3 msec and DC modules can be wired for sinking or sourcing signals. An LED (in or next to module) shows input status.

Input modules are easier to interface electrically, and provide LED indication of their on/off status. It can be advantageous not to use the logic terminal input by operating Group 1 in Mode 0 to control outputs not associated with input signals.

Note: Once programmed in a channel, this function will be present in that channel in all programs.

Output Grouping and Modes I/O Configuration Examples

Example #1: On a nine I/O 5X24, establish three groups of outputs with four outputs in Group 1, two outputs in Group 2 and the remaining outputs (1) in Group 3. Group 2 and Group 3 both have a photo eye input associated with them and will operate in Mode 4.

Program FCN 8 as follows:

PGM	CHN	POS	
3	01	4	(Group 1 = 4 outputs, modules 3-6)
3	02	2	(Group 2 = 2 outputs, modules 7-8)
3	03	1	(Group 3 = 1 output, module 9)

The “3” in the PGM display represents the number of groups, the CHN display is the group number and the POS display shows the number of outputs in the corresponding group. (p. 4-7 illustrates FCN 8 programming).

Program FCN 9 as follows:

PGM	CHN	POS	
3	E1	0	(Group 1 in Mode 0, term strip input)
3	E2	4	(Group 2 in Mode 4, module 1 input)
3	E3	4	(Group 3 in Mode 4, module 2 input)

The “3” in the PGM display represents the number of inputs being allocated, the CHN display shows which Enable input is being programmed, and the POS display shows the mode selected for the corresponding input. (p. 4-7 illustrates FCN 9 programming)

Example #1: I/O Rack Configuration

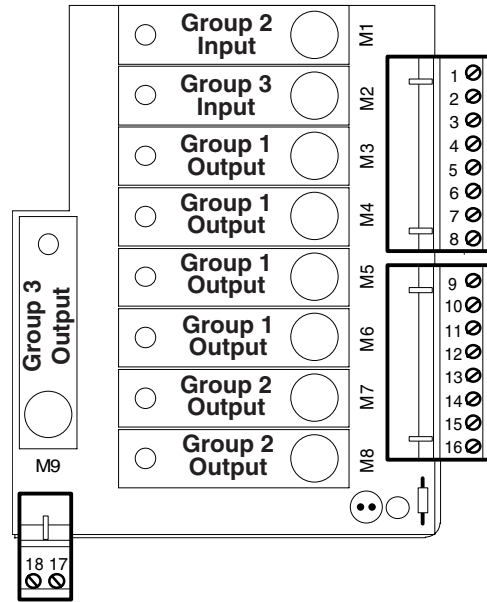

Note: Group 1 Input on Controller Logic Terminal Strip (not used in this example because Group 1 is in Mode 0)

Example #2: On a 16 I/O 5XX4 controller, establish four groups of outputs with six outputs in Group 1, two outputs in Group 2, three outputs in Group 3, and the remaining outputs (two) in Group 4. Each group requires an input signal and the groups will operate in Modes 1-4, respectively.

Program FCN 8 as follows:

PGM	CHN	POS	
4	01	6	(Group 1=6 outputs, modules 4-9)
4	02	2	(Group 2=2 outputs, modules 10-11)
4	03	3	(Group 3=3 outputs, modules 12-14)
4	04	2	(Group 4=2 outputs, modules 15-16)

The “4” in the PGM display represents the number of groups, the CHN display is the group number and the POS display shows the number of outputs in the corresponding group. (p. 4-7 illustrates FCN 8 programming)

Program FCN 9 as follows:

PGM	CHN	POS	
4	E1	1	(Group 1 in Mode 1, term strip input)
4	E2	2	(Group 2 in Mode 2, module 1 input)
4	E3	3	(Group 3 in Mode 3, module 2 input)
4	E4	4	(Group 4 in Mode 4, module 3 input)

The “4” in the PGM display represents the number of inputs being allocated, the CHN display shows which Enable input is being programmed, and the POS display shows the mode selected for the corresponding input. (p. 4-7 illustrates FCN 9 programming)

Example #2: I/O Rack Configuration

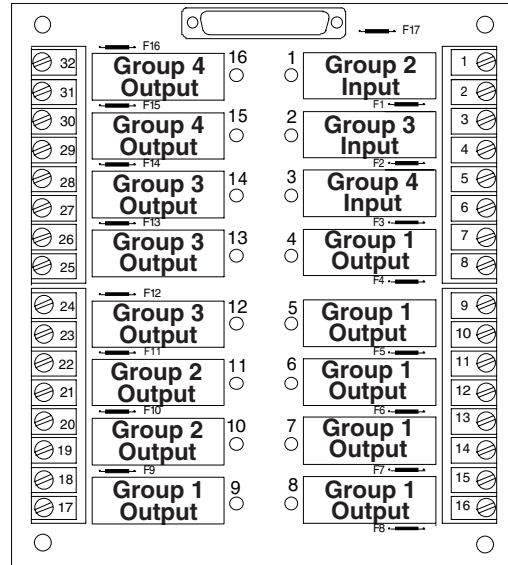

Note: Group 1 Input on Controller Logic Terminal Strip

Introduction to Modes

The use of modes allows PS-5XX4 controls to perform output logic which goes beyond simple cam outputs. There are five different modes (modes 0-4) which can be assigned to output groups. Each mode has unique operating characteristic which can be matched to the logic requirements of the corresponding groups. In many situations, using mode logic can eliminate the need for external logic (PLC or discrete circuits) in series with the PS-5XX4 outputs.

Each output group can be operated in the most appropriate mode, regardless of which mode(s) other groups are operating in. In many applications, more than one mode will be used to satisfy the control requirements of different machine sections. Following are brief descriptions of the modes:

Mode 0 - Outputs always enabled, like a simple cam switch, and the group position can only be adjusted manually through the keyboard. This mode is appropriate for output signals which must occur at the exact same position in every machine cycle.

Mode 1 - Resets group position to zero when the group enable input signal occurs. Outputs are always active. This mode is appropriate for phasing output groups from sensors or other devices which signal a mechanical reference position. Can also be used in applications where some machine sections run multiple cycles per resolver revolution.

Mode 2 - Disables group outputs until the group enable input signal occurs. When the input occurs, the group position immediately resets to the preset value and the outputs are allowed to cycle during the next machine cycle. This mode is useful for applications where products may not be evenly spaced and the group outputs must only cycle when a product has been sensed.

Mode 3 - Only enables outputs to cycle when group enable input is on. If the input is off, all of the outputs in the corresponding group will be off, regardless of position. Use this mode where the presence of a maintained signal indicates that it is OK for the group outputs to be active.

Mode 4 - Enables outputs to cycle if the group enable input signal turned on during a designated portion (window) of the cycle. Outputs will be disabled at the end of the cycle until the input signal turns on again during the window portion of another cycle. Use this mode to check presence and correct position of a product before enabling the output group for this machine cycle.

Example Applications that Use Modes

Web Converting Machines - Disposable diapers, medical pads, office folders, etc. Phase relationships between machine sections can be adjusted manually using Mode 0 or automatically using Mode 1.

Cartoners / Case Packers - Vacuum, material handling, loading, and other functions are usually controlled in Mode 0. Gluing functions are typically controlled in Mode 4 to prevent glue from being dispensed when containers are not present.

Vertical Form/Fill/Seal Machines - Package material handling output functions are controlled in Mode 0, while pump or fill functions are handled in Mode 1 to automatically correct for mechanical phase changes made between these two sections of the machine (this allows one resolver to do a job that would otherwise require two resolvers).

Machines with Multiple Cycle Ratios - Some machines have different sections that run at different cycle ratios per overall machine cycle. For example, one portion of a machine may complete several cycles while another section makes only one cycle. By using Mode 1 or 2, it is possible to have some output groups cycling multiple times while other groups cycle only once.

Details of Mode 0 - Standard Cam Operation

An output group operating in Mode 0 will turn on the outputs every time the group position is within the programmed position setpoints. The outputs are always enabled. No input logic is used with Mode 0; the corresponding input is ignored. The position of the output group can only be adjusted through the keyboard using FCN 2. The group position information will be stored in permanent memory and proper group position will be restored each time the control is powered on.

Use Mode 0 whenever the corresponding outputs are required to operate during every cycle of the machine.

How to Program Mode 0 Operation

1. Program FCN 8 and 9 to correctly establish the output grouping and modes required for this machine application (insure that Mode 0 is selected for this group).
2. Check that this group has the desired position relationship to the machine position. Program FCN 2 to adjust it.
3. Program output setpoints to cycle the outputs on and off at the desired output group positions.

No other programming is required for Mode 0.

Note: Mode 0 logic never disables the outputs, however, Motion ANDing (FCN 7) can disable outputs that are operating in Mode 0.

Mode 1 Operation

Details of Mode 1 - Alter Position from Input Signal

An output group operating in Mode 1 will have its outputs enabled at all times. What makes it different from simple cam logic is its ability to alter its position relationship to the machine based on an external input signal. The start (leading edge) of an input signal will instantly cause the group's position to be reset to zero. The outputs will immediately update in accordance with the zero position and continue cycling from that point.

The input signal acts in a momentary manner, therefore it doesn't matter how long the input remains energized. The reset to zero operation will occur when the leading edge of the input signal occurs. However, once the reset occurs, the control disarms the input and ignores it until it becomes re-armed. A programmed window determines where the input will become re-armed (re-arming the input is similar to cocking a gun; once it is re-armed it can fire at any position).

The input window is programmed in the same manner that output pulses are programmed and is referenced to the corresponding group position. Channel 91 is the window for Group 1, Channel 92 for Group 2, and so on up to 98. The position where the window is programmed determines if the input is re-armed right away or ignored until a specified number of degrees of travel occur. The window can be reached from either direction of travel. Therefore, the on edge of the window determines how much forward travel is needed to reach the window, and the off edge determines how much reverse travel is needed.

The position reference that is established by input signals does not get stored in the control's permanent memory. Therefore, when the control powers up, a Mode 1 group will assume the last offset programmed through FCN 2. On power up, the input is armed and the first signal received will cause the position to immediately reset to zero.

Example Application: Control sections of a machine that vary in phase relationship

This illustration shows a single PLS control and resolver controlling three "Adjustable Phase" sections of a converting machine. The rotary position of the electrical output signals can be manually set/adjusted from the keyboard or automatically adjusted by sensors. This keeps the electrical control signals properly synchronized to the mechanical devices in each section when phase adjustments are made. One resolver provides the position information needed for all sections of the machine, regardless of their phase relationship.

Note: All gear drives are 1:1 ratio.

How to Program Mode 1 Operation

1. Program FCN 8 and FCN 9 to correctly establish the output grouping and modes required for this machine application (insure that Mode 1 is selected for this group).
2. Program the input window (CHN 9X) to start where the group enable input should be re-armed when the machine is moving in a forward direction and to end where the input should be re-armed if the machine is moving in reverse. If the input should always be armed, program CHN 9X to start on 1 and end one increment before zero.

Note: The group input window (CHN 9X) and the group output position setpoints must be programmed individually for each of the controller programs used. Different programs can have different values as required.

If the output group position fails to reset when input signals occur, insure that an input window (CHN 9X) is programmed and that the input is wired to the control correctly.

Mode 1 Example Application

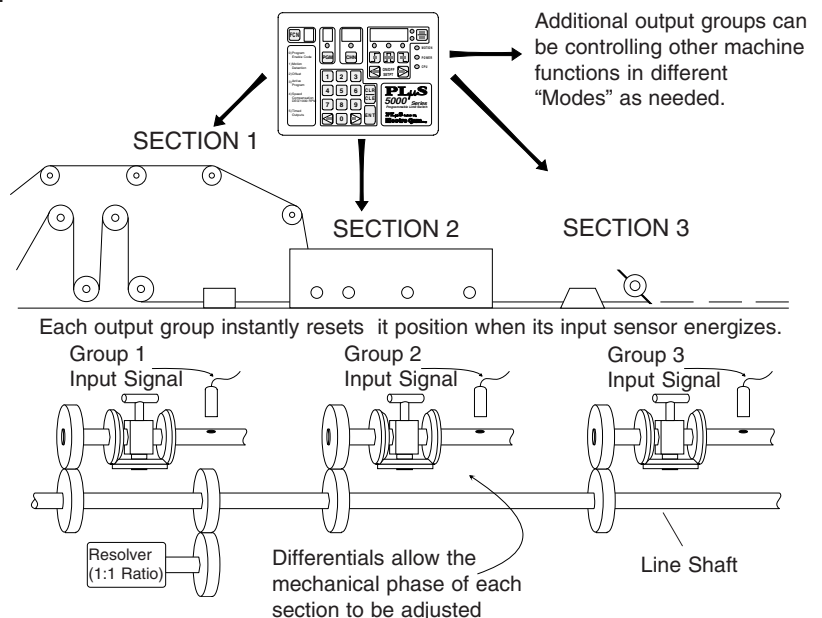

Mode 1 Logic Flow Chart

The flow chart to the right details how Mode 1 operates. The control's response to any set of conditions can be determined by stepping through the flow chart blocks using those conditions when decision blocks are encountered. The flow chart shows when the group enable input is armed and disarmed. Mode 1 logic never disables the outputs, however, Motion ANDing (FCN 7) can disable outputs that are operating in Mode 1.

How to Use the Flow Chart

To use the block diagram assume that the control is continuously processing the blocks at a very fast rate and is never stopped on any one block. The control will get stuck processing the same path of blocks repeatedly (loop) until a condition changes within one of the decision blocks in that loop which alters the path. Response to a condition change is almost instantaneous so the new conditions established in the next loop take affect quickly. Note that the logic path can only flow in the direction of the arrows, never against them.

Rectangle Block



Output enable/disable status or a logic memory flag is altered.

Diamond Block



A yes/no decision is made based on the condition stated within the block.

Mode 1 Flow Chart Blocks

1. Control powers up and assumes position determined by last offset programmed from keyboard (FCN 2).
2. Group enable input is armed. Enable the outputs to cycle at their programmed on/off setpoints.
3. Check for leading edge of group enable input signal. If it occurred go to step 4, if not loop back to step 2.
4. Reset group position to zero. Disarm group enable input.
5. Enable the outputs to cycle at their programmed on/off setpoints. Go to step 6.
6. Check if group position has reached next input window (CHN 9X). If yes go to step 2, if no loop back to step 5.

Note: Position can reach input window from forward or reverse direction.

Mode 1 Logic Flow Chart

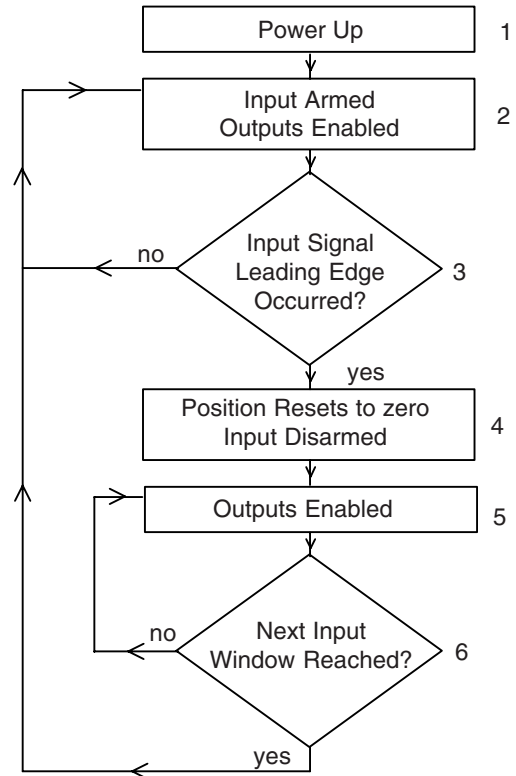

Mode 2 Operation

Details of Mode 2 - Alter Position and Enable Outputs

An output group operating in Mode 2 only has its outputs enabled after an input signal has occurred. The start (leading edge) of an input signal instantly causes the group's position to be reset to zero. The outputs will immediately be enabled to cycle, and will stay enabled until the next input window is reached.

The input signal acts in a momentary manner. Therefore it doesn't matter how long the input remains energized. The reset operation will occur when the leading edge of the input signal occurs. However, once the reset occurs, the control disarms the input and ignores it until it becomes re-armed. A programmed window determines where the input will become re-armed (re-arming the input is similar to cocking a gun - once it is re-armed it can fire at any position). The outputs are disabled when the next input window is reached.

The input window is programmed in the same manner as output pulses and is referenced to the corresponding group position. Channel 91 is the window for Group 1, Channel 92 for Group 2, and so on up to Channel 98. The position of the window determines where the outputs become disabled and where the control starts looking for the next input signal so the process can repeat. **Note: If no window is programmed, output will become active if input is activated and will remain active.**

The position reference that is established by input signals does not get stored in the control's permanent memory. However, it is not important in Mode 2 since the outputs will be disabled until an input signal occurs. On power up, the input is armed, the outputs are disabled and the first input signal received will cause the position to immediately reset to zero.

Example Application: Control different machine functions asynchronously, on demand

This illustration shows a PL μ S control and one resolver "independently" controlling two glue heads at different locations on a conveyor. The spacing between parts being glued is **random**.

Each output group instantly resets its control position when its enable input energizes. The outputs in the group then become active for up to 359 degrees.

Random spacing between parts is automatically handled because each sensor causes the position of its output group to reset. This references the output signals to the leading edge of the part being glued. When parts are not present the outputs will be inactive.

How to Program Mode 2 Operation

1. Program FCN 8 and FCN 9 to correctly establish the output grouping and modes required for this machine application (insure that Mode 2 is selected for this group).
2. Program the input window (CHN 9X) to start at 355 and end at 359 as initial values.
3. Manually crank or jog the machine through a cycle with a product present. After the reset occurs (sensor detects start of product), record the group position values where each of the group outputs needs to cycle on or off. Program these values into the corresponding outputs.
4. Program the input window (CHN 9X) to start before the next valid input signal leading edge will occur. The start of the input window must be after the latest output off position recorded in step 4 (the start of the window disables the outputs) and before the next input signal leading edge. Set the end of the input window to a position that is ahead of the earliest position where group outputs start cycling on.

Note: The group input window (CHN 9X) and the group output position setpoints must be programmed individually for each of the controller programs used. Different programs can have different values as required.

If the output group fails to operate when the machine is run with product present, insure that the group input leading edge occurs after the first programmed window (CHN 9X) and that the input is wired to the control correctly.

The flow chart to the right details how Mode 2 operates.

Mode 2 Example Application

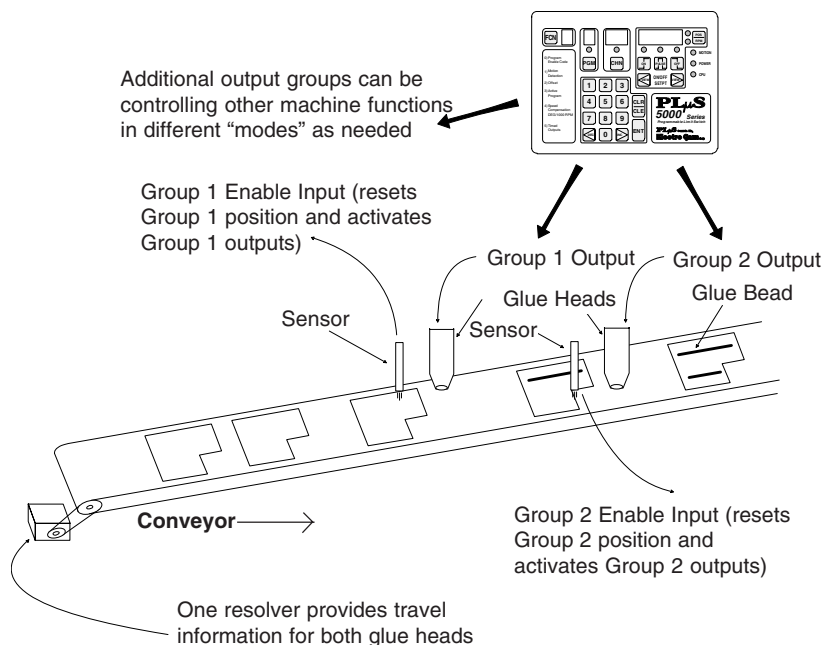

Mode 2 Logic Flow Chart

The control's response to any set of conditions can be determined by stepping through the flow chart blocks using those conditions when decision blocks are encountered. The flow chart determines when the outputs are enabled and disabled by Mode 2 logic. Note: Motion ANDing (FCN 7) can also disable outputs.

How to Use the Flow Chart

To use the block diagram assume that the control is continuously processing the blocks at a very fast rate and is never stopped on any one block. The control will get stuck processing the same path of blocks repeatedly (loop) until a condition changes within one of the decision blocks in that loop which alters the path. Response to a condition change is almost instantaneous so the new conditions established in the next loop take affect quickly. Note that the logic path can only flow in the direction of the arrows, never against them.

Rectangle Block



Diamond Block



Output enable/disable status or a logic memory flag is altered.

A yes/no decision is made based on the condition stated within the block.

Mode 2 Flow Chart Blocks

1. Control powers up and assumes position determined by last programmed offset.
2. Outputs are disabled. Group enable input is armed.
3. Check for leading edge of group enable input signal. If it occurred go to step 4, if not loop back to step 2.
4. Reset group position to zero. Disarm group enable input.
5. Enable the outputs to cycle at their programmed on/off setpoints. Go to step 6.
6. Check if group position has reached next input window (CHN 9X). If yes go to step 2, if no loop back to step 5.

Note: Position can reach input window from forward or reverse direction.

Mode 2 Logic Flow Chart

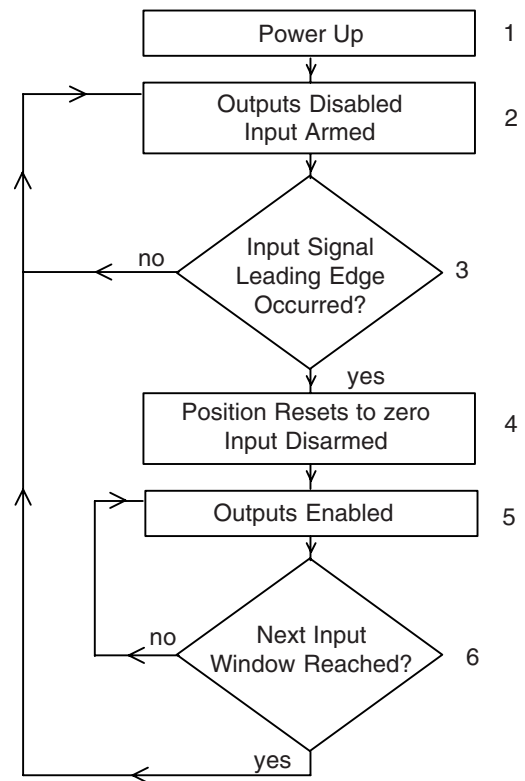

Mode 3 Operation

Details of Mode 3 - AND Outputs with Input Signal

An output group operating in Mode 3 will have the same characteristics as a group operating in Mode 0, except that the corresponding enable input must be on to enable the outputs in this group (acts like the input is in series with each output). When the input is on the outputs will be enabled, but as soon as the input turns off they will be disabled. When the group position is within an output's setpoints, that output would turn on as soon as the input turned on, and would turn off as soon as the input turned off. Therefore, if the input changes state during the pulse, it is possible to only get a partial output pulse. As in Mode 0, position changes can only be made through FCN 2, and position information is maintained in the control's permanent memory.

Use Mode 3 if the group outputs can only be allowed to cycle when a maintained enable signal is present.

How to Program Mode 3 Operation

1. Program FCN 8 and 9 to correctly establish the output grouping and modes required for this machine application (insure that Mode 3 is selected for this group).
2. Check that this group has the desired position relationship to the machine position. Program FCN 2 to adjust it.
3. Program output setpoints to cycle the outputs on and off at the desired output group positions.

No other programming is required for Mode 3 to operate. If an output group operating in Mode 3 fails to cycle its outputs, insure that the input signal is on and wired to the control correctly. Motion ANDING (FCN 7) can also prevent the outputs from cycling.

Example Application: Operate a machine function only while a related input signal is maintained

In this illustration the glue head will only be allowed to operate while the photo eye sees the top edge of a box. Boxes that are crushed or not properly erected will cause the glue function to be aborted when the eye loses sight of the top edge.

Mode 3 operation eliminates the need to hard wire photo eyes and other sensors in series with the corresponding controller outputs. Instead, the sensor input is "ANDed" with the selected output(s) through Mode 3 programming.

Mode 3 Example Application

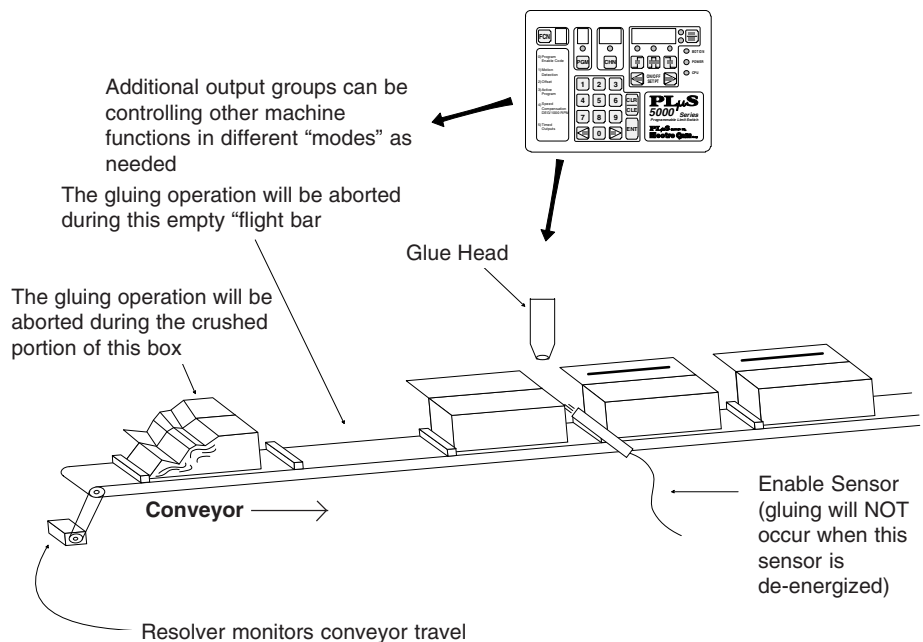

Mode 3 Logic Flow Chart

The flow chart to the right details how Mode 3 operates. The control's response to any set of conditions can be determined by stepping through the flow chart blocks using those conditions when decision blocks are encountered. The flow chart determines when the outputs are enabled and disabled by Mode 3 logic. Note: Motion ANDing (FCN 7) can also disable outputs.

How to Use the Flow Chart

To use the block diagram assume that the control is continuously processing the blocks at a very fast rate and is never stopped on any one block. The control will get stuck processing the same path of blocks repeatedly (loop) until a condition changes within one of the decision blocks in that loop which alters the path. Response to a condition change is almost instantaneous so the new conditions established in the next loop take affect quickly. Note that the logic path can only flow in the direction of the arrows, never against them.

Rectangle Block



Output enable/disable status or a logic memory flag is altered.

Diamond Block



A yes/no decision is made based on the condition stated within the block.

Mode 3 Flow Chart Blocks

1. Control powers up based on the last group position reference that was programmed into FCN 2.
2. Disable outputs (do not allow them to cycle at their programmed position setpoints).
3. Check if group enable input on. Go to step 4 if it is, loop back to step 2 if it is not.
4. Enable outputs to cycle on and off at their programmed position setpoints. Loop back to step 3.

Mode 3 Logic Flow Chart

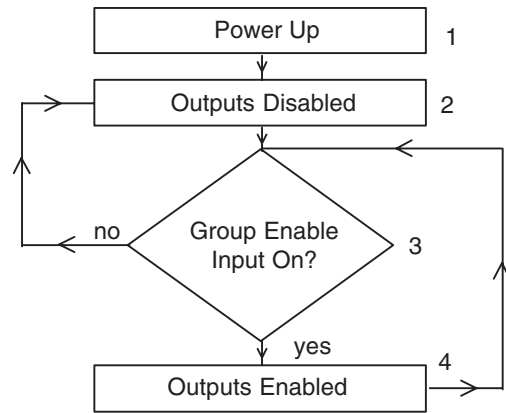

Mode 4 Operation

Details of Mode 4 -

Input Signal Required for Output Cycle

An output group operating in Mode 4 only has its outputs enabled after an input signal has occurred within a specified window of the machine cycle. The start (leading edge) of the input signal will cause the group's outputs to be enabled to cycle, and they will stay enabled until the next input window is reached. The group position is not altered by the input signal.

The input signal acts in a momentary manner, therefore, it doesn't matter how long the input remains energized. However, the leading edge of the input must occur within the programmed input window. The outputs will then become enabled and will remain enabled until the start of the next input window is reached.

The input window is programmed in the same manner as output pulses and is referenced to the corresponding group position. Channel 91 is the window for Group 1, Channel 92 for Group 2 and so on up to Channel 98. The starting position of the window determines where the outputs become disabled and where the control starts looking for the next input signal so the process can repeat.

The position reference for the group is not affected by the input signal. Therefore the group position maintains a constant relationship with the machine position. On power up, the group position will be based on the last position reference that was determined by FCN 2 programming. This reference can only be altered through FCN 2 programming from the keyboard.

Example Application: Operate machine function(s) only if sensor detects part in correct position

In this illustration the punch will operate if the enable sensor detects the leading edge of the part at the correct position in the machine cycle. The presence and correct position of parts is verified by the enable sensor before the group output(s) are activated. The control position remains in sync with the machine position.

The output(s) in the group become active for the remainder of the machine cycle if the enable sensor signal occurs within a specified position in the machine cycle. Sensor signals that occur outside of the programmed "enable input window" will be ignored.

This mode of operation is appropriate for flight bar conveyors, rotary index tables and similar types of machinery.

How to Program Mode 4 Operation

1. Program FCN 8 and FCN 9 to correctly establish the output grouping and modes required for this machine application (insure that Mode 4 is selected for this group).
2. Check that this group has the desired position relationship to the machine position. Program FCN 2 to adjust it.
3. Record the starting position value where the sensor first detects the product as it passes by (leading edge of input).
4. Record the earliest and latest positions where one or more outputs in this group must be on.
5. Program the input window (CHN 9X) to start before the leading edge position of the input signal (recorded in step 3) and end after the leading edge position. The start of the input window must be after the latest output position recorded in step 4 (the start of window disables the outputs) and before the leading edge of the input signal occurs. Set the end of the input window to the latest position in the cycle that a valid input signal leading edge could occur.

Note: The group input window (CHN 9X) and the group output position setpoints must be programmed individually for each of the controller programs used. Different programs can have different values as required.

If the output group fails to operate when the machine is run with product present, insure that the group input leading edge occurs within the programmed window (CHN 9X) and that the input is wired to the control correctly.

Note: Once programmed in a channel, this function will be present in that channel in all programs.

Mode 4 Example Application

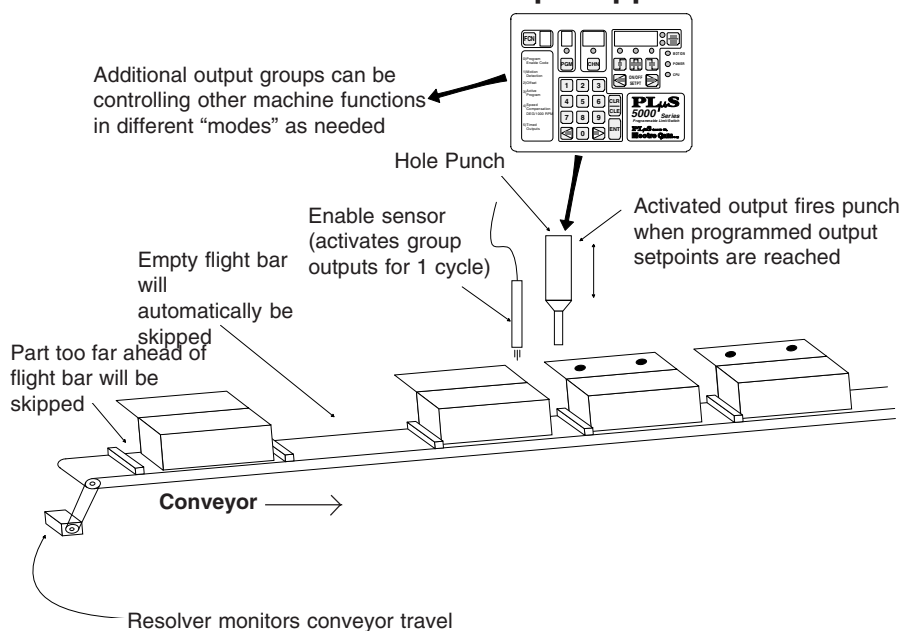

Mode 4 Logic Flow Chart

The flow chart to the right details how Mode 4 operates. The control's response to any set of conditions can be determined by stepping through the flow chart blocks using those conditions when decision blocks are encountered. The flow chart determines when the outputs are enabled and disabled by Mode 4 logic. Note: Motion ANDing (FCN 7) can also disable outputs.

How to Use the Flow Chart

To use the block diagram assume that the control is continuously processing the blocks at a very fast rate and is never stopped on any one block. The control will get stuck processing the same path of blocks repeatedly (loop) until a condition changes within one of the decision blocks in that loop which alters the path. Response to a condition change is almost instantaneous so the new conditions established in the next loop take affect quickly. Note that the logic path can only flow in the direction of the arrows, never against them.

Rectangle Block



Output enable/disable status or a logic memory flag is altered.

Diamond Block



A yes/no decision is made based on the condition stated within the block.

Mode 4 Flow Chart Blocks

1. Control powers up based on the last group position reference that was programmed into FCN 2.
 2. Outputs are disabled.
 3. Check group position within the group input window. Go to step 4 if it is, loop back to step 2 if it is not.
 4. Check for leading edge of group enable input signal. If it occurred go to step 5, if not loop back to step 2.
 5. Enable the outputs to cycle at their programmed on/off setpoints. Go to step 6.
 6. Check if group position has reached next input window (CHN 9X). If yes go to step 2, if no loop back to step 5.
- Note:** Position can reach input window from forward or reverse direction.

Mode 4 Logic Flow Chart

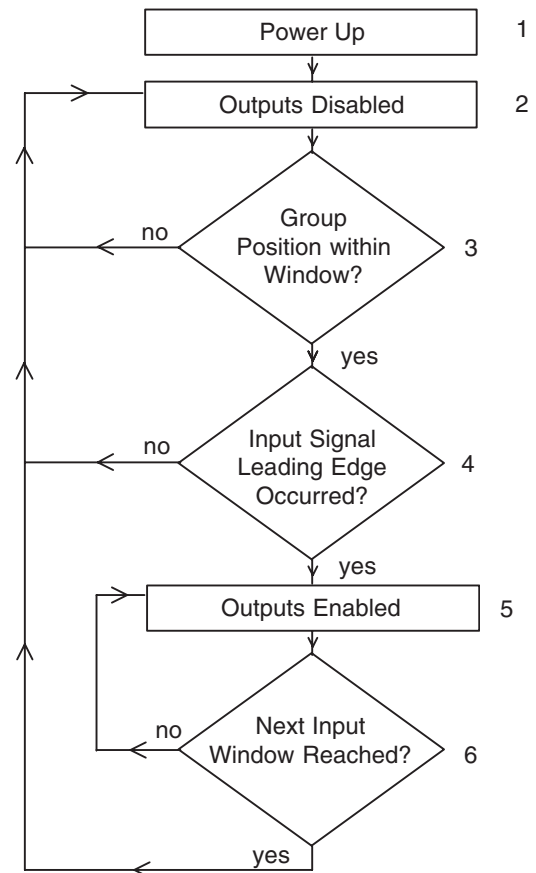

Error Messages

Two types of errors may be displayed:

Programming Programming error messages indicate that a programming attempt was invalid. Except for error message “E0 EErr”, the control will continue to operate the outputs normally during programming errors. Programming error messages will be flagged in the following list with this symbol: 

System System errors occur when conditions are detected that can cause unreliable operation. **All outputs will be disabled when system error messages occur.** The cause of a system error must be determined and corrected before reliable controller operation can be guaranteed. Contact the Electro Cam factory for assistance whenever system error messages repeat. System errors will be flagged in the following list with this symbol: 

CrASH **Watchdog Timer Fault** 
The Watchdog Timer has timed out, indicating that the controller is not properly executing its program. All outputs will be disabled during this error condition. This problem can be caused by severe electrical noise or hardware failure within the control.

Solution: Remove and restore AC input power to the controller. If the control immediately repeats the CrASH error condition each time it is powered up, hardware within the control is damaged. Call Electro Cam for return authorization and further advice.

If CrASH errors occur at intermittent intervals, they are apparently being caused by excessive electrical noise. Check wiring for proper shielding and grounding.

E0EErr **EEPROM Programming Error** 
The Checksum associated with the Function programming (controller’s global configuration) was found to be incorrect.

Solution: Press the CLR/CLE key to clear the flashing error message. All configuration programming and setpoint information will remain unchanged. It will be necessary to re-program all functions that were altered from the factory defaults. (See page A-16, Alt Fcn 7000 for a listing of factory defaults.)

E0FAtL **Memory Fault** 
A problem with random access memory has been detected and the unit cannot function properly. Memory circuitry in the controller is not functioning properly.

Solution: Control must be returned to factory for repair. Call Electro Cam first for return authorization and further information.

E1 CHEC **Checksum Error (Checked on Power-up)** 
The stored checksum value did not match the memory contents when checked on power-up. This problem can be caused by severe electrical noise during power-up or hardware failure within the control.

Solution: Remove and restore AC input power to the controller. If the control immediately repeats the E1 CHEC error condition each time it is powered up, hardware within the control is damaged. Call Electro Cam for further information.

E1 OLAP **Pulse Overlap** 
The output pulse that was just created or adjusted overlaps or touches another pulse that already exists in the same output channel. It was therefore not entered. Also, if one edge of a pulse is moved until it is equal to the other edge, an “E1 OLAP” error will occur.

Solution: Press the CLR/CLE key to clear the flashing error message. Use VIEW keys to review the setpoints that are already programmed on this channel to determine the cause of the overlap condition.

E2run **Item Can Not be Programmed While Running** 
While the encoder/resolver was turning, an attempt was made to change a programmed item that cannot be changed unless the transducer is stationary. Items which cannot be changed while in motion are: Direction of Rotation (FCN 0 - CL/CCL), Scale Factor (FCN 0 - SF), Output Grouping (FCN 8), and Enable Inputs and Modes (FCN 9).

Solution: Press the CLR/CLE key to clear the flashing error message. Stop the machine (transducer) while making the program change.

Error Messages (Continued)

FAtL int

Internal Run Error

There is a hardware problem with internal circuitry. All outputs will be disabled.

Solution: Call Electro Cam for return authorization and further information.

LinEFAiL

Input Power Voltage Low

The input power to the controller dropped below normal operating voltage, causing the controller to stop functioning. Check that input supply voltage to controller is within specified operating range (pg.A-18).

Solution: Control will come out of “LinEFAiL” condition when input voltage rises to normal range.

Pb Stuc

Push Button Stuck

If one of the keyboard keys is on when the unit powers up, this message will be displayed. It can indicate that a key is shorted and always on.

Solution: If “Pb Stuc” error message remains or occurs frequently on power up, call Electro Cam for further information.

StoP

Controller in Stop Mode

When Serial Communication Command 6 (COM_STOP) is sent to the control, it goes into an idle mode and displays the message “StoP”. The Stop mode allows serial information to be written directly into the control's EEPROM memory, thus allowing rapid loading of program information. The PLuSNET DLOAD (down load) program first puts the control in the Stop mode before sending information. When the loading process is complete it returns the control to the run mode. If the loading process is interrupted, the control might accidentally be left in the Stop mode.

Solution: Power cycle the control to restore normal operation.

Communication Port Pin Out and RS-232 Cables

PS-5000 Series DB-9 Connector (Female)

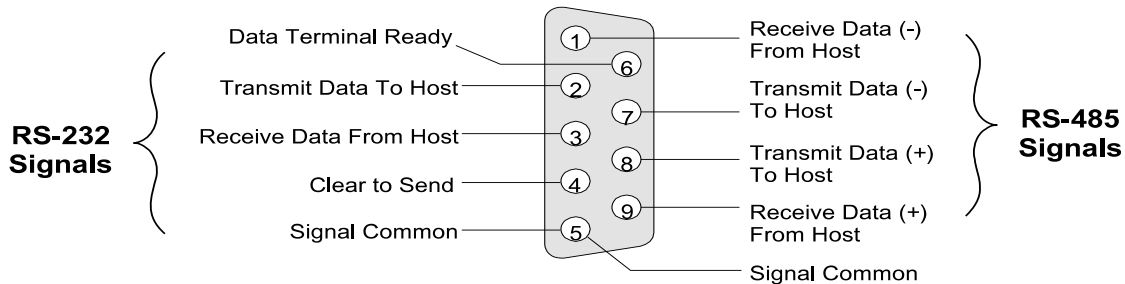

RS-485 can be used for “Multi-Drop” communication (more than one controller connected simultaneously).

RS-232 can be connected to only one control at a time.

For standard 485 communications, pin 4 must be connected to pin 6. If pins 4 and 6 are not connected, controller will communicate with remote display, which will interfere with standard 485 communications.

RS-232 Cable Wiring—DB-25 to DB-9*

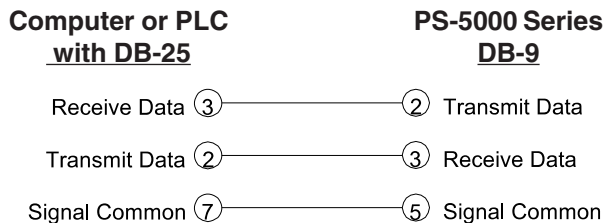

RS-232 Cable Wiring—DB-9 to DB-9*

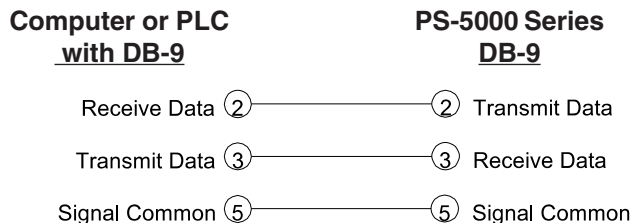

***Pins 1, 4, 6, 7, and 8 must not be connected!**

Damage may result from using an off-the-shelf RS-232 communications cable.

Encoder Position Chart / 60 Pulse Disc for Encoder Based Controls

This table shows how an encoder based PLS control scales 256 increments into degrees. Each increment change is equal to exactly 1/256th of a revolution (approximately 1.4 degrees) even though the position displayed sometimes changes by 2 degrees for a 1 increment change in position (control skips 3s, 7s & 9s).

PLuS = Control Position Deg = Actual Degree Postion

PLuS	Deg	PLuS	Deg	PLuS	Deg	PLuS	Deg	PLuS	Deg	PLuS	Deg
0	0.0	60	59.1	120	119.5	180	180.0	240	239.1	300	299.5
1	1.4	61	60.5	121	120.9	181	181.4	241	240.5	301	300.9
2	2.8	62	61.9	122	122.3	182	182.8	242	241.9	302	302.3
4	4.2	64	63.3	124	123.8	184	184.2	244	243.3	304	303.8
5	5.6	65	64.7	125	125.2	185	185.6	245	244.7	305	305.2
6	7.0	66	66.1	126	126.6	186	187.0	246	246.1	306	306.6
8	8.4	68	67.5	128	128.0	188	188.4	248	247.5	308	308.0
10	9.8	70	68.9	130	129.4	190	189.8	250	248.9	310	309.4
11	11.3	71	70.3	131	130.8	191	191.3	251	250.3	311	310.8
12	12.7	72	71.7	132	132.2	192	192.7	252	251.7	312	312.2
14	14.1	74	73.1	134	133.6	194	194.1	254	253.1	314	313.6
15	15.5	75	74.5	135	135.0	195	195.5	255	254.5	315	315.0
16	16.9	76	75.9	136	136.4	196	196.9	256	255.9	316	316.4
18	18.3	78	77.3	138	137.8	198	198.3	258	257.3	318	317.8
20	19.7	80	78.8	140	139.2	200	199.7	260	258.8	320	319.2
21	21.1	81	80.2	141	140.6	201	201.1	261	260.2	321	320.6
22	22.5	82	81.6	142	142.0	202	202.5	262	261.6	322	322.0
24	23.9	84	83.0	144	143.4	204	203.9	264	263.0	324	323.4
25	25.3	85	84.4	145	144.8	205	205.3	265	264.4	325	324.8
26	26.7	86	85.8	156	146.3	206	206.7	266	265.8	326	326.3
28	28.1	88	87.2	148	147.7	208	208.1	268	267.2	328	327.7
		89	88.6					269	268.6		
30	29.5	90	90.0	150	149.1	210	209.5	270	270.0	330	329.1
31	30.9	91	91.4	151	150.5	211	210.9	271	271.4	331	330.5
32	32.3	92	92.8	152	151.9	212	212.3	272	272.8	332	331.9
34	33.8	94	94.2	154	153.3	214	213.8	274	274.2	334	333.3
35	35.2	95	95.6	155	154.7	215	215.2	275	275.6	335	334.7
36	36.6	96	97.0	156	156.1	216	216.6	276	277.0	336	336.1
38	38.0	98	98.4	158	157.5	218	218.0	278	278.4	338	337.5
40	39.4	100	99.8	160	158.9	220	219.4	280	279.8	340	338.9
41	40.8	101	101.3	161	160.3	221	220.8	281	281.3	341	340.3
42	42.2	102	102.7	162	161.7	222	222.2	282	282.7	342	341.7
44	43.6	104	104.1	164	163.1	224	223.6	284	284.1	344	343.1
45	45.0	105	105.5	165	164.5	225	225.0	285	285.5	345	344.5
46	46.4	106	106.9	166	165.9	226	226.4	286	286.9	346	345.9
48	47.8	108	108.3	168	167.3	228	227.8	288	288.3	348	347.3
50	49.2	110	109.7	170	168.8	230	229.2	290	289.7	350	348.8
51	50.6	111	111.1	171	170.2	231	230.6	291	291.1	351	350.2
52	52.0	112	112.5	172	171.6	232	232.0	292	292.5	352	351.6
54	53.4	114	113.9	174	173.0	234	233.4	294	293.9	354	353.0
55	54.8	115	115.3	175	174.4	235	234.8	295	295.3	355	354.4
56	56.3	116	116.7	176	175.8	236	236.3	296	296.7	356	355.8
58	57.7	118	118.1	178	177.2	238	237.7	298	298.1	358	357.2
				179	178.6					359	358.6

60 Pulse Disc Setpoints for Encoder Based Controls

Pulse	ON	OFF	Pulse	ON	OFF	Pulse	ON	OFF	Pulse	ON	OFF
1.	0	2	16.	90	92	31.	179	181	46.	269	271
2.	6	10	17.	96	100	32.	185	188	47.	275	278
3.	12	15	18.	102	105	33.	191	194	48.	281	284
4.	18	21	19.	108	111	34.	196	200	49.	286	290
5.	25	28	20.	115	118	35.	204	206	50.	294	296
6.	31	34	21.	121	124	36.	210	212	51.	300	302
7.	36	40	22.	126	130	37.	215	218	52.	305	308
8.	42	45	23.	132	135	38.	221	224	53.	311	314
9.	50	52	24.	140	142	39.	228	231	54.	318	321
10.	55	58	25.	145	148	40.	234	236	55.	324	326
11.	61	64	26.	151	154	41.	240	242	56.	330	332
12.	66	70	27.	156	160	42.	245	248	57.	335	338
13.	74	76	28.	164	166	43.	252	255	58.	342	345
14.	80	82	29.	168	171	44.	258	261	59.	348	351
15.	85	88	30.	174	176	45.	264	266	60.	354	356

Alternate Functions - Utilities and Hardware Testing

Alternate functions test and/or display the hardware status of the control or perform programming operations. Below is an itemized list of each Alternate Function.

To access Alternate Functions:

1. Press FCN and POS/RPM keys simultaneously.
2. Press numeric keys of Alt Fcn desired.
3. Press ENT key.

Note: Master Program Enable must be On.

Press POS/RPM key to exit Alternate Functions

Alt Fcn 1: Displays Actual Position of Transducer

Resolver: 0-1023 (10 bits) or 0-4095 (12 bits, "H" option)
Encoder: 0-255 (8 bits)

Alt Fcn 2: Displays On (1) Off (0) Status of Logic Inputs

Setpoint Display shows: Program Select Inputs (term 3-5)
Master Program Enable (term 6)
Channel Display shows: Output Group Enable 1 (term 7)
Operator Program Enable (term 9)

Alt Fcn 3: Displays Absolute Value of the Current Offset

This is the number of increments that the control position is leading the transducer position. Example: if Alt Fcn 3 displays a value of 90, the control will be at 90 when the transducer is at its absolute 0 position.

Alt Fcn 4: 60 Pulse Disc

Programs a 60 pulse disc into the last channel of the current active program.

Note: Controls with Analog ("-A") option or Phase Mark Registration ("-P") option do not have this function.

Alt Fcn 1002: Keyboard Test

While each key is pressed a unique number is displayed (99 is displayed if no key is pressed). THE CONTROL MUST BE POWER CYCLED TO EXIT THE KEYBOARD TEST.

Alt Fcn 1003: LED Display Test

All 7 segment Leds will first be turned on, then each Led segment will be lit individually, followed by each of the discrete Leds. The test repeats until a key is pressed.

Alt Fcn 1004: Watchdog Timer Test

This test prevents control's internal "Watchdog Timer" circuit from being reset. If Watchdog Timer is functioning properly, the control will reset. Some versions may display "CrASH". Press any key to restart the control.

Alt Fcn 1005: Display Control Model Information

Function display: "L" if control has Leading/Trailing comp
Program display: Graycode output option (0=No, 1=Yes)
Channel display: Number of I/O channels
Setpoint display: Basic model number (5001, 5104, etc)

Alt Fcn 1006: Display Options and Revision

Function display: "P" if control has Register Mark Phasing
Program display: "A" if control has Analog
Channel display: first digit: "c" if control has Serial Comm
2nd digit: "H" if High Resolution control
Setpoint display: Software Rev # (ex: 507 = Rev 5.07)

Alt Fcn 7000: Restore Factory Defaults and Clear All Output Channel Setpoints

Control will scroll through memory locations shown in position display for approximately 45 seconds, then reset and display "EO EErr". On some versions "CrASH" will be displayed when operation is completed. Press CLR/CLE key to restore normal operation.

Factory Defaults are:

FCN 0	dr = CCL	FCN 1	Lo = 10
	SF = 360		Hi = 3000
			Ao = 0
			Ah = 2047
	P1 = 0000	FCN 3	AP = 1 Pb = 1
	P2 = 0000	FCN 4	All Channels 0
	Sc = onE	FCN 5	All Channels 0
	tb = 1	FCN 6	All Channels Off
	ct = 485	FCN 7	All Channels Off
	cS = 9600	FCN 8	1 Group, All Channels
	cA = 1	FCN 9	1 Input, Mode 0
	dd = SPd		
	tr = 20		

Alt Fcn 7001: Clear All Output Channel Setpoints

Control will scroll through memory locations shown in position display for approximately 25 seconds. "7001" will be displayed when operation is completed. Press any key to restore normal operation.

Alt Fcn 7999: Extensive EEPROM Test

(Restores Defaults and Clears All Channel Setpoints)
Control will scroll through memory locations shown in position display for approximately 6-1/2 minutes. "EO EErr" will be displayed when operation is completed. This error will show up once at the end of the test, and is not a problem unless it occurs during normal operation. "CRASH" will be displayed on older versions. Press CLR/CLE key to restore normal operation.

If a problem is found with the EEPROM the display will latch up with the bad memory location address shown. Call Electro Cam for further information if this happens.

Remote Display Installation, Wiring and Setup

Dimensioned / Wiring Drawing

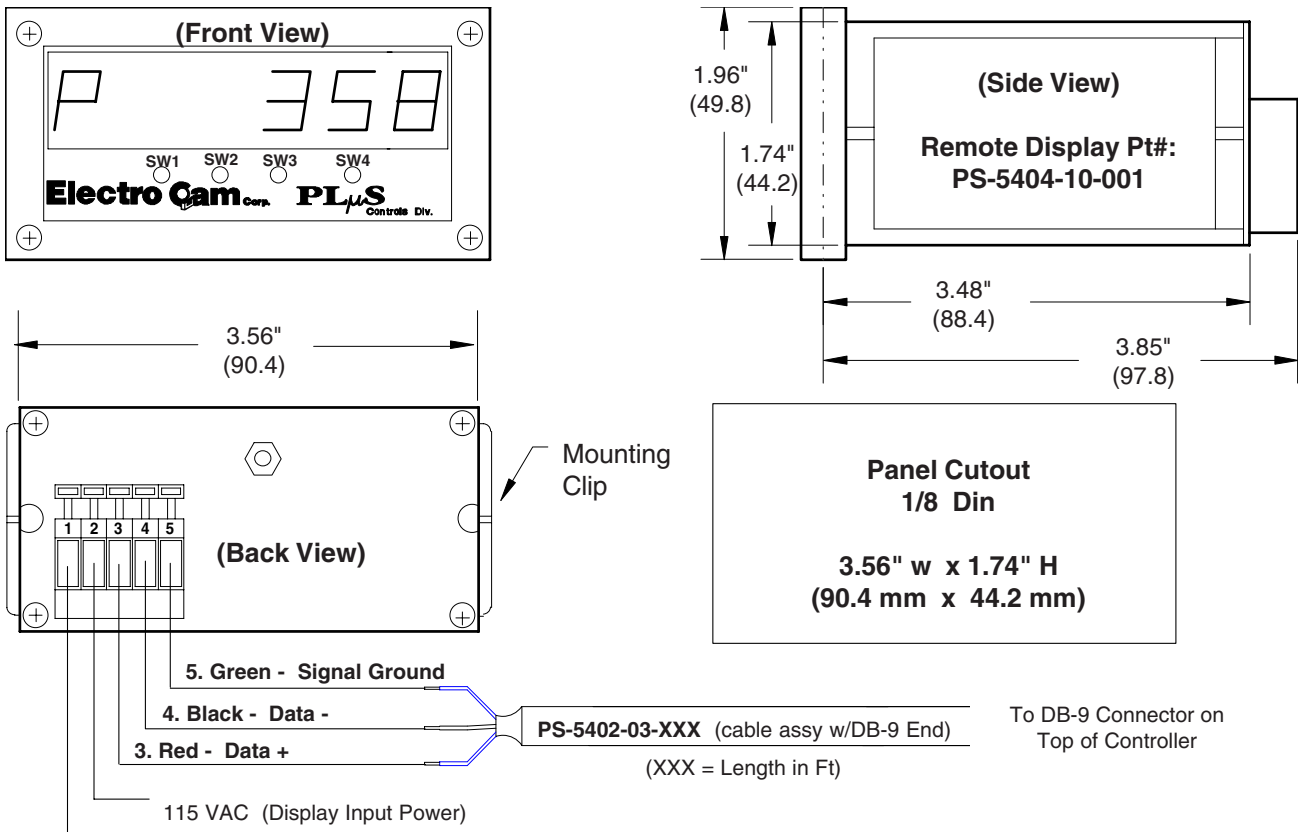

Display Operation

The remote display receives data from the PLμS control via RS-485 serial communication. **NOTE: Prior to date code 9740, the “-E” and “-C” options were required for communications.** The display will show either the controller's present rotary position or RPM as follows:

P 3 5 9 (example of position 359 shown by remote display)
r 2 5 0 (example of 250 RPM shown by remote display)

The toggle RPM (“tr”) value programmed in FCN 0 determines the speed at which the display switches from showing position to RPM. At speeds below the toggle RPM value, position will be shown. At speeds equal to or above toggle RPM, the current RPM value will be displayed. It is not necessary for the control's display default (“dd”) to be set to auto; the display will automatically switch between position and RPM at the toggle RPM value, regardless of what the control's display is showing. The value of RPM update (“ru”) will determine how many times per second the display updates RPM.

To display position at all times, set the toggle RPM to a number that is higher than the maximum speed of the machine. To display RPM at all times set the toggle RPM to zero.

Note: A jumper between term 4 & 6 on the PLμS comm port will disable display data to allow normal serial communication.

Controller / Display Setup

Controller

- Setup these FCN 0 items in the PLμS control as follows:
- cS = 9600** 9600 baud selected for communication speed. This is the fastest speed at which the display will operate, and is the factory default speed for the controller.
 - ct = 485** RS-485 format selected for serial port. **Display data will not be transmitted by the controller when in the RS-232 mode.**
 - tr = ?** Select the RPM value where display switches from showing position to RPM

Display

All of the programmable items in the display will be correctly set at Electro Cam before the display is shipped. This information is stored in permanent memory in the display and should never have to be programmed. However, if the display does not operate when connected to the control, check for correct display settings as follows:

1. Press SW1 & SW2 simultaneously until the message “b_rate” is displayed for one second. The current baud rate will appear.
2. If the current baud rate is 9600, go to Step 3. Otherwise, press SW3 until 9600 is displayed.
3. Press SW1 to store the 9600 baud rate and return to normal operation.

Controller Specifications

Electrical

24 VDC 20-30 VDC
120 VAC 50/60 Hz: 108 - 132 VAC
240 VAC 50/60 Hz: 216 - 264 VAC
Power Consumption: 35 VA
Permanent Memory: EEPROM (no battery required)
 min. 100,000 write cycles
Access. Power Out: 12 VDC, 150 mA
Terminal torque: 4.5 inch-lbs.
Use copper 60/75-C wire only

Environment

Operating Temp: 0° to 50°C (32° to 122°F)
Storage Temp: -40° to 50°C (-40° to 122°F)
Operating Humidity: 95% Relative non-condensing
NEMA Rating: For use on type 1, 4, 4X or 12 enclosure

Fuses:

20-30 VDC Operation: 1.25A, 250V, SB
120 VAC Operation: 0.5A, 250V, SB
240 VAC Operation: 0.25A, 250V, SB

Physical

Overall Dimensions: 8.5"W x 6.5"H x 4.5"D
Panel Cutout Size: 7.38"W x 5.38"H
Weight: 4 Lbs.

Operation

Scan Time: 250 μ s to 500 μ s - Higher speed units available—consult factory

Position Resolution: 10 bits (1024 increments - resolver, standard control)
 12 bits (4096 increments - resolver, "-H" option control)
 8 bits (256 increments +/- 0.7 Deg - Gray Code encoder)

Speed Compensation: Programmed in Deg/1000 RPM for each output individually (24 I/O systems and higher: 16 compensated outputs maximum) Updated 10 times per second. Leading/trailing edge option (update time determined by programming, typically 5 to 10 times per sec)

Output Timeout: 0.5 or 1.0 ms time base (accuracy: +1,-0 time increments)

Number of Timed Outputs: 1.0 ms time base: 8 timed outputs
 0.5 ms time base: 4 timed outputs (24 and 48 I/O systems have 1.0 ms time base only - up to 4 timed outputs)

Multiple Programs: 64 Prgms. on 8, 9, & 16 I/O units
 48 Programs on 24 I/O units
 24 Programs on 48 I/O units

Maximum RPM: Encoder: 2000 RPM
 Resolver: Up to 3000 RPM
 Depending on specific model & optional features - Higher speed units available—consult factory

Input Responses

Program Select: 100 ms (Hardware response + processing time)

Output Group Enables: 1 Scan

Serial Communication ("C" Option)

Port Types: 1 RS-232 and 1 RS-422/485
Baud Rates: 4800, 9600, 19.2K, 38.4K

Note: RS-485 can be configured as a "Multi-Drop" network.

Analog Output ("A" Option - proportional to RPM)

Output Types: 4-20 mA or 0-10 VDC
Resolution: 12 Bit Analog Hardware (Speed is calculated in whole RPM and will determine the actual number of analog steps available in any specific applications.)

Update Time: 100 ms
Linearity: +/- 0.3% full scale @ 25°C (77°F)

Transducer Specifications

ENCODER(S)

Operating Temp:	0° to 50°C (32° to 122°F)
Storage Temp:	-40° to 50°C (-40° to 122°F)
Operating Humidity:	95% Relative non-condensing
NEMA Rating:	NEMA 12 (PS-4256, 4257) NEMA 4X (PS-4456, 4457)
Max Cable Length:	1000 Ft.
Enclosure Size:	6"W x 6"L x 4.25"H
Mounting Holes (4):	5/16" Diameter
Weight:	9 Lbs.
Shaft Diameter:	.75" (double ended) with Woodruff keyway #606
Maximum RPM:	1000 RPM (PS-4256, 4456) 2000 RPM (PS-4257, 4457)
Resolution:	8 Bits (256 increments)
Accuracy:	+/-0.7°

RESOLVER(S)

Operating Temp:	-40° to 125°C (-40° to 257°F)
Storage Temp:	-40° to 125°C (-40° to 257°F)
Operating Humidity:	95% Relative non-condensing
NEMA Rating:	NEMA 4 NEMA 4X
Maximum RPM:	3000 RPM
Max Cable Length:	1000 Ft.
Type:	Single Turn - Brushless
Resolution (all):	12 Bits (4096 increments)
Linearity (standard):	+/-20 arc minutes (resolver only) (+/-30 arc minutes combined with R/D converter in controller)
Linearity (specials):	+/-3 to +/-10 arc minutes (resolver only) (+/-7 to +/-14 arc minutes combined with R/D converter in controller)

Note: A resolver's linearity errors are repeatable at all positions of its 360 degree rotation. Therefore, once appropriate setpoints are established, machine performance is consistent every cycle.

AC/DC Output Module Specifications

AC Outputs: EC-OAC5A-11 (Standard) EC-OAC240-3 (Slimline)

Load Voltage: 24 V rms minimum
280 V rms maximum

Load Current: 30 mA rms minimum
3 A rms max. @/below 35°C (95°F)
Above 35°C derate 50 mA/°C
(27.8 mA/°F)

Input Voltage: 5 VDC nominal
8 VDC maximum

Turn On Time: 100 µs maximum @ 60 Hz

Turn Off Time: 8.3 ms maximum @ 60 Hz

Off State Leakage: 2 mA AC rms @ 120 VAC rms,
60 Hz

Frequency: 65 Hz maximum

On State Volt. Drop: 1.6 V peak maximum

Dropout Voltage: 1 VDC maximum

Pickup Voltage: 2.5 VDC minimum

Operating Temp: -30 to +70°C (-22° to +158°F)

DC Outputs: EC-ODC5 (Standard) EC-ODC060-3 (Slimline)

Output Voltage: 0 to 60 VDC

Output Current: 3 A @/below 35°C (95°F)
Derate 35.7 mA/°C above 35°C
(19.8 mA/°F above 95°F)

Input Voltage: 5 VDC nominal
8 VDC maximum

Turn On Time: 50 µs maximum

Turn Off Time: 50 µs maximum

Off State Leakage: 1 µA DC maximum @ 24 VDC

Output Voltage Drop: 1.6 V peak maximum

Dropout Voltage: 1 VDC maximum

Pickup Voltage: 2.5 VDC minimum

Operating Temp: -30 to +70°C (-22° to +158°F)

DC Outputs: EC-ODC5A (Standard) EC-ODC200-1 (Slimline)

Output Voltage: 0 to 200 VDC

Output Current: 1 A @/below 45°C (113°F)
Derate 18 mA/°C above 45°C
(10 mA/°F above 113°F)

Input Voltage: 5 VDC nominal
8 VDC maximum

Turn On: 50 µs maximum

Turn Off: 50 µs maximum

Off State Leakage: 1 µA DC maximum @ 24 VDC

Output Voltage Drop: 1.75 VDC maximum

Dropout Voltage: 1 VDC maximum

Pickup Voltage: 2.5 VDC minimum

Operating Temp: -30 to +70°C (-22° to +158°F)

Reed Relays: EC-ORR5 (Standard)

Output Type: N/O Reed Relay Contacts

Contact Rating: 10VA maximum
(DC resistive load)

Switching Volts: 0 V to 200 V, DC or peak AC

Switch Current: 0.5 A maximum, DC or peak AC
(resistive loads only)

Carry Current: 1.0 A maximum, DC or peak AC

Turn On Time: 1 ms

Turn Off Time: 500 µs

Mechanical Life: 50 million cycles min at rated load

Operating Temp: -30 to +70°C (-22° to +158°F)

Reed Relays: EC-ORR000-0 (Slimline)

Output Type: N/O Reed Relay Contacts

Contact Rating: 10 VA maximum

Switching Voltage: 100 VDC or 130 VAC maximum

Switching Current: 0.5 A maximum

Carry Current: 1.5 A maximum

Turn On Time: 500 µs

Turn Off Time: 500 µs

Mechanical Life: 5 x 10⁶ cycles

Operating Temp: -30 to +70°C (-22° to +158°F)

Analog Output Module Specifications

0-10 VDC: **EC-ANLG-010V (Standard)**
 EC-SANL-010V (Slimline)
Resolution: 12 Bits (4096 increments)
Output Voltage: 0-10 VDC
Output Current: 140 mA DC maximum
Accuracy: +/- 0.3% full scale @ 25°C (77°F)

4-20 mA: **EC-ANLG-420M (Standard)**
 EC-SANL-420M (Slimline)
Resolution: 12 Bits (4096 increments)
Output Current: 4 mA DC to 20 mA DC
Load Resistance: 450 Ohms maximum
Accuracy: +/- 0.3% full scale @ 25°C (77°F)

Input Module Specifications

DC Inputs: **EC-IDC5 (Standard)**
 EC-IDC032 (Slimline)

Input Voltage: 10-32 VDC
Input Current: 34 mA maximum (@32 VDC input)
Output Supply
 Voltage: 4.5 VDC to 6 VDC
 5 VDC nominal

Output Supply
 Current: 18 mA DC maximum @ 5 VDC
Turn On Time: 5 ms maximum
Turn Off Time: 5 ms maximum
Dropout Voltage: 2 VDC maximum
Pickup Voltage: 3 VDC minimum
Operating Temp: -30 to +70°C (-22° to +158°F)

AC Inputs: **EC-IAC5 (Standard)**
 EC-IAC120 (Slimline)

Input Voltage: 90-140 VAC rms
Input Current: 11 mA AC rms maximum
 (@140 VAC rms input)

Output Supply
 Voltage: 4.5 VDC to 6 VDC
 5 VDC nominal

Output Supply
 Current: 16 mA DC maximum @ 5 VDC
Off State Leakage: 100 μ A DC maximum @ 30 VDC
Output Voltage Drop: 0.4 VDC @ 50 mA DC
Output Current: 50 mA DC maximum
Turn On Time: 20 ms typical
Turn Off Time: 20 ms typical
Input Allowed
 for No Output: 45 VAC rms,
 3 mA AC rms maximum

Operating Temp: -30 to +70°C (-22° to +158°F)

AC Inputs: **EC-IAC5A (Standard)**
 EC-IAC240 (Slimline)

Input Voltage: 180-280 VAC rms
Input Current: 5 mA AC rms maximum
 (@280 VAC rms input)

Output Supply
 Voltage: 4.5 VDC to 6 VDC
 5 VDC nominal

Output Supply
 Current: 16 mA DC maximum @ 5 VDC
Off State Leakage: 100 μ A maximum @ 30 VDC
Output Voltage Drop: 0.4 VDC @ 50 mA DC
Output Current: 50 mA DC maximum
Turn On Time: 20 ms typical
Turn Off Time: 20 ms typical
Input Allowed
 for No Output: 45 VAC rms,
 1 mA AC rms maximum

Operating Temp: -30 to +70°C (-22° to +158°F)

Transistor Output Specifications

Sinking Transistor Outputs (PS-5X11, N08 and N16)

Output Type: Current Sinking (NPN)
Output Voltage: 5 - 30 VDC
Output Current: 50 mA cont. maximum
Input Voltage: 5 - 30 VDC

Sourcing Transistor Outputs (PS-5X11, P08 and P16)

Output Type: Current Sourcing (PNP)
Output Voltage: 5 - 30 VDC
Output Current: 50 mA cont. maximum
Input Voltage: 5 - 30 VDC

Index

+12 VDC Output (Logic Terminal Strip)	3-1	Communications	4-6
60 Pulse Disc		cA, Communication Address	4-6
ALT FCN 4: Create 60 Pulse Disc	A-16	cS, Communication Speed	4-6
Output Setpoints (Encoder)	A-15	cT, Communication Type (RS-232, -485)	4-6
Absolute Offset (ALT FCN 3)	A-16	Ports	A-14
Active Program		Wiring	A-14
Standard Controllers	3-1, 4-10	Controller	
Operator Access on/oFF	4-7	Cut-out	2-1, 2-2, 2-3
Option “-F”, Extra Program Storage	5-4	Back View (Component Identification)	2-1, 2-2, 2-3
Access Levels	4-1	Front View (Keyboard)	4-2
Ah (FCN 1)—See Analog Output		Specifications	A-18
Alternate Functions	A-16	CrASH (SYS Error Message)	A-12
ALT FCN 1: Display Transducer Position		CPU LED	4-2
ALT FCN 2: Display Input Status		cS (FCN 0)—See Communications	
ALT FCN 3: Display Absolute Offset		cT (FCN 0)—See Communications	
ALT FCN 4: Create 60 Pulse Disc			
ALT FCN 1002: Keyboard Key Test		“-D” Option	5-2
ALT FCN 1003: LED Display Test		DEC Key	4-2
ALT FCN 1004: Watchdog Timer Test		Default Settings	A-16
ALT FCN 1005: Display Control Model Info		Deg / 1000 RPM (See Speed Compensation)	
ALT FCN 1006: Display Options and Rev #		Direction of Rotation (FCN 0 dr)	4-4
ALT FCN 7000: Restore Factory Defaults		Direction of Rotation, Outputs Based on Resolver	5-2
ALT FCN 7001: Clear All Channel Setpoints		Display Default (FCN 0 dd)	4-5
ALT FCN 7999: Extensive EEPROM Test		Display, Remote	A-17
Analog Output, Option “-A”	1-2, 5-2	dd (FCN 0)	4-5
Ah, Analog High RPM	5-2	dr (FCN 0)	4-4
Ao, Analog Offset	5-2		
Analog Output Module Information	A-21	E0 EErr (PGM Error Message)	A-12
Analog Output Module Wiring	3-4	E0 FATL (SYS Error Message)	A-12
Module Mounting Position		E1 CHEC (SYS Error Message)	A-12
External 16 Standard Module Rack	3-2	E1 OLAP (PGM Error Message)	A-12
External M16 Slimline Module Rack	3-2	E2 run (PGM Error Message)	A-12
External 24 & 48 Standard Module Racks	3-3	E4 -Pro (PGM Error Message)	A-13
Slimline Modules on Controller Back	3-4	E5 8888 (PGM Error Message)	A-13
ANDing		E6 -379 (PGM Error Message)	A-13
Input ANDing (Mode 3)	A-8	E7 -dEF (PGM Error Message)	A-13
Motion ANDing (FCN 7)	4-8	E9 tdE (PGM Error Message)	A-13
Ao (FCN 1)—See Analog Output		E10 -rES (SYS Error Message)	A-13
AP (FCN 3)—See Active Program		E11 -ScE (PGM Error Message)	A-13
Auto (FCN 0)	4-5	Enable Inputs	
		Output Group Enable 1 (Re-Zero Input)	3-1
Back View of Controller	1-3, 2-1, 2-2, 2-3	Program Enable	3-1, 4-1
both (FCN 0)	5-1	Enable Codes, P1 & P2 (FCN 1)	4-4
cA (FCN 0)—See Communications		Encoder	
Cables		Cable Installation	3-16
Communication	A-14	Position Chart	A-15
Encoder	3-16	ENT Key	4-2
Resolver	3-14	Error Messages (Flashing)	
ccL (FCN 0)	4-4	Programming	4-3, A-12, A-13
CHN Key	4-2	System	A-12, A-13, A-14
CHN 14, 15, 80, 81 (Option “P”)	5-7	Factory Default Settings (Functions)	A-16
cL (FCN 0)	4-4	FATL_int (SYS Error Message)	A-14
CLR/CLE Key	4-2	FCN Key	4-2

Index

- FCN 0
 - All Controllers
 - Direction of Increasing Rotation (dr) 4-4
 - Display Default (dd) 4-5
 - Enable Codes (P1 & P2) 4-4
 - Factor (SF) 4-4
 - Time Base (tb) 4-5
 - Toggle RPM (tr) 4-5
 - Communications
 - Communication Address (cA) 4-6
 - Communication Speed (cS) 4-6
 - Communication Type (ct) 4-6
 - Expanded Operator Access
 - RPM Update Frequency (rU) 4-6
 - Option “-L”, Leading/Trailing Edge Speed Comp
 - Standard Speed Comp (onE) 5-1
 - Leading/Trailing Edge Speed Comp (both) 5-1
- FCN 1
 - All Controllers—Motion Detection Setpoints
 - Lo -Low RPM Value for Speed Range 4-10
 - Hi -High RPM Value for Speed Range 4-10
 - Option “-A”, Analog Output
 - Ao -Analog Offset 5-2
 - AH -Analog High RPM Value 5-2
- FCN 2: Offset (position) 4-10
- FCN 3: Active Program
 - Active Program (AP) 4-11
 - Program Bank (pB) 4-11
 - Program Number (pN) 4-11
 - Option “-F”, Extra Program Storage
 - Active Program (AP) 5-5
 - Program Bank (pB) 5-5
 - Program Number (pN) 5-5
- FCN 4: Speed Compensation
 - Standard Controllers
 - Standard Speed Comp 4-12
 - Negative Speed Comp (Input Gating) 4-12
 - Option “-L”, Leading/Trailing Edge Speed Comp
 - onE 5-1
 - both 5-1
 - Option “-G”, Gray Code Speed Comp 5-3
- FCN 5: Timed Outputs 4-13
 - Operator Access on/oFF 4-7
- FCN 6: Operator Output Channels
 - Standard Controllers
 - Operator Can Adjust (on) 4-7
 - Operator Cannot Adjust (oFF) 4-7
 - Active Program On/Off (AP) 4-7
 - Offset On/Off (oF) 4-7
 - Speed Comp On/Off (Sc) 4-7
 - Speed Detection On/Off (Sd) 4-7
 - Setpoints On/Off (SP) 4-7
 - Timed Outputs On/Off 4-7
- FCN 7: Motion ANDed Channels 4-8
- FCN 8: Output Grouping 4-9
- FCN 9: Output Enable Modes 4-9
- Flashing Error Messages 4-3, A-12, A-13, A-14
- Fuses
 - 12 VDC Power Supply (Logic Terminal Strip) 3-1
 - Controller Input Power (1/2 Amp) 2-1, 2-2, 2-3
 - Logic Terminal Strip (12 VDC Power Supply) 3-1
 - Rack, 16 Standard Modules 3-2
 - Rack, 16 Slimline Modules (M16 Rack) 3-2
 - Rack, 24 & 48 Standard Modules 3-3
 - Slimline Modules on Controller Back 3-4
 - Transistor Outputs 3-7
- Gray Code Output, Option “-G” 1-2, 5-3
- Group 1 Output Enable (Re-Zero Input) 3-1
 - (on 5XX4 models see Modes 1 & 2)
- High Resolution, Option “-H” 1-2
- “Hi” (FCN 1), Motion Setpoints 4-10
- INC Key 4-2
- Input Gating (Negative Speed Comp) 4-12
- Input Modules
 - Specifications A-22
 - Wiring 3-5
- Input Power Wiring 2-1, 2-2, 2-3
- Input Sensor, 3-Wire 3-5
- Inputs (Logic Terminal Strip) 3-1
- Keyboard 4-2
 - Displays 4-2
 - Enable Codes 4-1, 4-4
 - Hardware Test Functions A-16
 - Keys 4-2
 - LEDs 4-2
- Leading/Trailing Speed Comp (Option “-L”) 5-1
- Levels of Programming Access 4-1, 4-8
- LinEFAiL (SYS Error Message) A-14
- Lo (FCN 1) 4-10
- Logic Common (Logic Terminal Strip) 3-1
- Logic Terminal Strip (Inputs) 3-1
- Master Level Programming Access 4-1
- Master Program Enable Input 3-1
- Modes of Operation
 - Input Programming (FCN 9) 4-9, A-1, A-2
 - Introduction 1-2, A-3
 - Output Grouping (FCN 8) 4-9, A-1, A-2
 - Mode Programming (FCN 9) 4-9, A-1, A-2
- Mode 0 A-3
- Mode 1 A-4, A-5
- Mode 2 A-6, A-6
- Mode 3 A-8, A-9
- Mode 4 A-10, A-11
- Modules, Input/Output
 - Specifications A-20, A-21, A-22
 - Wiring 3-4, 3-5

Index

Motion ANDing (FCN 7)	4-8	Program Select Inputs	3-1
Motion Detection		PULSE Key	4-2
Setpoints (FCN 1)	4-10	Pulse Mode (Output Adjustment)	4-3
Output	3-1	Remote Display	A-17
Operator Access on/oFF	4-7	Resolver	
Motion LED	4-2	Cable	3-14
Mounting the Control	2-1, 2-2, 2-3	Flange Mount	3-14
Multiple Programs		Foot Mount	3-14
Hardware Inputs	3-1	Specifications	A-19
See Also FCN 3		Wiring	3-14
Multi-Pulse Mode (Setpoint Adjustment)	4-3	Re-Zero Input (Output Group 1 Enable) (on 5XX4 models see Modes 1 & 2)	3-1
OFF Key	4-2	rU (FCN 1) RPM Update Frequency	5-4
Offset (Position)		RS-232 Cable Wiring Information	A-14
ALT FCN 3, Display Offset	A-16	RS-232 Terminal Identification	A-14
FCN 2, Program Offset	4-10	RS-485 Terminal Identification	A-14
Operator Access on/oFF	4-7	“Sc” (FCN 0)	5-1
ON Key	4-2	Scale Factor (FCN 0 SF)	4-4
“onE” Option “-L”, Leading/Trailing Speed Comp	5-1	Serial Communication (See Communications)	
Operator Access		Sensor Wiring, 3-Wire Sensor Input	3-5
Standard Controllers		Setpoints	
Access Level	4-1	Operator Access On/Off	4-7
Enable Code	4-4	Programming Output	4-3
Program Enable Input	3-1, 4-1	Set-up	
Output Group 1 Enable (Re-Zero Input)	3-1	Access Level	4-1
Output Grouping (FCN 8)	4-9, A-1, A-2	Enable Code	4-4
Output Modules		“SF” (FCN 0)	4-4
Specifications	A-20, A-21	Sinking	
Wiring	3-4, 3-5	Inputs	3-5
Output Racks		Outputs	3-4, 3-8
16 Standard Modules	3-2	Sourcing	
16 Slimline Modules (M16 Rack)	3-2	Inputs	3-5
24 & 48 Standard Modules	3-3	Outputs	3-4, 3-7
Output Setpoint Programming		“Spd” (FCN 0)	4-5
Operator Access On/Off	4-7	Speed Compensation (FCN 4)	
Programming Output		Gray Code (Option “-G”)	5-3
P1 (FCN 0)	4-4	Leading/Trailing Edge (Option “-L”)	5-1
P2 (FCN 0)	4-4	Negative (Input Gating)	4-12
Panel Layouts	2-1, 2-2, 2-3	Operator Access on/oFF	4-7
Pb (FCN 3)	4-8	Standard	4-12
Pb Stuc (SYS Error Message)	A-14	Speed Detection, Sd (on/oFF)	
PGM Key	4-2	Operator Access on/oFF	4-7
Phase Registration, Option “-P”	1-2, 5-10	See Also Motion Detection	
PLC Wiring (Transistor Outputs)	3-9	Standard Features	1-2
PlusNet	1-2	“StoP” (SYS Error Message)	A-14
PoS (FCN 0)	4-5	Suppressors	3-4, 3-7
POS/RPM Key	4-2	System Error Messages	A-12, A-13, A-14
Power LED	4-2	“tb” (FCN 0)	4-5
Power Output Module Wiring	3-2, 3-7	Timed Outputs	4-13
Program Enable		Toggle RPM	4-5
Codes	4-1, 4-4		
Inputs	3-1		
Programming			
Access Levels	4-1		
Error Messages	4-3, A-12, A-13, A-14		
Features	1-1		

Index

“tr” (FCN 0)	4-5
Transistor Output	
Replacement	3-6
Specifications	A-23
Terminals	3-7, 3-8
Wiring	
Sinking Transistors	3-8
Sourcing Transistors	3-7
Sinking Transistors to PLC	3-9
Sourcing Transistors to PLC	3-9
VIEW Keys	4-2
Wiring	
12 VDC Power Output	3-1, 3-5
Analog Output	3-4
Communication	A-14
Encoder	3-16
Inputs (Logic Terminal Strip)	3-1
Input Power (Controller)	2-1, 2-2, 2-3
Input Modules	3-5
Master Program Enable	3-1
Motion Detection Output	3-1
Operator Program Enable	3-1
Output Group 1 Enable (Re-Zero Input)	3-1
Power Outputs (Modules)	3-4
Resolver	3-14
Re-Zero Input (Output Group 1 Enable)	3-1
Program Select Inputs	3-1
Transistor Outputs	3-7, 3-8, 3-9

Electro Cam Corp.

800-228-5487 (U.S.A. and Canada) • Web Site: www.electrocam.com • email: ecam@electrocam.com

PRINTED IN U.S.A

252 01/06