

SYSMAC CV-series CV500/CV1000/CV2000/CVM1 Programmable Controllers

Installation Guide

Revised October 1999

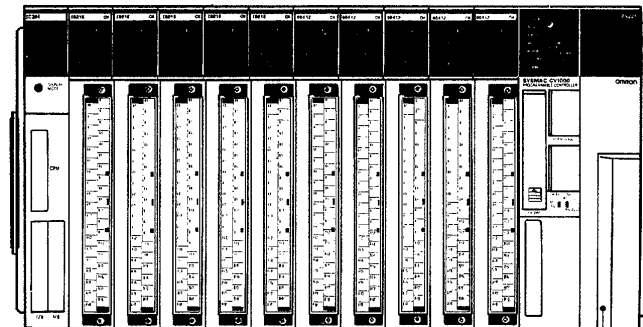



Notice:

OMRON products are manufactured for use according to proper procedures by a qualified operator and only for the purposes described in this manual.

The following conventions are used to indicate and classify precautions in this manual. Always heed the information provided with them. Failure to heed precautions can result in injury to people or damage to property.

 **DANGER** Indicates an imminently hazardous situation which, if not avoided, will result in death or serious injury.

 **WARNING** Indicates a potentially hazardous situation which, if not avoided, could result in death or serious injury.

 **Caution** Indicates a potentially hazardous situation which, if not avoided, may result in minor or moderate injury, or property damage.

OMRON Product References

All OMRON products are capitalized in this manual. The word “Unit” is also capitalized when it refers to an OMRON product, regardless of whether or not it appears in the proper name of the product.

The abbreviation “Ch,” which appears in some displays and on some OMRON products, often means “word” and is abbreviated “Wd” in documentation in this sense.

The abbreviation “PC” means Programmable Controller and is not used as an abbreviation for anything else.

Visual Aids

The following headings appear in the left column of the manual to help you locate different types of information.

Note Indicates information of particular interest for efficient and convenient operation of the product.

1, 2, 3... 1. Indicates lists of one sort or another, such as procedures, checklists, etc.

© OMRON, 1992

All rights reserved. No part of this publication may be reproduced, stored in a retrieval system, or transmitted, in any form, or by any means, mechanical, electronic, photocopying, recording, or otherwise, without the prior written permission of OMRON.

No patent liability is assumed with respect to the use of the information contained herein. Moreover, because OMRON is constantly striving to improve its high-quality products, the information contained in this manual is subject to change without notice. Every precaution has been taken in the preparation of this manual. Nevertheless, OMRON assumes no responsibility for errors or omissions. Neither is any liability assumed for damages resulting from the use of the information contained in this publication.

TABLE OF CONTENTS

PRECAUTIONS	
1 Intended Audience	
2 General Precautions	
3 Safety Precautions	
4 Operating Environment Precautions	
5 Application Precautions	
6 Conformance to EC Directives	
SECTION 1	
Introduction	
1-1 Control Systems	
1-2 The Role of the PC	
1-3 PC Operation	
1-4 CV-series Manuals	
1-5 C-series–CV-series System Compatibility	
1-6 Networks and Remote I/O Systems	
1-7 New CPUs and Related Units	
1-8 CPU Comparison	
1-9 Improved Specifications	
SECTION 2	
System Configuration and Components	
2-1 System Configuration	
2-2 Racks	
2-3 Rack Components	
SECTION 3	
Installation	
3-1 Assembly	
3-2 Installation Environment	
3-3 Mounting Racks	
3-4 Power Supply Units	
3-5 Wiring I/O Units	
3-6 Compliance with EC Directives	
SECTION 4	
Inspection and Maintenance	
4-1 CPU Battery	
4-2 Memory Card Battery	
4-3 Output Unit Fuses	
4-4 Output Unit Relays	
SECTION 5	
Troubleshooting	
5-1 Error Messages and Alarm Outputs	
5-2 Troubleshooting Flowcharts	
5-3 Error Processing and Correction	
Appendices	
A Standard Models	
B Specifications	
Glossary	
Index	
Revision History	

About this Manual:

This manual describes the installation of the SYSMAC CV-series Programmable Controllers (CV500, CV1000, CV2000, and CVM1). This manual is designed to be used together with three CV-series PC operation manuals. The entire set of CV-series PC manuals is listed below. Only the basic portions of the catalog numbers are given; be sure you have the most recent version for your area.

Manual	Cat. No.
CV-series PC Installation Guide	W195
CV-series PC Operation Manual: SFC	W194
CV-series PC Operation Manual: Ladder Diagrams	W202
CV-series PC Operation Manual: Host Interface	W205

Programming and operating CV-series PCs are performed with the CV Support Software (CVSS), the SYSMAC Support Software (SSS), and the CV-series Programming Console for which the following manuals are available.

Product	Manuals
CVSS	The CV Series Getting Started Guidebook (W203) and the CV Support Software Operation Manuals: Basics (W196), Offline (W201), and Online (W200).
SSS	SYSMAC Support Software Operation Manuals: Basics (W247), C-series PC Operations (W248), and CVM1 Operations (W249)
CV-series Programming Console	CVM1-PRS21-E Programming Console Operation Manual (W222)

Note The CVSS does not support new instructions added for version-2 CVM1 PCs. The SSS does not support SFC programming (CV500, CV1000, or CV2000).

Section 1 introduces programmable controllers in general and provides tables of the Units that can be used with CV-series PCs and operation manuals available for CV-series products. Special products used to create networks, enable remote I/O, or provide additional programming capabilities are also provided. Tables are also provided of new products included for the first time in this version of the manual, along with a comparison of CPU capabilities, and a list of improvements made in recent CPU versions.

Section 2 describes the overall configuration that the PC System can take and introduces the main Units used in the system configuration.

Section 3 provides procedures on installing and wiring.

Section 4 provides information on ongoing maintenance.

Section 5 describes general troubleshooting and provides troubleshooting flowcharts.

Appendix A provides tables of C- and CV-series products that can be used with CV-series PCs.

Appendix B provides general PC specifications, dimensions, and I/O Unit specifications (including internal circuit configurations and wiring diagrams).

	<p>WARNING Failure to read and understand the information provided in this manual may result in personal injury or death, damage to the product, or product failure. Please read each section in its entirety and be sure you understand the information provided in the section and related sections before attempting any of the procedures or operations given.</p>
---	---

PRECAUTIONS

This section provides general precautions for using the Programmable Controller (PC) and related devices.

The information contained in this section is important for the safe and reliable application of the Programmable Controller. You must read this section and understand the information contained before attempting to set up or operate a PC system.

1 Intended Audience	
2 General Precautions	
3 Safety Precautions	
4 Operating Environment Precautions	
5 Application Precautions	
6 Conformance to EC Directives	

1 Intended Audience

This manual is intended for the following personnel, who must also have knowledge of electrical systems (an electrical engineer or the equivalent).

- Personnel in charge of installing FA systems.
- Personnel in charge of designing FA systems.
- Personnel in charge of managing FA systems and facilities.

2 General Precautions

The user must operate the product according to the performance specifications described in the operation manuals.

Before using the product under conditions which are not described in the manual or applying the product to nuclear control systems, railroad systems, aviation systems, vehicles, combustion systems, medical equipment, amusement machines, safety equipment, and other systems, machines, and equipment that may have a serious influence on lives and property if used improperly, consult your OMRON representative.

Make sure that the ratings and performance characteristics of the product are sufficient for the systems, machines, and equipment, and be sure to provide the systems, machines, and equipment with double safety mechanisms.

This manual provides information for programming and operating the Unit. Be sure to read this manual before attempting to use the Unit and keep this manual close at hand for reference during operation.

 **WARNING** It is extremely important that a PC and all PC Units be used for the specified purpose and under the specified conditions, especially in applications that can directly or indirectly affect human life. You must consult with your OMRON representative before applying a PC System to the above-mentioned applications.

3 Safety Precautions

 **WARNING** Do not attempt to take any Unit apart while the power is being supplied. Doing so may result in electric shock.



 **WARNING** Do not touch any of the terminals or terminal blocks while the power is being supplied. Doing so may result in electric shock.

 **WARNING** Do not attempt to disassemble, repair, or modify any Units. Any attempt to do so may result in malfunction, fire, or electric shock.

 **WARNING** There is a lithium battery built into the SRAM Memory Cards. Do not short the positive and negative terminals of the battery, charge the battery, attempt to take it apart, subject it to pressures that would deform it, incinerate it, or otherwise mistreat it. Doing any of these could cause the battery to erupt, ignite, or leak.



 **Caution** Tighten the screws on the terminal block of the AC Power Supply Unit to the torque specified in the operation manual. The loose screws may result in burning or malfunction.

4 Operating Environment Precautions

-  **Caution** Do not operate the control system in the following places:
- Locations subject to direct sunlight.
 - Locations subject to temperatures or humidity outside the range specified in the specifications.
 - Locations subject to condensation as the result of severe changes in temperature.
 - Locations subject to corrosive or flammable gases.
 - Locations subject to dust (especially iron dust) or salts.
 - Locations subject to exposure to water, oil, or chemicals.
 - Locations subject to shock or vibration.
-  **Caution** Take appropriate and sufficient countermeasures when installing systems in the following locations:
- Locations subject to static electricity or other forms of noise.
 - Locations subject to strong electromagnetic fields.
 - Locations subject to possible exposure to radioactivity.
 - Locations close to power supplies.
-  **Caution** The operating environment of the PC System can have a large effect on the longevity and reliability of the system. Improper operating environments can lead to malfunction, failure, and other unforeseeable problems with the PC System. Be sure that the operating environment is within the specified conditions at installation and remains within the specified conditions during the life of the system.

5 Application Precautions

Observe the following precautions when using the PC System.

-  **WARNING** Always heed these precautions. Failure to abide by the following precautions could lead to serious or possibly fatal injury.
- Always ground the system to 100 Ω or less when installing the Units. Not connecting to a ground of 100 Ω or less may result in electric shock.
 - Always turn OFF the power supply to the PC before attempting any of the following. Not turning OFF the power supply may result in malfunction or electric shock.
 - Mounting or dismounting I/O Units, Memory Cassettes, or any other Units.
 - Setting switches.
 - Connecting cables or wiring the system.
 - Connecting or disconnecting the connectors.
-  **Caution** Failure to abide by the following precautions could lead to faulty operation of the PC or the system, or could damage the PC or PC Units. Always heed these precautions.
- Fail-safe measures must be taken by the customer to ensure safety in the event of incorrect, missing, or abnormal signals caused by broken signal lines, momentary power interruptions, or other causes.

- Interlock circuits, limit circuits, and similar safety measures in external circuits (i.e., not in the Programmable Controller) must be provided by the customer.
- Always use the power supply voltage specified in the operation manuals. An incorrect voltage may result in malfunction or burning.
- Take appropriate measures to ensure that the specified power with the rated voltage and frequency is supplied. Be particularly careful in places where the power supply is unstable. An incorrect power supply may result in malfunction.
- Install external breakers and take other safety measures against short-circuiting in external wiring. Insufficient safety measures against short-circuiting may result in burning.
- Do not apply voltages to the Input Units in excess of the rated input voltage. Excess voltages may result in burning.
- Do not apply voltages or connect loads to the Output Units in excess of the maximum switching capacity. Excess voltages or loads may result in burning.
- Disconnect the functional ground terminal when performing withstand voltage tests. Not disconnecting the functional ground terminal may result in burning.
- Install the Unit properly as specified in the operation manual. Improper installation of the Unit may result in malfunction.
- Be sure that all the mounting screws, terminal screws, and cable connector screws are tightened to the torque specified in the relevant manuals. Incorrect tightening torque may result in malfunction.
- Use crimp terminals for wiring. Do not connect bare stranded wires directly to terminals. Connection of bare stranded wires may result in burning.
- Double-check all the wiring before turning on the power supply. Incorrect wiring may result in burning.
- Be sure that the terminal blocks, Memory Units, expansion cables, and other items with locking devices are properly locked into place. Improper locking may result in malfunction.
- Check the user program for proper execution before actually running it on the Unit. Not checking the program may result in an unexpected operation.
- Confirm that no adverse effect will occur in the system before attempting any of the following. Not doing so may result in an unexpected operation.
 - Changing the operating mode of the PC.
 - Force-setting/force-resetting any bit in memory.
 - Changing the present value of any word or any set value in memory.
- Resume operation only after transferring to the new CPU Unit the contents of the DM Area, HR Area, and other data required for resuming operation. Not doing so may result in an unexpected operation.
- Do not pull on the cables or bend the cables beyond their natural limit. Doing either of these may break the cables.
- Do not place objects on top of the cables. Doing so may break the cables.

6 Conformance to EC Directives

The CV-series PCs that comply with EC Directives must be installed as follows:

- 1, 2, 3...** 1. The CV-series PCs are designed for installation inside control panels. The PC must be installed within a control panel.
2. Use reinforced insulation or double insulation for the DC power supplies to be connected to the DC I/O Units for CV500-PS211. Use separate power supplies as the external power supplies for the Relay Output Units and the power supplies for the DC I/O Units.
3. To meet the EC Directives (Low Voltage Directive), the maximum switching capacity while the CV500-PS211 is being operated is 24 VDC/2 A.

- PCs complying with EC Directives also conform to the Common Emission Standard (EN50081-2). When a PC is built into a machine, however, noise can be generated by switching devices using relay outputs and cause the overall machine to fail to meet the Standards. If this occurs, surge killers must be connected or other measures taken external to the PC.

The following methods represent typical methods for reducing noise, and may not be sufficient in all cases. Required countermeasures will vary depending on the devices connected to the control panel, wiring, the configuration of the system, and other conditions.

Countermeasures

Refer to EN50081-2 for more details.

Countermeasures are not required if the frequency of load switching for the whole system including the PC is less than 5 times per minute.

Countermeasures are required if the frequency of load switching for the whole system including the PC is 5 or more times per minute.

Countermeasure Examples

When switching an inductive load, connect a surge protector, diodes, etc., in parallel with the load or contact as shown below.

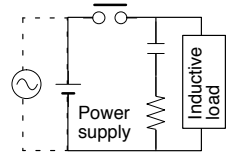
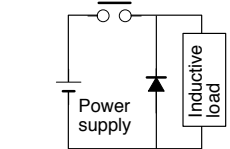
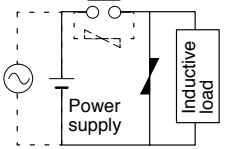
Circuit	Current		Characteristic	Required element
	AC	DC		
<p>CR method</p> 	Yes	Yes	<p>If the load is a relay or solenoid, there is a time lag between the moment the circuit is opened and the moment the load is reset.</p> <p>If the supply voltage is 24 or 48 V, insert the surge protector in parallel with the load. If the supply voltage is 100 to 200 V, insert the surge protector between the contacts.</p>	<p>The capacitance of the capacitor must be 1 to 0.5 μF per contact current of 1 A and resistance of the resistor must be 0.5 to 1 Ω per contact voltage of 1 V. These values, however, vary with the load and the characteristics of the relay. Decide these values from testing, and take into consideration that the capacitance suppresses spark discharge when the contacts are separated and the resistance limits the current that flows into the load when the circuit is closed again.</p> <p>The dielectric strength of the capacitor must be 200 to 300 V. If the circuit is an AC circuit, use a capacitor with no polarity.</p>
<p>Diode method</p> 	No	Yes	<p>The diode connected in parallel with the load changes energy accumulated by the coil into a current, which then flows into the coil so that the current will be converted into Joule heat by the resistance of the inductive load.</p> <p>This time lag, between the moment the circuit is opened and the moment the load is reset, caused by this method is longer than that caused by the CR method.</p>	<p>The reversed dielectric strength value of the diode must be at least 10 times as large as the circuit voltage value. The forward current of the diode must be the same as or larger than the load current.</p> <p>The reversed dielectric strength value of the diode may be two to three times larger than the supply voltage if the surge protector is applied to electronic circuits with low circuit voltages.</p>
<p>Varistor method</p> 	Yes	Yes	<p>The varistor method prevents the imposition of high voltage between the contacts by using the constant voltage characteristic of the varistor. There is time lag between the moment the circuit is opened and the moment the load is reset.</p> <p>If the supply voltage is 24 or 48 V, insert the varistor in parallel with the load. If the supply voltage is 100 to 200 V, insert the varistor between the contacts.</p>	---

When switching a load with a high inrush current such as an incandescent lamp, suppress the inrush current as shown below.

Countermeasure 1

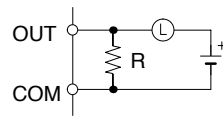

Providing a dark current of approx. one-third of the rated value through an incandescent lamp

Countermeasure 2

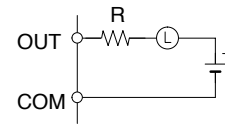

Providing a limiting resistor

SECTION 1

Introduction

This section provides general information about Programmable Controllers and how they fit into a Control System. It also lists the C-series products that can be used with the CV-series PCs and operation manuals available for CV-series products. Finally, this section introduces Systems that can be used to create networks and enable remote I/O.

1-1	Control Systems	
1-2	The Role of the PC	
1-2-1	Input Devices	
1-2-2	Output Devices	
1-3	PC Operation	
1-4	CV-series Manuals	
1-5	C-series–CV-series System Compatibility	
1-6	Networks and Remote I/O Systems	
1-7	New CPUs and Related Units	
1-8	CPU Comparison	
1-9	Improved Specifications	
1-9-1	Upgraded Specifications	
1-9-2	Version-1 CPUs	
1-9-3	Version-2 CVM1 PCs	

1-1 Control Systems

A Control System is the electronic equipment needed to control a particular process. It may include everything from a process control computer, to the factory computer, down through the PCs, and then on down through the network to the I/O devices: control components like the switches, stepping motors, solenoids, and sensors which monitor and control mechanical operations.

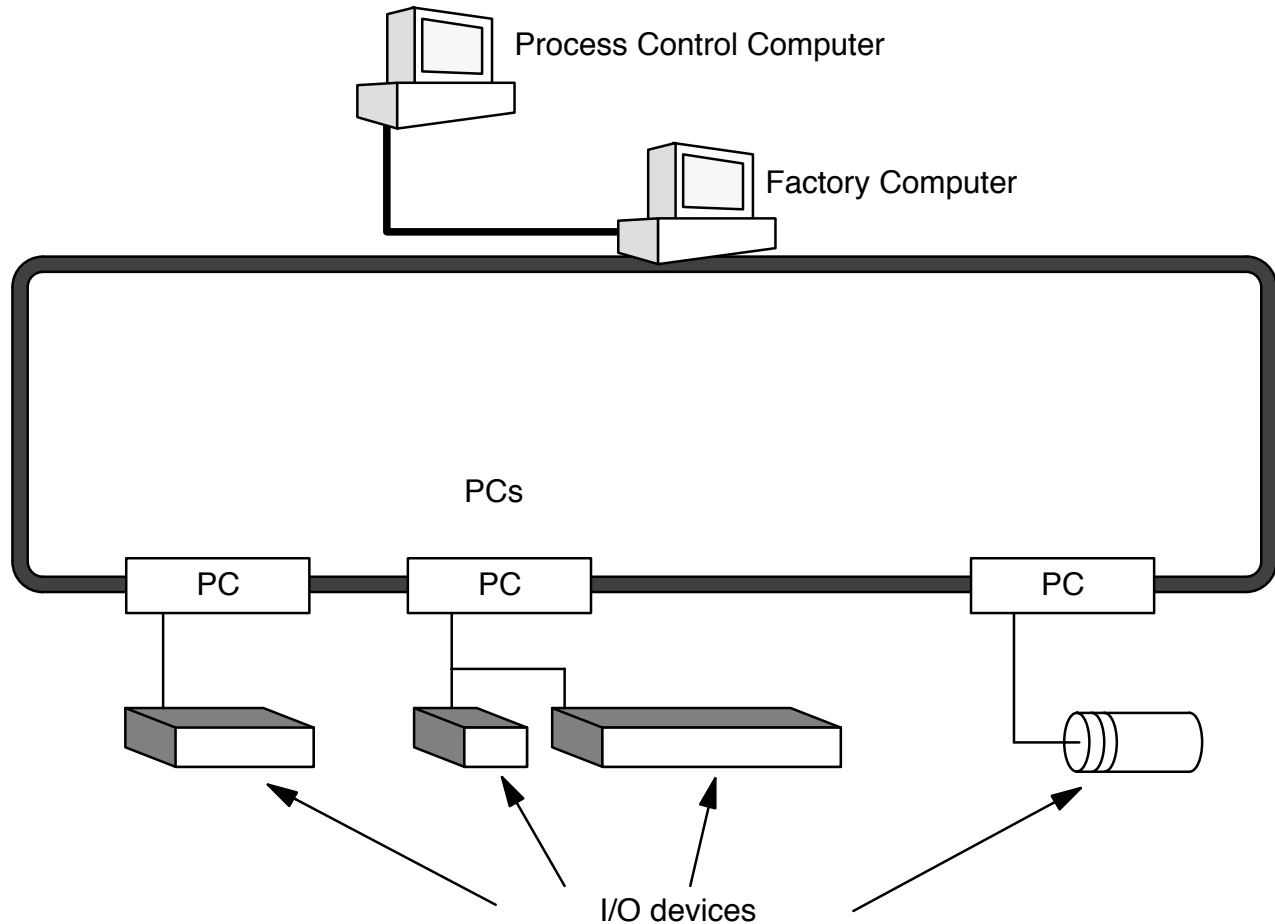

A Control System can involve very large applications where many different models of PC are networked together or it could be an application as small as a single PC controlling a number of output devices.

1-2 The Role of the PC

The PC is the part of the Control System that directly controls the manufacturing process. According to the program stored in its memory, the PC accepts data from the input devices connected to it and uses this data to monitor the controlled system. When the program calls for some action to take place, the PC sends data to the output devices connected to it to cause that action to take place. The PC may be used to control a simple, repetitive task, or it may be connected to other PCs or to a host computer in order to integrate the control of a complex process.

1-2-1 Input Devices

PCs can receive inputs from either automated or manual devices. The PC could receive data from the user via a pushbutton switch, keyboard, or similar device. Automated inputs could come from a variety of devices: micro-switches, timers, encoders, photoelectric sensors, and so on. Some devices, like the limit switch shown below, turn ON or OFF when the equipment actually makes contact with them. Other devices, like the photoelectric sensor and proximity sensor shown below, use other means, such as light or inductance, in order to get information about the equipment being monitored.

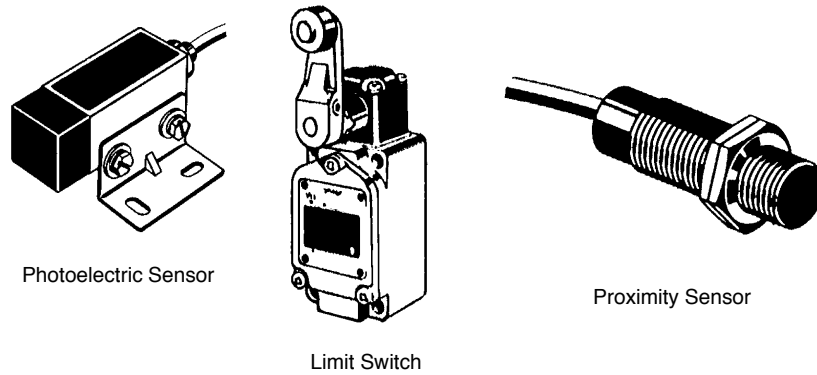

1-2-2 Output Devices

A PC can output to a myriad of devices for use in automated control. Almost anything that you can think of could be controlled by a PC. Some of the most common devices are motors, solenoids, servomotors, stepping motors, valves, switches, indicator lights, buzzers, and alarms. Some of these output devices, such as the motors, solenoids, servomotors, stepping motors, and valves, affect the controlled system directly. Others, such as the indicator lights, buzzers, and alarms, provide outputs to notify personnel operating or monitoring the system.

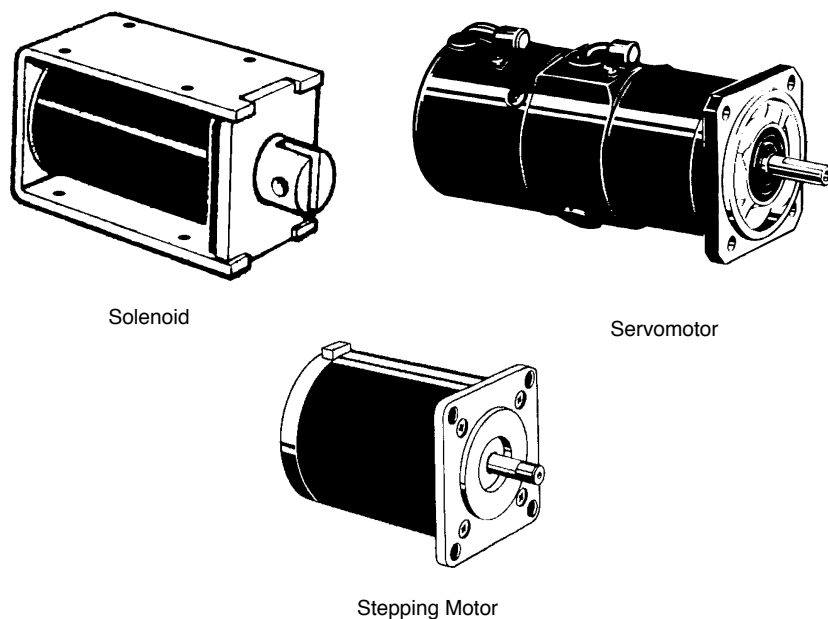

1-3 PC Operation

PCs operate by monitoring input signals and providing output signals. When changes are detected in input signals, the PC reacts through the user-programmed internal logic to produce output signals. The PC continually executes the program in its memory to achieve this control.

Block Diagram of PC

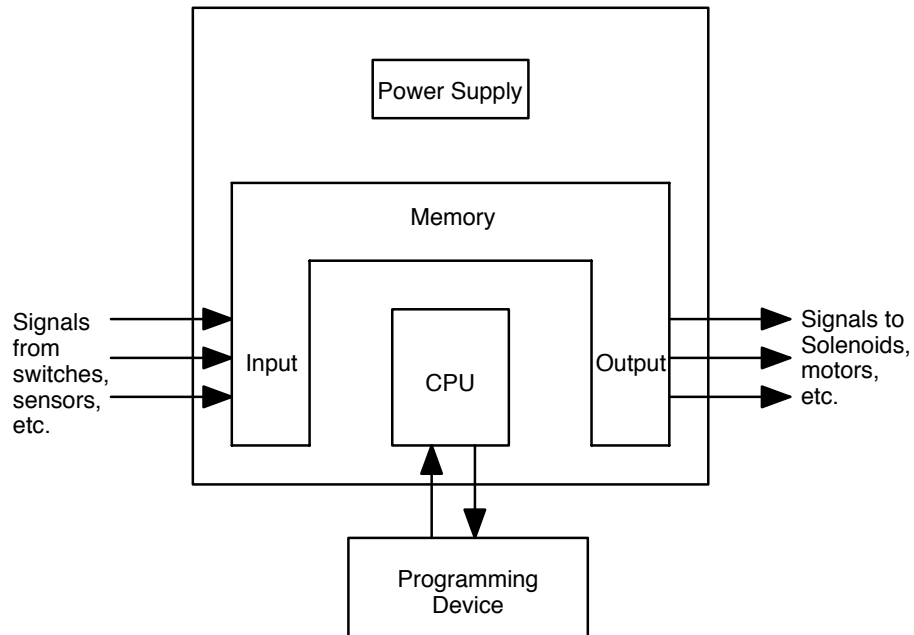

A program for your applications must be designed and stored in the PC. This program is then executed as part of the cycle of internal operations of the PC.

Execution Cycle

When a PC operates, i.e., when it executes its program to control an external system, a series of operations are performed inside the PC. These internal operations can be broadly classified into the following four categories. Refer to the *CV-series PCs Operation Manual: Ladder Diagrams* for details.

- 1, 2, 3...**
 1. Common (or overseeing) processes, such as watchdog timer operation and testing the program memory.
 2. Data input and output.
 3. Program execution.
 4. Peripheral device servicing.

Cycle Time

The total time required for a PC to perform all these internal operations is called the cycle time.

Timing is one of the most important factors in designing a Control System. For accurate operations, it is necessary to have answers to such questions as these:

- How long does it take for the PC to execute all the instructions in its memory?
- How long does it take for the PC to produce a control output in response to a given input signal?

The cycle time of the PC can be automatically calculated and monitored, but it is necessary to have an understanding of the timing relationships within the PC for effective System design and programming. Refer to the *CV-series PCs Operation Manual: Ladder Diagrams* for details on internal PC processing and to the *CVSS Operation Manuals* for details on monitoring the cycle time.

1-4 CV-series Manuals

The following manuals are available for the various CV-series products. Other manuals are also available for compatible C-series products (see next section). Catalog number suffixes have been omitted; be sure you have the most recent version for your region.

Product	Manual	Cat. No.
CV-series PCs	CV-series PCs Installation Guide	W195
	CV-series PCs Operation Manual: SFC	W194
	CV-series PCs Operation Manual: Ladder Diagrams	W202
	CV-series PCs Operation Manual: Host Link System, CV500-LK201 Host Link Unit	W205
CV Support Software (CVSS)	The CV Series Getting Started Guidebook	W203
	CV Support Software Operation Manual: Basics	W196
	CV Support Software Operation Manual: Offline	W201
	CV Support Software Operation Manual: Online	W200
SYSMAC Support Software (SSS)	SYSMAC Support Software Operation Manual: Basics	W247
	SYSMAC Support Software Operation Manual: CVM1 PCs	W249
Graphic Programming Console (GPC)	CV500-MP311-E Graphic Programming Console Operation Manual	W216
Programming Console	CVM1-PRS21-E Programming Console Operation Manual	W222
SYSMAC NET Link System	SYSMAC NET Link System Manual	W213
SYSMAC LINK System	SYSMAC LINK System Manual	W212
SYSMAC BUS/2 Remote I/O System	SYSMAC BUS/2 Remote I/O System Manual	W204
CompoBus/D (DeviceNet)	CompoBus/D (DeviceNet) Operation Manual	W267
CV-series Ethernet Unit	CV-series Ethernet System Manual	W242
BASIC Unit	BASIC Unit Reference Manual	W207
	BASIC Unit Operation Manual	W206
Personal Computer Unit	Personal Computer Unit Operation Manual	W251
	Personal Computer Unit Technical Manual	W252
Motion Control Unit	Motion Control Unit Operation Manual: Introduction	W254
	Motion Control Unit Operation Manual: Details	W255
Temperature Controller Data Link Unit	CV500-TDL21 Temperature Controller Data Link Unit	W244
Memory Card Writer	CV500-MCW01-E Memory Card Writer Operation Manual	W214
Optical Fiber Cable	Optical Fiber Cable Installation Guide	W156

1-5 C-series–CV-series System Compatibility

The following table shows when C-series Units can be used and when CV-series Units must be used. Any C-series Unit or Peripheral Device not listed in this table cannot be used with the CV-series PCs.

Unit		C Series	CV Series	Remarks
CPU Rack	CPU	No	Yes	CV500-CPU01-EV1, CV1000-CPU01-EV1, CV2000-CPU01-EV1, CVM1-CPU01-EV2, CVM1-CPU11-EV2, and CVM1-CPU21-EV2
	Power Supply	No	Yes	CV500-PS221, CV500-PS211, and CVM1-PA208
	CPU Backplane	No	Yes	CV500-BC031, CV500-BC051, CV500-BC101, CVM1-BC103, and CVM1-BC053
	I/O Control Unit	No	Yes	CV500-IC□01
Expansion CPU Backplane		No	Yes	CV500-BI111
Expansion I/O Backplane		No	Yes	CV500-BI042, CV500-BI062, CV500-BI112, CVM1-BI114, and CVM1-BI064 (C500 Expansion I/O Racks can be used with certain limitations.)
16-/32-/64-point I/O Units		Yes	Yes	---
Special I/O Units		Yes	Yes	Applicable Units include Analog Input, Analog Output, High-speed Counter, PID, Position Control, Magnetic Card, ASCII, ID Sensor, and Ladder Program I/O Units (The C500-ASC03 cannot be used.)
BASIC Unit		No	Yes	CV500-BSC□1
Personal Computer Unit		No	Yes	CV500-VP213-E/217-E/223-E/227-E
Temperature Control Data Link Unit		No	Yes	CV500-TDL21
Link Systems	SYSMAC NET	No	Yes	CV500-SNT31
	SYSMAC LINK	No	Yes	CV500-SLK11 and CV500-SLK21
	Host Link Unit	No	Yes	CV500-LK201
	Ethernet Unit	No	Yes	CV500-ETN01
Remote I/O Systems	SYSMAC BUS Units	Yes	Yes	---
	SYSMAC BUS/2	No	Yes	CV500-RM211/221 and CV500-RT211/221
Peripheral Devices	CV Support Software	No	Yes (See note.)	CV500-ZS3AT1-EV2 (3 1/2" floppy disks) and CV500-ZS5AT1-EV2 (5 1/4" floppy disks) for IBM PC/AT compatible
	SYSMAC Support Software (SSS)	Yes	Yes (See note.)	C500-ZL3AT1-E (3.5" floppy disks) for IBM PC/AT compatible
	Graphic Programming Console	Yes (Main unit only)	Yes (System Cassette) (See note.)	GPC: 3G2C5-GPC03-E System Cassette: CV500-MP311-E
	Programming Console	No	Yes (See note.)	CVM1-PRS21-EV1 (set)

Note The CVSS does not support new instructions added for version-2 CVM1 PCs. The SSS does not support SFC programming (CV500, CV1000, and CV2000). New instructions added for version-2 CVM1 PCs are also supported by version-1 CV-series Programming Consoles.

1-6 Networks and Remote I/O Systems

Systems that can be used to create networks and enable remote I/O are introduced in this section. Refer to the operation manuals for the Systems for details.

SYSMAC NET Link System

The SYSMAC NET Link System is a LAN (local area network) for use in factory automation systems. The SYSMAC NET Link System can consist of up to 128 nodes among which communications may be accomplished via datagrams, data transfers, or automatic data links.

Datagrams transmit and receive data using a command/response format. Commands can be issued from the user program by the DELIVER COMMAND instruction (CMND(194)).

Data can also be transmitted and received using the NETWORK SEND and NETWORK RECEIVE (SEND(192)/RECV(193)) instructions in the user program. Up to 256 words of data can be transferred for each instruction.

Automatic data links allow PCs and computers to create common data areas.

SYSMAC NET Link Unit
CV500-SNT31

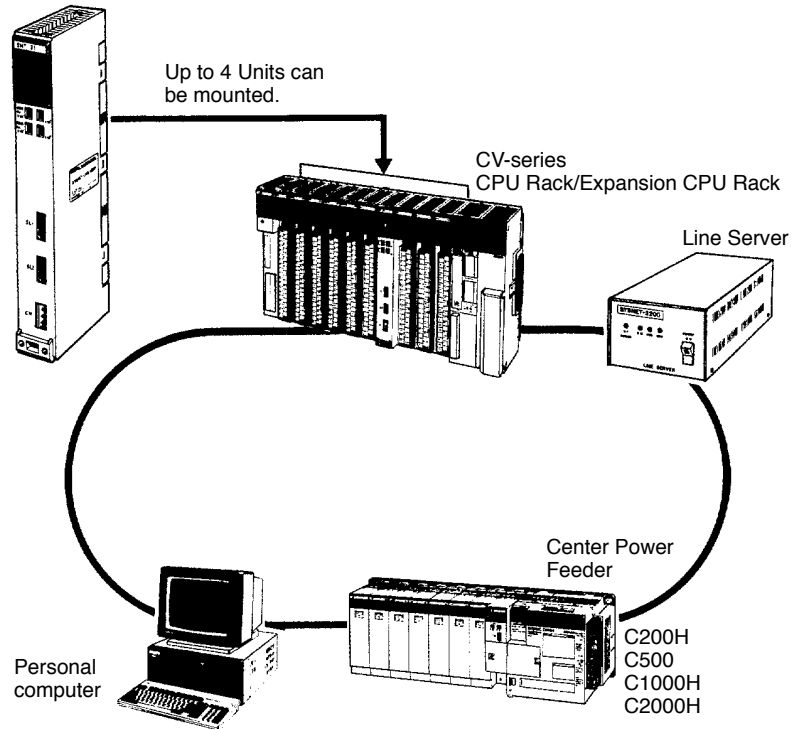

Note Up to four SYSMAC NET Link Units (CV500-SNT31) can be mounted to the CPU Rack and/or Expansion CPU Rack of each CV-series PC.

SYSMAC LINK System

Networks can also be created using SYSMAC LINK Systems. A SYSMAC LINK System can consist of up to 62 PCs, including the CV500, CV1000, CV2000, CVM1, C200H, C1000H, and C2000H. Communications between the PCs is accomplished via datagrams, data transfers, or automatic data links in ways similar to the SYSMAC NET Link System.

The main differences between SYSMAC NET Link and SYSMAC LINK Systems is in the structure of automatic data links and in the system configuration, e.g., only PCs can be linked in SYSMAC LINK Systems, whereas other devices can form nodes in SYSMAC NET Link Systems.

Datagrams transmit and receive data using a command/response format. Commands can be issued from the user program by the DELIVER COMMAND instruction (CMND(194)).

Data can also be transmitted and received using the NETWORK SEND and NETWORK RECEIVE (SEND(192)/RECV(193)) instructions in the user program. Up to 256 words of data can be transferred for each instruction.

Automatic data links allow PCs and computers to create common data areas.

SYSMAC LINK Unit
 CV500-SLK11 (optical)
 CV500-SLK21 (wired)

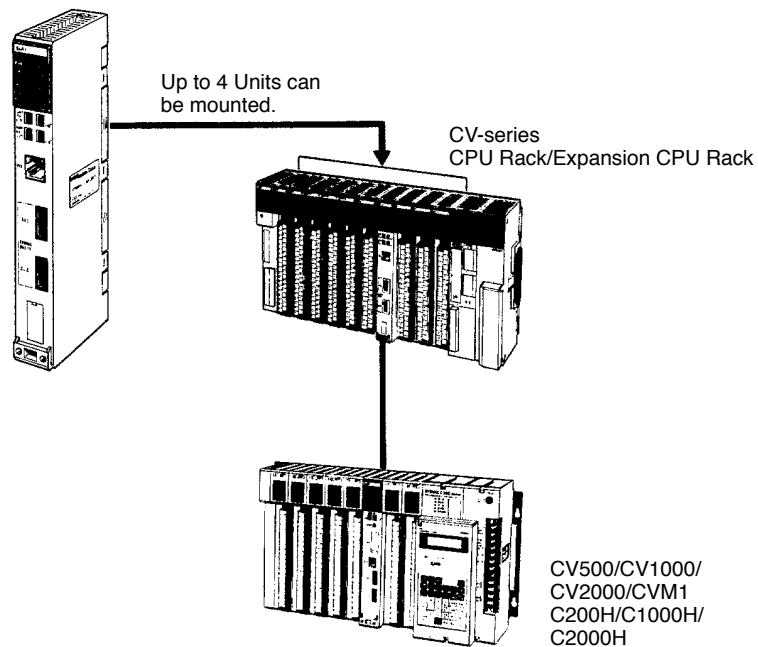

Note Up to four SYSMAC LINK Units (CV500-SLK11/21) can be mounted the CPU Rack and/or Expansion CPU Rack of each CV-series PC.

SYSMAC BUS/2 Remote I/O System

Remote I/O can be enabled by adding a SYSMAC BUS/2 Remote I/O System to the PC. The SYSMAC BUS/2 Remote I/O System is available in two types: optical and wired.

Two Remote I/O Master Units, optical or wired, can be mounted to the CV500 or CVM1-CPU01-EV2 CPU Rack or Expansion CPU Rack. Four Remote I/O Master Units can be mounted to the CV1000, CV2000, or CVM1-CPU11/21-EV2 CPU Rack or Expansion CPU Rack.

Up to eight Remote I/O Slave Racks can be connected per PC.

Slaves can be used to provide up to 1,024 remote I/O points for the CV500 or CVM1-CPU01-EV2; up to 2,048 remote I/O points for the CV1000, CV2000, or CVM1-CPU11/21-EV2. These limits are the totals for all Slaves control by one PC.

A Programming Device (such as the CVSS) can be connected to up to two Remote I/O Slave Units for each Remote I/O Master Unit as long as a total of no more than four Programming Devices are connected per PC.

Remote I/O Master Unit
 CV500-RM211 (optical)
 CV500-RM221 (wired)

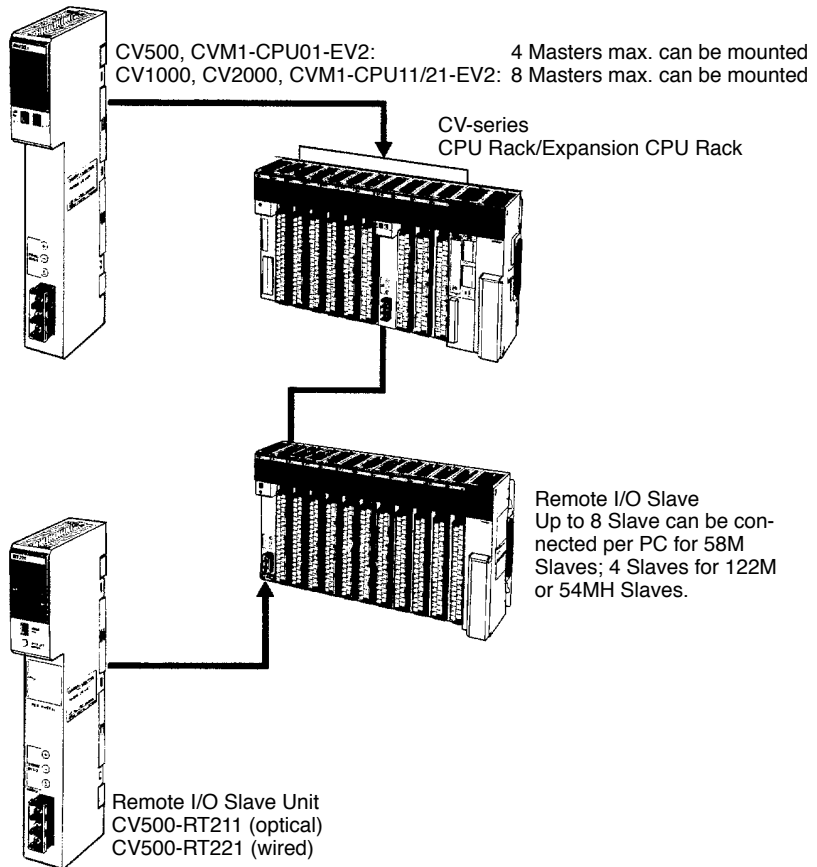

SYSMAC BUS Remote I/O System

Remote I/O can also be enabled by using the C-series SYSMAC BUS Remote I/O System with CV-series PC.

Remote I/O Master Units can be mounted on any slot of the CPU Rack, Expansion CPU Rack, or Expansion I/O Rack. Up to four Masters can be mounted for the CV500 or CVM1-CPU01-EV2, up to eight Masters for the CV1000, CV2000, or CVM1-CPU11/21-EV2.

For each Master, up to two Slave Racks can be connected for the CV500 or CVM1-CPU01-EV2; up to eight Slave Racks for the CV1000, CV2000, or CVM1-CPU11/21-EV2. No more than 16 Slave Racks can be connected per PC.

Slaves can be used to provide up to 512 remote I/O points for the CV500 or CVM1-CPU01-EV2; up to 1,024 remote I/O points for the CV1000, CV2000, or CVM1-CPU11-EV2; up to 2,048 remote I/O points for the CVM1-CPU21-EV2. These limits are the totals for all Slaves control by one PC.

Programming Devices cannot be connected to SYSMAC BUS Slave Racks.

Remote I/O Master Unit
 3G2A5-RM001-(P)EV1 (optical)
 C500-RM201 (wired)

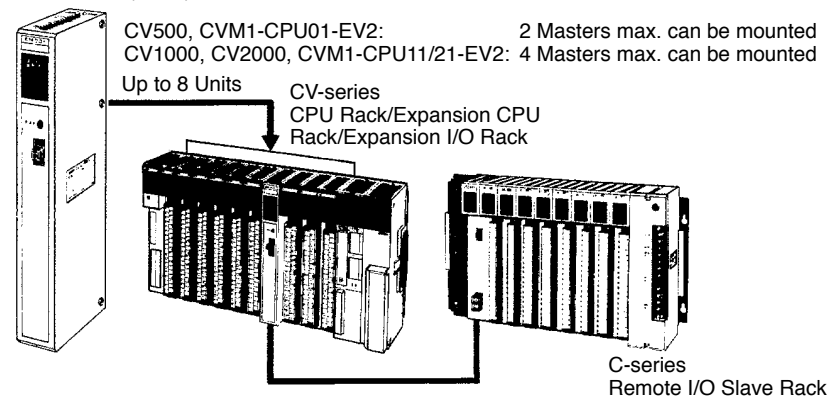

Host Link System (SYSMAC WAY)

The CV-series PCs can be connected to a host computer with the host link connector via the CPU or a CV500-LK201 Host Link Unit mounted to a Rack.

RS-232C or RS-422 communications can be used depending on the switch setting. When RS-422 is selected, up to 32 PCs can be connected to a single host. Data is transmitted and received by commands and responses.

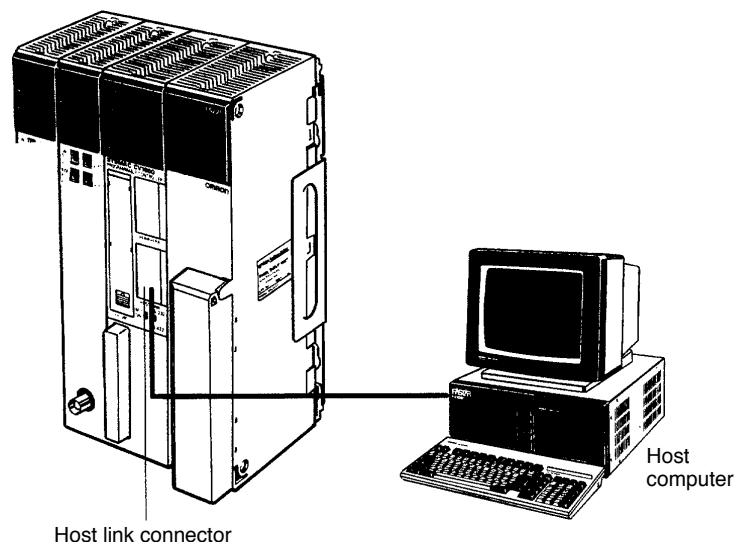

BASIC Unit

The BASIC Unit can be connected to a personal computer to enable communications with the PC using the BASIC programming language. Up to 512 bytes (256 words) of data can be transferred between the BASIC Unit and the CPU by the PC READ/WRITE command without using the PC program.

Up to 256 words of data can also be transferred between the BASIC Unit and the PC's CPU by using the NETWORK SEND and NETWORK RECEIVE (SEND(192)/RCV(193)) instructions in the PC program.

Data can also be transferred to other BASIC Units mounted on the same PC, or to BASIC Units mounted to other PCs connected by networks formed using a SYSMAC NET Link or SYSMAC LINK System. RS-232C, RS-422, Centronics, and GPIB interfaces are available.

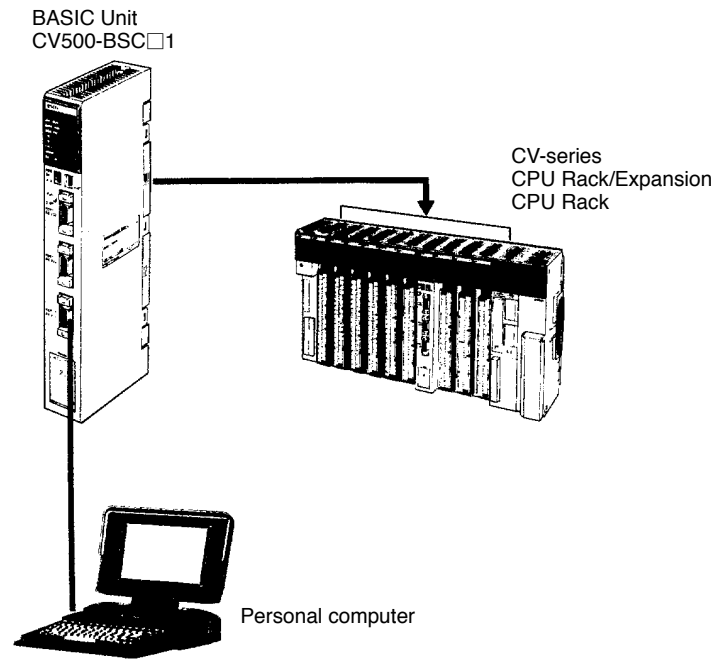

Personal Computer Unit

The Personal Computer Unit is a full-fledged IBM PC/AT compatible that can be used to run independent programming directly on a Rack to eliminate the need for separate installation space. It can run along or connected to any of the normal peripherals supported by IBM PC/AT compatibles (mice, keyboards, monitors, data storage devices, etc.), and as a CPU Bus Unit, the Personal Computer Unit interfaces directly to the PC's CPU through the CPU bus to eliminate the need for special interface hardware, protocols, or programming.

1-7 New CPUs and Related Units

The following new CV-series CPUs and related Units are included in this version of the manual for the first time. Refer to relevant sections of this manual or the *CV-series PC Operation Manual: Ladder Diagrams* for further details.

Unit	Model number	Main specifications
CPU	CVM1-CPU01-EV2	I/O capacity: 512 pts; Ladder diagrams only
	CVM1-CPU11-EV2	I/O capacity: 1,024 pts; Ladder diagrams only
	CVM1-CPU21-EV2	I/O capacity: 2,048 pts; Ladder diagrams only
	CV500-CPU01-EV1	I/O capacity: 512 pts; Ladder diagrams or SFC + ladder diagrams
	CV1000-CPU01-EV1	I/O capacity: 1,024 pts; Ladder diagrams or SFC + ladder diagrams
	CV2000-CPU01-EV1	I/O capacity: 2,048 pts; Ladder diagrams or SFC + ladder diagrams
Temperature Controller Data Link Unit	CV500-TDL21	Connects up to 64 temperature control devices via 2 ports.

1-8 CPU Comparison

The following table shows differences between the various CV-series CPUs.

CPU		CVM1-CPU01-EV2	CVM1-CPU11-EV2	CVM1-CPU21-EV2	CV500-CPU01-EV1	CV1000-CPU01-EV1	CV2000-CPU01-EV1
Programming	Ladder diagrams	Supported	Supported	Supported	Supported	Supported	Supported
	SFC	Not supported	Not supported	Not supported	Supported	Supported	Supported
	Instructions	284	284	285	169	170	170
Speed	Basic instructions (ms)	0.15 to 0.45	0.125 to 0.375	0.125 to 0.375	0.15 to 0.45	0.125 to 0.375	0.125 to 0.375
	Other instructions (ms)	0.6 to 9.9	0.5 to 8.25	0.5 to 8.25	0.6 to 9.9	0.5 to 8.25	0.5 to 8.25
Program capacity (see note)		30K words	30K words	62K words	30K words	62K words	62K words
Local I/O capacity		512 pts	1,024 pts	2,048 pts	512 pts	1,024 pts	2,048 pts
Remote I/O capacity	SYSMAC BUS/2	1,024 pts	2,048 pts	2,048 pts	1,024 pts	2,048 pts	2,048 pts
	SYSMAC BUS	512 pts	1,024 pts	2,048 pts	512 pts	1,024 pts	1,024 pts
DM Area		8K words	24K words	24K words	8K words	24K words	24K words
Expansion DM Area		Not supported	Not supported	32K words each for 8 banks	Not supported	32K words each for 8 banks	32K words each for 8 banks
Timers		512	1,024	1,024	512	1,024	1,024
Counters		512	1,024	1,024	512	1,024	1,024
SFC steps		None	None	None	512	1,024	1,024
Step Flags		None	None	None	512	1,024	1,024
Transition Flags		None	None	None	512	1,024	1,024

Note The useable program capacity is 28K words or 60K words.

1-9 Improved Specifications

1-9-1 Upgraded Specifications

The following improvements are applicable to all CV500-CPU01-E and CV1000-CPU01-E CPUs with lot numbers in which the rightmost digit is 3 (□□□3) or higher.

- 1, 2, 3... 1. The MLPX(110) (4-TO-16 DECODER) instruction has been improved to also function as a 8-to-256 decoder and the DMPX(111) (16-TO-4 ENCODER) instruction has been improved to also function as a 256-to-8 encoder. To enable this improvement, the digit designator (Di) has been changed as shown below.

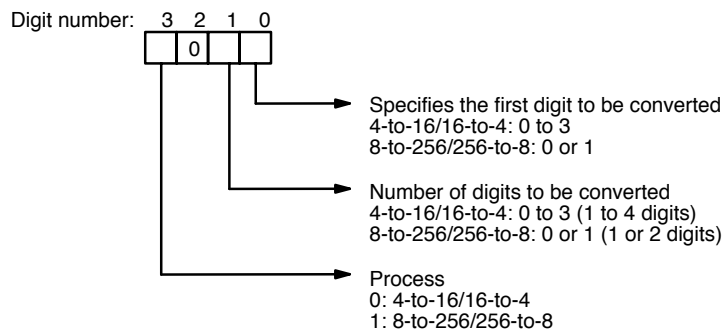

2. The following operating parameter has been added to the PC Setup.

JMP(004) 0000 Processing
 Y: Enable multiple usage (default)
 N: Disable multiple usage

3. The operation of Completion Flags for timers has been changed so that the Completion Flag for a timer turns ON only when the timer instruction is executed with a PV of 0000 and not when the timer's PV is refreshed to a PV value of 0000, as was previously done.

Only the timing of the activation of the Completion Flag has been changed, and the timer's PV is still refreshed at the same times (i.e., when the timer instruction is executed, at the end of user program execution, and every 80 ms if the cycle time exceeds 80 ms).

4. The READ(190) (I/O READ) and WRIT(191) (I/O WRITE) instructions have been improved so that they can be used for Special I/O Units on Slave Racks under the following conditions.
 - a) The lot number of the Remote I/O Master Unit and Remote I/O Slave Unit must be the same as or latter than the following.

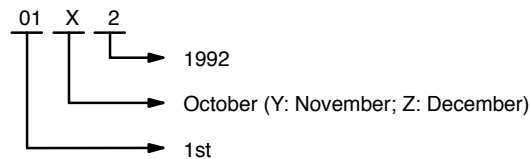

- b) The DIP switch on the Remote I/O Slave Unit must be set to "54MH."
 - c) The Special I/O Unit must be one of the following: AD101, CT012, CT021, CT041, ASC04, IDS01-V1, IDS02, IDS21, IDS22, or LDP01-V1. (The NC221-E, NC222, CP131, and FZ001 cannot be mounted to Slave Racks.)

1-9-2 Version-1 CPUs

CV-series CPUs were changed to version 1 from December 1993. The new model numbers are as follows: CVM1-CPU01-EV1, CVM1-CPU11-EV1, CV500-CPU-EV1, CV1000-CPU-EV1, and CV2000-CPU-EV1. (Of these, all CVM1 CPUs were changed to version 2 from December 1994; refer to the next sections for details.)

The following additions and improvements were made to create the version-1 CPUs.

PT Link Function

The host link interface on the CPU can be used to connect directly to Programmable Terminals (PTs) to create high-speed data links. To use the PT links, turn ON pin 3 of the DIP switch on the CPU. Pin 3 must be turned OFF for host link connections.

EEPROM Writes

With the new CPUs, you can write to EEPROM Memory Cards mounted to the CPU by using the file write operation from a Peripheral Device. A Memory Card Writer is no longer required for this write operation. Writing is possible in PROGRAM mode only.

New Command

A new I/O REGISTER command (QQ) has been added so that words from different data areas can be read at the same time.

Faster Host Links

The communications response time for the built-in host link interface on the CPU has been improved by a factor of approximately 1.2.

Faster Searches

The search speed from Peripheral Devices for instructions and operands has been nearly doubled.

1-9-3 Version-2 CVM1 PCs

CVM1 CPUs were changed to version 2 and a new CPU was added from December 1994. The new model numbers are as follows: CVM1-CPU01-EV2, CVM1-CPU11-EV2, and CVM1-CPU21-EV2.

The following additions and improvements were made to create the version-2 CPUs.

CMP/CMPL New versions of the CMP(020) and CMPL(021) have been added that are not intermediate instructions. The new instructions are CMP(028) and CMPL(029) and are programs as right-hand (final) instructions. A total of 24 other new comparison instructions have also been added with symbol mnemonics (e.g., >, +, and <).

XFER(040) This instruction has been upgraded so that source and destination areas can overlap.

DMPX(111) This instruction has been upgraded so that either the MSB or the LSB can be specified for use as the end code. Previously only the the MSB could be used.

New Flags Underflow and Overflow Flags have been added at A50009 and A50010, respectively. These flags can be turned ON or OFF when executing ADB, ADBL, SBB, and SBBL and can be saved or loaded using CCL and CCS.

New Instructions A total of 125 new instructions have been added. These instructions are supported by version-2 CPUs only.

Faster Online Editing The time that operation is stopped for online editing has been reduced and is no longer added to the cycle time. The following are just a couple of examples.

Edit	Time operation is stopped
Adding or deleting one instruction block at the beginning of a 62K-word program	Approx. 0.5 s
Deleting an instruction block containing JME from the beginning of a 62K-word program	Approx. 2.0 s

The above speed increase also applies to all V1 CPUs with lot numbers in which the rightmost digit is 5 (□□□5) or higher.

New Host Link Commands New C-mode commands for the CPU Host Interface have been added and the functionality of existing commands has been improved as follows:

New Commands

- RL/WL: Read and write commands for the CIO Area.
- RH/WH: Read and write commands for the CIO Area.
- CR: Read command for the DM Area.
- R#/R\$/R%: SV read commands.
- W#/W\$/W%: SV change commands.
- *: Initialization command.

Improved Commands

- The Link Area (CIO 1000 to CIO 1063) and Holding Area (CIO 1200 to CIO 1299) can now be specified for the KS, KR, KC, and QQ commands.
- CVM1-CPU21-EV2 can now be read for the MM command.

The above new and improved commands can also be used with all V1 CPUs with lot numbers in which the rightmost digit is 5 (□□□5) or higher.

Note Only the following Programming Devices support version-2 CPUs: SSS (C500-ZL3AT1-E) and the CVM1-PRS21-EV1 Programming Console (CVM1-MP201-V1). Of these, the SSS does not support SFC and thus cannot be used for the CV500, CV1000, and CV2000. Use the CVSS for these PCs.

SECTION 2

System Configuration and Components

This section provides information about the types of system configuration in which the CV-series PCs can be used and the individual Units that make up these configuration. Refer to *Appendix A Standard Models* for a list of C- and CV-series products that can be used in CV-series PC Systems.

- 2-1 System Configuration
- 2-2 Racks
- 2-2-1 CPU Racks
- 2-2-2 Expansion CPU Racks
- 2-2-3 Expansion I/O Racks
- 2-3 Rack Components
- 2-3-1 CPUs
- 2-3-2 I/O Control Units
- 2-3-3 I/O Interface Units
- 2-3-4 Power Supply Units
- 2-3-5 Termination Resistance Units
- 2-3-6 I/O Units

2-1 System Configuration

This section provides illustrations of CV-series PC Systems, which can be classified into five different types of configuration.

- Systems with only a CPU Rack
- Systems with only CV-series Expansion I/O Racks.
- Systems with an Expansion CPU Rack.
- Systems with a Single CV-series Expansion I/O Rack.
- Systems with C500 Expansion I/O Racks.

If only a CPU Rack is used, an I/O Control Unit is not required, but the CPU Rack is otherwise the same as those in the following examples. The specific Units used in the configuration are described in more detail later.

The maximum I/O capacity with any configuration is 512 points (32 words) for the CV500 or CVM1-CPU01-EV2; 1,024 points (64 words) for the CV1000 or CVM1-CPU11-EV2; and 2,048 points (128 words) for the CV2000 or CVM1-CPU21-EV2. The I/O capacity will be less depending on the Racks and the types of Units mounted.

Systems with only CV-series Expansion I/O Racks

The following figure shows an assembled CV-series CPU Rack and seven Expansion I/O Racks. Up to seven Expansion I/O Racks may be connected in one or two series from the CPU Rack. The total length of I/O Connecting Cable must be 50 m or less for each series and a Termination Resistance Unit must be connected to the last Rack or to the unused I/O Control Unit connector.

Units can be mounted to any slot on the Racks shown for them below.

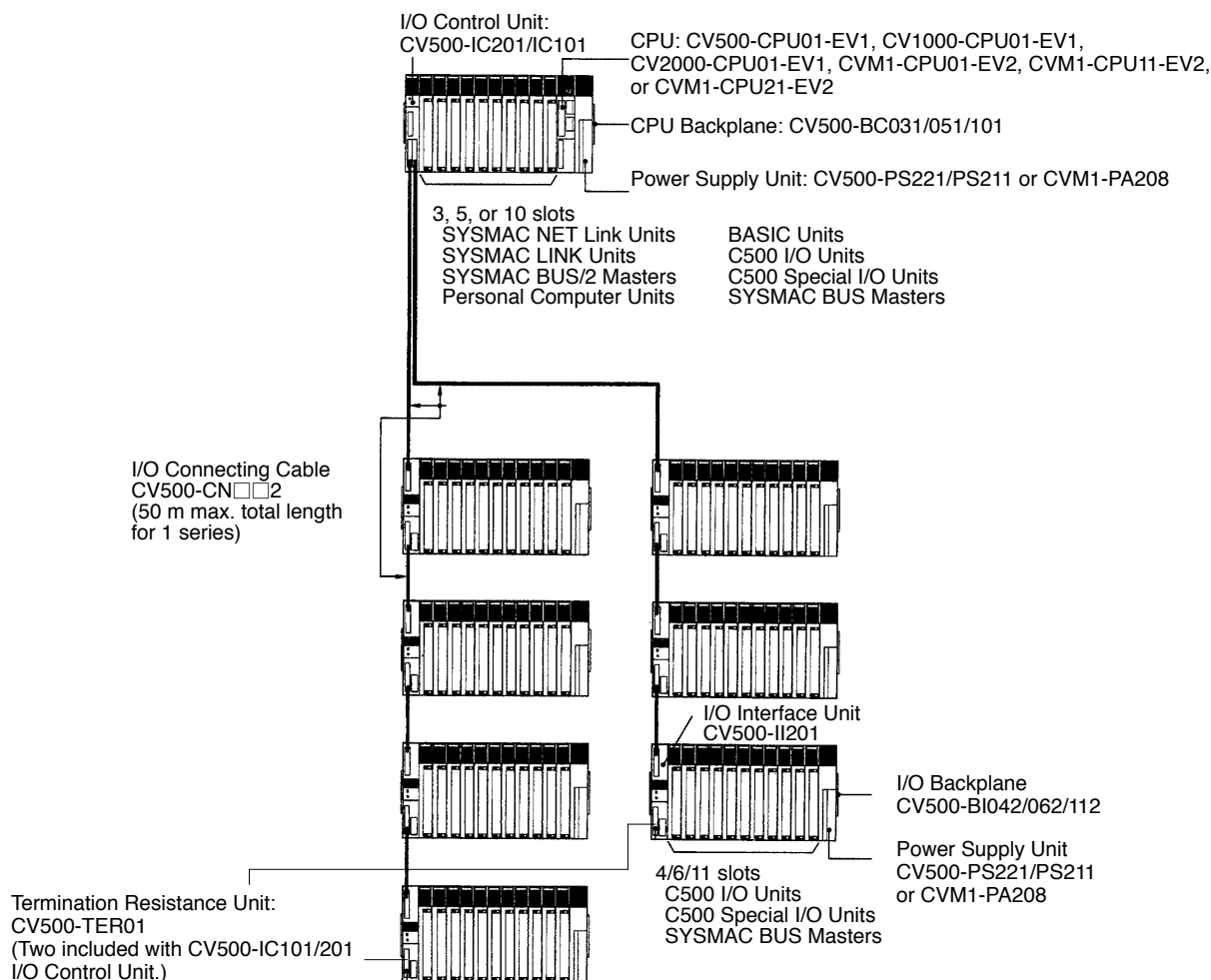

Systems with an Expansion CPU Rack

When nine or more CPU Bus Units (Temperature Controller Data Link Units, SYSMAC NET Link Units, SYSMAC LINK Units, SYSMAC BUS/2 Remote I/O Master Units, Ethernet Units, BASIC Units, and Personal Computer Units) are required in a System, the CPU Rack may be extended by connecting an Expansion CPU Rack to enable mounting up to 16 CPU Bus Units.

Only one Expansion CPU Rack may be connected to a CPU Rack. A system that includes an Expansion CPU Rack can be extended by connecting up to six Expansion I/O Racks. The Expansion I/O Racks may be connected in one or two series from the CPU Rack. The total length of I/O Connecting Cable must be 50 m or less for each series and a Termination Resistance Unit must be connected to the last Rack or to the unused I/O Control Unit connector.

Using an Expansion CPU Rack does not increase the maximum I/O capacity of the PC; it only increases the number of CPU Bus Units that can be used.

Units can be mounted to any slot on the Racks shown for them below.

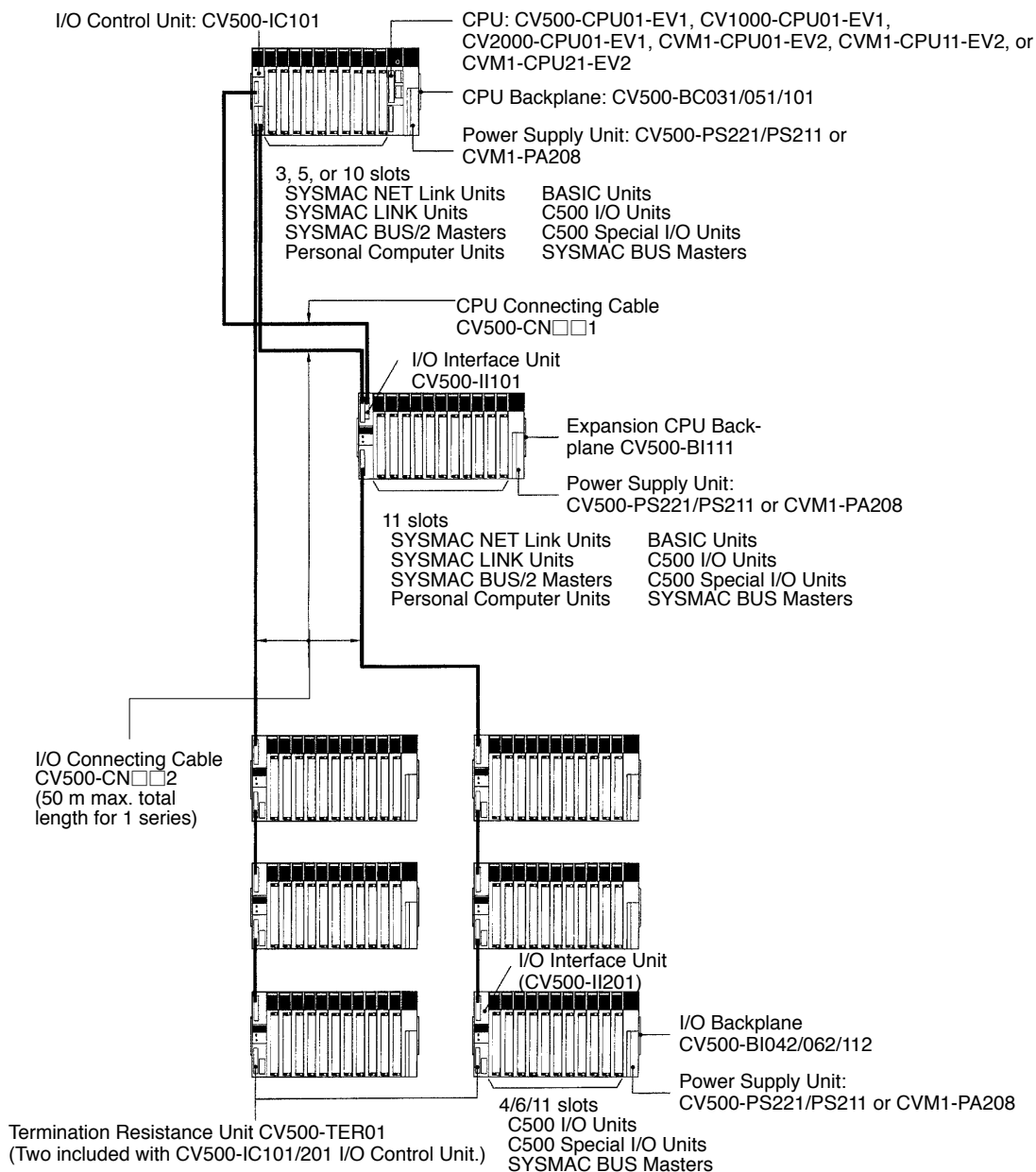

Systems with a Single Expansion I/O Rack

When only one Expansion I/O Rack is required, a simplified system configuration may be used. The CPU Backplane can be connected directly to the Expansion I/O Backplane without the use of the I/O Control and I/O Interface Units. Termination Resistance Units are also not required.

All Units except for CPU Bus Units (Temperature Controller Data Link Units, SYSMAC NET Link Units, SYSMAC LINK Units, SYSMAC BUS/2 Masters, Ethernet Units, Personal Computer Units, and BASIC Units) can be mounted to any of the Backplanes for which they listed in the following diagram. CPU Bus Units can be mounted to any slot on any CPU Backplane except for the CVM1-BC053 or CVM1-BC103 Backplane, on which CPU Bus Units can be mounted only to the rightmost 3 and 6 slots, respectively.

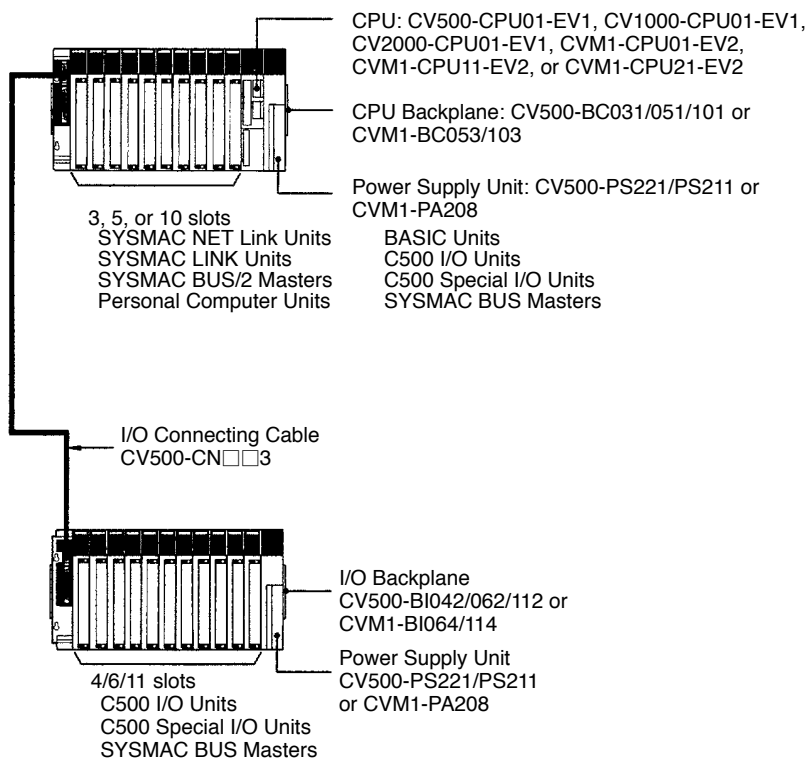

Systems with C500 Expansion I/O Racks

The following figure shows an assembled CV-series CPU Rack and seven C500 Expansion I/O Racks. Up to seven C500 Expansion I/O Racks may be connected to the CPU Rack. The total length of the I/O Connecting Cable must be 5 m or less and each section of I/O Connecting Cable must be 2 m or less. Termination Resistance Units are not necessary.

Expansion I/O Racks for the CV-series cannot be used together with C500 Expansion I/O Racks.

Units can be mounted to any slot on the Racks shown for them below.

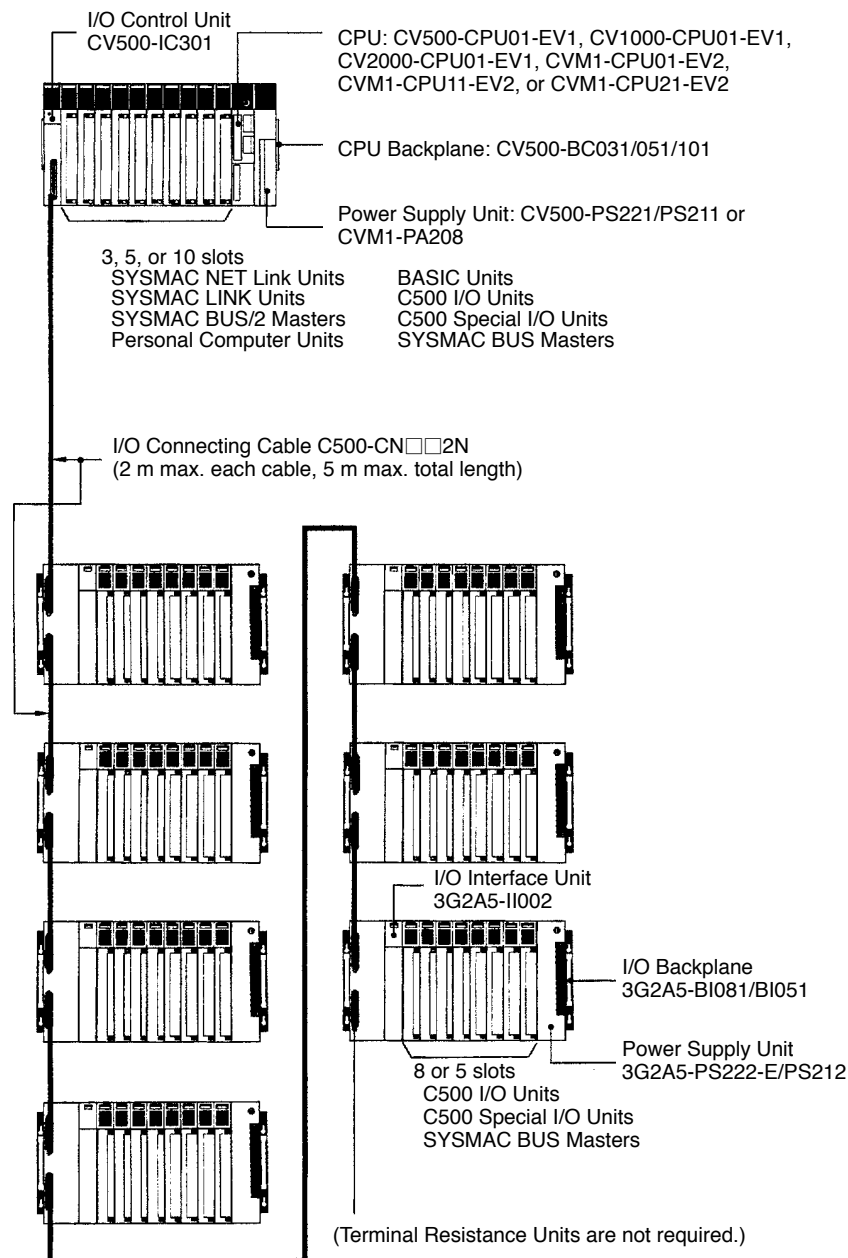

Rack Configurations

The following table summarizes the components required to form each type of Rack in the different configurations. The number of each component required for the System is given in parentheses. The following combinations form the basic Racks to which the other Units indicated in the first part of this section can be added.

Configuration	CPU Rack		Connecting cable	Expansion Rack		
	CPU Backplane	I/O Control Unit		I/O Interface Unit	Expansion Backplane	Termination Resistance Unit
CPU Rack only	CV500-BC031, CV500-BC051, CV500-BC101, CVM1-BC053, or CVM1-BC103 (one)	Not needed	Not needed	Not needed	Not needed	Not needed
CPU Rack and Expansion CPU Rack only	CV500-BC031, CV500-BC051, or CV500-BC101 (one)	CV500-IC101 (one)	CV500-CN□□1 (one) CV500-CN□□2 (one)	CV500-II101 (one)	CV500-BI111 (one)	CV500-TER01 (Two included with I/O Control Unit.) (two)
CPU Rack, Expansion CPU Rack, and Expansion I/O Racks	CV500-BC031, CV500-BC051, or CV500-BC101 (one)	CV500-IC101 (one)	CV500-CN□□1 (one) CV500-CN□□2 (one)	CV500-II101 (one)	CV500-BI111 (one)	CV500-TER01 (Two included with I/O Control Unit.) (two)
			CV500-CN□□2 (one for each Expansion I/O Rack)	CV500-II201 (one for each Expansion I/O Rack)	CV500-BI042, CV500-BI062, or CV500-BI112 (one for each Expansion I/O Rack)	
CPU Rack and Expansion I/O Racks	CV500-BC031, CV500-BC051, or CV500-BC101 (one)	CV500-IC201 or CV500-IC101 (one)	CV500-CN□□2 (one for each Expansion I/O Rack)	CV500-II201 (one for each Expansion I/O Rack)	CV500-BI042, CV500-BI062, or CV500-BI112 (one for each Expansion I/O Rack)	
CPU Rack with Single Expansion I/O Rack	CV500-BC031, CV500-BC051, CV500-BC101, CVM1-BC053, or CVM1-BC103 (one)	Not needed	CV500-CN□□3 (one)	Not needed	CV500-BI042, CV500-BI062, CV500-BI112, CVM1-BI064, or CVM1-BI114 (one)	Not needed
CPU Rack with C500 Expansion I/O Racks	CV500-BC031, CV500-BC051, or CV500-BC101 (one)	CV500-IC301 (one)	C500-CN□□2N (one for each Expansion I/O Rack)	C500-II002 (one for each Expansion I/O Rack)	C500-BI081 or C500-BI051 (one for each Expansion I/O Rack)	Not needed

Mounting Locations

The following table below summarizes the Units that can be mounted to CPU, Expansion CPU, Expansion I/O, and Slave Racks. For detailed information about the Units listed below, refer to the operation manual for the individual Unit.

Unit	CPU Rack	Expansion CPU Rack	Expansion I/O Racks	Slave Racks (CV- or C-series)	Remarks
16-/32-/64-point I/O Units	Yes	Yes	Yes	Yes	---
Service Power Supplies	Yes	Yes	Yes	Yes	---
Interrupt Input Units	Yes	Yes	No	No	Up to 4 Units can be mounted. When mounting to the Expansion CPU Rack, set the rack number to 1.
C500 Special I/O Units	Yes	Yes	Yes	Yes The following cannot be mounted to SYSMAC BUS/2 Slave Racks: NC103, NC221, NC222, CP131, FZ001, PID01, and MCC01. The following cannot be mounted to SYSMAC BUS Slave Racks: NC221, NC222, CT041, and FZ001. All other Special I/O Units can be mounted.	Up to 8 of the following Units can be mounted: Analog Input, Analog Output, High-speed Counter, PID, Position Control, Magnetic Card, ASCII, ID Sensor, and Ladder Program I/O. Position Control Units, NC103-E, and PID Units use 2 slots. READ(190)/WRIT(191) cannot be used with Units mounted to SYSMAC BUS Slave Racks.
BASIC Units	Yes	Yes	No	No	Up to 16 CPU Bus Units can be used with each PC, including 2 Remote I/O Master Units for the CV500 or CVM1-CPU01-EV2 or 4 for the CV1000, CV2000, CVM1-CPU11-EV2, or CVM1-CPU21-EV2, up to a 4 each of the SYSMAC NET Link, SYSMAC LINK Units, Host Link Unit, or Ethernet Unit, and 1 CompoBus/D Master Unit. A Personal Computer Unit requires 4 slots.
Temperature Controller Data Link Unit	Yes	Yes	No	No	
Personal Computer Units	Yes	Yes	No	No	
SYSMAC NET Link Units	Yes	Yes	No	No	
SYSMAC LINK Units	Yes	Yes	No	No	
SYSMAC BUS/2 Remote I/O Master Units	Yes	Yes	No	No	
Ethernet Units	Yes	Yes	No	No	
CompoBus/D Master Unit	Yes	Yes	No	No	
SYSMAC BUS Remote I/O Master Units	Yes	Yes	Yes	No	Up to 4 Units can be mounted to a CV500 or CVM1-CPU01-EV2 and eight Units to a CV1000, CV2000, CVM1-CPU11-EV2, or CVM1-CPU21-EV2.
SYSMAC BUS I/O Link Units	Yes	Yes	Yes	No	I/O cannot be set to 16 input/16 output.

Configuration Limits

The following two tables indicate limits on the system configuration. The first table indicates limits for the basic System. The second table indicates limits for Remote I/O Systems.

Basic System

Item	CV500 or CVM1-CPU01-EV2	CV1000 or CVM1-CPU11-EV2	CV2000 or CVM1-CPU21-EV2
Number of I/O points	512 points (32 words)	1,024 points (64 words)	2,048 points (128 words)
Number of connectable Expansion CPU Racks	1		
Number of connectable Expansion I/O Racks	7 (6 if an Expansion CPU Rack is also used)		
Number of I/O slots on CPU Rack	3/5/10		
Number of I/O slots on Expansion CPU Rack	11		
Number of I/O slots on Expansion I/O Rack	4/6/11		

Remote I/O Systems

Item		SYSMAC BUS/2 (see note 2)		SYSMAC BUS		
		CV500 or CVM1-CPU01 -EV2	CV1000, CV2000, CVM1-CPU11 -EV2, or CVM1-CPU21 -EV2	CV500 or CVM1-CPU01 -EV2	CV1000, CV2000, or CVM1-CPU11 -EV2	CVM1-CPU21 -EV2
Limits per PC	No. of remote I/O points	1,024 pts (64 words)	2,048 pts (128 words)	512 pts (32 words)	1,024 pts (64 words)	2,048 pts (128 words)
	No. of Remote Masters	2	4	4	8	
	No. of Slave Racks	---	---	8	16	
Limits per Remote I/O Master Unit	No. of Slaves (see note 1)	58M Slaves: 8 Units		2	8	
		122M Slaves: 4 Units				
		54MH Slaves: 4 Units				
	No. of remote I/O points	58M Slaves: 464 input and 464 output		512 pts (32 words)		
122M Slaves: 976 input and 976 output						
54MH Slaves: 432 input and 432 output						
Combined No. of Slaves, I/O Link Units, Optical I/O Units, and I/O Terminals		---		64 (optical) 32 (wired)		
Expansion I/O Backplanes		CV500-BI112/062/042		C500-BI081/051		

- Note**
1. 58M Slaves are counted as one Unit and 122M and 54 MH Slaves are counted as two Units in figuring the total of eight connectable Units. 58M, 122M, and 54MH classifications are set with a switch on the Slave.
 2. A SYSMAC BUS/2 Slave must be designated "54MH" to use READ(190)/WRIT(191) for Special I/O Units mounted to it. These instructions cannot be used for SYSMAC BUS Slaves regardless.

2-2 Racks

This section describes the Racks used to construct a PC System. The individual components used to construct the Racks are described in the next section.

2-2-1 CPU Racks

The following figure shows the parts of the CPU Rack. There are five Backplanes available for the CPU Rack. Any CPU can be mounted to any Backplane. The only differences in the Backplanes is the number of slots that they provide for Units, their expansion capability, and the number of slots for CPU Bus Units. The CV500-BC031, CV500-BC051, and CV500-BC101 provide complete expansion capability and provide 3, 5, and 10 slots, respectively, for Units other than the CPU, Power Supply Unit, and I/O Control Unit.

The CVM1-BC053 and CVM1-BC103 do not support I/O Control Units and provide 5 and 10 slots, respectively, for Units other than the CPU and Power Supply Unit. Because I/O Control Units are not supported, these Backplanes can be connected only to a single Expansion I/O Rack as illustrated on page 18. The CPU Backplane cannot be used for an Expansion CPU or Expansion I/O Rack.

CPU Backplane	No. of slots	CPU Bus Unit slots	I/O Control Unit
CV500-BC031	3	3	Yes
CV500-BC051	5	5	Yes
CV500-BC101	10	10	Yes
CVM1-BC053	5	Rightmost 3	No
CVM1-BC103	10	Rightmost 6	No

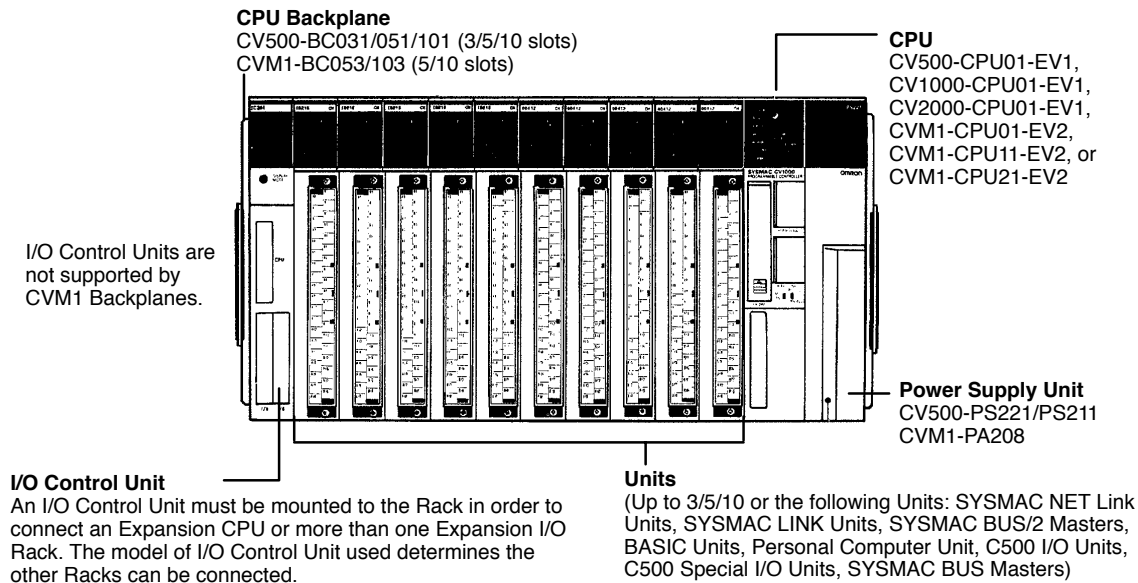

Note The Units in the following table can be mounted to the CV500-BC101 CPU Backplane if a CV500-IC□□□ I/O Control Unit and CV500-II□□□ I/O Interface Unit are used. If an I/O Control Unit is not used, only one Expansion I/O Rack can be connected and a total of eight Units maximum can be mounted to the PC regardless of the Rack to which they are mounted.

Name	Model
Analog Input Unit	3G2A5-AD□□□, C500-AD101
High-speed Counter Unit	3G2A5-CT□□□, C500-CT041
Analog Output Unit	3G2A5-DA□□□, C500-DA101
Fuzzy Logic Unit	C500-FZ001
ID Sensor Unit	C500-IDS□□□/IDS01-V1
Ladder Program I/O Unit	C500-LDP01-V1
Position Control Unit	3G2A5-NC103-E/-NC111-EV1, C500-NC222-E
SYSMAC BUS Optical Remote I/O Master Unit	3G2A5-RM001-PEV1/-RM001-EV1, C500-RM201
ASCII Unit	C500-ASC04
Cam Positioner Unit	C500-CP131
Magnetic Card Reader Unit	3G2A5-MGC01
PID Control Unit	3G2A5-PID01-E

2-2-2 Expansion CPU Racks

An Expansion CPU Rack can be provided to increase the mounting space for CPU Bus Units. The Expansion CPU Rack is connected directly to the CPU Rack. Two cables are required to connect the Expansion CPU Rack to the CPU Rack, a CPU Bus Cable and an I/O Connecting Cable. If either of these connections is broken, the system will be disabled.

Only one Expansion CPU Rack can be connected to the CPU Rack. To further increase the number of I/O Units, a series of Expansion I/O Racks may be connected to the Expansion CPU Rack or to the I/O Control Unit on the CPU Rack. If no Expansion I/O Rack is connected to the I/O Interface Unit, connect a Termination Resistance Unit to the unused connector on the I/O Interface Unit.

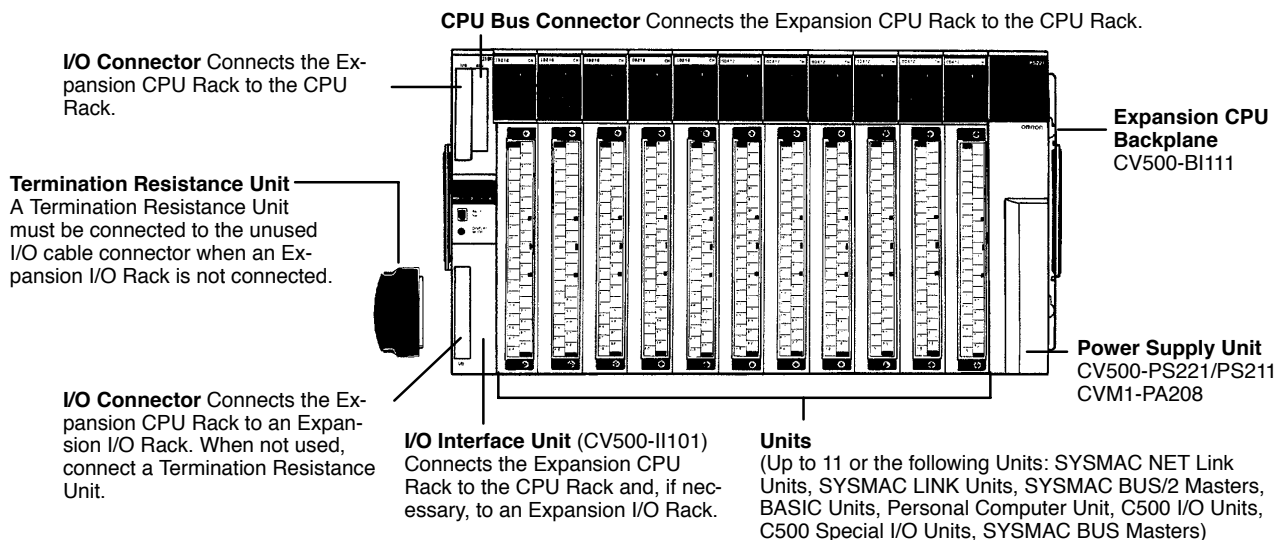

2-2-3 Expansion I/O Racks

Expansion I/O Racks, shown in the following diagram, can be used to expand the CV-series PCs. There are five models of Expansion I/O Backplane that can be used, as shown in the following table. These vary in the number of slots that they provide for Units (other than the Power Supply Unit and I/O Interface Unit) and in expansion capabilities. CV500 Expansion I/O Backplanes offer complete expansion capabilities, while CVM1 Expansion I/O Backplanes do not support I/O Interface Units and thus must be connected directly to the CPU Backplane (see *Single Expansion I/O Rack* in this subsection).

Expansion I/O Backplane	No. of slots	I/O Interface Unit
CV500-BI042	4	Yes
CV500-BI062	6	Yes
CV500-BI112	11	Yes
CVM1-BI064	6	No
CVM1-BI114	11	No

An Expansion I/O Rack can be connected either directly to the CPU Backplane (see *Single Expansion I/O Rack* in this subsection) or to an I/O Control Unit. Up to seven Expansion I/O Racks can be connected to the I/O Control Unit on the CPU Rack in two series unless an Expansion CPU Rack is connected, in which case only six Expansion I/O Racks may be connected. If an Expansion CPU Rack is connected, one of the series of Expansion I/O Racks is connected to the I/O Control Unit on the CPU Rack and the other one is connected to the I/O Interface Unit on the Expansion CPU Rack.

Attach a Termination Resistance Unit to the unused terminal on the I/O Interface Unit of the last Expansion I/O Rack in each series. If two series of Expansion I/O Racks are used, connect a Termination Resistance Unit to the last Rack in each.

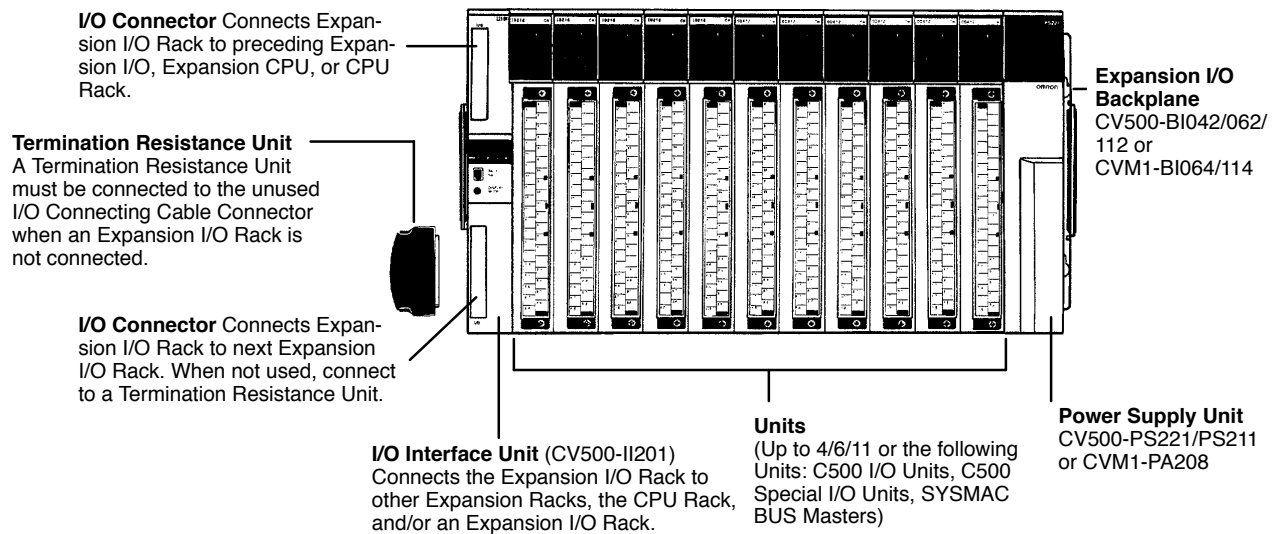

Single Expansion I/O Rack

If only one Expansion I/O Rack is required and no Expansion CPU Rack is used, a single Expansion I/O Rack can be connected directly to the CPU Rack without an I/O Control Unit or I/O Interface Unit. The Racks are connected directly via the connectors on the two Backplanes. Termination Resistance Units are also not required. In every other respect, the Expansion I/O Rack is identical to Expansion I/O Racks in connected via I/O Control and I/O Interface Units.

SYSMAC BUS/2 Slave Racks

The SYSMAC BUS/2 Slave Racks use the same Expansion I/O Backplane and Power Supply Unit as the Expansion I/O Racks, but a Remote I/O Slave Unit is mounted instead of the I/O Interface Unit and the Slave Rack is connected from the Remote I/O Slave Unit to a Remote I/O Master Unit on the CPU or Expansion CPU Rack. Refer to the *SYSMAC BUS/2 Remote I/O System Manual* for details.

2-3 Rack Components

This section describes the main components that are used to construct CPU, Expansion CPU, and Expansion I/O Racks.

2-3-1 CPUs

Six CPU models are available, the CV500-CPU01-EV1, CV1000-CPU01-EV1, CV2000-CPU01-EV1, CVM1-CPU01-EV2, CVM1-CPU11-EV2, and CVM1-CPU21-EV2. The following figure shows the CV1000-CPU01-EV1.

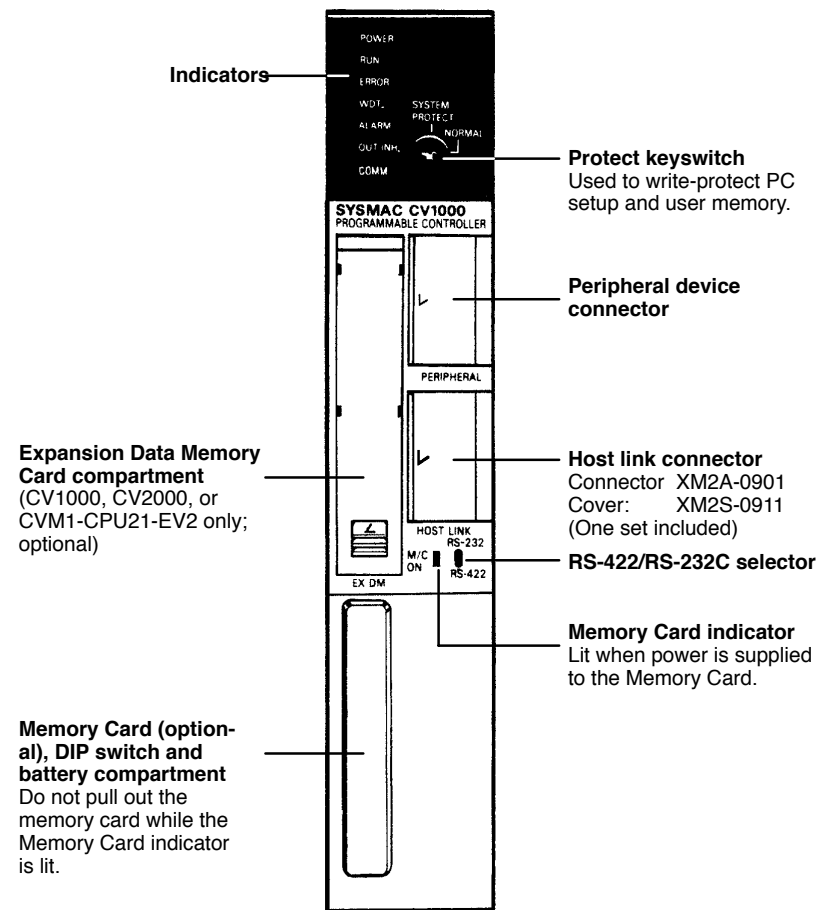

Note The Memory Unit is built into CVM1/CV-series PCs; it is not necessary for the user to install one, as is necessary for some C-series PCs.

Protect Keyswitch

The protect keyswitch write-protects the current PC Setup and user program memory. The user program memory can also be write-protected by the using the "Protect UM" function from the CVSS. When set to "SYSTEM PROTECT" this switch will write-protect the entire user program memory even if only part of it is protected using the "Protect UM" function from the CVSS.

CPU Indicators

The following table describes the indicators on the front panel of the CPU.

Indicator	Operation
POWER (green)	Lights when power is supplied to the CPU.
RUN (green)	Lights when the PC is operating normally.
ERROR (red)	Lights when an error in the CPU causes operation to stop. When the ERROR indicator lights, the RUN indicator will go out and all outputs from Output Units will be turned OFF.
WDT (red)	Lights when a CPU error (watchdog timer error) has been detected. When the WDT indicator lights, the RUN indicator will go out and all outputs from Output Units will be turned OFF.
ALARM (red)	Lights when non-fatal error is detected.
OUTINH (orange)	Lights when the Output OFF Bit (A00015) is turned ON to turn OFF PC outputs.
COMM (orange)	Lit from when data is received from the host computer until the response is completed.

DIP Switch Settings

The DIP switch is used to set certain basic operational parameters for the CPU. To gain access to the DIP switches, open the cover of the Memory Card compartment as shown in the following figure. Turn off power to the PC before setting the DIP switch.

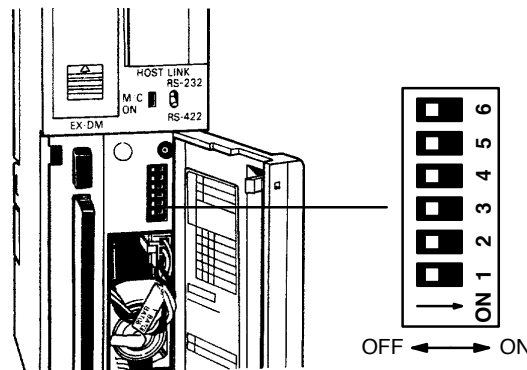

Pin	Function
6	Specifies whether the termination resistance is connected for the Host Link System. Turn this pin ON to connect the terminal resistance. When RS-422 is used set this pin to ON at the last PC connected in the Host Link System. When RS-232C is used, this pin does not affect Host Link System operation and may be set to either ON or OFF.
5	To transfer the user program file (AUTOEXEC.OBJ) and the PC Setup (AUTOEXEC.STD) from the Memory Card to the CPU on power application, set this pin to ON. If this pin is set to OFF, the PC Setup can be changed from the CVSS so that only the user program (AUTOEXEC.OBJ) is transferred when power is turned on. If program transfer is designated both with this pin setting and in the PC Setup, then both the program file and the PC Setup will be transferred. The user program will not be transferred when the system protect keyswitch on the front panel of the CPU is set to the SYSTEM PROTECT position, or memory is write-protected from the CVSS.
4	Set this pin to the ON position to establish the following communications settings for the host link interface. These are the most common setting for an IBM PC/AT interface. Baud rate: 9,600 bps Unit number: 0 Parity: Even Data length: 7 bits Stop bits: 2 When this pin is OFF, the communications settings for the host link interface are set in the PC Setup. Refer to the <i>CVSS Operation Manuals</i> for details on the PC Setup. Note: The above settings apply to CPUs manufactured from July 1995 (lot number **75 for July 1995). For CPUs manufactured before July 1995 (lot number **65 for June 1995), only 1 stop bit will be set and the baud rate will be 2,400 bps.

Pin	Function															
3	Set this pin to ON when using the host link interface with a PT using NT Link communications. Set this pin to OFF when using the host link interface for host link communications.															
1 and 2	These pins set the baud rate of the peripheral device connector. Set the rate to 50,000 bps when connecting the interface to the GPC or Programming Console. Set the rate to 9,600 bps when connecting to a personal computer running CVSS. <table border="1" data-bbox="326 268 659 422"> <thead> <tr> <th>Pin 1</th> <th>Pin 2</th> <th>Baud rate</th> </tr> </thead> <tbody> <tr> <td>0</td> <td>0</td> <td>50,000 bps</td> </tr> <tr> <td>1</td> <td>0</td> <td>19,200 bps</td> </tr> <tr> <td>0</td> <td>1</td> <td>9,600 bps</td> </tr> <tr> <td>1</td> <td>1</td> <td>4,800 bps</td> </tr> </tbody> </table>	Pin 1	Pin 2	Baud rate	0	0	50,000 bps	1	0	19,200 bps	0	1	9,600 bps	1	1	4,800 bps
Pin 1	Pin 2	Baud rate														
0	0	50,000 bps														
1	0	19,200 bps														
0	1	9,600 bps														
1	1	4,800 bps														

Memory Cards

Memory Cards can be used to store data or programs as files to expand the memory storing capacity of the PC. Memory Cards fit into the slot located on the lower left side of the CPU. Memory Cards are not provided with the PC and must be ordered separately and installed in the CPU. There are three types of Memory Cards that can be used for the CV-series PCs: RAM, EEPROM, or EPROM.

Memory type	Model	Capacity	Remarks
RAM	HMC-ES641	64K bytes	---
	HMC-ES151	128K bytes	
	HMC-ES251	256K bytes	
	HMC-ES551	512K bytes	
EEPROM	HMC-EE641	64K bytes	CV500-MCW□□ Memory Card Writer or Peripheral Device required
	HMC-EE151	128K bytes	
EPROM	HMC-EP551	512K bytes	CV500-MCW□□ Memory Card Writer or Peripheral Device required
	HMC-EP161	1M bytes	

For CPU Units with a lot number that contains the last-digit suffix of "6" (□□□6) or higher, the following products are available on the market and can be used as Memory Cards provided that they be used in the same manner as for the conventional Memory Cards.

- A 64K-byte, 128K-byte, 256K-byte, 512K-byte, 1M-byte, or 2M-byte RAM that conforms to JEIDA4.0. The 2M-byte RAM is not applicable to the CV500-MCW01 Memory Card Writer.

RAM and EEPROM Cards

Data can be randomly written to and read from RAM or EEPROM Cards, making it possible to easily stored programs. The memory of a RAM Cards is erased, however, when power is not supplied to the CPU or when the RAM Card is removed from the CPU without first being connected to a backup battery. EEPROM Cards cannot be written while mounted in the CPU. Data can be written to RAM Cards while they are mounted in the CPU by using the CVSS or by instructions in the user program.

Both the RAM and EEPROM Memory Cards are equipped with write-protect switches. Setting the write-protect switch to ON prevents data from being written to or erased from the Card. Setting the write-protect switch to OFF allows data to be written to or erased from the Card.

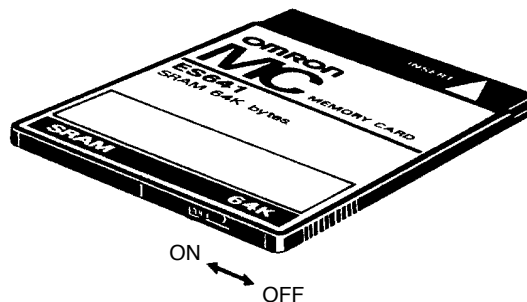

Four RAM Memory Card models are available, varying in memory capacity from 8K, 16K, 32K to 64K words. Two EEPROM Memory Card models are available, one containing 8K words of memory and the other 16K words of memory.

RAM Card Backup Battery

Insert a battery into a RAM Memory Card before mounting the Card into the CPU. Leave the battery in its holder. Battery life expectancies are given below. Replace the battery within the time listed. Refer to *Section 4 Inspection and Maintenance* for the battery replacement procedure.

Card	Capacity	Life
HMC-ES641	64K bytes	5 years
HMC-ES151	128K bytes	2 years
HMC-ES251	256K bytes	1 year
HMC-ES551	512K bytes	6 months

EPROM Cards

Data contained in the ROM Card is stored on EPROM chips and cannot be altered or erased during the CPU's operation. The EPROM chip is mounted to the Memory Card and the entire pack is installed in the CPU. Once data is written to the chip, the data will not be lost when the power to the PC is OFF.

ROM Cards are shipped unprogrammed. The ROM Card can be programmed using a CV500-MCW□□ Memory Card Writer.

The procedure for erasing EPROM Memory Card data is as follows:

- 1, 2, 3... 1. Open the memory card cover by pressing at an angle on the catch at the bottom edge of the card using a pointed object, such as a pen.
2. Erase the data from the EPROM chips by exposing the window of the EPROM chips to ultraviolet light. Any of a number of commercially available EPROM erasers may be used. To ensure complete erasure, the Memory Card should be subject to a minimum exposure as specified by the eraser manufacturer.
3. Close the cover and slide the catch back into place.

Expansion Data Memory

An Expansion Data Memory Unit may be used only in a CV1000-CPU01-EV1, CV2000-CPU01-EV1, or CVM1-CPU21-EV2 CPU. The Expansion Data Memory Unit fits into the slot located on the upper left side of the CPU. The Expansion Data Memory Unit is optional. There are three models of Memory Units available with different memory capacities. The addition of an Expansion Data Memory Unit increases the data memory capacity of the CV1000, CV2000, or CVM1-CPU21 from 24K words (D00000 to D24575) to up to 256K words. Refer to the *CV-series PC Operation Manual: Ladder Diagrams* for details on PC memory and addressing conventions.

Model	Memory capacity	Word assignment
CV1000-DM641	64K words	E00000 to E32765 x 2 banks
CV1000-DM151	128K words	E00000 to E32765 x 4 banks
CV1000-DM251	256K words	E00000 to E32765 x 8 banks

When mounted to the CPU, the Expansion Data Memory Unit is backed up by the battery mounted in the CPU. Provided the Unit has been mounted to the CPU for a duration of at least 1 minute, a charged capacitor built-in to the Memory Unit allows the Unit to be removed from the CPU for up to 10 minutes without memory loss.

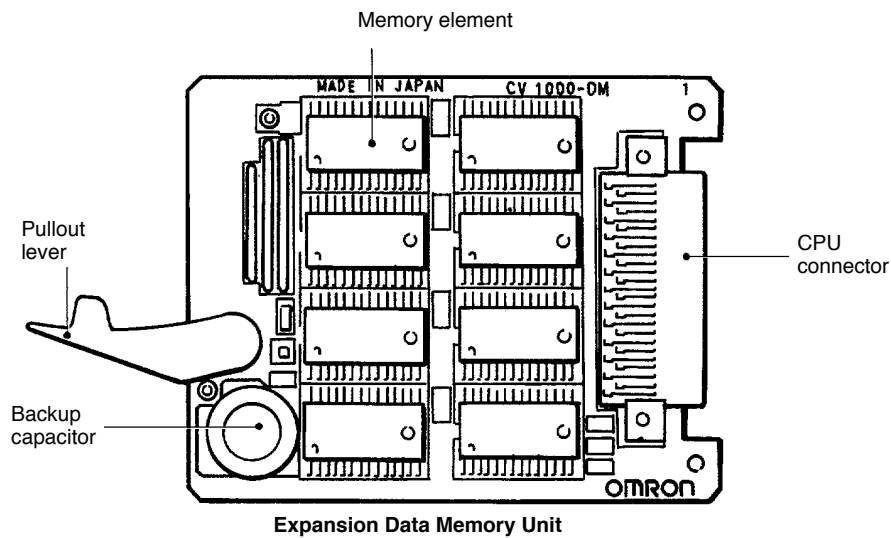

2-3-2 I/O Control Units

An I/O Control Unit must be mounted to the CPU Rack in order to connect the CPU Rack to an Expansion CPU Rack or to more than one Expansion I/O Rack. Three I/O Control Unit models are available, the CV500-IC101 for connecting an Expansion CPU Rack and/or CV-series Expansion I/O Racks, the CV500-IC201 for connecting just CV-series Expansion I/O Racks, and the CV500-IC301 for connecting C500 Expansion I/O Racks. An I/O Control Unit can be mounted even if no Expansion I/O or Expansion CPU Rack is used. The I/O Control Unit must be mounted to the leftmost slot on the CPU Backplane.

CV500-IC101

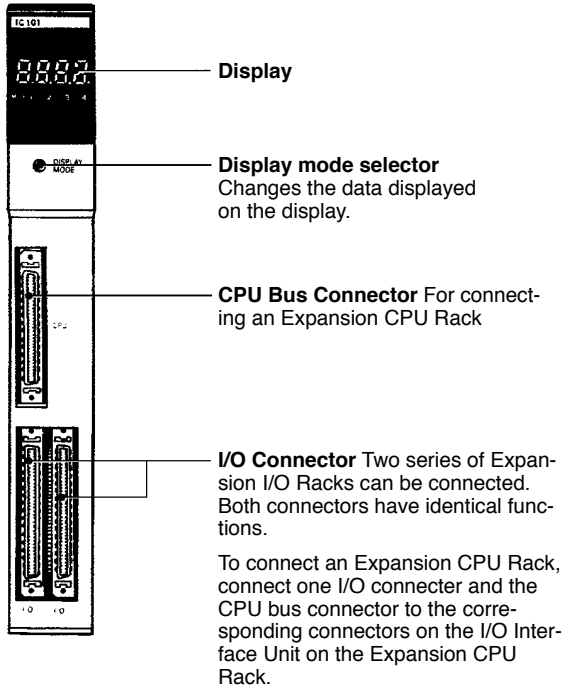

CV500-IC201

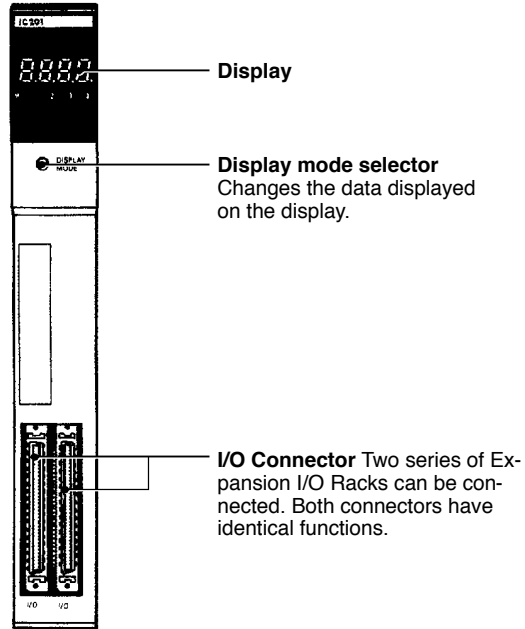

CV500-IC301

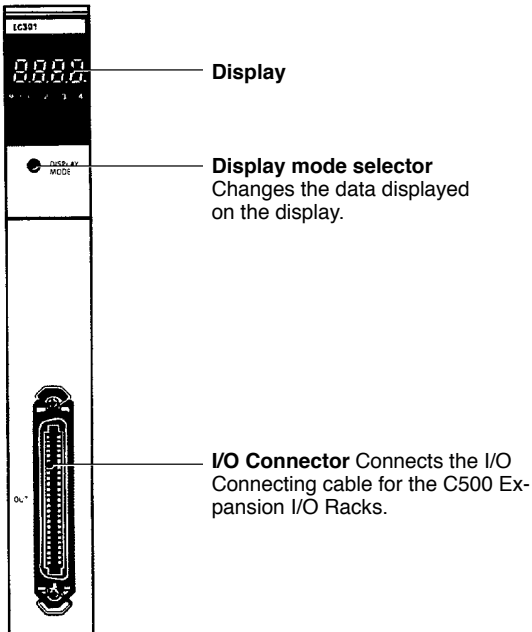

Display Modes

The display mode selector allows one of four modes to be selected. By pressing the switch successively, the four modes can be sequentially accessed. The current mode is displayed in the form of a dot on the display. The following diagram illustrates the four possible modes.

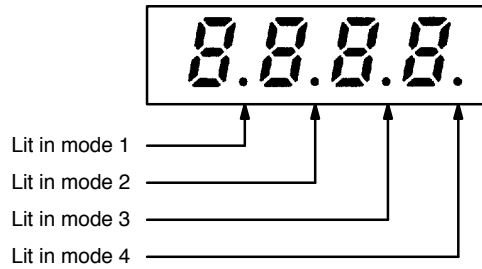

“0000” is displayed until the I/O Connecting Cables are connected properly.

Mode 1 displays the address of the first word on each Rack. The following example illustrates the mode 1 display for a given Rack.

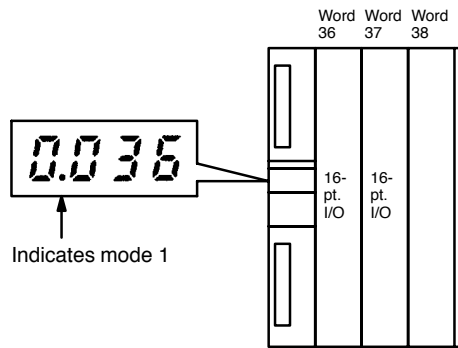

Mode 2 indicates the operating status of the CPU as well as the rack number.

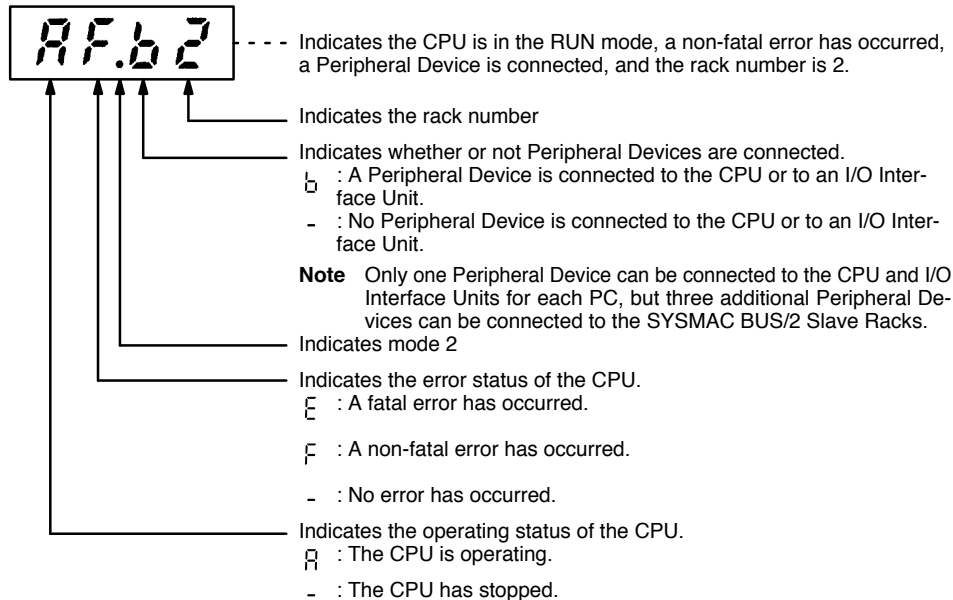

In **mode 3**, data can be output to the display by the I/O DISPLAY instruction (IODP(189)). The binary information can be display in hexadecimal format (0 to F) or as segments of a 7-segment display. For details on the I/O DISPLAY instruction, refer to the *CV-series PC Operation Manual: Ladder Diagrams*.

Mode 4 displays only the mode number dot.

2-3-3 I/O Interface Units

One I/O Interface Unit is needed on the Expansion CPU Rack and on each Expansion I/O Rack. Two models of I/O Interface Unit are available, the CV500-II101 for the Expansion CPU Rack and the CV500-II201 for Expansion I/O Racks. An I/O Interface Unit enable data communication between Racks. The I/O Interface Unit must be mounted to the leftmost slot on the Expansion CPU and Expansion I/O Backplane.

CV500-II101

I/O connectors The connectors are functionally identical and either can be used to connect to the preceding or succeeding Rack.

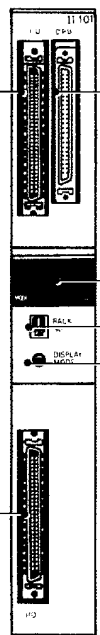

- CPU bus connector**
- Display**
- Rack number switch**
- Display mode switch** Changes the data displayed on the display.

CV500-II201

I/O Connectors Both connectors are functionally identical and either can be used to connect to the preceding or succeeding Rack.

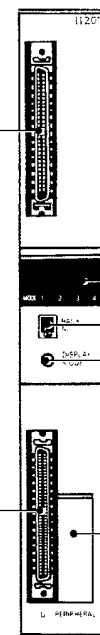

- Display**
- Rack number switch**
- Display mode switch** Changes the data displayed on the display.
- Peripheral device connector cover**

Attach a Termination Resistance Unit to the unused I/O Connecting Cable Connector of the last Rack in a each series leading from the CPU Rack.

Rack Number Switch

Each Expansion I/O and Expansion CPU Rack is assigned a rack number from 1 through 7. Set the rack number on the rack number switch. Words are allocated to Racks in order according to rack numbers, starting from the CPU Rack, which is always rack number 0.

Set the rack number switch using a standard screwdriver. If a number other than 1 through 7 is assigned, or the same rack number is set to more than one Rack, the PC will not operate

Note Turn OFF the power to the PC before setting the rack number switches.

Display

The display on the I/O Interface Unit is identical to that on the I/O Control Unit on the CPU Rack. For details on the data displayed in each mode, refer to 2-3-2 I/O Control Unit.

Peripheral Device Connector

The I/O Interface Unit CV500-II201 for Expansion I/O Racks provides a connector for connecting a Peripheral Device. One Peripheral Device (CVSS or Programming Console) can be connected per to the CPU or I/O Interface Units for each PC, although additional Peripheral Devices can be connected to Slave Racks if a SYSMAC BUS/2 System is used. Whether mounted to the CPU or an I/O Interface Unit, the operation of the Peripheral Device is the same.

Note When connecting a Peripheral Device to the CPU or an I/O Interface Unit, set the baud rate of the CPU to 50k bps via the CPU DIP switch.

2-3-4 Power Supply Units

The Power Supply Unit is available in three models. The CV500-PS221 and CVM1-PA208 run on 100 to 120 VAC or 200 to 240 VAC, and the CV500-PS211 runs on 24 VDC. Both Power Supply Units can be used with any CPU Rack, Expansion CPU Rack, Expansion I/O Rack, or Remote I/O Slave Rack. The table below summarizes the output capacity of the two models.

Model	Supply voltage	Output power
CVM1-PA208	100 to 120/200 to 240 VAC	8 A at 5 VDC
CV500-PS221		12 A at 5 VDC
CV500-PS211	24 VDC	12 A at 5 VDC

Note The total power consumed by each Rack must be within the values stated in the table above. For example, do not mount Units with a total current consumption greater than 12 A to a Rack supplied by a 12-A Power Supply Unit.

CV500-PS221/CVM1-PA208

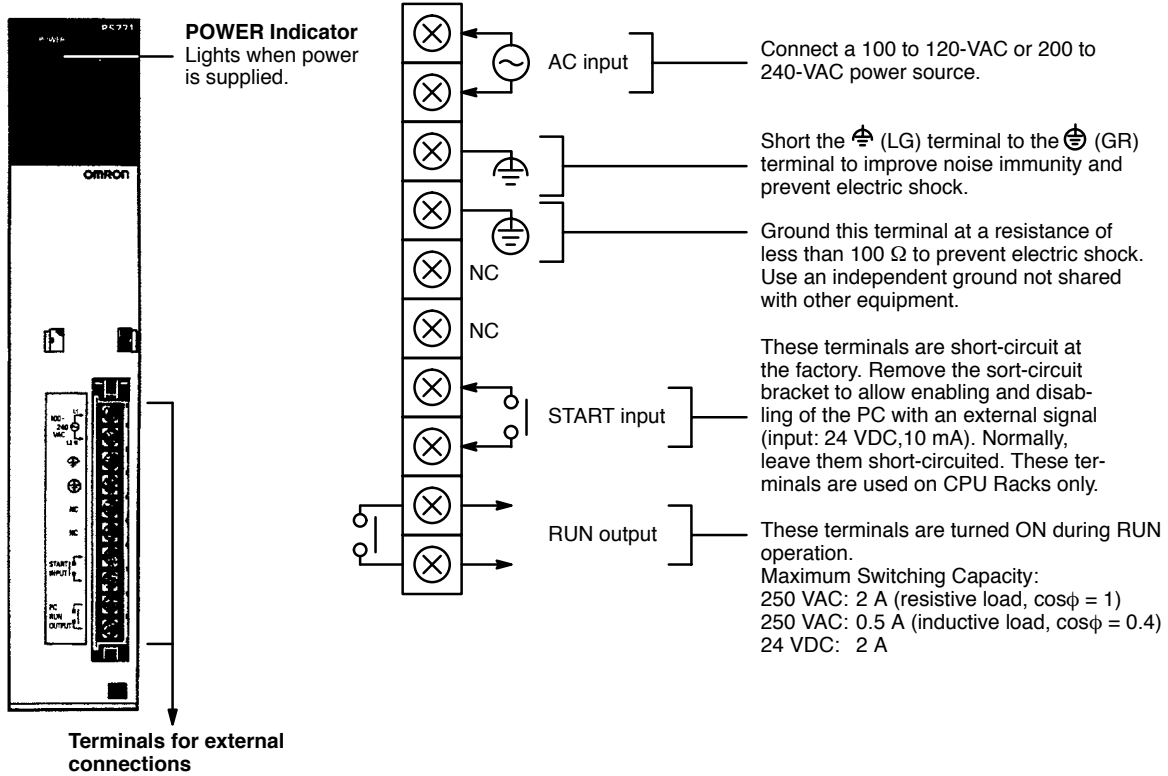

CV500-PS211

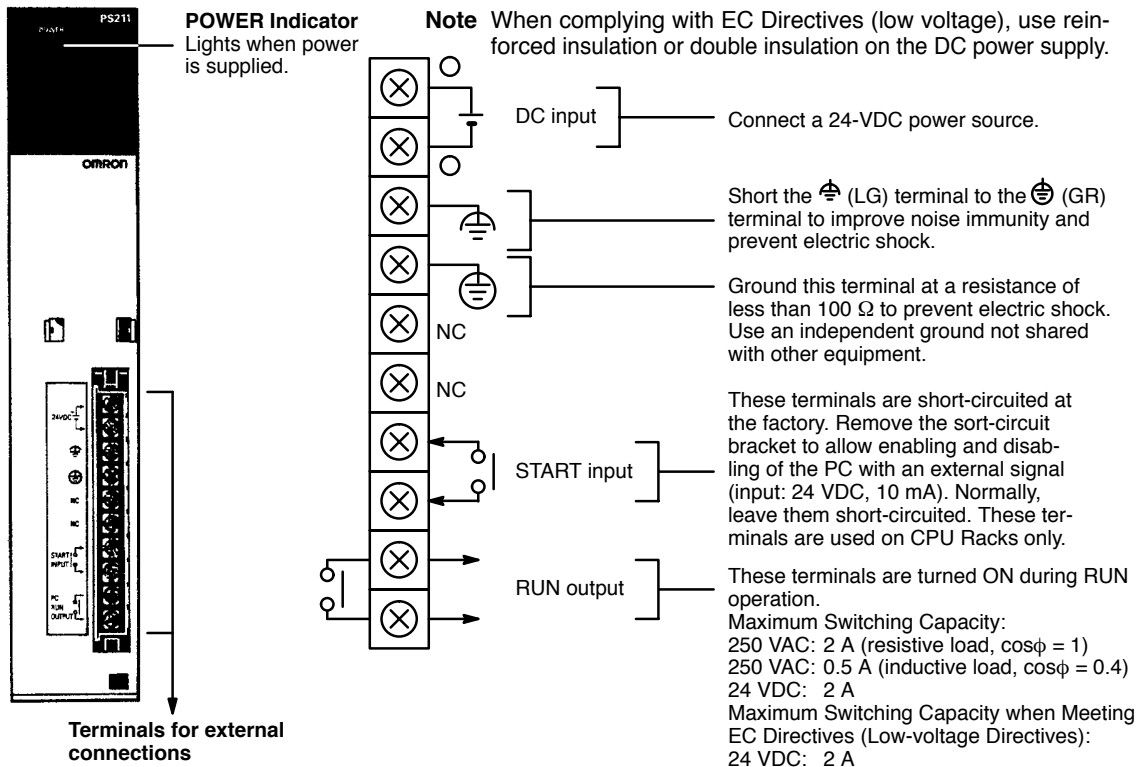

2-3-5 Termination Resistance Units

A Termination Resistance Unit (CV500-TER01) must be attached to all unused I/O connectors of I/O Control and I/O Interface Units in the system. Failure to attach Termination Resistance Units to the unused I/O connectors will result in an error and the incorrect operation of the PC. The following example illustrates the locations where Termination Resistance Units are required. Two Termination Resistance Units are provided with the CV500-IC101/201 I/O Control Unit.

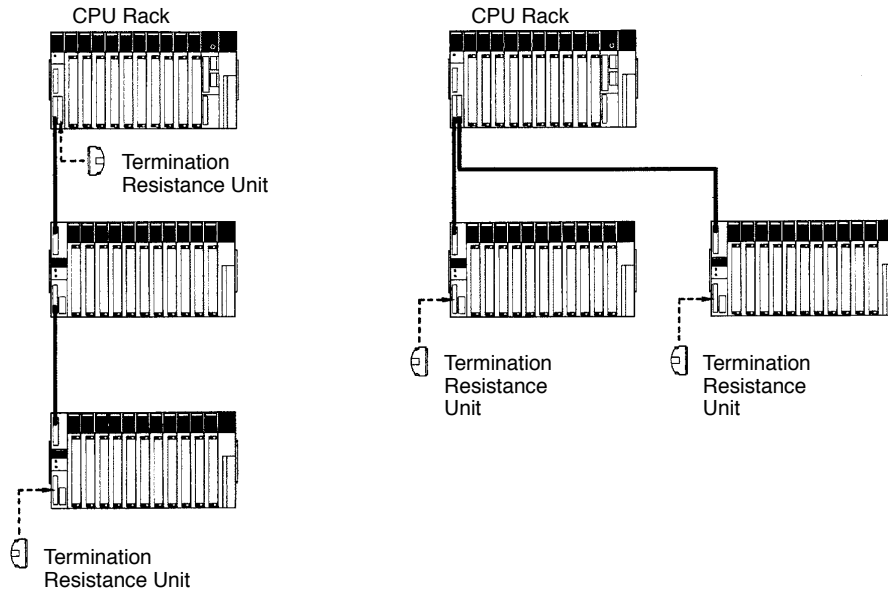

Note Attach and remove Termination Resistance Units only when PC power is OFF.

2-3-6 I/O Units

I/O Units come in 5 shapes; A-shape, B-shape, C-shape, D-shape, and E-shape. Refer to *Appendix B Specifications* for the dimensions of each I/O Unit.

A-shape

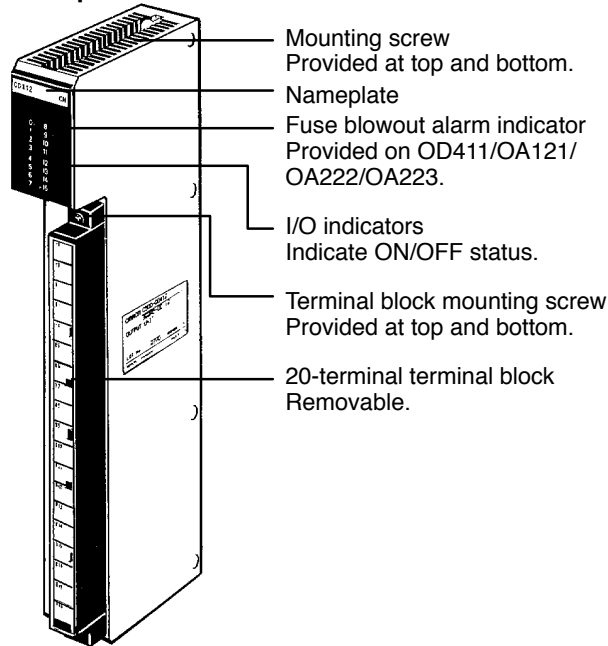

B-shape

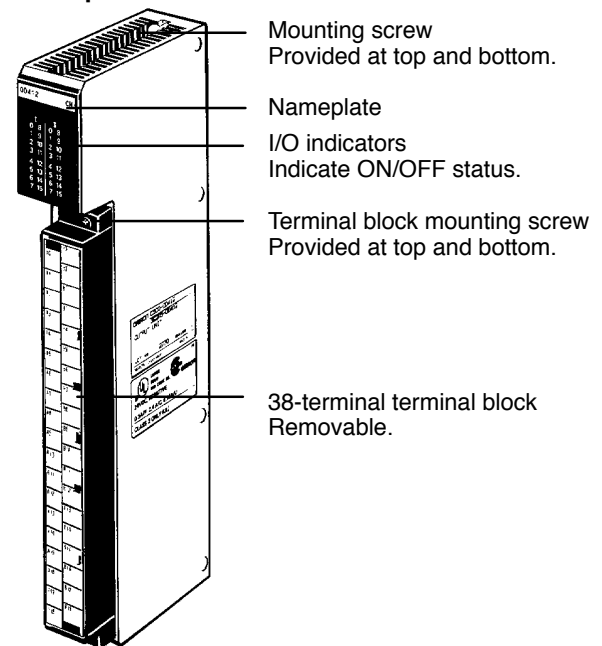

C-shape

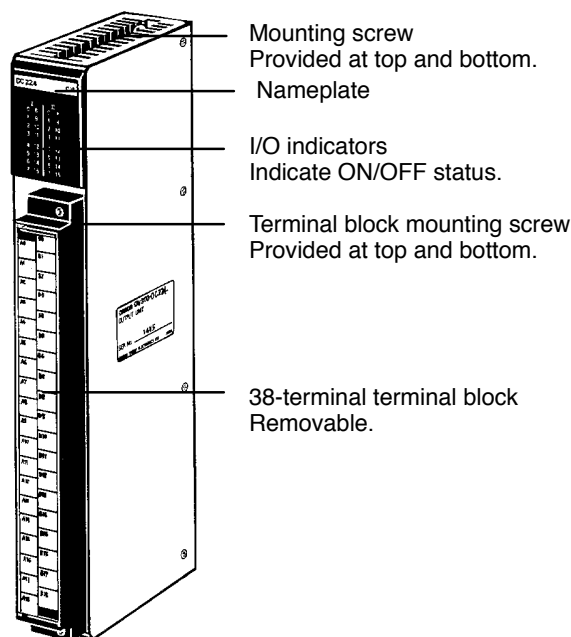

D-shape

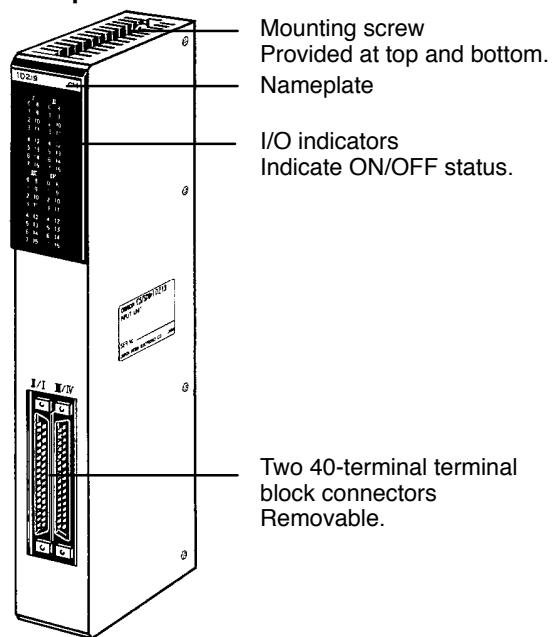

E-shape

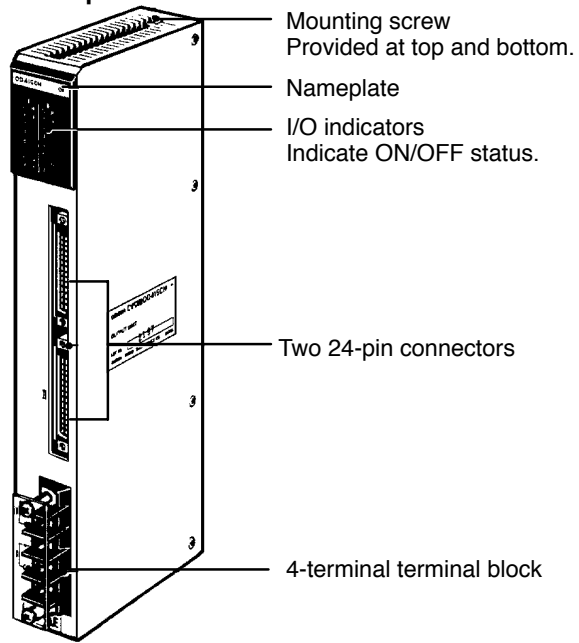

SECTION 3

Installation

This section describes how to assemble, mount, and wire a PC starting with a Backplane and use all the Units discussed in the previous section. Technical specifications and dimensions are provided in *Appendix B Specifications*.

- 3-1 Assembly
- 3-1-1 Mounting Units
- 3-1-2 Memory Card and Expansion Data Memory Unit
- 3-2 Installation Environment
- 3-3 Mounting Racks
- 3-3-1 Duct Work
- 3-4 Power Supply Units
- 3-4-1 Wiring the Power Source
- 3-4-2 Grounding
- 3-4-3 Wiring Other Terminals
- 3-4-4 Emergency Stop
- 3-4-5 Power Interruptions
- 3-4-6 Current Consumption
- 3-5 Wiring I/O Units
- 3-5-1 Terminal Blocks
- 3-5-2 Wiring Precautions
- 3-5-3 Wiring Examples
- 3-6 Compliance with EC Directives

3-1 Assembly

3-1-1 Mounting Units

To build a Rack PC, we start with a Backplane. The Backplane for a CV-series PC is illustrated below.



The Backplane has two functions: it provides physical support for the Units that are mounted to it and it provides the connectors and electrical pathways necessary for connecting the Units.

The first device we will mount to the Backplane is a Power Supply Unit. The Power Supply Unit fits into the rightmost slot on the Backplane and provides electricity at the voltage required by the other Units in the PC. It can also be used to power devices other than the PC if necessary and it enough current is available.

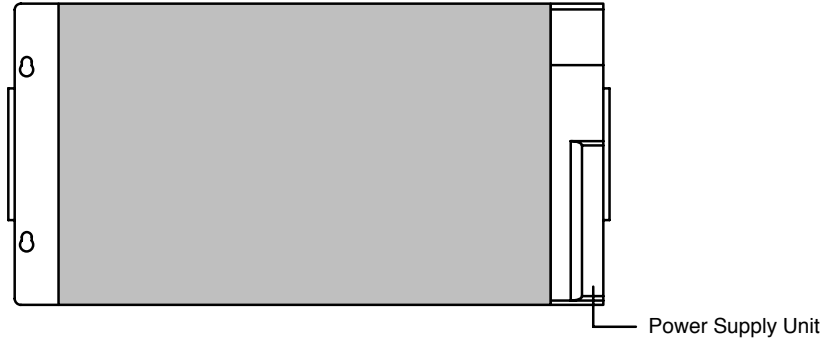

The CPU is mounted next to the Power Supply Unit. The CPU fits into the position directly to the left of the Power Supply Unit.



The CV-series CPUs have no I/O points built in. In order to complete the PC we need to mount one or more Units providing I/O points to the Backplane. Mount the Units to the Backplane by pressing them firmly into position, making sure the connectors are properly mated. Secure the Unit by tightening the mounting screws located on the top and bottom of the Unit.

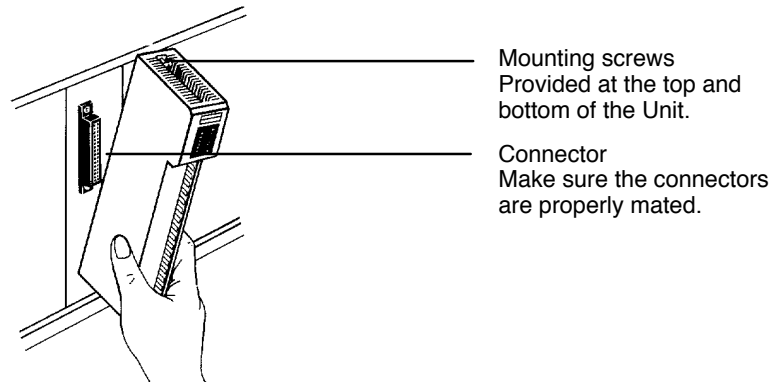

The following figure shows one I/O Unit mounted directly to the left of the CPU. Units other than the Power Supply Unit, the CPU, and the I/O Control Unit (see below) can be mounted to any of the other slots on the CPU Rack.

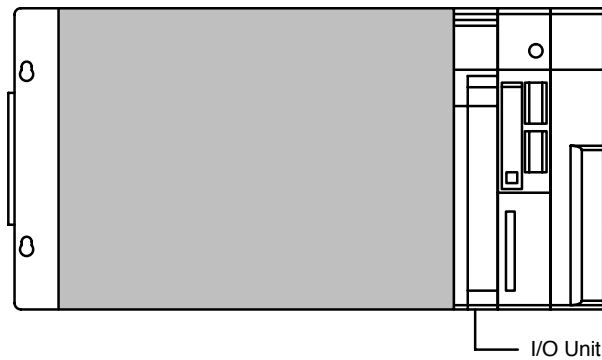

As you can see from the figure, there is still some space available to the left of the I/O Unit. This space is for any additional Units that may be required.

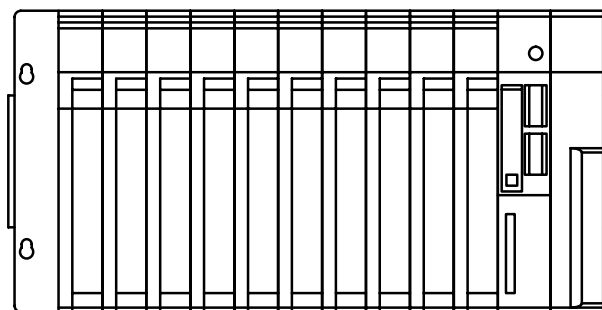

The figure above shows a total of ten I/O Units mounted to the Backplane. These I/O Units could be replaced by other Units, such as Special I/O Units, CPU Bus Units, etc. I/O Units come in five shapes; A-, B-, C-, D- and E-shape (refer to *Appendix B Specifications*) each of which can be mounted to any of the ten slots. The Backplane, Power Supply Unit, CPU, and other Units are collectively called a CPU Rack.

If we want to include more than ten Units in our configuration, we can add an additional Rack by mounting an I/O Control Unit to the leftmost slot of the CPU Rack.

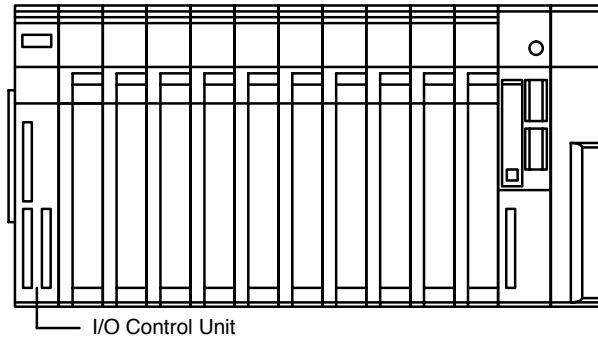

Now we can use a cable to connect the CPU Rack to another Rack. This Rack has a Power Supply Unit and I/O Units mounted to it, but it has no CPU of its own. The additional Rack must also have an I/O Interface Unit mounted to its leftmost slot to allow communications between the additional Rack and the CPU Rack. The Backplane, Power Supply Unit, I/O Interface Unit, and other Units are collectively called an Expansion I/O Rack or an Expansion CPU Rack. The differences between the various types of Rack and the types of Systems they can be used in are described in earlier sections of this manual. A CPU Rack connected to a single Expansion I/O Rack is shown below.

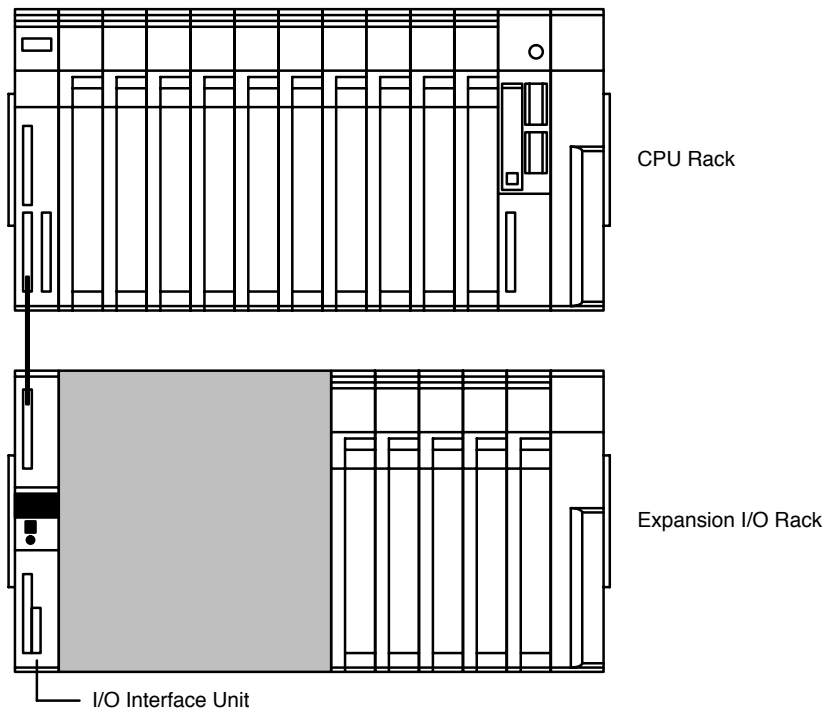

The CPU Rack and Expansion I/O Rack shown above are connected by a cable via the I/O Control Unit and I/O Interface Unit. It is possible to keep adding Expansion I/O Racks in this way until the maximum number of I/O points for the system is reached. Each Expansion I/O Rack requires an I/O Interface Unit, although a single Expansion I/O Rack can be connected by directly connecting the CPU and Expansion I/O Backplanes, as described in an earlier section.

3-1-2 Memory Card and Expansion Data Memory Unit

Extra memory is available in two forms, via the use of Memory Cards or by using an Expansion Data Memory Unit. This section outlines the procedure for mounting and removing these optional memory devices.

Memory Cards

The Memory Card can be used to store data and programs as files. Memory Cards are optional and are not supplied with the CPU. They must be ordered separately and installed by the user

Mounting a Memory Card

Mount a Memory Card to the CPU using the following procedure.

- 1, 2, 3...**
1. Open the cover of the Memory Card compartment.
 2. If the Memory Card is RAM or EEPROM, set the write-protect switch to OFF so that data can be written to the Card.
 3. Insert the Memory Card into its compartment. In doing so, a slight resistance will be felt as the connector on the Memory Card mates with the connector on the CPU. Continue pushing until the Memory Card is inserted completely into the CPU. If the Memory Card ON/OFF switch is ON, the Memory Card indicator will light.
 4. Close the cover.

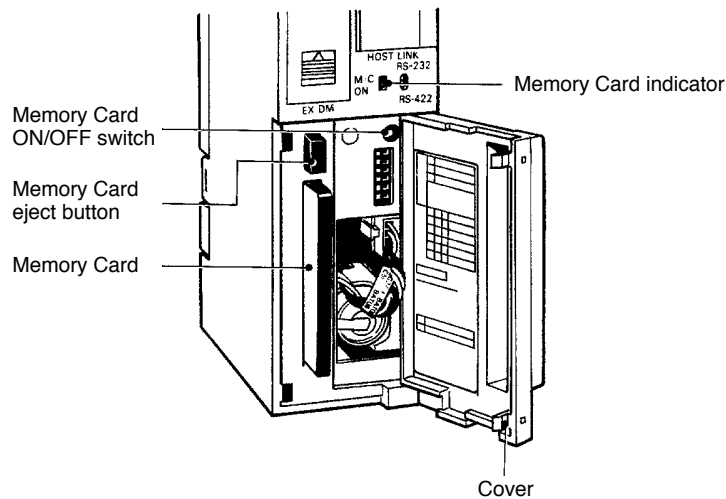

Removing a Memory Card

- 1, 2, 3...**
1. Open the cover of the Memory Card compartment.
 2. Press the Memory Card ON/OFF switch once if the Memory Card indicator is lit. The Memory Card indicator will turn OFF.
 3. Press the Memory Card eject button. The Memory Card will be released allowing it to be removed.
 4. Pull out the Memory Card.
 5. Close the cover.

- Note**
1. Do not expose the Memory Card to high temperature, humidity, or direct sunlight.
 2. Do not bend the Card or subject it to shock.
 3. Do not apply excess force to the Card when inserting or removing it.
 4. Do not remove the Card while the Memory Card indicator is lit; doing so may result in data errors in the memory.

Expansion Data Memory Unit

Mounting the Expansion Data Memory Unit

Mount the Expansion Data Memory Unit to the CV1000 CPU using the following procedure.

- 1, 2, 3... 1. Turn OFF the power to the PC.



Caution

Do not attempt to mount or remove the Memory Unit while the power to the PC is ON. During mounting or removal, exercise care that you do not directly touch the memory elements or connector pins of the Unit. Hold the Unit by the lever.

2. Remove the Expansion Data Memory Unit cover on the front panel of the CPU by pushing the lever on the cover upwards, as indicated by the arrow on the cover.

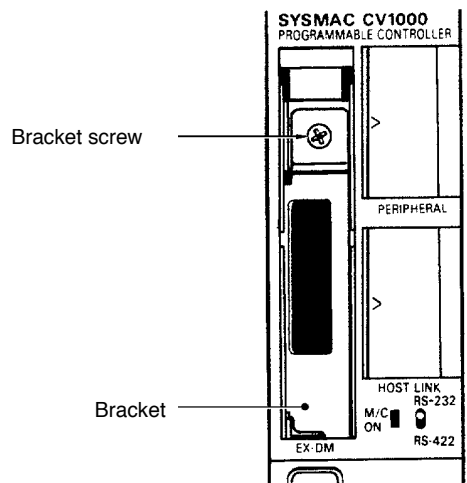

3. Loosen the bracket screw and remove the bracket.

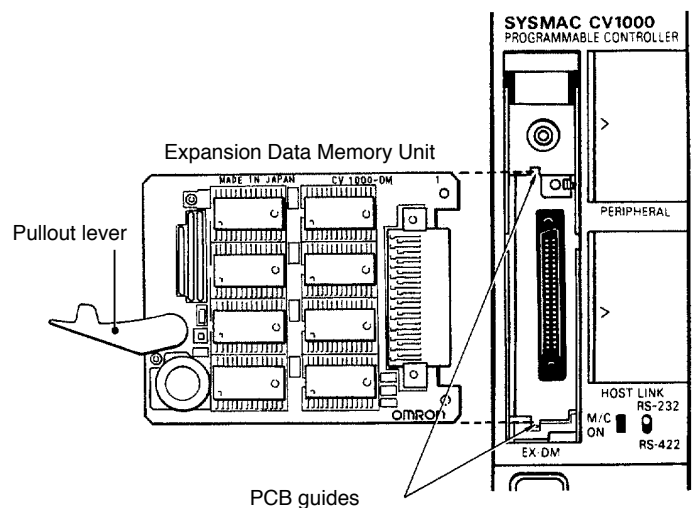

4. Hold the Expansion Data Memory Unit with the component side to the right, and insert the Unit into the PCB guides. In doing so, a slight resistance will be felt as the connector on the Memory Unit mates with the connector on the CPU. Continue pushing until the Memory Unit is inserted completely into the CPU.

5. Re-attach the bracket

Insert the bottom part of the bracket into the groove of the case and then press the bracket into place and tighten the bracket screw.

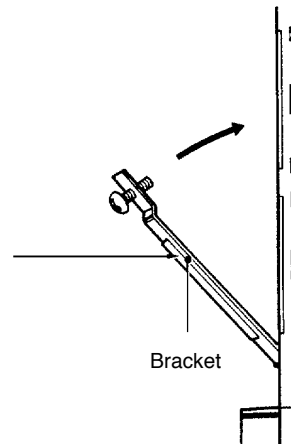

6. Attach the cover to the compartment.

When the Expansion Data Memory Unit is mounted to the CPU, the Expansion Data Memory Unit is backed up by the battery in the CPU.

When the Unit has been removed from the CPU, the memory contents will be retained for about 10 minutes by a backup capacitor built-in to the Unit, provided that CPU power was ON and that the Unit was mounted in the CPU for at least 1 minute.

When removing the Expansion Data Memory Unit, be sure to turn ON the power to the PC for more than 1 minute and then turn it OFF. At that time the capacitor will be fully charged allowing it to be backed up for 10 minutes. The retention period will be shorter if Memory Unit has been mounted (to the CPU) for less than 1 minute.

3-2 Installation Environment

This section details the necessary environmental conditions for installing the PC.

-  **Caution** Static electricity can damage PC components. Your body can carry an electrostatic charge, especially when the humidity is low. Before touching the PC, be sure to first touch a grounded metallic object, such as a metal water pipe, in order to discharge any static build-up.

Ambient Conditions

Do not install the PC in any of the following locations. Doing so will affect PC life and may affect operating performance.

- Locations subject to ambient temperatures lower than 0°C or higher than 55°C.
- Locations subject to drastic temperature changes or condensation.
- Locations subject to ambient humidity lower than 10% or higher than 90%.
- Locations subject to corrosive or flammable gases.
- Locations subject to excessive dust (especially iron dust) or chloride.
- Locations that would subject the CPU to direct shock or vibration.
- Locations that would subject the PC to water, oil, or chemical reagents.
- Locations exposed to direct sunlight.

Cooling

There are two points to consider in order to ensure that the PC does not overheat. The first is the clearance between the Racks, and the second is installation of a cooling fan.

Clearance between Racks

The Racks need to have sufficient room between each other to allow for I/O wiring, and additional room to ensure that the I/O wiring does not hamper cooling. The Racks must also be mounted so that the total length of the Connecting Cable between all Racks in a given series does not exceed 50 m. As a general rule, about 70 to 120 mm should be left between any two Racks. Consider factors such as the width of the wiring duct, wiring length, ventilation, and ease of access to Units, when determining the spacing between Racks. Greater space is required between Racks when using certain CPU Bus and Special I/O Units. Refer to the operation manuals for the Units you are using for details.

Cooling Fan

A cooling fan is not always necessary, but may be needed in some installations. Try to avoid mounting the PC in a warm area or over a source of heat. A cooling fan is needed if the ambient temperature may become higher than that specified. If the PC is mounted in an enclosure, install a cooling fan, as shown in the following diagram, to maintain the ambient temperature within specifications.

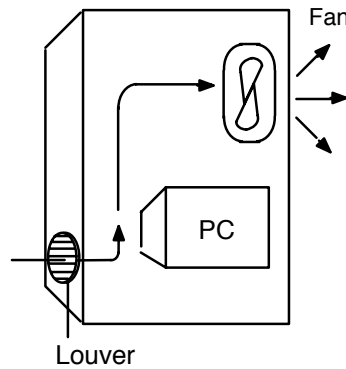

3-3 Mounting Racks

Each Rack must be mounted vertically, that is, with the printing on the front panels oriented as it would normally read. Racks may be directly mounted to any sturdy support meeting the environmental specifications.

Whenever possible, use wiring conduit to hold the I/O wiring. Standard wiring conduit should be used, and it should be long enough to completely contain the I/O wiring and keep it separated from other cables.

The duct work shown in the following diagram is not used for mounting the Racks. Although optional, this duct work can be used to house the wires from the I/O Units that run along the sides of the Racks, keeping the wires from becoming entangled. This figures illustrate the correct way to mount the Racks.

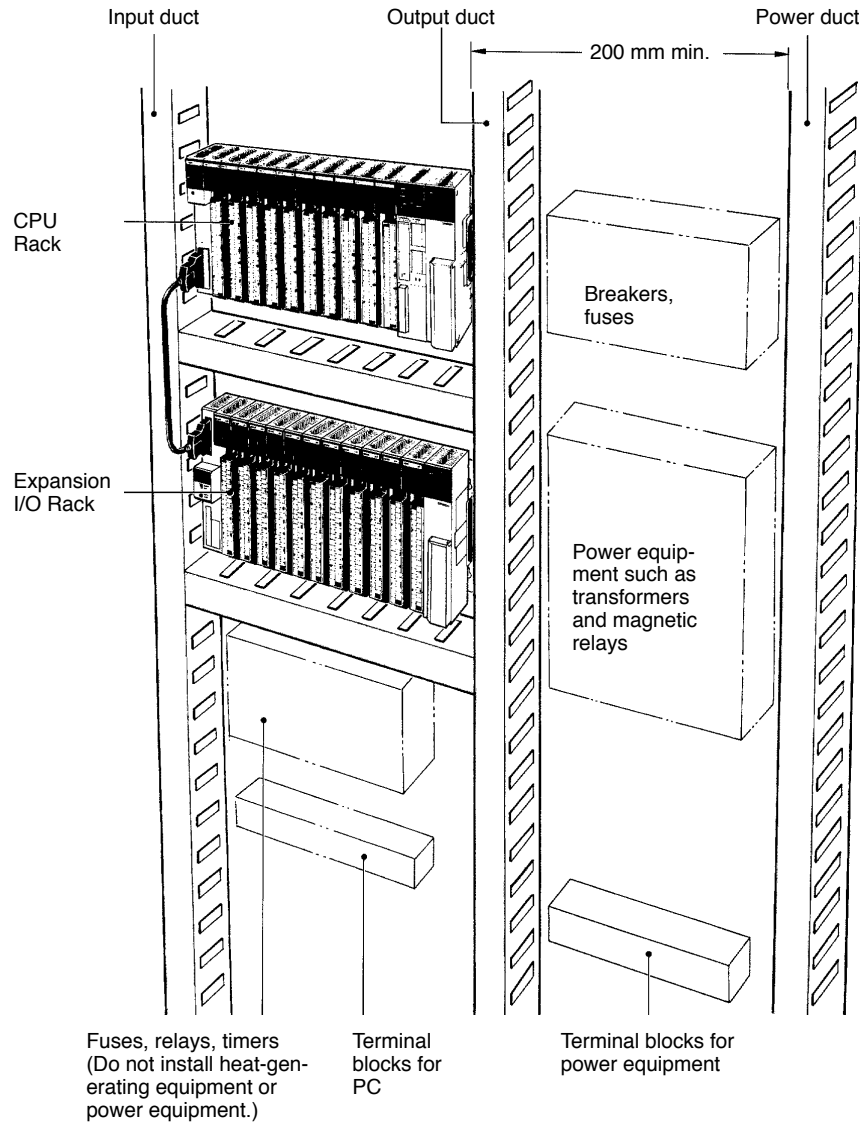

The following figure shows a side view of a mounted CPU and two Expansion I/O Racks. There should be a distance of 70 to 120 mm between the Racks. The total length of I/O cables connecting any one series of Expansion I/O Racks must be 50 m or less.

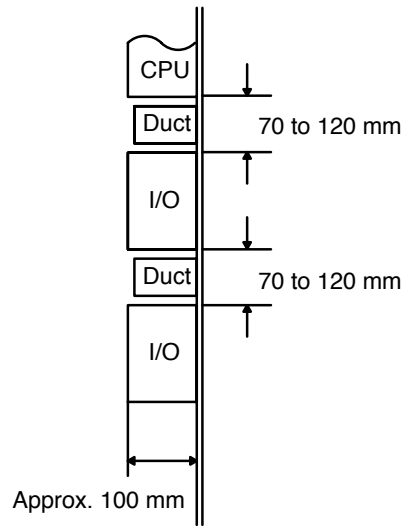

Do not mount the PC in a control panel in which high-power equipment is installed and make sure the point of installation is at least 200 mm away from power lines as shown in the following diagram. Ensure the plate to which the PC is mounted is grounded.

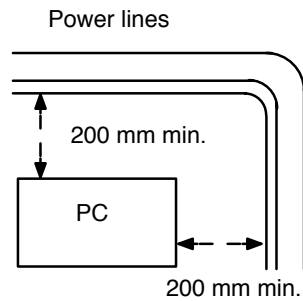

When mounting the PC in a control panel, mount the Racks to an intermediate plate. Holes for mounting the Racks to the intermediate plate should be drilled at intervals shown in the following diagram. Completely ground the intermediate mounting plates. Use conductor-plated plates to improve noise immunity.

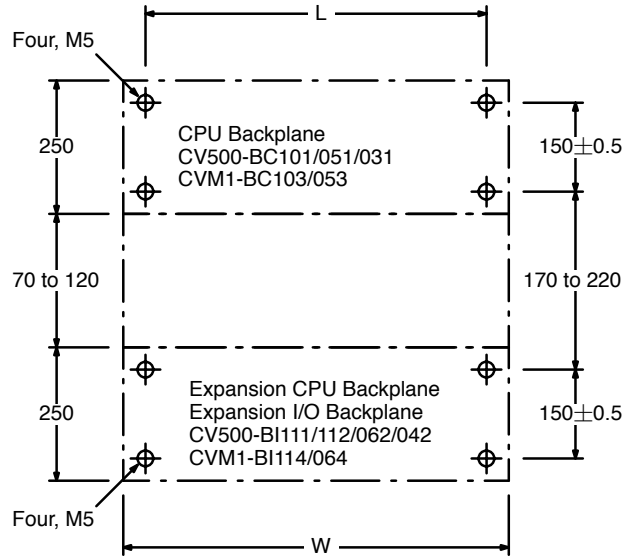

Model	W	L±0.5
CV500-BC101/BI111/112 CVM1-BC103/BI114	480	465
CV500-BC051/BI062 CVM1-BC053/BI064	306	291
CV500-BC031/BI042	236	221

3-3-1 Duct Work

If power cables carrying more than 10 A at 400 V or 20 A at 220 V must be run parallel to I/O wiring, leave at least 300 mm between the power cables and the I/O wiring, as shown in the following diagram.

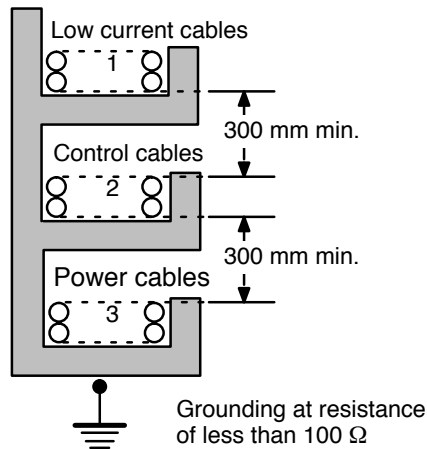

- 1 = I/O wiring
- 2 = General control wiring
- 3 = Power cables

If the I/O wiring and power cables must be placed in the same duct (for example, where they are connected to the equipment), shield them from each other using grounded metal plates. In addition, use shielded cables for the I/O signal lines to improve noise immunity. Also, connect the shielded cables to the ground (⊕) terminal of the PC.

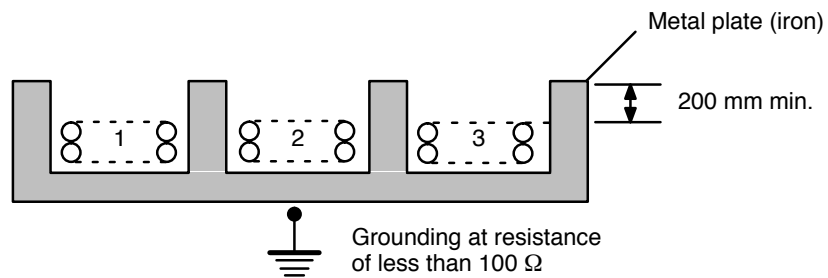

- 1 = I/O wiring
- 2 = General control wiring
- 3 = Power cables

3-4 Power Supply Units

Use a commercially available 100 to 120-VAC or 200 to 240-VAC power source to supply power to the AC Power Supply Unit; a 24-VDC power, for the DC Power Supply Unit. Expansion I/O Racks and Expansion CPU Racks must also be connected to a power source via a Power Supply Unit. If possible, use independent power sources for the Racks, input devices, and output devices.

Supply power to the CPU Rack and Expansion CPU Rack from the same power source. If supplied by separate sources or if power is not supplied to the Expansion CPU Rack, the CPU will not operate. It is also recommended that power to the Expansion I/O Racks be supplied from the same power source as the CPU and Expansion CPU Racks. In order to supply power to the Expansion I/O Racks from separate power sources, turn on the power to the Expansion I/O Racks before turning on power to the CPU Rack.

Supply power to the various parts of the system (power equipment, controls, PC system, and DC I/O, etc.) via separate power supplies.

3-4-1 Wiring the Power Source

The following diagrams show the proper way to connect the power source to the Power Supply Unit. The terminals marked “NC” are not connected internally.

AC Power Supply Units: CV500-PS221/CVM1-PA208

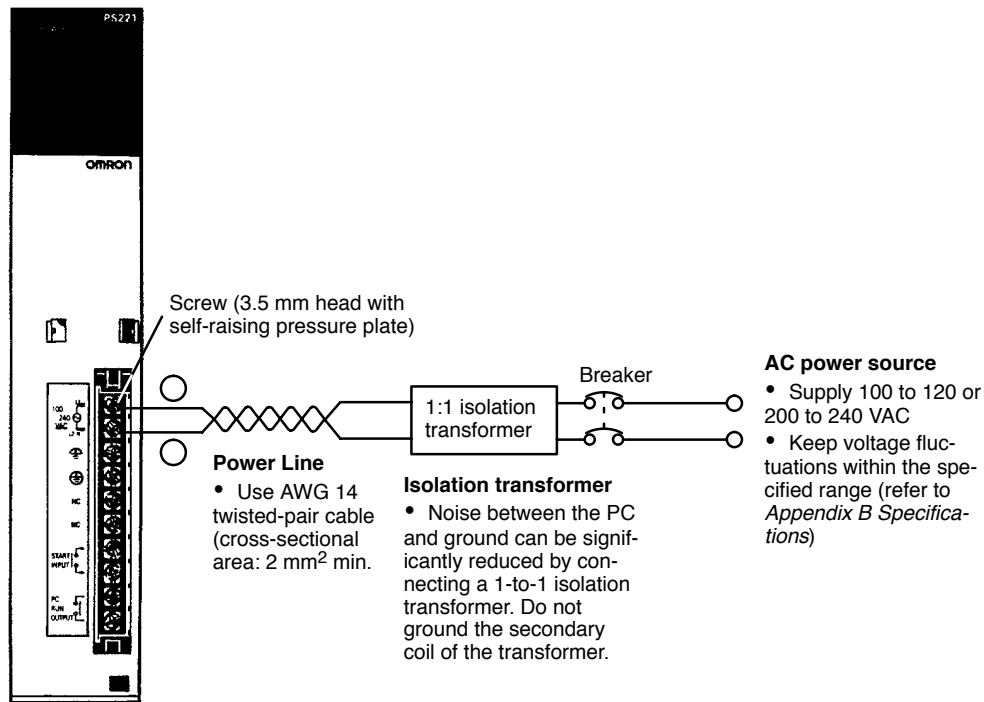

Use round crimp terminals for wiring. Do not connect bare stranded wires directly to terminal blocks. Use M3.5 screws for tightening crimp terminals.



Caution Tighten the screws on the terminal block of the AC Power Supply Unit to a torque of 0.8 N • m. The loose screws may result in short-circuit, burning, or malfunction.

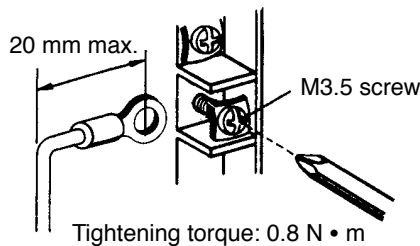

WARNING Do not allow your hands or any other part of your body, or any object in contact with your body, to come into contact with the AC power supply section after power has been turned on. Contact with the power supply section will result in a dangerous or fatal electrical shock.

Caution Abide by the following precautions when wiring the Power Supply Units. Failure to abide by these precautions may cause faulty operation or damage to the Unit.

- Be sure that no wire clippings or other foreign materials enter the Units when wiring.
- Provide circuit breakers and other protective devices to protect the system against external short circuits.
- Check and recheck all wiring before supplying power to the system.
- After wiring the terminals check the terminal block to be sure it is firmly locked in place.

Power Requirements

A CV-series PC consumes up to 200 VA per Rack. Power consumption varies with the system configuration (refer to 3-4-6 *Current Consumption*). When power is applied, a surge current five times the steady-state current will flow to the PC.

DC Power Supply Units: CV500-PS211

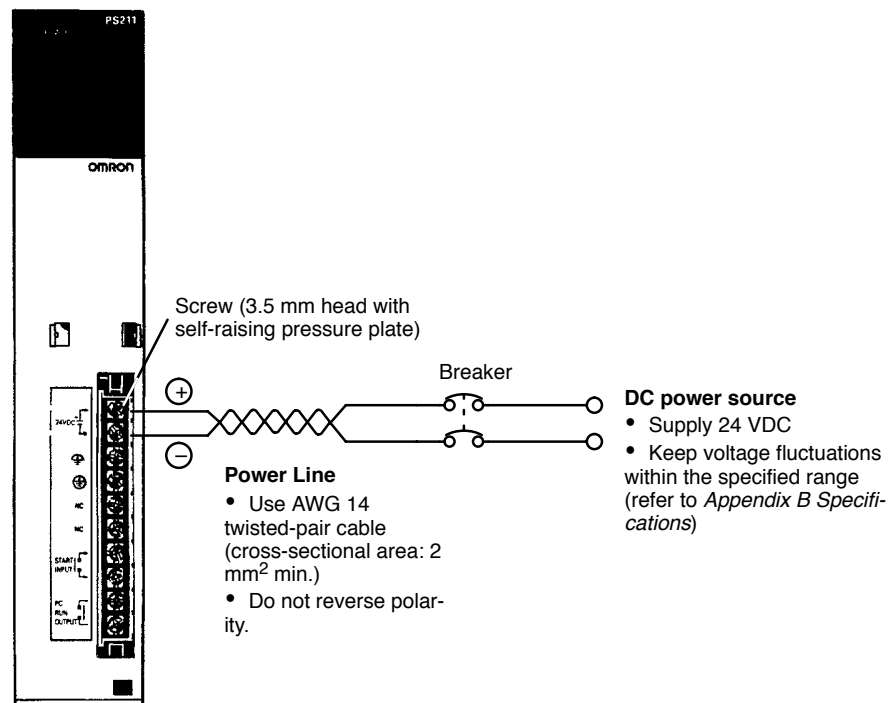

Power Requirements

A CV-series PC can consume up to 100 W of power per Rack. Power consumption varies depending on the system configuration (refer to 3-4-6 *Current Consumption*). When power is applied, a surge current several times the steady-state current will flow to the PC.

Internal Fuse

Do not turn on power to the DV Power Supply Unit while the 5-V output terminals are closed. If power is supplied when the 5-V output terminals are closed, the internal fuse may blow.

Surge Current

The surge current for the DC Power Supply Unit under maximum load conditions is shown below. Consider the surge current characteristics when selecting the power source, switches, breakers, etc.

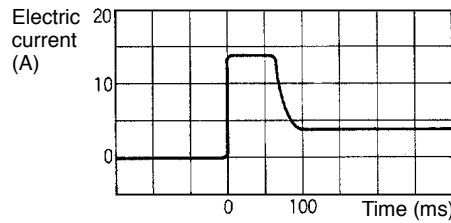

Input: 24 VDC; load: 12 A at 5 V (maximum load); ambient temp.: 25°C.

Use crimp terminals for wiring. Do not connect bare stranded wires directly to terminal blocks. Use M3.5 screws for tightening crimp terminals.



Tighten the screws on the terminal block to a torque of 0.8 N • m.

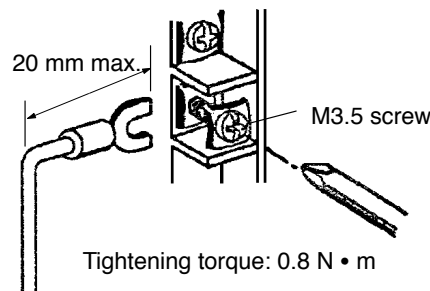

⚠ Caution Abide by the following precautions when wiring the Power Supply Units. Failure to abide by these precautions may cause faulty operation or damage to the Unit.

- Be sure that no wire clippings or other foreign materials enter the Units when wiring.
- Provide circuit breakers and other protective devices to protect the system against external short circuits.
- Check and recheck all wiring before supplying power to the system.
- After wiring the terminals check the terminal block to be sure it is firmly locked in place.

3-4-2 Grounding

The line ground (LG: ⚡) terminal of the Power Supply Unit is a noise-filtered neutral terminal. Short the line ground terminal to the ground (GR: ⚡) terminal to improve noise resistance.

To avoid electrical shock, attach a grounded AWG 14 wire (cross-sectional area of 2 mm²) to the ground terminal. The ground resistance must be 100 Ω or less and must be checked periodically to be sure that environmental conditions have not deteriorated ground capacity. Do not use a wire longer than 20 m.

PC operation may be adversely affected if the ground wire is shared with other equipment or if the ground wire is attached to the metal structure of a building. When using Expansion I/O Racks, the Racks must also be grounded to the ground terminal. The same ground can be used for all Racks.

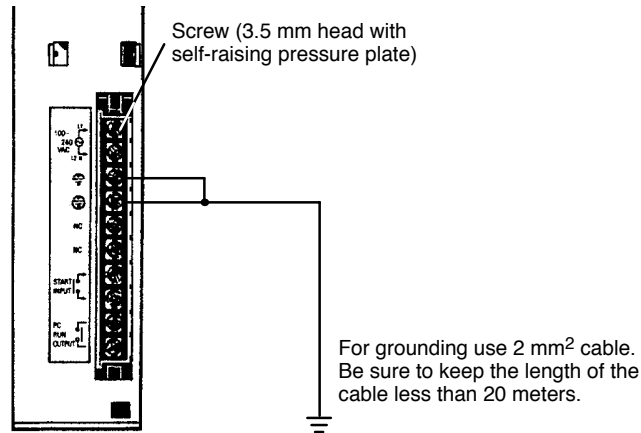

Use crimp terminals for wiring. Do not connect bare stranded wires directly to terminal blocks. Use M3.5 screws for tightening crimp terminals.



Tighten the screws on the terminal block to a torque of 0.8 N • m.

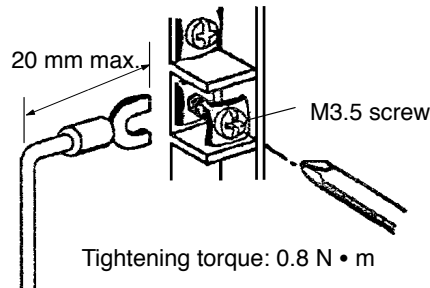

WARNING Always attach crimp terminals to the ground lines to ensure proper connection. Connecting loose wires can cause fires.

Caution

- Ground the Power Supply Units separately from other devices.
- After wiring the terminals check the terminal block to be sure it is firmly locked in place.

Note If you suspect that grounding is the cause of operational errors, either disconnect the line ground and ground terminals and either ground the mounting plate or try operating with no ground at all.

3-4-3 Wiring Other Terminals

The Power Supply Units provide a START input and a RUN output. These terminals can be used to help control system operation.

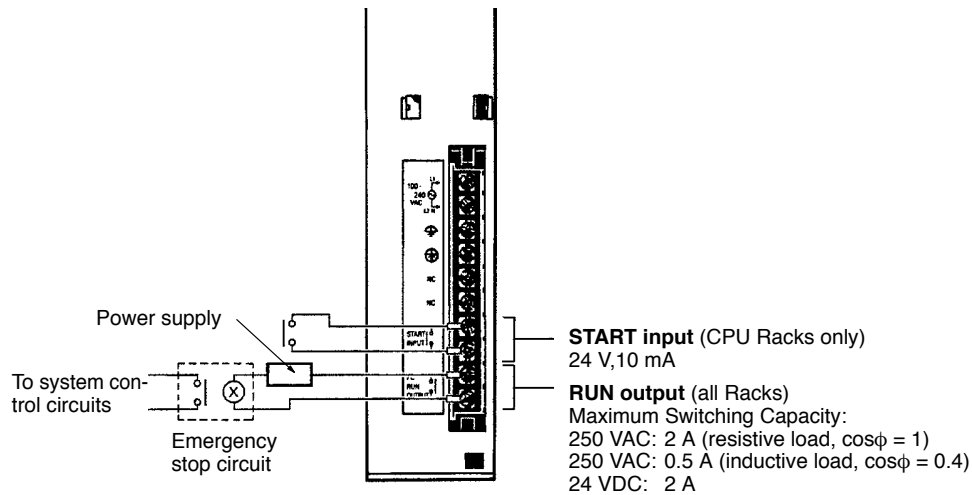

- Note**
1. Use reinforced insulation or double insulation on the DC power supply connected to CV500-PS211 Power Supply Unit when complying with EC directives (low voltage).
 2. The maximum switching capacity of the CV500-PS211 Power Supply Unit is 2 A at 24 VDC when complying with EC Directives (low-voltage directives).

START Input

The START input terminals are short-circuited at the factory with a short bar. The short bar can be removed and the terminals wired to a 10-mA, 24-VDC external input to control PC operation. When these terminals are open, PC operation will stop.

RUN Output

The RUN output terminals will be ON (closed) when the PC is operating in RUN or MONITOR mode. These terminals can thus be wired to provide an external signal indicating the operating status of the PC, such as is used in the emergency stop circuit in the next section.

Use round crimp terminals for wiring. Do not connect bare stranded wires directly to terminal blocks. Use M3.5 screws for tightening crimp terminals.



⚠ Caution Tighten the screws on the terminal block of the AC Power Supply Unit to a torque of $0.8 \text{ N} \cdot \text{m}$. The loose screws may result in short-circuit, burning, or malfunction.

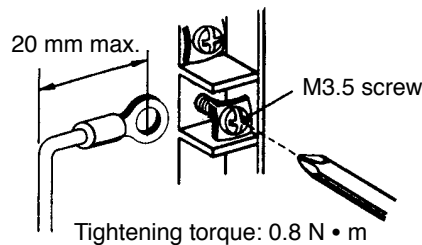

⚠ WARNING Always attach crimp terminals to the wires to ensure proper connection. Connecting loose wires can cause fires.

⚠ Caution Abide by the following precautions when wiring the Power Supply Units. Failure to abide by these precautions may cause faulty operation or damage to the Unit.

- Be sure that no wire clippings or other foreign materials enter the Units when wiring.
- Check and recheck all wiring before supplying power to the system.

Note The RUN output on Slave Racks will go OFF when a remote I/O error occurs.

3-4-4 Emergency Stop

You can use an external relay (CR in the following figure) to form an emergency stop circuit that shuts down the system when PC operation stops. This can be achieved by wiring the RUN output from the Power Supply Unit on the CPU Rack as shown below.

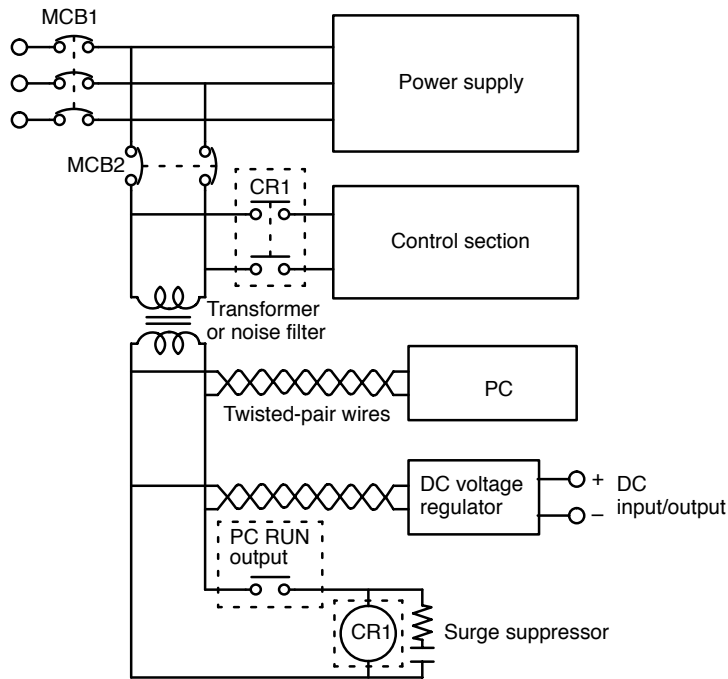

3-4-5 Power Interruptions

A sequence circuit is built into the PC to handle power interruptions. This circuit prevents malfunctions due to momentary power loss or voltage drops. A timing diagram for the operation of this circuit is shown below.

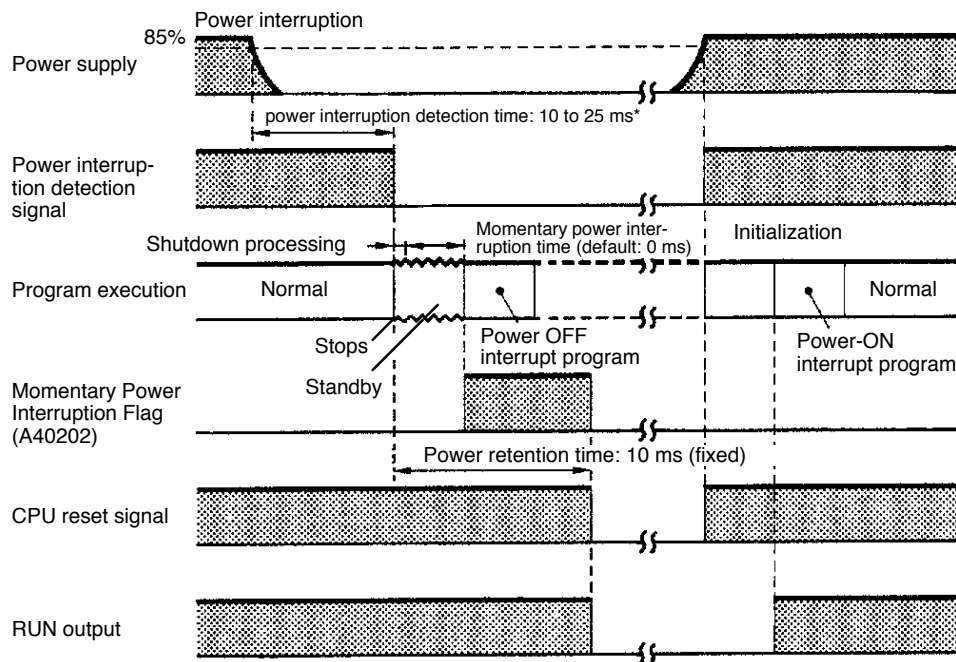

*0.3 to 1 ms for DC power.

The PC ignores all momentary power interruptions if the interruption lasts no longer than 10 ms. If the interruption lasts between 10 and 25 ms, the interruption may or may not be detected. If the supply voltage drops below 85% of the rated voltage for longer than 25 ms (less for the DC Power Supply Unit), a power interruption detection signal is output and program execution is halted.

If power is not restored within 10 ms (the power retention time) after the power interruption detection signal is output, the PC stops operating and all outputs are turned OFF.

If after power interruption detection, power is restored within a period defined as the momentary power interruption time (default value: 0 ms), the CPU will resume operation. If the momentary power interruption time elapses and power has not been restored, the CPU will begin execution of the power OFF interrupt program if one has been programmed. The CPU stops operating after the lapse of the power retention time (10 ms).

Note The momentary power interruption time can be set to between 0 and 10 ms. For details, refer to the *CVSS Operation Manuals*.

 **Caution** If a C500 Expansion I/O Rack is connected to the PC, the momentary power interruption time setting is not effective and a power interruption of any length will trigger shut down processing.

Automatic Recovery Operation is resumed automatically when the voltage is restored to more than 85% of the rated value.

3-4-6 Current Consumption

The Power Supply Units are limited in the total current they can supply to Units on the Racks. The following table shows the maximum current available on a Rack for either model of Power Supply Unit. The available current shown in the table is in addition to the current consumed by the Backplane, Power Supply Unit, CPU, I/O Control Unit, I/O Interface Unit, and Peripheral Devices.

Rack		CV500-PS221/211	CVM1-PA208
CPU Rack	CV500 or CVM1-CPU01-EV2	9.8 A max.	5.8 A max.
	CV1000, CV2000, CVM1-CPU11-EV2, or CVM1-CPU21-EV2	9.4 A max.	5.4 A max.
Expansion CPU Rack		11 A max.	7 A max.
Expansion I/O Rack		11 A max.	7 A max.

Calculate the current requirements for the Units on each Rack by adding up the current consumption of each Unit mounted, excluding the Power Supply Unit, CPU, I/O Control Unit, I/O Interface Unit, Remote I/O Slave Units, and Peripheral Devices (the power requirements for these Units have already been allowed for). The total must not exceed the limit given above for the Rack.

The current consumption for the Expansion I/O Rack does not include the current consumed by peripheral devices. The current consumed by peripheral devices attached to the Expansion I/O Rack must be included when calculating the total current consumption.

Input Units

Units	Model	Consumption (A)
DC Input	3G2A5-ID112	0.01
	3G2A5-ID114	0.34
	3G2A5-ID213	0.02
	3G2A5-ID215	0.16
	3G2A5-ID218	0.26
	C500-ID218CN	0.2
	3G2A5-ID212	0.3
	3G2A5-ID219	0.34
Interrupt Input Unit	3G2A5-ID216	0.2
AC Input	3G2A5-IA121	0.18
	3G2A5-IA222	0.18
	C500-IA223	0.18
	3G2A5-IA122	0.18
TTL Input	C500-ID501CN	0.2
AC/DC Input	3G2A5-IM211	0.01
	3G2A5-IM212	0.2

Output Units

Units	Model	Consumption (A)
Contact Output	3G2A5-OC221	0.1
	3G2A5-OC223	0.1
	3G2A5-OC224	0.2
Transistor Output	3G2A5-OD411	0.16
	3G2A5-OD215	0.2
	3G2A5-OD412	0.23
	C500-OD414	0.23
	3G2A5-OD212	0.23
	3G2A5-OD211	0.3
	3G2A5-OD213	0.46
	C500-OD217	0.16
	C500-OD218	0.23
	C500-OD219	0.16
	C500-OD415CN	0.23
Triac Output	3G2A5-OA121	0.3
	3G2A5-OA222	0.3
	3G2A5-OA223	0.45
	C500-OA225	0.2
	C500-OA226	0.45
TTL Output	C500-OD501CN	0.25
DC Input/Transistor Output	C500-MD211CN	0.26
Dummy I/O	3G2A5-DUM01	0.035

Special I/O Units

Unit	Model	Consumption (A)
Analog Input	3G2A5-AD001 to- AD005	0.3
	3G2A5-AD006/007	0.75
	C500-AD101	0.88
	C500-AD501	1.2
Analog Output	3G2A5-DA001 to -DA005	0.55
	C500-DA101	1.3
High-speed Counter	3G2A5-CT001	0.3
	3G2A5-CT012	0.55
	C500-CT021	0.35
	C500-CT041	1.0
Magnetic Card Reader	3G2A5-MGC01-E	1.0
PID	3G2A5-PID01-E	1.4
Position Control	3G2A5-NC103-E	Total 1.4
	3G2A5-TU001	
	3G2A5-NC111-EV1	Total 1.0
	3G2A5-TU001	
	3G2A5-NC121-E	Total 1.7
	3G2A5-TU001	
	C500-NC222-E	Total 1.3
	3G2A5-TU002	
Cam Positioner	C500-CP131	0.8
Voice	C500-OV001	0.35
ASCII	C500-ASC04	0.5
ID Sensor	C500-IDS□□	0.4
Ladder Program I/O	3G2A5-LDP01-V1	0.8

Link Units

Unit	Model	Current Consumption (A)
SYSMAC NET Link	CV500-SNT31	0.9
SYSMAC LINK	CV500-SLK11/22	0.5
SYSMAC BUS/2 Remote I/O Master	CV500-RM211/221	0.5
CompoBus/D Master Unit	CVM1-DRM21	0.25
Host Link Unit	CV500-LK201	0.6
Ethernet Unit	CV500-ETN01	1.7
BASIC	CV500-BSC11/21	0.5
	CV500-BSC51/61	
	CV500-BSC31/41	0.3
Personal Computer Unit	CV500-VP□□□-E	2.3
Temperature Controller Data Link Unit	CV500-TDL21	0.5
Remote I/O Master	3G2A5-RM001-(P)EV1	0.7
	C500-RM201	0.3
I/O Link	3G2A5-LK010-(P)E	0.6

3-5 Wiring I/O Units

Connect the I/O Devices to the I/O Units using AWG 22 lead wire (cross-sectional area: 0.3 mm²) for 19-terminal terminal blocks and AWG 22 to 18 lead wire (cross-sectional area: 0.3 to 0.75 mm²) for 10-terminal terminal blocks. The terminals have screws with 3.5-mm diameter heads and self-raising pressure plates. Connect the lead wires to the terminals as shown. Tighten the screws to a torque of 0.8 N • m.

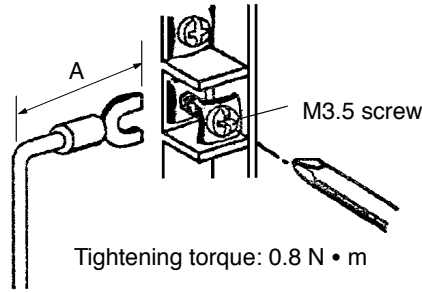

Terminal block	A
20-terminal Terminal block	25 mm max.
38-terminal Terminal block	16.5 mm max.

Use crimp terminals for wiring. Do not connect bare stranded wires directly to terminal blocks. Use M3.5 screws for tightening crimp terminals.



WARNING Always attach crimp terminals to the wires to ensure proper connection. Connecting loose wires can cause fires.

Caution Abide by the following precautions when wiring the I/O Units. Failure to abide by these precautions may cause faulty operation or damage to the Unit.

- Be sure that no wire clippings or other foreign materials enter the Units when wiring.
- Check and recheck all wiring before supplying power to the system.
- Check and recheck terminal block before mounting them to the Unit.

- Note**
1. Putting I/O lines and high-tension lines or power lines in the same duct or conduit may cause the I/O lines to be affected by noise. This may cause a malfunction in the Unit or may damage the Unit or I/O devices.
 2. Use reinforced insulation or double insulation on the DC power supply connected to DC I/O Units when complying with EC directives (low voltage).
 3. Use separate power supplies for Relay Output Units and DC I/O Units when complying with EC directives (low voltage).

3-5-1 Terminal Blocks

The terminal block of an I/O Unit can be removed by loosening the mounting screws. You do not have to remove the lead wires from the terminal block in order to remove the block from an I/O Unit.

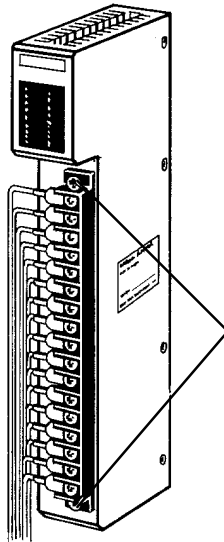

Terminal block mounting screws

Loosen the terminal block mounting screws to remove the terminal block from the I/O Unit. Make sure the mounting screws on the terminal block are tightened after wiring is complete and the terminal block is re-mounted to the I/O Unit.

3-5-2 Wiring Precautions

General

Electrical Noise

Take appropriate measures when any electrical device likely to produce noise is connected to the PC as a load. Devices generating noise of more than 1,200 V (such as electromagnetic relays and valves) require noise suppression. For noise sources running on DC power, connect a diode in parallel with the coil of each device.

When mounting a CPU Rack and an Expansion I/O Rack together on a mounting plate, provide a ground to the mounting plate. The mounting plate must be plated with a highly conductive surface in order to ensure noise immunity.

Inductive Load Surge Suppressor

When an inductive load is connected to an I/O Unit, connect a surge suppressor or diode in parallel with the load, as shown in the following diagram. The diode will adsorb the back electromagnetic field generated by the load.

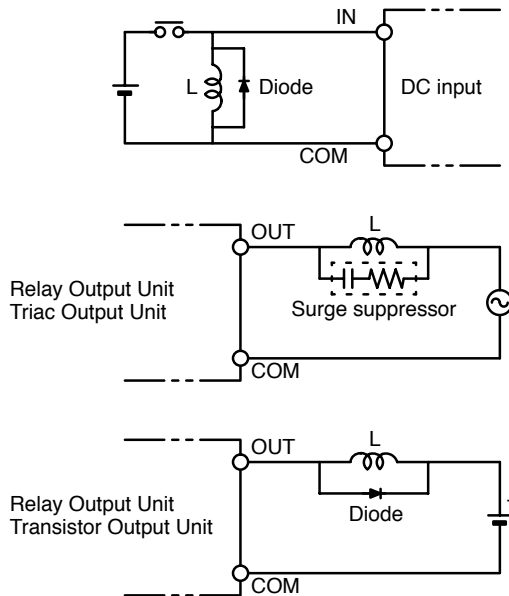

where for the surge suppressor,
 Resistor: 50 Ω
 Capacitor: 0.47 F
 Voltage: 200 V

and the diode,
 Breakdown voltage: at least 3 times load voltage
 Mean rectification current: 1 A

Input Units

Voltage Inputs

Do not wire voltage inputs as shown on the left below.

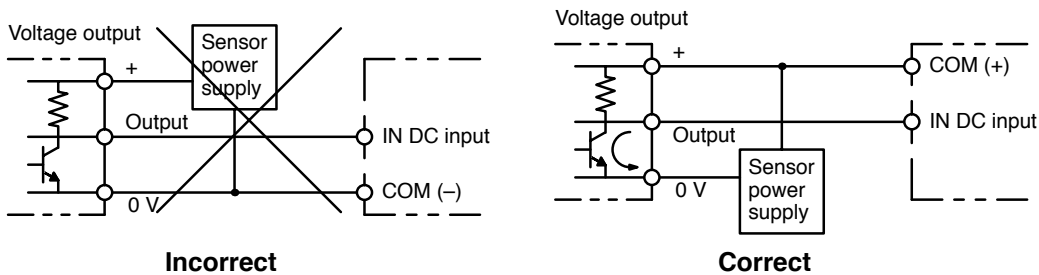

Input Leakage Current

When two-wire sensors, such as photoelectric sensors, proximity sensors or limit switches with indicators are connected to the PC as input devices, the input bit may be turned ON erroneously by leakage current. In order to prevent this, connect a bleeder resistor across the input to reduce the input impedance.

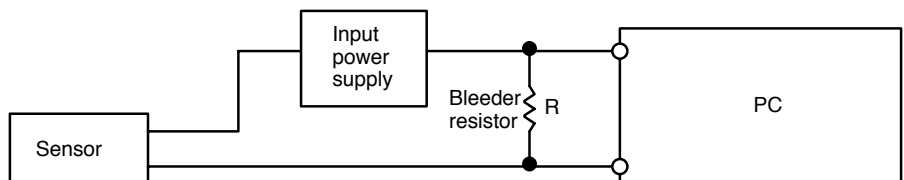

If the leakage current is less than 1.3 mA, there should be no problem. If the leakage current is greater than 1.3 mA, determine the value and rating for the bleeder resistor using the following formulas.

I = leakage current in mA
 $R = \frac{7.2}{2.4 \times I - 3} \text{ k}\Omega \text{ max.}$
 $W = \frac{2.3}{R} \text{ W min.}$

where
 I = leakage current in mA
 R = Bleeder resistance ($\text{k}\Omega$)
 W = Bleeder resistor wattage (W)

Output Units

Output Short Protection

Output devices and Output Units can be damaged if the load connected to an output terminal is shorted. Attach a fuse to the output circuit to protect your system. A fuse is recommended even if the Output Unit is provided with an internal fuse (e.g., Transistor and Triac Output Units), to increase ease of maintenance and provide extra protection.

Interlock Circuits

When the PC controls an operation such as the clockwise and counterclockwise operation of a motor, provide an external interlock such as the one shown below to prevent both the forward and reverse outputs from turning ON at the same time.

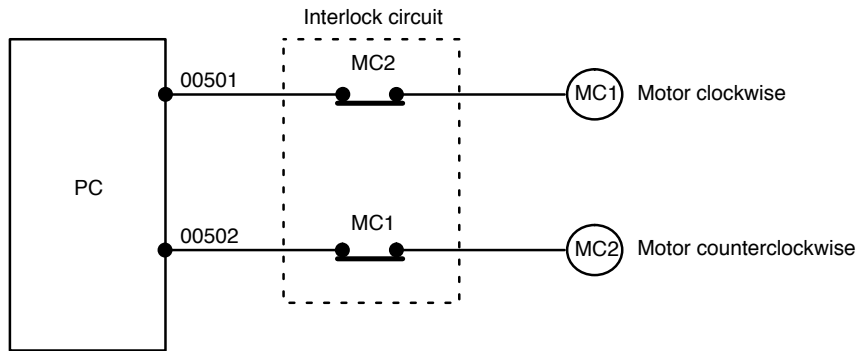

This circuit prevents outputs MC1 and MC2 from both being ON at the same time. Even if the PC is programmed improperly or malfunctions, the motor is protected.

Output Leakage Current

If a transistor or triac Output Unit is used to drive a low voltage load, the leakage current may prevent the output device from turning OFF. To prevent this, connect a bleeder resistor in parallel with the load as shown in the following table.

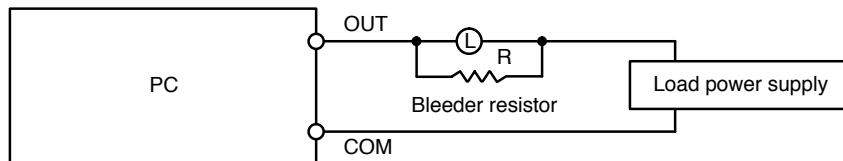

Select the bleeder resistor using the following formula.

$$R < \frac{E_{ON}}{I}$$

where
 I = leakage current in mA
 R = Bleeder resistance ($\text{k}\Omega$)
 E_{on} = ON voltage of the load

Output Surge Current

When connecting a Transistor or Triac Output Unit to an output device having a high surge current (such as an incandescent lamp), care must be taken to avoid damage to the Output Unit. The Transistor and Triac Output Units are capable of withstanding a surge current of ten times the rated current. If the surge current for a particular device exceeds this amount, use one of the following circuit configurations to protect the Output Unit.

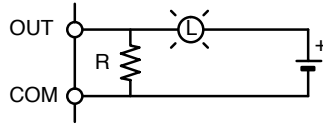

The above circuit protects the Output Unit by letting the load draw a small current (about one third the rated current) while the output is OFF, significantly reducing the surge current. The following circuit reduces the surge current by employing a current-limiting resistor.

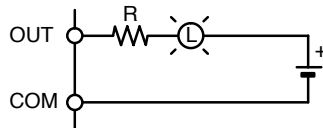

Transistor Output Residual Voltage

A Transistor Output Unit's output cannot be directly connected to a TTL input because of the transistor's residual voltage. When connecting TTL circuits to transistor Output Units, connect a pull-up resistor and a CMOS IC between the two.

3-5-3 Wiring Examples

The following examples illustrate how to connect I/O devices to I/O Units. During wiring, work slowly and carefully. If an input device is connected to an Output Unit, damage may result. Check all I/O devices to make sure they meet the specifications (refer to *Appendix B Specifications*). Be sure to allow for leakage currents and load inductance.

Input Units

DC Input Units

Contact output

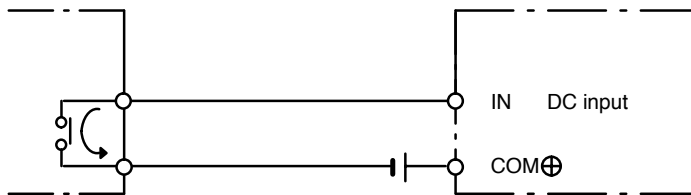

Sensor Inputs

When using the following configurations, the sensor and Input Unit should receive their power from the same source.

NPN current output



NPN open-collector output

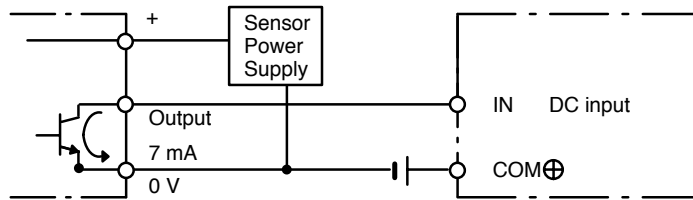

PNP current output

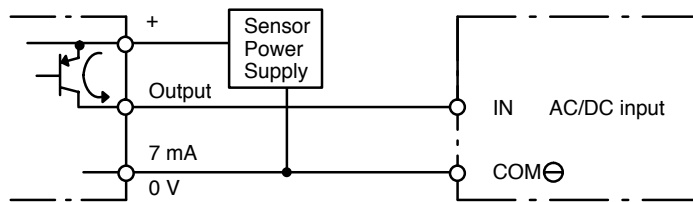

AC Inputs

Contact output

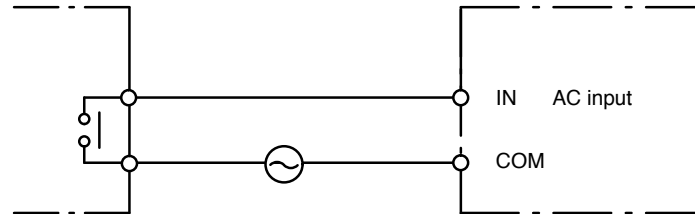

AC Switching

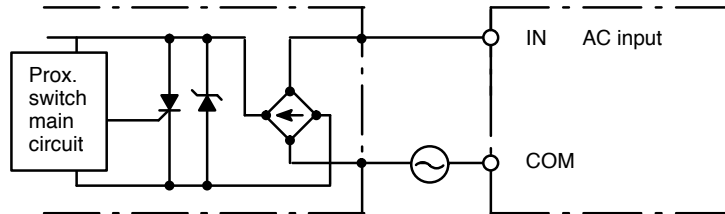

3-6 Compliance with EC Directives

The following precautions must be abided by when installing CV-series PCs to meet EC Directives.

- 1, 2, 3... 1. CV-series PCs are classified as open-structure devices and must be installed inside a control panel.
2. Use reinforced insulation or double insulation on the DC power supply connected to CV500-PS211 Power Supply Unit and DC I/O Units.
3. Use separate power supplies for Relay Output Units and DC I/O Units.

4. The maximum switching capacity of the CV500-PS211 Power Supply Unit is 2 A at 24 VDC when complying with EC Directives (low-voltage directives).
5. CV-series PCs that meet EC Directives meet the common emission standard (EN50081-2) of the EMC Directives as individual products. When assembled into machinery, however, the noise generated by switching relay outputs can fail to meet the standard. When noise is excessive, surge killers must be installed or other measures must be taken outside of the PC. The measures required to meet the standard will vary with the load being driven, wiring, the configuration of the machinery, etc.

The following examples show means of reducing noise. These means will only reduce the amount of noise and will not eliminate noise. They are provided here as examples only.

Requirement

The following conditions can be used to determine if measures to reduce noise are necessary. Refer to the EN50081-2 Standard for details.

- If the loads of the devices into which the PC is built are switched less than 5 times a minute, then no measures need to be taken.
- If the loads of the devices into which the PC is built are switched 5 times or more a minute, then measures need to be taken.

Examples

Inductive Load Surge Suppressor

Connect a surge suppressor or diode in parallel with the load, as shown in the following diagrams, when switching inductive loads.

CR Method (AC or DC)

The reset time will be increased if the load is a relay, solenoid, or similar device. Connect the CR between the load connections for 24-V and 48-V power supply voltages and between the contact connections for 100 to 200-V power supply voltages.

The capacitor and resistors can be based on the following guidelines.

C: 0.5 to 1 μF for each amp of contact current

R: 0.5 to 1 Ω for each volt of contact voltage.

You will need to adjust the above values depending on the characteristics of the load, relay, etc., based on the discharge suppression of the capacitor when the contacts are open and the current control effect of the resistor the next time the circuit is closed.

The dielectric strength of the capacitor generally needs to be between 200 and 300 V. Use an AC capacitor (without polarity) in an AC circuit.

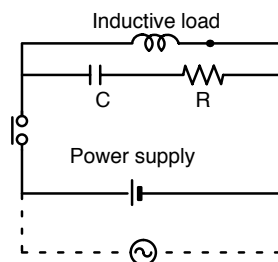

Diode Method (DC Only)

The energy stored in the coil is impressed on the coil as a current by the action of the parallel diode and converted to Joule heat by the resistance of the inductive load. Here, the reset time will be increased even more than for the CR method.

The reverse dielectric strength of the diode must be 10 times the circuit voltage and the forward current must be at least as high as that of the load. If the circuit voltage is low enough, as it is for most electronic circuits, then the reverse dielectric strength of the diode can be as low as 2 to 3 times the circuit voltage.

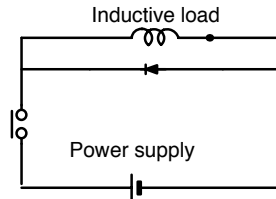

Varistor (AC or DC)

The method uses the fixed voltage characteristics of a varistor to prevent high voltages from being applied to the contacts. Here, as well, the reset time will be increase somewhat.

Connect the varistor between the load connections for 24-V and 48-V power supply voltages and between the contact connections for 100 to 200-V power supply voltages.

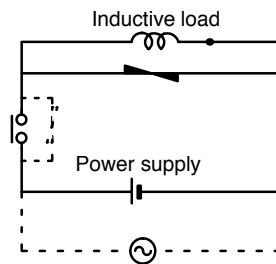

Output Surge Current

When connecting an output device having a high surge current (such as an incandescent lamp), use one of the following circuit configurations to protect the Output Unit.

The following circuit lets the load draw a small current (about one third the rated current) while the output is OFF, significantly reducing the surge current.

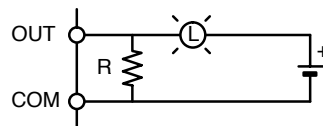

The following circuit reduces the surge current by employing a current-limiting resistor.

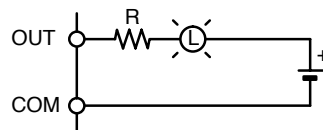

SECTION 4

Inspection and Maintenance

This section describes the procedures necessary for periodic inspection and maintenance. Always keep spare items on hand so that they can be used as immediate replacements.

- 4-1 CPU Battery
- 4-2 Memory Card Battery
- 4-3 Output Unit Fuses
- 4-4 Output Unit Relays

4-1 CPU Battery

When the battery is nearly discharged, the ALARM indicator will blink, bit A42615 will turn ON, and the message “BATT LOW” will appear on the Programming Device. When this occurs, replace the battery within one week to avoid loss of data. The battery and connector are provided as a set. To replace the Battery Set, follow the steps below. The entire replacement must be completed within five minutes to ensure that the data will not be lost.

Caution Do not short circuit, charge, disassemble, or expose the battery to heat. The battery fluid is flammable and if mishandled, may cause a fire or explosion. Do not incinerate the battery after use.

The expected life of the battery is 5 years for any CPU. The memory backup times are given in the following table.

Model	Backup time without power supplied	
	Guaranteed value	Effective value
CV500 or CVM1-CPU01-EV2	9,000 hours (approx. 1 year)	43,000 hours (approx. 5 years)
CV1000/CV2000/CVM1-CPU21-EV2 without Expansion DM or CVM1-CPU11-EV2	5,600 hours (approx. 0.6 year)	
CV1000/CV2000/CVM1-CPU21-EV2 with Expansion DM	2,900 hours (approx. 0.3 year)	

Guaranteed value: Memory backup time without power supplied at 55°C.

Effective value: Memory backup time without power supplied at 25°C.

Battery Replacement

1, 2, 3...

1. Turn on power to the PC for at least one minute.
2. Turn off power to the PC. (Although the battery can be replaced while power is being applied to the PC, it is not recommended, as short-circuiting is likely to occur.)
3. Remove the cover from the battery compartment.
4. Remove the old Battery Set.
5. Install the new Battery Set as shown below.

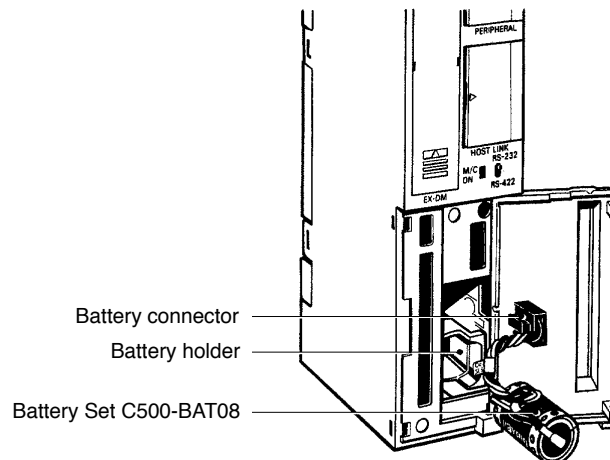

6. Replace the cover of the battery compartment.
7. When a Programming Console is mounted to the CPU after the battery has been replaced, “BATT LOW” will be displayed. This message can be cleared by pressing CLR, FUN, MONTR, or just turning the power to the PC OFF and ON again.

Note The maximum life of the battery is 5 years, regardless of whether power is supplied to the CPU. The memory backup duration when power is not supplied to the CPU varies with the ambient temperature, and also depends on whether the Expansion DM Unit is mounted to the CPU (CV1000 only).

Details of the minimum lifetime of the battery are provided in *Appendix B Specifications*.

4-2 Memory Card Battery

The RAM Memory Card is provided with a backup memory battery.

When the Memory Card is mounted to the CPU and the battery life is close to expiring, the CPU ALARM indicator will blink, bit A42616 will turn ON, and the message "BATT LOW" will appear on the Programming Device. When this occurs, replace the battery within one week to avoid loss of data.

The entire replacement must be completed within one minute to ensure that the data will not be lost.

 **Caution** Do not short circuit, charge, disassemble, or expose the battery to heat. The battery fluid is flammable and if mishandled, may cause a fire or explosion. Do not incinerate the battery after use.

Battery Replacement

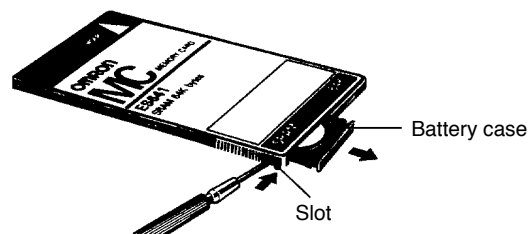

 **Caution** Steps 4 through 7 of the following procedure must be completed within 1 minute. If the new battery is not inserted within one minute, the contents of memory will be lost.

- 1, 2, 3...**
1. If the Memory Card (M/C) indicator is not lit, press the Memory Card power supply switch to turn on power to the Memory Card and leave it on for at least 10 seconds.
 2. Press the Memory Card power supply switch to turn off the Memory Card indicator.
 3. Press the Memory Card eject button and remove the Memory Card.
 4. Release the battery case by inserting the tip of a pen (or similar object) in the slot on the side of the Memory Card as shown.
 5. Remove the old battery from the case.
 6. Install the new battery as shown, with the positive terminal to the top.

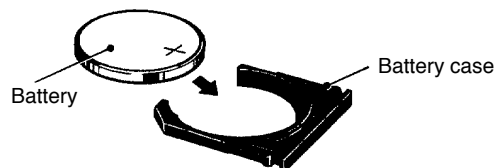

7. Insert the battery case back into the Memory Card. Be sure that the case is installed all the way in.

4-3 Output Unit Fuses

The following Output Units have one fuse each as shown in the table.

Output Unit	Fuse specifications
C500-OD411 C500-OD217 C500-OA223	250 V, 5 A
C500-OA121 C500-OA222 C500-OA226	250 V, 5 A
C500-OD219	250 V, 10 A

To replace a fuse in an Output Unit, perform the following steps.

- 1, 2, 3...**
1. Turn off the power to the PC.
 2. Detach the terminal block from the Output Unit by removing the screws located at the top and bottom of the terminal block.

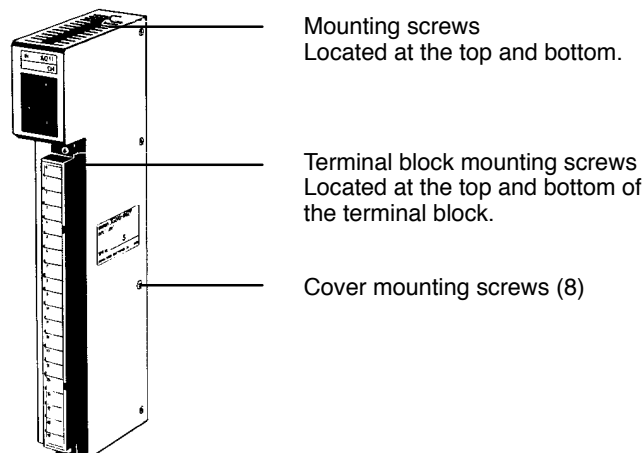

3. Remove the screws that mount the Output Unit to the Backplane. Pulling the Unit toward you, remove the Output Unit from the Backplane.
4. There are eight screws on each side of the Output Unit. Remove these screws to detach the case from the cover.
5. Pull out the printed circuit board.
6. Insert a new fuse.
7. Reassemble the Unit.

4-4 Output Unit Relays

To replace a Relay in an Output Unit, take the following steps.

- 1, 2, 3...**
1. Turn off the power to the PC.

2. Detach the terminal block from the Output Unit, by removing the screws located at the top and bottom of the terminal block.

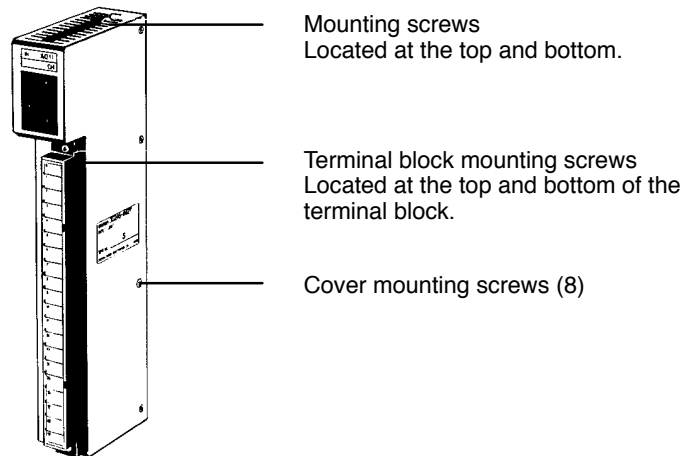

3. Remove the screws that mount the Output Unit to the Backplane. Pulling the Unit toward you, remove the Output Unit from the Backplane.
4. There are eight screws on each side of the Output Unit. Remove these screws to detach the case from the cover.
5. Pull out the printed circuit board.
6. Use the Relay Puller to pull out the Relay. Insert a new Relay.
7. Reassemble the Unit.

Note To remove the relay, use the P6B-Y1 Relay Puller. Be sure to insert the relay in the socket in the correct direction. The relay cannot be inserted in the wrong direction and if excessive force is applied to the relay, the pins of the relay may bend. The locations of relays on the PC boards are illustrated in the following figures.

3G2A5-OC221/223

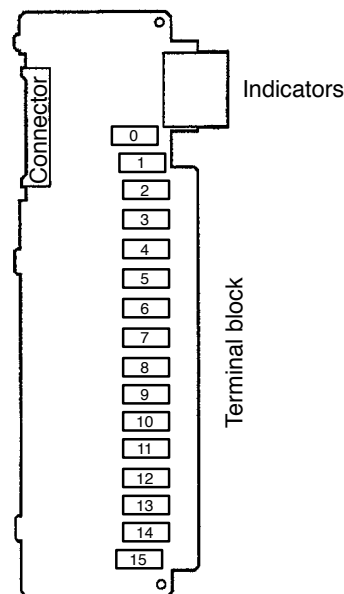

3G2A5-OC224

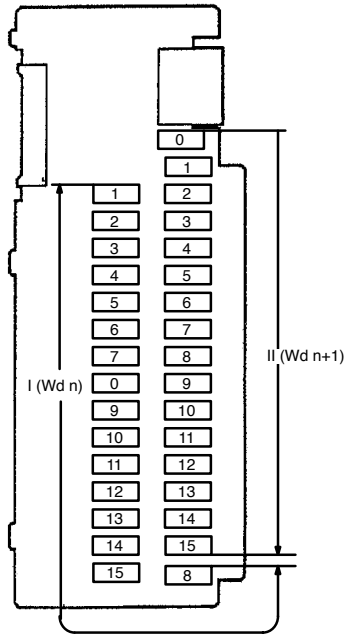

SECTION 5

Troubleshooting

This section describes the self-diagnosis functions of the PC and provides troubleshooting techniques and error corrections.

- 5-1 Error Messages and Alarm Outputs
- 5-2 Troubleshooting Flowcharts
- 5-3 Error Processing and Correction

5-1 Error Messages and Alarm Outputs

When an error occurs after operation has once started, an error code is set in Word A400. If two or more errors occur simultaneously, the error code having the highest priority is set. In the following table, the error having the highest priority is shown at the top of each column.

The status of indicators for which status is not show does not affect the error condition.

Startup Errors

Item	Cause	CPU indicators							Peripheral Device error message
		Power	RUN	ERROR	WDT	ALARM	OUT INT	COMM	
Start input wait	START input of CPU Rack Power Supply Unit is OFF.	Lit	Unlit	---	---	---	---	---	CPU WAITING
No SYSMAC BUS terminator	Terminator is not set.	Lit	Unlit	---	---	---	---	---	CPU WAITING
CPU Bus Unit initialization	Terminator of SYSMAC BUS/2 is missing, or CPU Bus Unit is still initializing.	Lit	Unlit	---	---	---	---	---	CPU WAITING
I/O verify error (PC Setup)	I/O Unit has been removed.	Lit	Unlit	---	---	Lit	---	---	CPU WAITING

Startup Errors (cont'd)

Item	RUN output	Auxiliary Area data		Corrective action
		Error flags	Error code	
Start input wait	OFF	A30600 ON	None	Turn ON the CPU Rack Power Supply Unit START input, or short-circuit the START input terminals.
No SYSMAC BUS terminator	OFF	A30602 ON	None	Turn on the power to the Remote I/O Slave Unit. Specify the Unit connected last as the terminator or wait until CPU Bus Units complete initialization.
CPU Bus Unit initialization	OFF	A30603 ON	None	Turn on the power to the Remote I/O Slave Unit. Specify the Unit connected last as the terminator.
I/O verify error (PC Setup)	OFF	A30601 ON A40209 ON	00E7	Verify the I/O table. Correct the table if necessary by create a new one.

Fatal Errors

Item	Cause	CPU indicators							Peripheral Device error message
		Power	RUN	ERROR	WDT	ALARM	OUT INT	COMM	
Power interruption	Power interruption occurred and lasted longer than the specified limit.	Unlit	Unlit	Unlit	Unlit	Unlit	Unlit	Unlit	POWER FAIL
Expansion CPU Rack power OFF	Expansion CPU Rack Power Supply Unit is OFF.	Lit	Unlit	Unlit	Unlit	Unlit	Unlit	Unlit	POWER FAIL
CPU error	Watchdog timer	Lit	Unlit	---	Lit	---	---	---	WDT ERR
Memory error	Error occurred during internal memory and Expansion DM verification.	Lit	Unlit	Lit	---	---	---	---	MEMORY ERR
I/O bus error	Erroneous data transferred between CPU and I/O Units	Lit	Unlit	Lit	---	---	---	---	I/O BUS ERR
Duplicated number	Rack numbers and CPU Bus Unit unit numbers or I/O words are assigned in duplicate.	Lit	Unlit	Lit	---	---	---	---	NO DUPL ERR
CPU bus error	Error in data transfer between CPU and CPU Bus Unit or watchdog timer error in CPU Bus Unit.	Lit	Unlit	Lit	---	---	---	---	CPU BUS ERR
I/O points over	Too many I/O points or too many Units are registered in the I/O table.	Lit	Unlit	Lit	---	---	---	---	I/O OVER
I/O setting error	Input/Output designation is wrong for I/O Unit.	Lit	Unlit	Lit	---	---	---	---	I/O SET ERR
Program error	END(001) is missing, or the capacity of the user memory is exceeded.	Lit	Unlit	Lit	---	---	---	---	NO END INSTR PROGRAM OVER
Cycle time over	Cycle time monitor time is exceeded.	Lit	Unlit	Lit	---	---	---	---	SCAN TIME OVER
Fatal SFC error	SFC syntax error.	Lit	Unlit	Lit	---	---	---	---	SFC ERR
System failure (FALS)	FALS was executed in program.	Lit	Unlit	Lit	---	---	---	---	SYSTEM FAL

Fatal Errors (cont'd)

Item	RUN output	Auxiliary Area data			Corrective action
		Error flags	Error data	Error code	
Power interruption	OFF	None	A012 to A013 (Power Interruption Time) A014 (Number of Power Interruptions)	None	Check the supply voltage, the Power Supply Unit wiring, and the defined power interruption time.
Expansion CPU Rack power OFF	OFF	None	None	None	Turn on the power to the Expansion CPU Rack.
CPU error	OFF	None	None	80FF	Turn the power OFF and ON again.
Memory error	OFF	A40115 ON	A403 (Memory Area Error Location)	80F1	Check/correct the program. Correctly mount the Memory Card and Expansion DM Unit. Check the battery connection. Perform the error clear operation after corrective actions have been taken.
I/O bus error	OFF	A40114 ON	AR404 (I/O Bus Error Rack and Slot Numbers)	80C0-80C7 (*) 80CE, 80CF	Check the cables between the Racks. Perform the error clear operation after corrective action has been taken.
Duplicated number	OFF	A40113 ON	A409 (Duplicate Rack Number) A410 (CPU Bus Unit Duplicate Number)	80E9	Set the Rack No. and Unit No. again. Then turn the power OFF and ON again. Perform the error clear operation after corrective action has been taken.
CPU bus error	OFF	A40112 ON	A405 (CPU Bus Unit Error Unit Number)	8100-8115 (**)	Check the cables between the CPU Rack and Expansion CPU Rack. Perform the error clear operation after corrective actions have been taken.
I/O points over	OFF	A40411 ON	A407 (Total I/O Words on CPU and Expansion Racks) A408 (Total SYSMAC BUS/2 I/O Words) A478 (Total SYSMAC BUS I/O Words)	80E1	Read the I/O table to check the number of words allocated. Correct the table if necessary by creating a new one.
I/O setting error	OFF	A40110 ON	None	80E0	Verify the I/O table. Correct the table if necessary.
Program error	OFF	A40109 ON	None	80F0	Correct the program. Perform the error clear operation after corrective actions have been taken.
Cycle time over	OFF	A40108 ON	A462/463 (Maximum Cycle Time) A464/465 (Present Cycle Time)	809F	Check the program or set time for monitoring the cycle.
Fatal SFC error	OFF	A40107 ON	A414 (SFC Fatal Error Code)	80F3	Correct the program. Perform the error clear operation after corrective actions have been taken.
System failure (FALS)	OFF	A40106 ON	None	C101 to C2FF (***)	Check/correct the program.

Note *0 through 7 indicate rack numbers; E indicates series 0; F indicates series 1.
 **00 through 15 indicate unit numbers.
 ***101 through 2FF indicate FALS numbers.

Non-fatal Errors

Item	Cause	CPU indicators							Peripheral Device error message
		Power	RUN	ERROR	WDT	ALARM	OUT INT	COMM	
System error (FAL)	Program has executed FAL	Lit	Lit	Unlit	Unlit	Lit	---	---	SYSTEM ERR FAL
JMP error	Destination of JMP/CJP/CJPN is missing.	Lit	Lit	Unlit	Unlit	Lit	---	---	JMP ERR
Indirect DM BCD error	Data for indirectly addressed DM is not BCD.	Lit	Lit	Unlit	Unlit	Lit	---	---	INDIRECT DM BCD ERR
Non-fatal SFC error	Error has occurred during SFC execution.	Lit	Lit	Unlit	Unlit	Lit	---	---	SFC CONTINUE ERR
I/O verification error	I/O table contains a different number of I/O points than is actually mounted.	Lit	Lit	Unlit	Unlit	Lit	---	---	I/O VERIFY ERR
CPU Bus Unit error	Parity error occurs during data transfer between CPU and CPU Bus Unit.	Lit	Lit	Unlit	Unlit	Lit	---	---	CPU SPECIAL UNIT ERR
SYSMAC BUS/2 error	Error occurs between Master and Slave in SYSMAC BUS/2.	Lit	Lit	Unlit	Unlit	Lit	---	---	SYSMAC BUS/2 ERR
SYSMAC BUS error	Error occurs between Master and Slave in SYSMAC BUS.	Lit	Lit	Unlit	Unlit	Lit	---	---	SYSMAC BUS ERR
Battery failure	Battery of CPU or Memory Card is not connected or battery voltage is low.	Lit	Lit	Unlit	Unlit	Lit	---	---	BATTERY ERR
CPU Bus Unit setting error	Number assigned to CPU Bus Unit does not agree with registered unit number.	Lit	Lit	Unlit	Unlit	Lit	---	---	CPU SPECIAL UNIT SETTING ERR
Momentary power interruption	Momentary power interruption occurred (when specified as error by in PC Setup)	Lit	Lit	Unlit	Unlit	Lit	---	---	PROTECTED
Output inhibit (*)	Bit A00015 is ON.	Lit	Lit	Unlit	Unlit	---	Lit	---	---
Host link communication	Error has occurred during host link communication	Lit	Lit	Unlit	Unlit	---	---	Lit	---

Note *All outputs of the I/O Units are turned OFF.

Non-fatal Errors (cont'd)

Item	RUN output	Auxiliary Area data			Corrective action
		Error flags	Error data	Error code	
System error (FAL)	ON	A40215 ON	A430 to A461 (Executed FAL Number)	4101-42FF (*)	Check the program.
JMP error	ON	A40213 ON	None	00F9	Check and correct the program.
Indirect DM BCD error	ON	A40212 ON	None	00F8	
Non-fatal SFC error	ON	A40211 ON	A418 (SFC Non-fatal Error Code)	00F4	
I/O verification error	ON	A40209 ON	None	00E7	Verify the I/O table. After the corrective actions have been taken, create a new I/O table.
CPU Bus Unit error	ON	A40207 ON	A422 (CPU Bus Unit Error Unit Number) A42315 ON (CPU Bus Link Error Flag)	0020-0215 0231 (**)	Check the Unit.
SYSMAC BUS/2 error	ON	A40206 ON	A424 (SYSMAC BUS/2 Error Master Number) A480 to A499 (SYSMAC BUS/2 Error Unit Number)	00B0-00B3 (***)	Check transmission lines for SYSMAC BUS/2. Check to see if SYSMAC BUS/2 Slave is normal.
SYSMAC BUS error	ON	A40205 ON	A425 (SYSMAC BUS Error Master Number) A470 to A477 (SYSMAC BUS Error Codes)	00A0-00A7 (****)	Check transmission lines for SYSMAC BUS. Check to see if SYSMAC BUS Slave is normal.
Battery failure	ON	A40204 ON	A42615 (PC Battery Low Flag) A42614 (Memory Card Battery Low Flag)	00F7	Replace the battery of the CPU or Memory Card. Check the connections of the CPU battery.
CPU Bus Unit setting error	ON	A40203 ON	A427 (CPU Bus Unit Parameter Error Unit Number)	0400-0415	Check the Unit.
Momentary power interruption	ON	A40202 ON	A012 to A013 (Power Interruption Time) A014 (Number of Power Interruptions)	0002	Check the supply voltage and Power Supply Unit wiring.
Output inhibit	ON	A00015 ON	None	---	Turn OFF A00015.
Host link communication	ON	---	None	---	Release memory protection.

Note * 101 through 2FF indicate FAL Nos.

** 00 through 15 indicate the Unit Nos. of the CPU Bus Units. 31 indicates a CPU bus link error.

*** 0 through 3 indicate the RM addresses of SYSMAC BUS/2.

**** 0 through 7 indicate the RM addresses of SYSMAC BUS.

***** G: CPU Bus Link Area.

5-2 Troubleshooting Flowcharts

Main Flowchart

When an unknown error arises, the following troubleshooting flowchart can be used to help locate the problem.

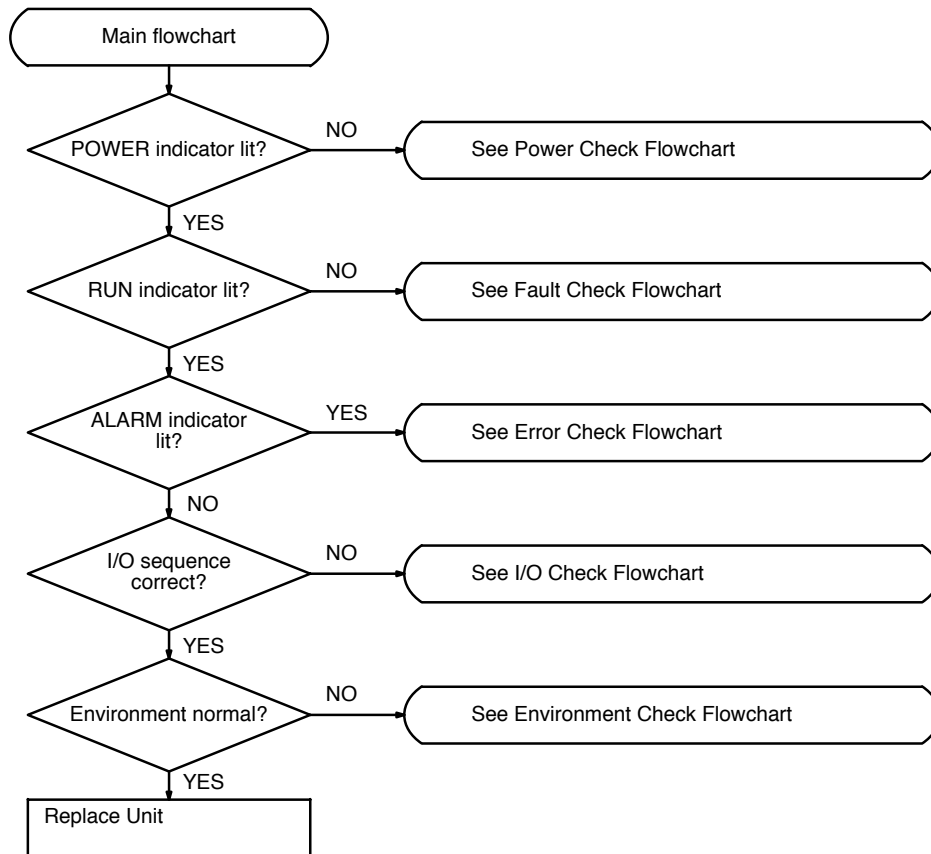

- Note**
1. Before replacing a Unit, be sure to turn off the power to the PC. The same applies to when replacing the Expansion Data Memory Unit, batteries, wiring, and cables.
 2. When replacing the CPU, start operation only after transferring the contents of the data memory or holding bits that are required for resuming operation to the replaced CPU.

Power Check Flowchart

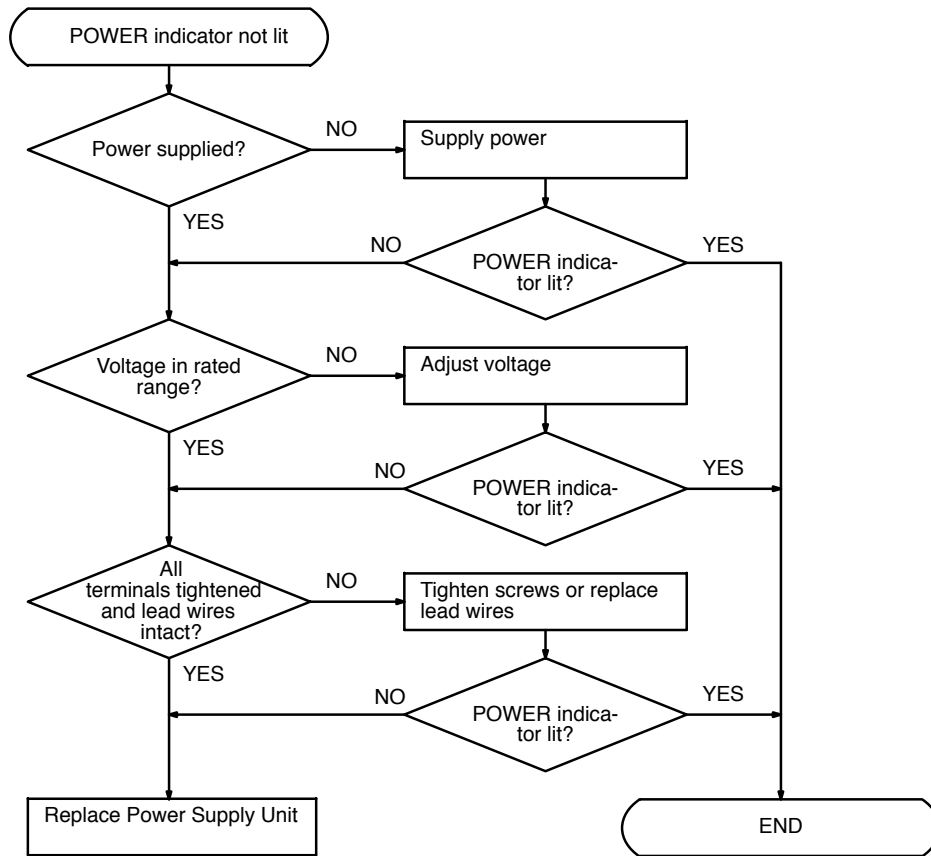

Unit	Supply voltage	Operating voltage range
CV500-PS221	100 to 120 VAC	85 to 132 VAC
CVM1-PA208	200 to 240 VAC	170 to 264 VAC
CV500-PS211	24 VDC	20.4 to 28.8 VDC

- Note**
1. The fuse inside the DC Power Supply Unit will burn out if power is turned on with the 5-V output terminals shorted.
 2. If the POWER indicator does not light when power is properly supplied, replace the Power Supply Unit.

Fault Check Flowchart

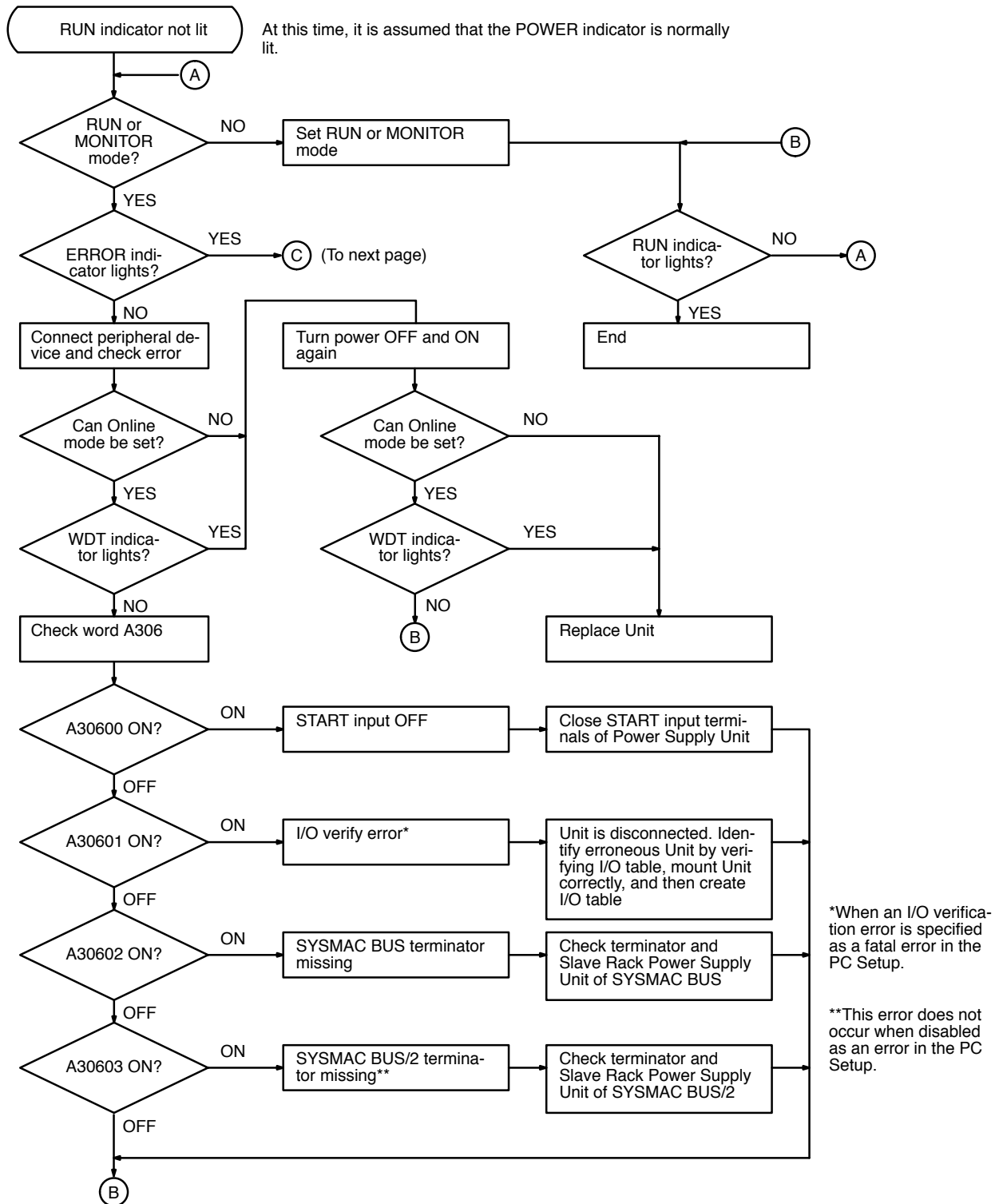

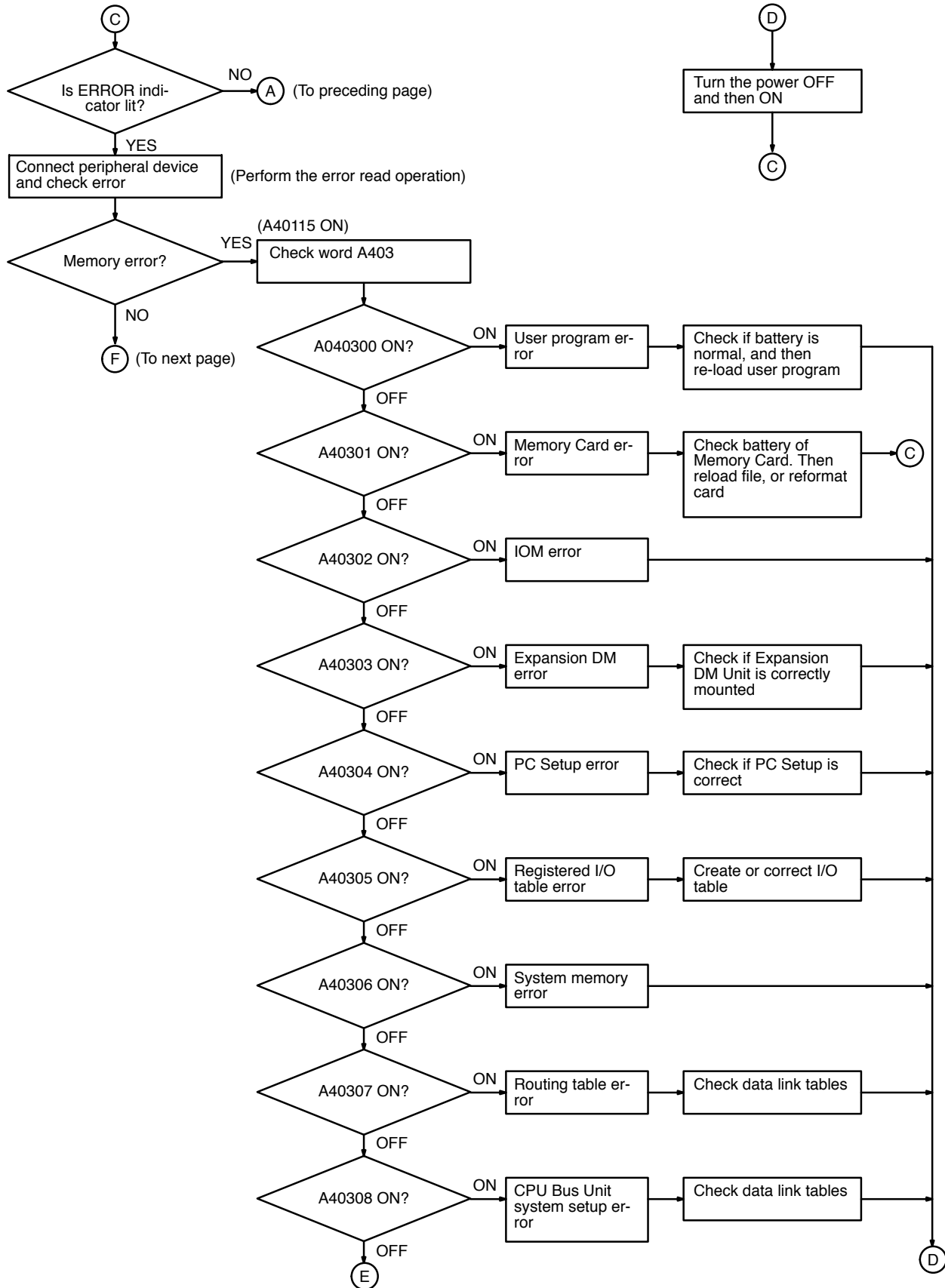

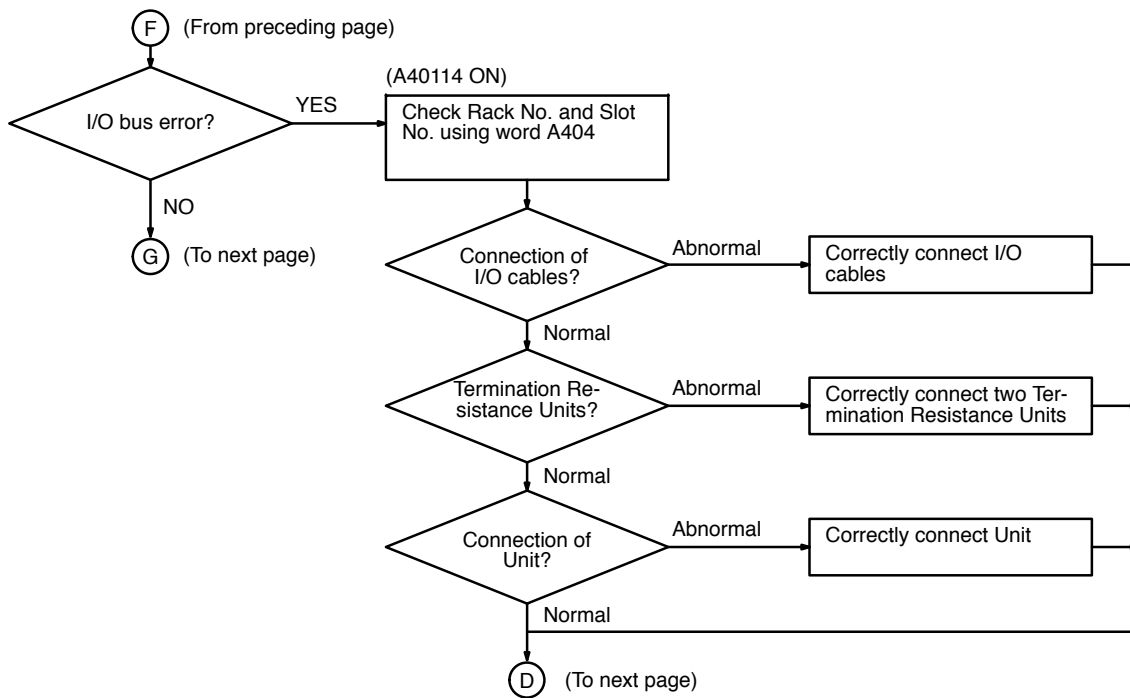
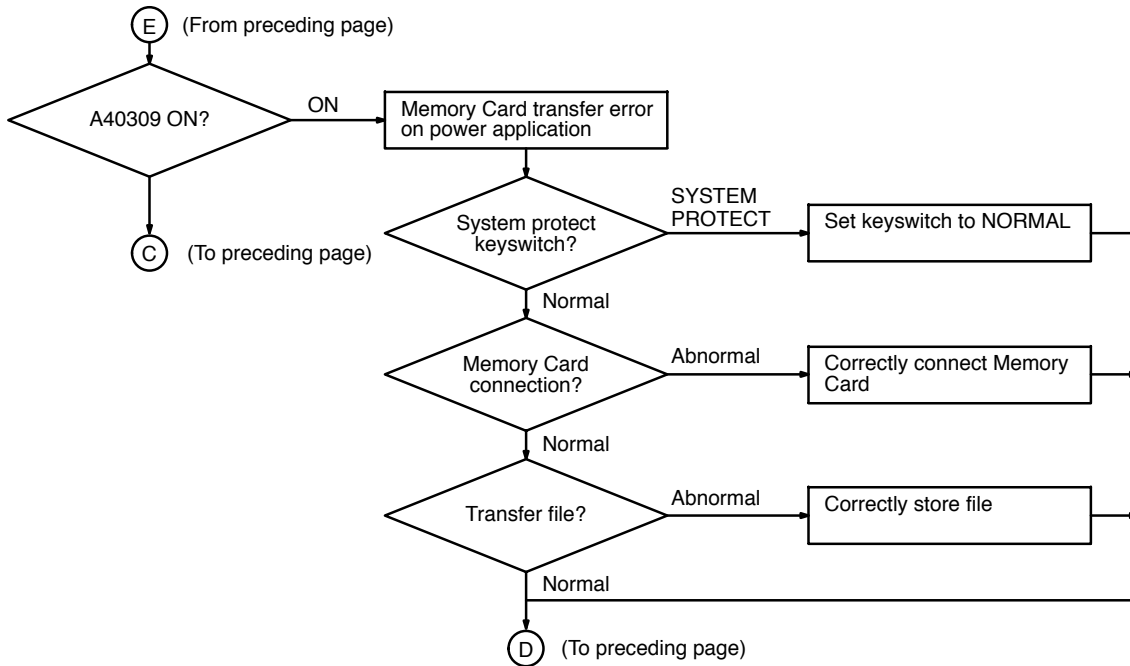

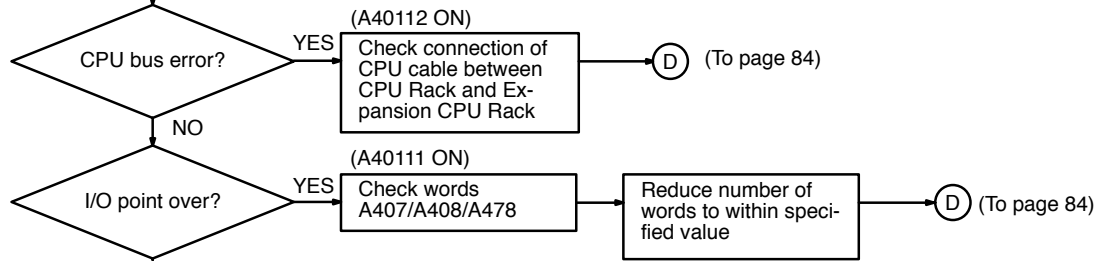
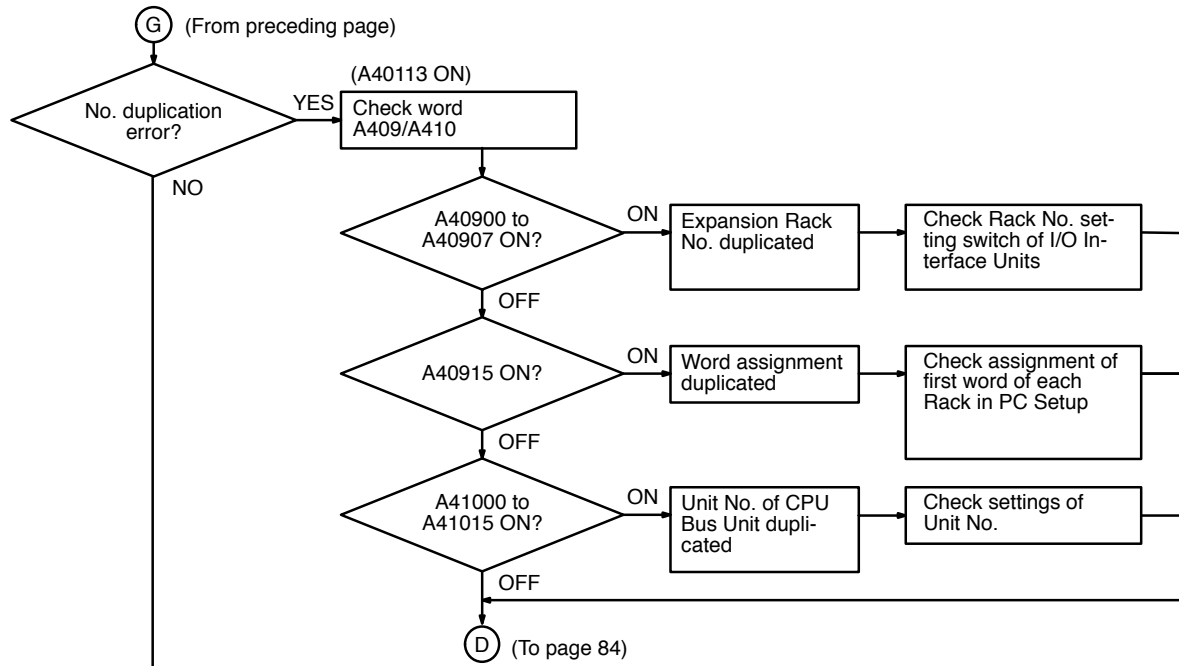

	Word A407	Word A408	Word A478
	No. of basic rack words	No. of SYSMAC BUS/2 words	No. of SYSMAC BUS words
CV500/CVM1-CPU01-EV2	32	64	32
CV1000/CVM1-CPU11-EV2	64	128	64
CV2000	128	128	64
CVM1-CPU21-EV2128	128	128	

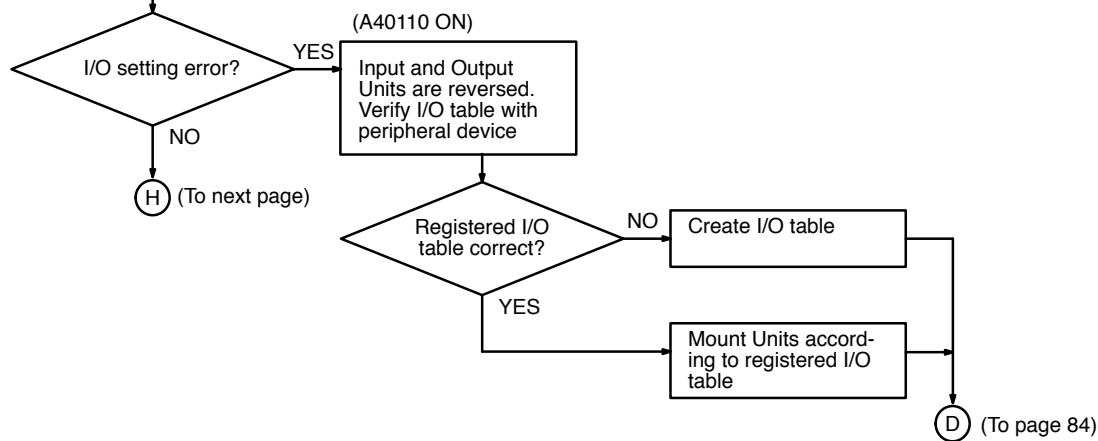

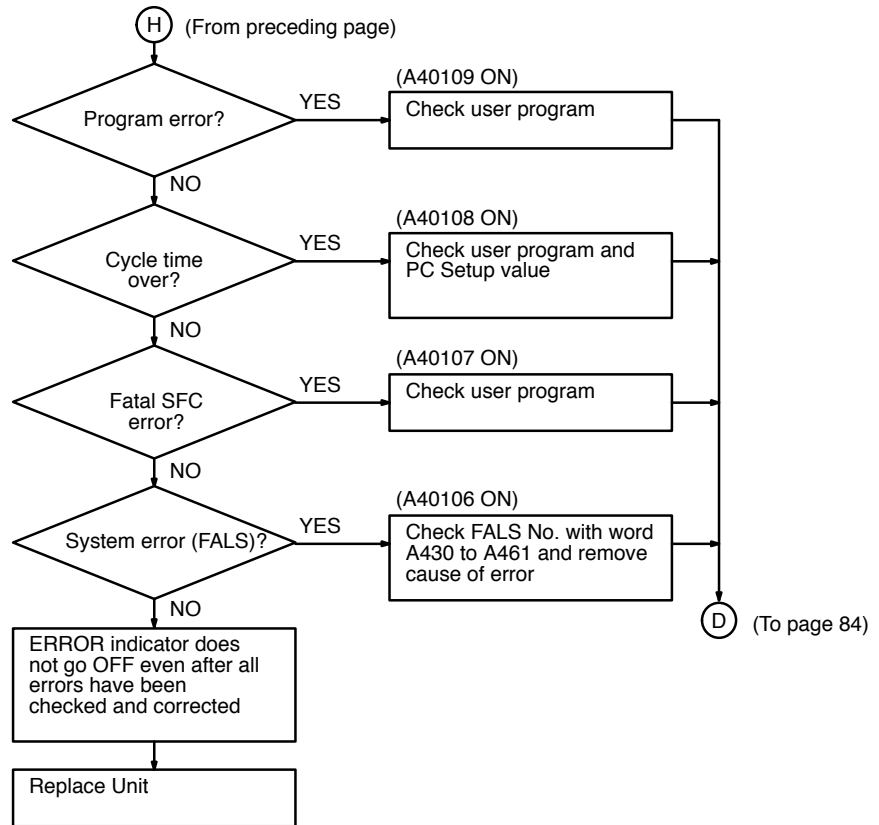

Alarm Check Flowchart

Although the PC does not stop when the ALARM indicator lights, check and correct such errors as soon as possible.

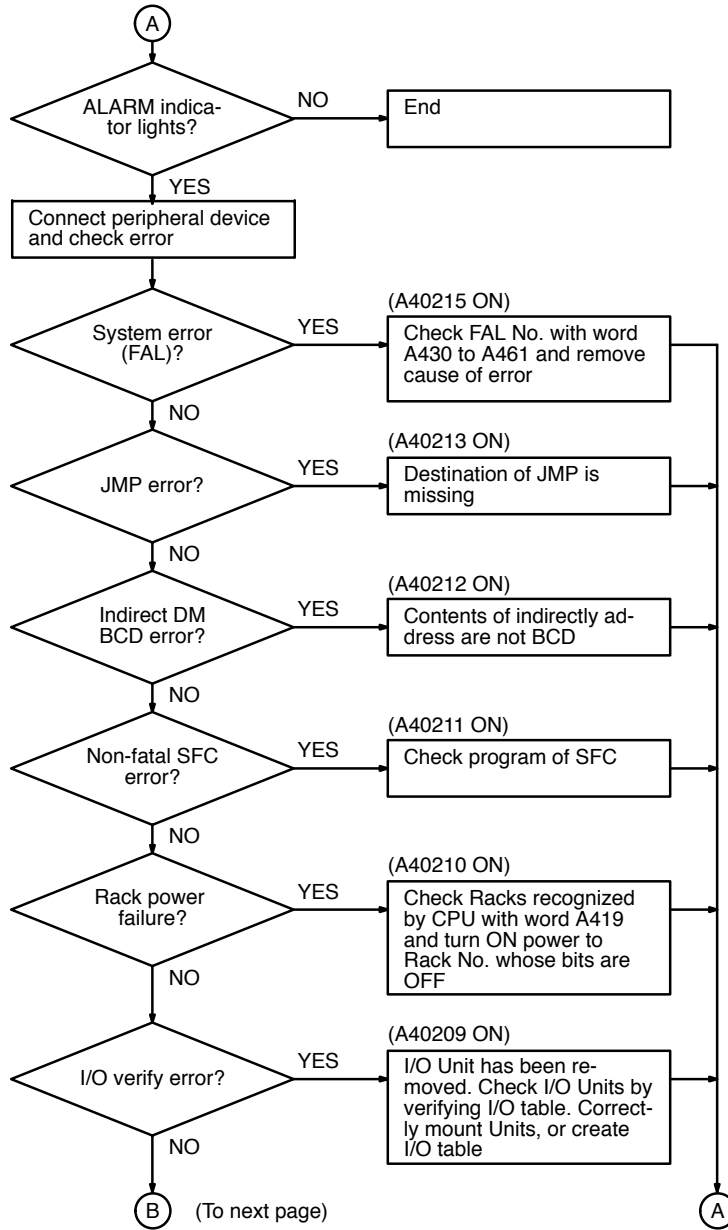

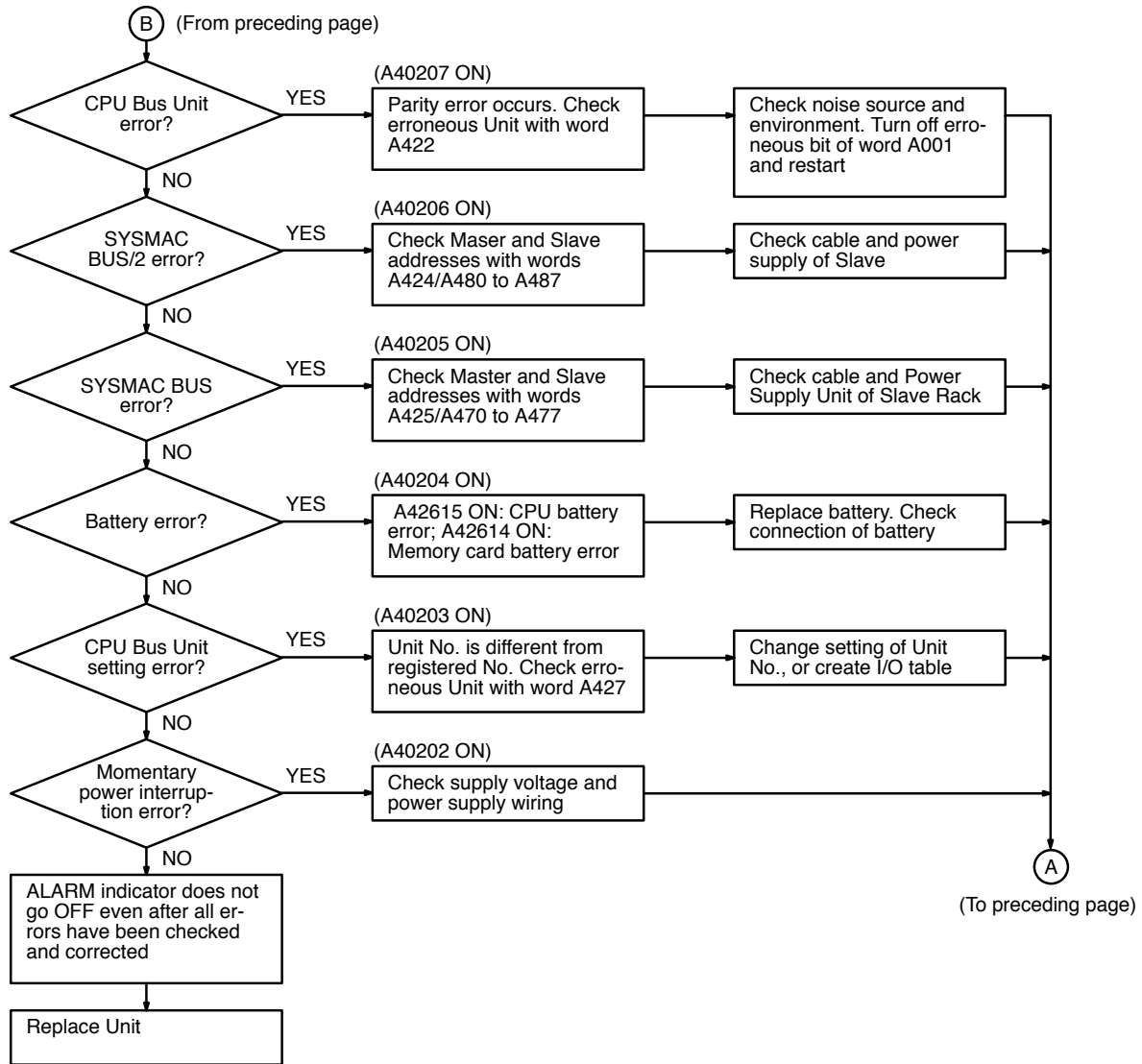

I/O Check Flowchart

It is assumed that the ladder diagram shown below is programmed and that SOL1 malfunctions.

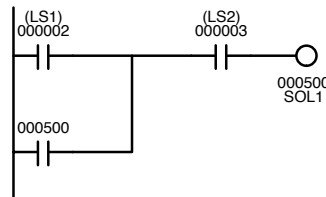

Given such a malfunction, the flowchart on the following page may be used to help locate the problem.

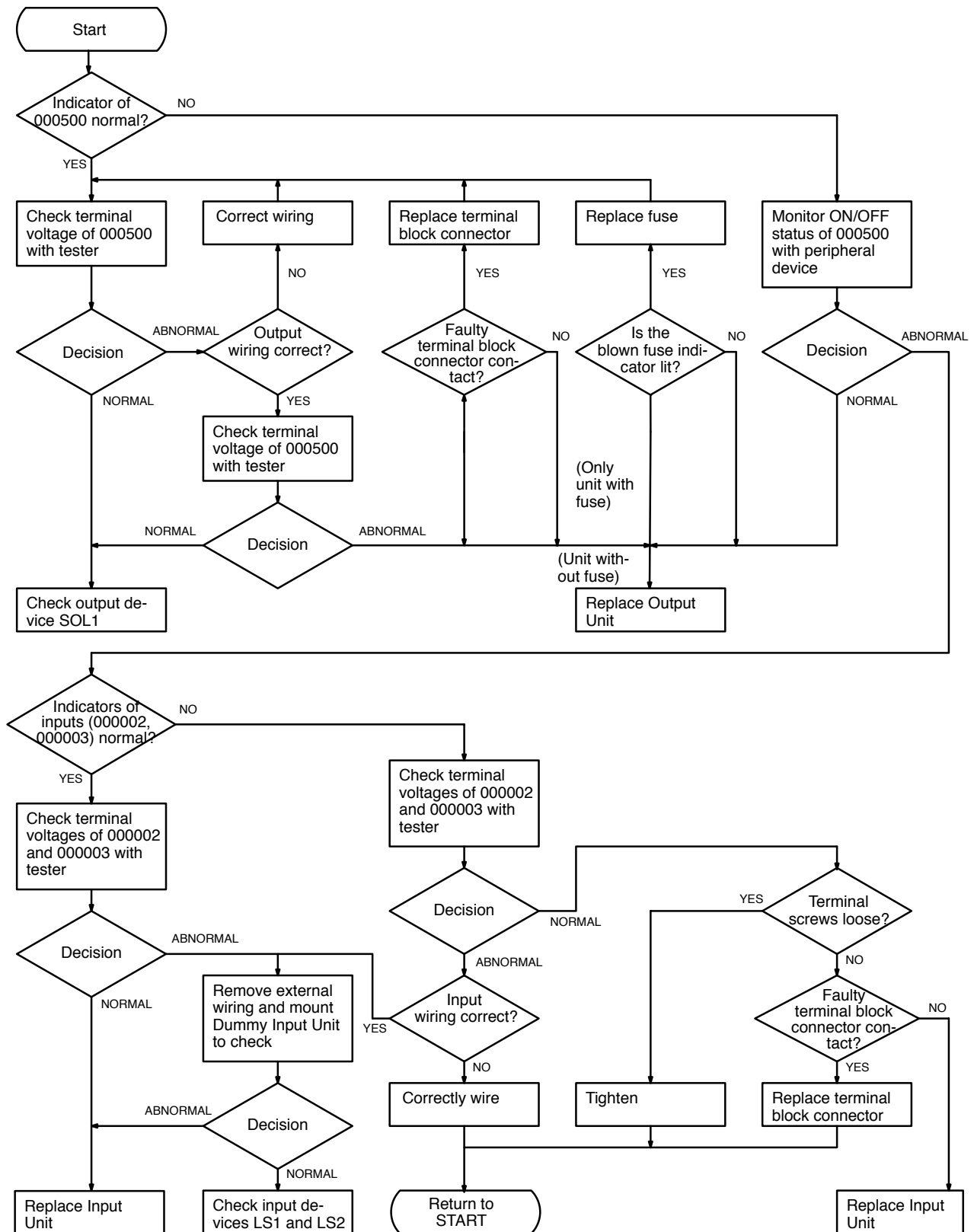

Environment Check Flowchart

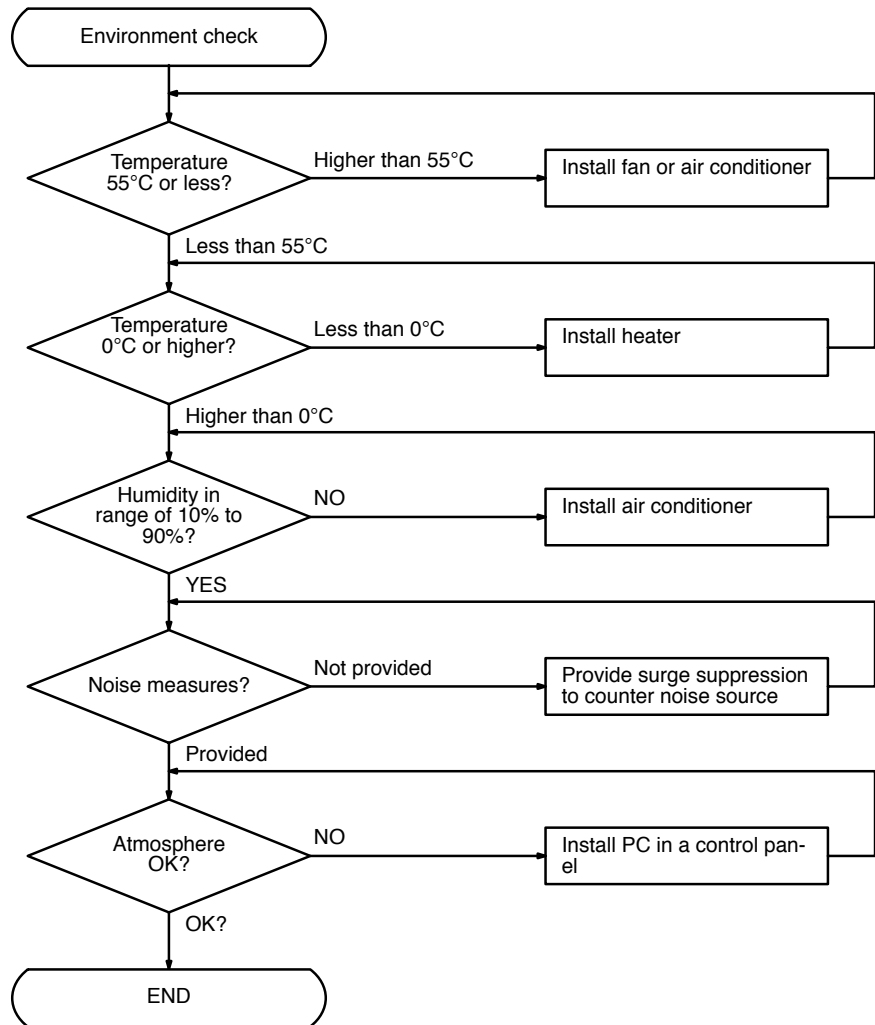

5-3 Error Processing and Correction

CPU Rack/Expansion CPU Rack/Expansion I/O Rack

Symptom	Cause	Remedy
POWER indicator is unlit.	PCB short-circuited or damaged by heat.	Replace Power Supply Unit or Backplane.
RUN indicator is unlit.	(1) START input terminals are OFF.	Short-circuit START input terminals.
	(2) Error in program.	Correct program
	(3) Power line is faulty.	Replace Power Supply Unit.
RUN output does not turn ON. RUN indicator lit.	Internal circuitry of Power Supply Unit is faulty.	Replace Power Supply Unit.
Link Unit or CPU Bus Unit does not operate or malfunctions.	(1) CPU cable is faulty.	Replace CPU cable.
	(2) CPU bus is faulty.	Replace Backplane.
	(3) Expansion CPU Rack is faulty.	Replace I/O Control or I/O Interface Unit.
Bit does not operate.	I/O bus faulty.	Replace Backplane.
Error occurs in units of 8 points.	(1) I/O cable is faulty.	Replace I/O cable.
	(2) I/O bus is faulty.	Replace Backplane.
	(3) Expansion I/O Rack is faulty.	Replace I/O Control or I/O Interface Unit.
I/O bit turns ON	I/O bus is faulty.	Replace Backplane.
All bits for one Unit do not turn ON.	I/O bus is faulty.	Replace Backplane.

Input Units

Symptom	Cause	Remedy
Not all inputs turn ON or indicators are not lit.	(1) Power is not supplied to Input Unit.	Supply power
	(2) Supply voltage is low.	Adjust supply voltage to within rated range.
	(3) Terminal block mounting screws are loose.	Tighten screws.
	(4) Faulty contact of terminal block connector.	Replace terminal block connector.
Not all inputs turn ON (indicator lit).	Input circuit is faulty.	Replace Unit.
Not all inputs turn OFF.	Input circuit is faulty.	Replace Unit.
Specific bit does not turn ON.	(1) Input device is faulty.	Replace input devices.
	(2) Input wiring disconnected.	Check input wiring
	(3) Terminal block screws are loose.	Tighten screws
	(4) Faulty terminal block connector contact.	Replace terminal block connector.
	(5) Too short ON time of external input.	Adjust input device
	(6) Faulty input circuit	Replace Unit.
	(7) Input bit number is used for output instruction.	Correct program.
Specific bit does not turn OFF.	(1) Input circuit is faulty.	Replace Unit.
	(2) Input bit number is used for output instruction.	Correct program.
Input irregularly turns ON/OFF.	(1) External input voltage is low.	Adjust external input voltage to within rated range.
	(2) Malfunction due to noise.	Protective measures against noise, such as: (1) Install surge suppressor. (2) Install insulation transformer. (3) Install shielded cable.
	(3) Terminal block screws are loose.	Tighten screws
	(4) Faulty terminal block connector contact.	Replace terminal block connector.
Error occurs in units of 8 points.	(1) Common terminal screws are loose.	Tighten screws
	(2) Faulty terminal block connector contact.	Replace terminal block connector.
	(3) Faulty data bus	Replace Unit.
	(4) Faulty CPU	Replace CPU.
Input indicator is not lit in normal operation.	Faulty indicator	Replace Unit.

Output Units

Symptom	Cause	Remedy
Not all outputs turn ON	(1) Load is not supplied with power.	Supply power
	(2) Load voltage is low.	Adjust voltage to within rated range.
	(3) Terminal block screws are loose.	Tighten screws
	(4) Faulty terminal block connector contact.	Replace terminal block connector.
	(5) Blown fuse	Replace fuse.
	(6) Faulty I/O bus connector contact.	Replace Unit.
	(7) Output circuit is faulty.	Replace Unit.
Not all outputs turn OFF	Output circuit is faulty.	Replace Unit.
Output of a specific bit number does not turn ON or indicator is not lit	(1) Output ON time too short.	Correct program.
	(2) Bit status controlled by multiple instructions.	Correct program.
	(3) Faulty output circuit.	Replace Unit.
Output of a specific bit number does not turn ON (indicator lit).	(1) Faulty output device.	Replace output device.
	(2) Break in output wiring.	Check output wiring.
	(3) Loose terminal block screws.	Tighten screws.
	(4) Faulty terminal block connector faulty.	Replace terminal block connector.
	(5) Faulty output bit.	Replace relay.
	(6) Faulty output circuit.	Replace Unit.
Output of a specific bit number does not turn OFF (indicator unlit).	(1) Faulty output bit.	Replace relay.
	(2) Bit does not turn OFF due to leakage current or residual voltage.	Replace external load or add dummy resistor.
Output of a specific bit number does not turn OFF (indicator lit).	(1) Bit status controlled by multiple instructions.	Correct program.
	(2) Faulty output circuit.	Replace Unit.
Output irregularly turns ON/OFF.	(1) Low load voltage.	Adjust load voltage to within rated range
	(2) Bit status controlled by multiple instructions.	Correct program
	(3) Malfunction due to noise.	Protective measures against noise: (1) Install surge suppressor. (2) Install insulation transformer. (3) Use shielded cable.
	(4) Terminal block screws are loose.	Tighten screws.
	(5) Faulty terminal block connector contact.	Replace terminal block connector.
Error occurs in units of 8 points.	(1) Loose common terminal screw.	Tighten screws.
	(2) Faulty terminal block connector contact.	Replace terminal block connector.
	(3) Blown fuse.	Replace fuse.
	(4) Faulty data bus.	Replace Unit.
	(5) Faulty CPU.	Replace CPU.
Output indicator is not lit (operation is normal).	Faulty indicator.	Replace Unit.

Appendix A

Standard Models

CPU Racks

Name	Specifications		Model
CPU Backplane	10 slots		CV500-BC101
	5 slots		CV500-BC051
	3 slots		CV500-BC031
	10 slots (CPU Bus Unit: rightmost 6 slots only)	Does not support I/O Control Unit or more than one Expansion I/O Rack.	CVM1-BC103
	5 slots (CPU Bus Unit: rightmost 3 slots only)		CVM1-BC053
CPU	CV500: Ladder only or SFC + Ladder	Basic I/O: 512 pts	CV500-CPU01-EV1
	CV1000: Ladder only or SFC + Ladder	Basic I/O: 1,024 pts	CV1000-CPU01-EV1
	CV2000: Ladder only or SFC + Ladder	Basic I/O: 2,048 pts	CV2000-CPU01-EV1
	CVM1: Ladder only	Basic I/O: 512 pts	CVM1-CPU01-EV2
		Basic I/O: 1,024 pts	CVM1-CPU11-EV2
		Basic I/O: 2,048 pts	CVM1-CPU21-EV2
	Power Supply Unit	100 to 120/200 to 240 VAC Output: 12 A, 5 VDC	CV500-PS221
100 to 120/200 to 240 VAC Output: 8 A, 5 VDC		CVM1-PA208	
24 VDC Output: 12 A, 5 VDC		CV500-PS211	
I/O Control Unit	To connect Expansion CPU and Expansion I/O Racks*		CV500-IC101
	To connect Expansion I/O Racks*		CV500-IC201
	To connect C500 Expansion I/O Racks		CV500-IC301
Memory Card	RAM	64K bytes	HMC-ES641
		128K bytes	HMC-ES151
		256K bytes	HMC-ES251
		512K bytes	HMC-ES551
	EEPROM	64K bytes	HMC-EE641
		128K bytes	HMC-EE151
	EPROM (Requires CV500-MCW01)	512 bytes	HMC-EP551
		1M bytes	HMC-EP161
Expansion Data Memory Unit	For CV1000, CV2000, or CVM1-CPU21-EV2 only	64K bytes	CV1000-DM641
		128K bytes	CV1000-DM151
		256K bytes	CV1000-DM251

Note *Two CV500-TER01 Terminal Resistance Units are provided with each CV500-IC101/201 I/O Control Unit.

Expansion CPU Racks

Name	Specifications	Model
Expansion CPU Backplane	11 slots	CV500-BI111
Power Supply Unit	100 to 120/200 to 240 VAC Output: 12 A, 5 VDC	CV500-PS221
	100 to 120/200 to 240 VAC Output: 8 A, 5 VDC	CVM1-PA208
	24 VDC Output: 12 A, 5 VDC	CV500-PS211
I/O Interface Unit	For Expansion CPU Rack	CV500-II101
CPU Bus Cable	Length: 30 cm	CV500-CN311
	Length: 60 cm	CV500-CN611
I/O Cable	Length: 30 cm	CV500-CN312
	Length: 60 cm	CV500-CN612
Termination Resistance Unit	Mount to an I/O Expansion Unit to be used as a terminator. Two Termination Resistance Units are provided the CV500-IC101/201 I/O Control Unit.	CV500-TER01

Expansion I/O Backplanes

Name	Specifications	Model
Expansion I/O Backplane	11 slots	CV500-BI112
	6 slots	CV500-BI062
	4 slots	CV500-BI042
	11 slots (Must be connected directly to CPU Backplane.)	CVM1-BI114
	6 slots (Must be connected directly to CPU Backplane.)	CVM1-BI064
Power Supply Unit	100 to 120/200 to 240 VAC Output: 12 A, 5 VDC	CV500-PS221
	100 to 120/200 to 240 VAC Output: 8 A, 5 VDC	CVM1-PA208
	24 VDC Output: 12 A, 5 VDC	CV500-PS211
I/O Interface Unit	For Expansion I/O Rack	CV500-II201
I/O Cable	30 cm	CV500-CN312
	60 cm	CV500-CN612
	1 m	CV500-CN122
	2 m	CV500-CN222
	10 m	CV500-CN132
	30 m	CV500-CN332
	50 m	CV500-CN532
I/O Cable for 1 Exp. I/O Rack	40 cm	CV500-CN413
	60 cm	CV500-CN613
Termination Resistance Unit	Mount to an I/O Expansion Unit to be used as a terminator. Two Termination Resistance Units are provided the CV500-IC101/201 I/O Control Unit.	CV500-TER01

Input Units

Name		Specifications			Model
Input Units	DC	16 mA, 5 to 12 VDC; ON delay: 1.5 ms, OFF delay: 1.5 ms	16 pts	8 pts/common; 2 circuits	3G2A5-ID112
		10 mA, 12 to 24 VDC; ON delay: 1.5 ms, OFF delay: 1.5 ms	16 pts	8 pts/common; 2 circuits	3G2A5-ID213
		10 mA, 12 to 24 VDC; ON delay: 1.5 ms, OFF delay: 1.5 ms	32 pts	8 pts/common; 4 circuits	3G2A5-ID215
		10 mA, 12 to 24 VDC; ON delay: 1.5 ms, OFF delay: 1.5 ms	32 pts	8 pts/common; 4 circuits	3G2A5-ID218
		10 mA, 12 to 24 VDC; connector type	32 pts	8 pts/common; 4 circuits	C500-ID218CN
		7 mA, 12 VDC; static; ON delay: 1.5 ms, OFF delay: 1.5 ms	64 pts	8 pts/common; 8 circuits	C500-ID114
		10 mA, 24 VDC; dynamic scan	64 pts	---	3G2A5-ID212
		7 mA, 24 VDC; ON delay: 1.5 ms, OFF delay: 1.5 ms	64 pts	8 pts/common; 8 circuits	3G2A5-ID219
	Interrupt	10 mA, 12 to 24 VAC; ON delay: 1 ms, OFF delay: 1.5 ms (Not mountable to Duplex C2000H Rack)	8 pts	Independent commons	3G2A5-ID216
	AC	10 mA, 100 to 120 VAC; ON delay: 35 ms, OFF delay: 55 ms	16 pts	8 pts/common; 2 circuits	3G2A5-IA121
		10 mA, 200 to 240 VAC; ON delay: 35 ms, OFF delay: 55 ms	16 pts	8 pts/common; 2 circuits	3G2A5-IA222
		10 mA, 100 to 120 VAC; ON delay: 35 ms, OFF delay: 55 ms	32 pts	8 pts/common; 4 circuits	3G2A5-IA122
		10 mA, 200 to 240 VAC; ON delay: 35 ms, OFF delay: 55 ms	32 pts	8 pts/common; 4 circuits	C500-IA223
	AC/DC	10 mA, 12 to 24 VAC/DC; ON delay: 15 ms, OFF delay: 15 ms	16 pts	8 pts/common; 2 circuits	3G2A5-IM211
		10 mA, 12 to 24 VAC/DC; ON delay: 15 ms, OFF delay: 15 ms	32 pts	8 pts/common; 4 circuits	3G2A5-IM212
	TTL	3.5 mA, 5 VDC; connector	32 pts	8 pts/common; 4 circuits	C500-ID501CN

Output Units

Name		Specifications			Model
Output Units	Contact	2 A, 250 VAC/24 VDC; with relay sockets; 8 commons	16 pts	8 pts/common; 2 circuits	3G2A5-OC221
		2 A, 250 VAC/24 VDC; with relay sockets; all outputs independent	16 pts	Independent commons	3G2A5-OC223
		2 A, 250 VAC/24 VDC; with relay sockets	32 pts	8 pts/common; 4 circuits	3G2A5-OC224
	Transistor	1 A, 12 to 24 VDC; no output when external power supply is OFF	16 pts	8 pts/common; 2 circuits	C500-OD217
		2.1 A, 12 to 24 VDC	16 pts	8 pts/common; 2 circuits	C500-OD219
		1 A, 12 to 48 VDC	16 pts	16 pts/common; 1 circuit	3G2A5-OD411
		50 mA, 24 VDC; all outputs independent	16 pts	Independent commons	3G2A5-OD215
		0.3 A, 12 to 24 VDC	32 pts	16 pts/common; 2 circuits	C500-OD218
		0.3 A, 12 to 48 VDC	32 pts	16 pts/common; 2 circuits	C500-OD414
		0.3 A, 12 to 48 VDC; negative common; terminal block	32 pts	32 pts/common; 1 circuit	3G2A5-OD412
		0.3 A, 12 to 24 VDC; positive common	32 pts	16 pts/common; 2 circuits	3G2A5-OD212
		0.3 A, 12 to 48 VDC; negative common; connector	32 pts	16 pts/common; 2 circuits	C500-OD415CN
		0.1 A, 24 VDC; dynamic scan	64 pts	---	3G2A5-OD211
		0.1 A, 24 VDC; static connector	64 pts	8 pts/common; 8 circuits	3G2A5-OD213
	Triac	1 A, 100 to 120 VAC; with built-in surge killer	16 pts	8 pts/common; 2 circuits	3G2A5-OA121
		1 A, 100 to 240 VAC; with built-in surge killer	16 pts	8 pts/common; 2 circuits	3G2A5-OA222
		1 A, 100 to 240 VAC	24 pts	8 pts/common; 3 circuits	3G2A5-OA223
		1 A, 100 to 240 VAC	32 pts	8 pts/common; 4 circuits	C500-OA225
		1.2 A, 100 to 240 VAC	16 pts	8 pts/common; 2 circuits	C500-OA226
TTL	35 mA, 5 VDC; connector	32 pts	8 pts/common; 4 circuits	C500-OD501CN	
DC Input/Transistor Output Unit	12 to 24-VDC inputs: 10 mA; 12 to 24-VDC outputs: 0.3 connector	16 pts each	---	C500-MD211CN	
Dummy I/O Unit	Input or output	16, 32, or 64 points	---	3G2A5-DUM01	
I/O Power Supply Unit	Input: 100 to 120/200 to 240 VAC Output: 2A, 24 VDC		---	CV500-IPS01	

Special I/O Units

Name	Specifications		Model
Analog Input Unit	4 to 20 mA, 1 to 5 V; 2 inputs	2 pts	3G2A5-AD001
	0 to 10 V; 2 inputs	2 pts	3G2A5-AD002
	0 to 5 V; 2 inputs	2 pts	3G2A5-AD003
	-10 to 10 V; 2 inputs	2 pts	3G2A5-AD004
	-5 to 5 V; 2 inputs	2 pts	3G2A5-AD005
	4 to 20 mA, 1 to 5 V; 4 inputs	4 pts	3G2A5-AD006
	0 to 10 V; 4 inputs	4 pts	3G2A5-AD007
	0 to 10 V, 0 to 20 mA (selectable); 8 inputs	8 pts	C500-AD101
	0 to 5 V, 0 to 10 V -5 to 5 V, -10 to 10 V, 0 to 20 mA, -20 to 20 mA; 16 inputs	16 pts	C500-AD501
Analog Output Unit	4 to 20 mA, 1 to 5 V; 2 outputs	2 pts	3G2A5-DA001
	0 to 10 V; 2 outputs	2 pts	3G2A5-DA002
	0 to 5 V; 2 outputs	2 pts	3G2A5-DA003
	-10 to 10 V; 2 outputs	2 pts	3G2A5-DA004
	-5 to 5 V; 2 outputs	2 pts	3G2A5-DA005
	0 to 20 mA, 1 to 5 V/0 to 10 V (selectable); 4 outputs	4 pts	C500-DA101
	-10 to 10 V, 4 outputs	4 pts	C500-DA103
High-speed Counter Unit	6-digit BCD; 50 kcps; one counted input; 1 pair of SV	1 pt	3G2A5-CT001
	6-digit BCD; 50 kcps; one counted input; 8 pair of SV	1 pt	3G2A5-CT012
	50 kcps; 7 operating modes	2 pts	C500-CT021
	6-digit BCD; 20 kcps; four counted inputs; 6 modes	4 pts	C500-CT041
Magnetic Card Reader Unit	With RS-232C interface		3G2A5-MGC01
PID Control Unit	For PID control; w/Programming Console key sheet; 20-day power backup to 25°C		3G2A5-PID01-E
Position Control Unit	Position Control Unit: 3G2A5-NC101-E with input multiplier for greater resolution and greater processing speed		3G2A5-NC103-E
	Position Control Unit: For stepping motor; one axis		3G2A5-NC111-EV1
	Position Control Unit: For pulse motors; two axes		C500-NC222-E
	Encoder Adapter		3G2A5-AE001
	Teaching Box	For 1 axis	3G2A5-TU001-E
	Connecting Cable: To connect C500-TU002-E Teaching Box to C500-NC222-E.	2 m	C200H-CN222
		4 m	C200H-CN422
Connecting Cable: To connect C500-TU002-E Teaching Box to 3G2A5-NC103-E/NC111-EV1 Position Control Unit.		C500-CN422	
Cam Positioner Unit	External outputs: 8 pts; Words output to PC: 2 (16 pts.)		C500-CP131
ASCII Unit	RAM and EEPROM		C500-ASC04
Ladder Program I/O Unit	Has 40 instructions (same as a C20P.) Input and output points (16 each.)		C500-LDP01-V1
ID Sensor Unit	Microwave type	General-purpose	C500-IDS21
		Long-distance	C500-IDS22
	For the C500-IDS02		C500-IDA02
	For the C500-IDS22		C500-IDA22
Fuzzy Logic Unit	8 inputs, 2 outputs max.		C500-FZ001

CPU Bus Units

The CV-series SYSMAC LINK, SYSMAC BUS/2, and SYSMAC NET Link Units are also classified as CPU Bus Units. CPU Bus Units must be mounted to the proper slots on CPU or Expansion CPU Racks.

Name	Specifications			Model
Temperature Controller Data Link Unit	Connects up to 64 temperature control devices via 2 ports.			CV500-TDL21
BASIC Unit	Must be mounted to CPU or CPU Expansion Rack	RS-232C x 2 RS-422 x 1	RAM	CV500-BSC11
			EEPROM + RAM	CV500-BSC21
		RS-232C x 2 Centronics x 1	RAM	CV500-BSC31
			EEPROM + RAM	CV500-BSC41
		RS-232C x 2 GP-IB x 1	RAM	CV500-BSC51
			EEPROM + RAM	CV500-BSC61
Personal Computer Unit	Without floating-point division	4MB main memory	CV500-VP213-E	
		8MB main memory	CV500-VP217-E	
	With floating-point division	4MB main memory	CV500-VP223-E	
		8MB main memory	CV500-VP227-E	
	CPU Backplane	Exclusively for the Personal Computer Unit		CV500-BC105
	RAM Disk Board	2MB memory		CV500-MR261
	PC Card Interface Board	For PCMCIA 2.1 Type I and II cards		CV500-MP602
	Floppy Disk Drive	One floppy disk drive		CV500-FDD01
Two floppy disk drives		CV500-FDD02		
Hard Disk Unit	80-MB hard disk		CV500-HDD11	
Connecting Cable	Used to join two Hard Disk Units		CV500-CN116	
Hard Disk Drive	For 100 VAC		CV500-HDD01	
	For 200 VAC		CV500-HDD02	
Floppy/Hard Disk Drive	For 100 VAC		CV500-FHD01-E	
	For 200 VAC		CV500-FHD02-E	
Backup Battery	---		CV500-BAT08	
Motion Control Unit	2 axes		CV500-MC221	
	4 axes		CV500-MC421	
	Connecting Cables	Cable length: 2 m		CV500-CN224
		Cable length: 4 m		CV500-CN424
		Cable length: 6 m		CV500-CN624
MC Support Software	For IBM PC/AT or compatible		CV500-ZN3AT1-E	

Network Units and Remote I/O Units

The CV-series SYSMAC LINK, SYSMAC BUS/2, SYSMAC NET Link Units, and Ethernet Units are classified as CPU Bus Units.

Name		Specifications			Model	
SYSMAC LINK Unit		Optical			CV500-SLK11	
		Coaxial			CV500-SLK21	
	Power Feeder Unit	For optical SYSMAC LINK Unit			C1000H-APS01	
SYSMAC BUS/2	Remote I/O Master Unit	Optical type			CV500-RM211	
		Wire type			CV500-RM221	
	Remote I/O Slave Unit	Optical type			CV500-RT211	
		Wire type			CV500-RT221	
Ethernet Unit		Supports TCP/IP and UDP/ID			CV500-ETN01	
SYSMAC BUS	Optical Remote I/O Master Unit	APF/PCF			3G2A5-RM001-PEV1	
		PCF			3G2A5-RM001-EV1	
	Optical Remote I/O Slave Unit	APF/PCF	W/1 optical connector		3G2A5-RT001-PEV1	
			W/2 optical connectors		3G2A5-RT002-PEV1	
		PCF	W/1 optical connector		3G2A5-RT001-EV1	
			W/2 optical connectors		3G2A5-RT002-EV1	
	Optical I/O Link Unit	APF/PCF			3G2A5-LK010-PE	
		PCF			3G2A5-LK010-E	
	CompoBus/D Master Unit		---			CVM1-DRM21
	Wired Remote I/O Master Unit		---			C500-RM201
Wired Remote I/O Slave Unit		---			C500-RT201	
SYSMAC BUS Optical I/O Units	DC Input	No-voltage contact	8 pts	100-VAC power supply	APF/PCF	3G5A2-ID001-PE
					PCF	3G5A2-ID001-E
	AC/DC Input	12 to 24 VAC/DC	8 pts		APF/PCF	3G5A2-IM211-PE
					PCF	3G5A2-IM211-E
	AC Input	100 VAC	8 pts		APF/PCF	3G5A2-IA121-PE
					PCF	3G5A2-IA121-E
	Contact Output	2 A, 250 VAC/ 24 VDC	8 pts	100/200-VAC power supply	APF/PCF	3G5A2-OC221-PE
					PCF	3G5A2-OC221-E
	Triac Output	100/200 VAC	8 pts		APF/PCF	3G5A2-OA222-PE
					PCF	3G5A2-OA222-E
	Transistor Output	0.3 A, 12 to 48 VDC	8 pts		APF/PCF	3G5A2-OD411-PE
					PCF	3G5A2-OD411-E

Miscellaneous Remote I/O System Units

Link Adapters with the suffix -P in the model number can be extended up to 200 m by using plastic-clad optical fiber cable. Those without the suffix -P in the model number can be extended up to 800 m.

Name	Specifications	Model
Link Adapter	RS-422, 3 pcs	3G2A9-AL001
	Optical (APF/PCF), 3pcs	3G2A9-AL002-PE
	Optical (PCF), 3pcs	3G2A9-AL002-E
	Optical (APF/PCF), RS-422, RS-232C, 1 pc each	3G2A9-AL004-PE
	Optical (PCF), RS-422, RS-232C, 1 pc each	3G2A9-AL004-E
	Optical (APF/PCF), optical (AGF), 1 pc each	3G2A9-AL005-PE
	Optical (PCF), optical (AGF), 1 pc each	3G2A9-AL005-E
	Optical (APF/PCF), optical (AGF), 2 pcs each	3G2A9-AL006-PE
	Optical (PCF), optical (AGF), 2 pcs each	3G2A9-AL006-E
	Optical (APF/PCF), 1 pc, RS-485 1 pc for Wired Remote I/O system only	B500-AL007-P
Repeater	APF/PCF	3G5A2-RPT01-PE
	PCF	3G5A2-RPT01-E

All Plastic Optical-Fiber Cable (APF)

Name	Specifications	Model
Plastic Optical Fiber Cable	Cable only, 5 to 100 m in multiples of 5 m, or multiples of 200 or 500 m	3G5A2-PF002
Optical Connector A	2 pcs (brown), for plastic optical fiber 10 m long max.	3G5A2-CO001
Optical Connector B	2 pcs (black) for plastic optical fiber 8 to 20 m long	3G5A2-CO002
Plastic Optical Fiber Cable	1 m, w/optical connector A provided at both ends	3G5A2-PF101

Plastic-Clad Optical-Fiber Cable (PCF)

Name	Specifications	Model	
Optical Fiber Cable (indoor)	0.1 m, w/connector	Ambient temperature: -10° to 70°C	3G5A2-OF011
	1 m, w/connector		3G5A2-OF101
	2 m, w/connector		3G5A2-OF201
	3 m, w/connector		3G5A2-OF301
	5 m, w/connector		3G5A2-OF501
	10 m, w/connector		3G5A2-OF111
	20 m, w/connector		3G5A2-OF211
	30 m, w/connector		3G5A2-OF311
	40 m, w/connector		3G5A2-OF411
	50 m, w/connector		3G5A2-OF511
Optical Fiber Cable (indoor/outdoor)	1 to 500 m (order in units of 1 m)	Ambient temperature: -10° to 70°C	3G5A2-OF002
	501 to 800 m (order in units of 1 m)		

Hard-plastic-clad Quartz Fiber Cable: H-PCF

Up to 800 m of H-PCF cable can be used between Units in the following systems: SYSMAC NET, SYSMAC LINK, and SYSMAC BUS/2. In the SYSMAC BUS system, up to 100 m of H-PCF cable can be used between Units whose model number suffix contains a P and up to 200 m between other Units whose model number does not contain a P.

You can use connector-equipped cables or assemble cables yourself. The following are required to assemble H-PCF cable: the cable itself, Optical Connectors, Cable Assembly Tool, Cable Cutter Optical Power Tester, Head Unit, and Master Fiber. The user must assemble and test the optical connectors. Refer to the *H-PCF Installation Manual* for details.

H-PCF cables can be used at an ambient temperature of between -20° and 70° C.

H-PCF Optical Fiber Cords and Cables

Cable type	Cable color	Cable length	Model
Two optical conductors with feeder	Black	10 meters	S3200-HCLB101
		50 meters	S3200-HCLB501
		100 meters	S3200-HCLB102
		500 meters	S3200-HCLB502
		1,000 meters	S3200-HCLB103
	Orange	10 meters	S3200-HCLO101
		50 meters	S3200-HCLO501
		100 meters	S3200-HCLO102
		500 meters	S3200-HCLO502
		1,000 meters	S3200-HCLO103
Without feeder	Black	10 m	S3200-HCCB101
		50 m	S3200-HCCB501
		100 m	S3200-HCCB102
		500 m	S3200-HCCB502
	Orange	10 m	S3200-HCCO101
		50 m	S3200-HCCO501
		100 m	S3200-HCCO102
		500 m	S3200-HCCO502
Two-core optical cord	Black	10 m	S3200-HBCB101
		50 m	S3200-HBCB501
		100 m	S3200-HBCB102
		500 m	S3200-HBCB502
		1,000 m	S3200-HBCB103

H-PCF Optical Fiber Cords and Cables with Connectors

The following diagram illustrates the model number for cables with connectors. Tension members and power lines are provided in the cable. Half-lock connectors use the S3200-COCF2511 and are compatible with C200H SYSMAC LINK or SYSMAC NET Link Unit connectors. Full-lock connectors use the S3200-COCF2011 and are compatible with CV-series SYSMAC LINK or SYSMAC NET and C1000H SYSMAC LINK Link Unit connectors. Full-lock connectors cannot be used with C200H connectors.

The above connectors cannot be used with C500 SYSMAC NET Link Unit connectors, cable relays, or NSB. Refer to the *SYSMAC NET Link System Manual* for appropriate connectors for these applications.

S3200-CN□□□-□□-□□

Cable Length	Connector Type
201 2 m	20-20 Full-lock connector on each end
501 5 m	20-25 One full-lock and one half-lock connector
102 10 m	25-25 Full lock connector on each end
152 15 m	
202 20 m	
Blank Over 20 m*	*Specify lengths over 20 m separately when ordering.

Optical Connectors

Name	Model
SYSMAC NET: CV500-SNT31	S3200-COCF2011
SYSMAC LINK: CV500-SLK11, C1000H-SLK11	
SYSMAC BUS/2: CV500-RM211/RT211	
SYSMAC NET: C200H-SNT31	S3200-COCF2511
SYSMAC LINK: C200H-SLK11	
SYSMAC NET: C500-SNT31-V4 S3200-LSU03-01E/NSB11-E S3200-NSUA1-00E/NSUG4-00E FIT10-IF401	S3200-COCH62M
SYSMAC BUS: 3G2A5-RM001-(P)EV1 3G2A5-RT001/RT002-(P)EV1 3G2A9-AL□□-(P)E	S3200-COCH82
SYSMAC NET Relay (M) Connector	S3200-COCF62M
SYSMAC NET Relay (F) Connector	S3200-COCF62F

Cable Assembly Tool and Cutter

Name	Model
Cable Assembly Tool	S3200-CAK1062

Optical Power Tester

Name	Model
SYSMAC NET: CV500-SNT31	S3200-CAT2000
SYSMAC LINK: CV500-SLK11	S3200-CAT2700
SYSMAC BUS/2: CV500-RM211/RT211	
SYSMAC BUS: 3G2A5-RM001-(P)EV1 3G2A5-RT001/RT002-(P)EV1	S3200-CAT2820
SYSMAC NET: S3200-LSU03-01E FIT10-IF401	S3200-CAT3200

Note Each Optical Power Tester is provided with a replaceable Head Unit. There is no difference in type among all Optical Power Testers except for the head unit. This means the S3200-CAT2000 Optical Power Tester, for example, can be used as the S3200-CAT2700, S3200-CAT2820, or S3200-CAT3200 Optical Power Tester by just replacing the Head Unit of the S3200-CAT2000 with those for the S3200-CAT2700, S3200-CAT2820, or S3200-CAT3200.

Optical Power Tester Head Unit

Name	Model
SYSMAC NET: CV500-SNT31	S3200-CAT2002
SYSMAC LINK: CV500-SLK11	S3200-CAT2702
SYSMAC BUS/2: CV500-RM211/RT211	
SYSMAC BUS: 3G2A5-RM001-(P)EV1 3G2A5-RT001/RT002-(P)EV1	S3200-CAT2822
SYSMAC NET: S3200-LSU03-01E FIT10-IF401	S3200-CAT3202

Peripheral Devices

Name	Specifications	Model	
CV Support Software Version 2 (CVSS) (See note)	Runs on an IBM PC/AT-compatible computer	3 1/2"	CV500-ZS3AT1-EV2
SYSMAC Support Software (SSS) (See note)	Runs on an IBM PC/AT-compatible computer	3 1/2"	C500-ZL3AT1-E
Memory Card Writer	---		CV500-MCW01-E
Graphic Programming Console (GPC)	Connecting cable sold separately.		C500-GPC03-E
Connecting cable	Recommended for GPC	2 m	CV500-CN225
		5 m	CV500-CN525
GPC System Memory Cassette (See note.)	---		CV500-MP311-E
GPC Memory Card Adapter	---		CV500-MCA01
Programming Console	For CVM1/CV-series PCs only, cable required separately.		CVM1-PRS21-EV1

Note The CVSS does not support new instructions added for version-2 CVM1 PCs. The SSS does not support the CV500, CV1000, or CV2000.

Optional

Name	Specifications	Model
Battery	---	3G2A5-BAT08
Memory Card Battery	---	HMC-BAT01
DC Power Supply	100 to 120/200 to 240 switchable, 300 W	S82F-3024
Relay	24 VDC	G6B-1174P-FD-US-M
I/O Terminal Cover	For 38-pin block, special type	3G2A5-COV11
	For 38-pin block, standard	C500-COV12
	For 20-pin block, standard	C500-COV13
Connector Cover (see note)	Protector for I/O bus connector	3G2A5-COV01
	Protector for CPU bus connector	CV500-COV01
	Protector for Expansion I/O Rack IOIF connector	CV500-COV02
	Protector for CPU Rack IOC or Expansion CPU Rack IOIF connector	CV500-COV03
	Protector for Simple Expansion I/O Rack connector	CV500-COV04
Space Unit	For I/O Unit	3G2A5-SP002

Note The following shows where the Connector Covers are to be applied.

CPU Rack

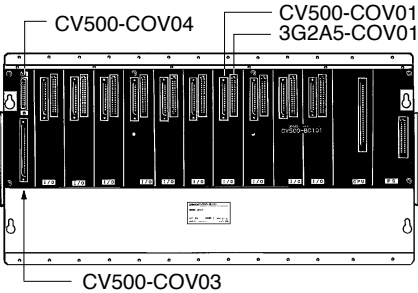

Expansion CPU Rack

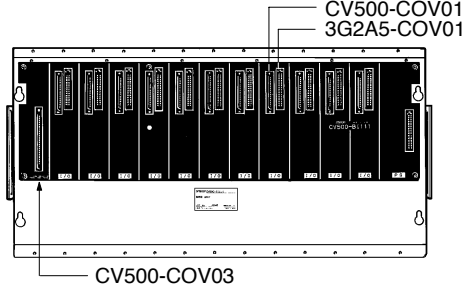

Expansion I/O Rack

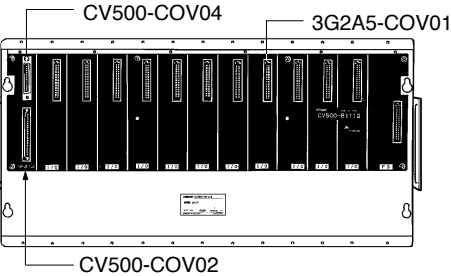

Appendix B Specifications

Power Supply Units

Item	CVM1-PA208	CV500-PS221	CV500-PS211
Supply voltage	100 to 120 or 200 to 240 VAC, 50/60 Hz		24 VDC
Operating voltage range	85 to 132 or 170 to 264 VAC		20.4 to 28.8 VDC
Power consumption	150 VA max.	200 VA max.	100 W max.
Inrush current	30 A max.		30 A max.
Output capacity	8 A, 5 VDC	12 A, 5 VDC	12 A, 5 VDC
Insulation resistance	20 M Ω min. (at 500 VDC) between AC external terminals and \ominus (GR) terminals. (See note 1.)		
Dielectric strength	2,300 VAC 50/60 Hz for 1 min between AC external and \ominus (GR) terminals, leakage current: 10 mA max. 1,000 VAC 50/60 Hz for 1 min between DC external and \ominus (GR) terminals, leakage current: 20 mA max. (See note 1.)		
Noise immunity	1,000 Vp-p, pulse width: 100 ns to 1 μ s, rise time: 1 ns (via noise simulation)		
Vibration resistance	10 to 58 Hz, 0.075-mm amplitude, 58 to 150 Hz, acceleration: 9.8 m/s ² (see note 2) in X, Y, and Z directions for 80 minutes (Time coefficient; 8 minutes x coefficient factor 10 = total time 80 minutes) (according to JIS C0040)		
Shock resistance	147 m/s ² 3 times each in X, Y, and Z directions (according to JIS C0041)		
Ambient temperature	Operating: 0° to 55°C Storage: -20° to 75°C (except Memory Card and battery)		
Humidity	10% to 90% (with no condensation)		
Atmosphere	Must be free from corrosive gasses		
Grounding	Less than 100		
Enclosure	Mounted in a panel		
Weight	All models are each 9 kilograms max.		
Dimensions (without cables, see note 3)	CPU (10 slots)/Expansion CPU/Expansion I/O (11 slots): 480 x 250 x 123 mm (WxHxD) CPU (5 slots)/Expansion I/O (6 slots): 306 x 250 x 123 mm (WxHxD) CPU (3 slots)/Expansion I/O (4 slots): 236 x 250 x 123 mm (WxHxD)		

Note 1. Disconnect the \oplus (LG) terminal of the Power Supply Unit from the \ominus (GR) terminal when performing insulation and dielectric strength tests. If the tests are repeatedly performed with the \oplus (LG) and \ominus (GR) terminals short-circuited, the internal components may be damaged.

2. Acceleration (G)

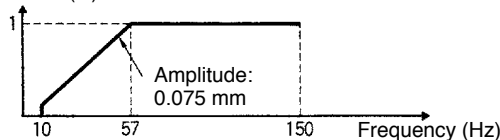

3.

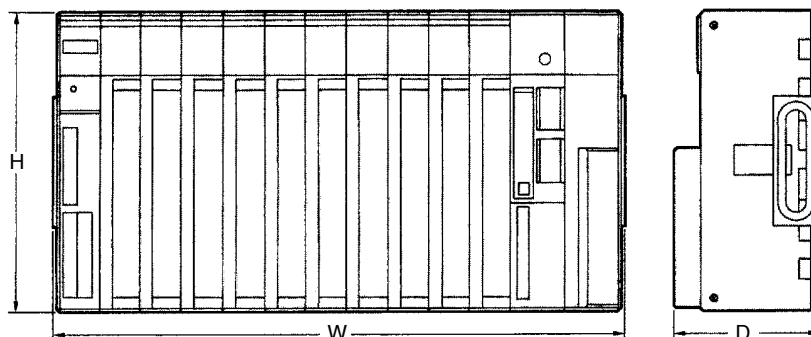

CPU Specifications

Item		Specifications					
CPU		CVM1-CPU01-EV2	CVM1-CPU11-EV2	CVM1-CPU21-EV2	CV500-CPU01-EV1	CV1000-CPU01-EV1	CV2000-CPU01-EV1
Control method		Stored program					
I/O control method		Cyclic, programmed, scheduled, and zero-cross refreshing					
Programming		Ladder	Ladder	Ladder	Ladder or SFC + ladder	Ladder or SFC + ladder	
Instruction length		1 to 8 words/instruction, 1 address/instruction					
Ladder instructions		284 (515 variations)		285 (517 variations)	169 (329 variations)	170 (331 variations)	
Execution time (ms)	Basic	0.15 to 0.45	0.125 to 0.375		0.15 to 0.45	0.125 to 0.375	
	Special	0.60 to 9.90	0.500 to 8.25		0.60 to 9.90	0.500 to 8.25	
Program capacity (See note 1.)		30K words		62K words	30K words	62K words	
Number of SFC steps		SFC not supported.	SFC not supported.	SFC not supported.	512 max.	1,024 max.	
Local I/O capacity		512 pts	1,024 pts	2,048 pts	512 pts	1,024 pts	2,048 pts
Remote I/O capacity	SYSMAC BUS/2	1,024 pts	2,048 pts	2,048 pts	1,024 pts	2,048 pts	
	SYSMAC BUS	512 pts	1,024 pts	2,048 pts	512 pts	1,024 pts	
Remote I/O bits		SYSMAC BUS/2: 12,800 (0200 to 0999); SYSMAC BUS: 4,096 (2300 to 2555)					
Work bits		2,688 (0032 to 0199)	2,176 (0064 to 0199)	1,152 (0128 to 0199)	2,688 (0032 to 0199)	2,176 (0064 to 0199)	1,152 (0128 to 0199)
		4,352 (1964 to 1999, 2064 to 2299)					
Link bits		3,200: 100000 to 119915 (words 1000 to 1199)					
Holding bits		4,800: 120000 to 149915 (words 1200 to 1499)					
CPU Bus Unit bits		6,400: 150000 to 189915 (words 1500 to 1899)					
CompoBus/D data area		2,048: 190000 to 196315 (words 1900 to 1963), 200000 to 206315 (words 2000 to 2063)					
Temporary bits		8 (TR0 to TR7)					
CPU bus link bits		4,096: G00000 to G25515 (words G000 to G255)					
Auxiliary bits		8,192: A00000 to A51115 (words A000 to A511)					
Timers		512 (T0000 to T0511)	1,024 (T0000 to T1023)		512 (T0000 to T0511)	1,024 (T0000 to T1023)	
		Normal timers: 0 to 999.9 s, high-speed timers: 0 to 99.99 s					
Counters		512 (C0000 to C0511)	1,024 (C0000 to C1023)		512 (C0000 to C0511)	1,024 (C0000 to C1023)	
		(0 to 9999 counts)					
Data memory		8,192 words (D00000 to D08191)	24,576 words (D00000 to D24575)		8,192 words (D00000 to D08191)	24,576 words (D00000 to D24575)	
Expansion DM		---		256K words (E00000 to E32765 x 8 banks)	---		256K words (E00000 to E32765 x 8 banks)
Data registers		3 (DR0 to DR2)					
Index registers		3 (IR0 to IR2)					
Step flags		None	None	None	512 (ST0000 to ST0511)	1,024 (ST0000 to ST1023)	
Transition flags		None	None	None	512 (TN0000 to TN0511)	1,024 (TN0000 to TN1023)	
Trace memory		1K words	2K words		1K words	2K words	
File memory		Memory Cards: RAM (512K bytes), EEPROM (128K bytes), or EPROM (1M bytes)					
Control input signal		START input: In RUN mode, PC begins operation when input is ON and halts when it is OFF. Input specifications: 24 VDC, 10 mA					

Item	Specifications
Control output signal	RUN output: The RUN output terminals are ON (closed) while PC is operating. Maximum switching capacity: 250 VAC/2 A (resistive load, $\cos \phi = 1$), 250 VAC/0.5 A (inductive load, $\cos \phi = 0.4$), 24 VDC/2 A (see note 2)
Memory protection	Holding bits (internal status maintained), contents of counters and data memory, SFC execution status (can be set)
Battery life	Service life: 5 years The memory backup time when PC is not powered varies with the ambient temperature. If BAT ERR indicator lights, replace the battery with a new one within 1 week.
Self-diagnostics	CPU failure (watchdog timer), I/O verify error, I/O bus error, memory failure, remote I/O error, battery error, link error, or Special I/O Unit/CPU Bus Unit errors

- Note**
1. The useable program capacity is 28K words or 60K words
 2. To meet the EC Directives (Low Voltage Directive), use the CV500-PS211 at 24 VDC only.

DC Input Units

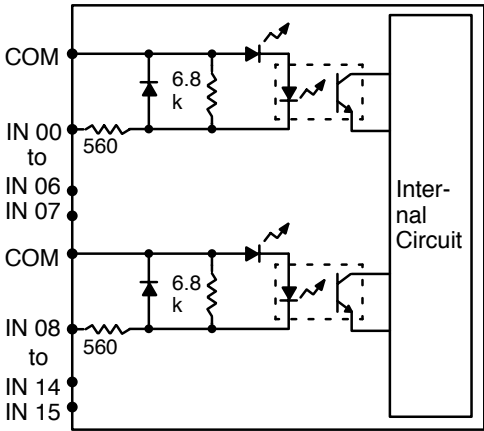
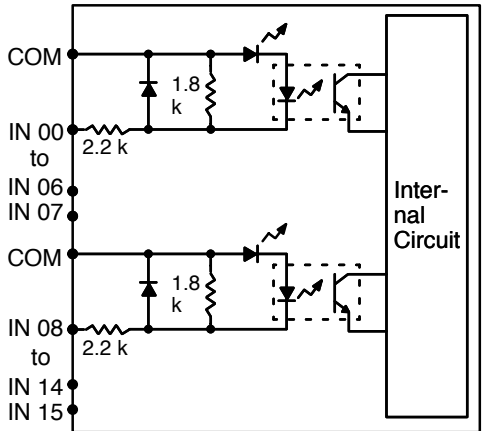
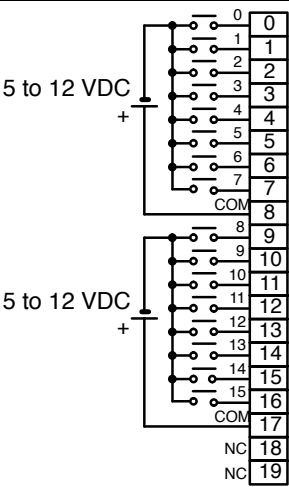
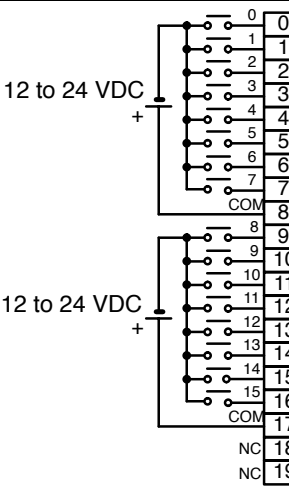
Item	3G2A5-ID112	3G2A5-ID213
Input Voltage	5 to 12 VDC $+10\%/-15\%$	12 to 24 VDC $+10\%/-15\%$
Input Impedance	560	2.2 k
Input Current	16 mA typical (at 12 VDC)	10 mA typical (at 24 VDC)
ON Voltage	4.0 VDC min.	10.2 VDC min.
OFF Voltage	1.5 VDC max.	3.0 VDC max.
ON Delay	1.5 ms max.	1.5 ms max.
OFF Delay	1.5 ms max.	1.5 ms max.
No. of Inputs	16 (8 inputs/common, 2 circuits)	16 (8 inputs/common, 2 circuits)
Internal Current Consumption	10 mA, 5 VDC max.	20 mA, 5 VDC max.
Weight	450 grams max.	450 grams max.
Circuit Configuration	 <p>Two-wire sensors cannot be connected.</p>	
Terminal Connections		
Dimensions	A-shape	A-shape

DC Input Units Continued

Item	3G2A5-ID215	3G2A5-ID218
Input Voltage	12 to 24 VDC +10%/-15%	
Input Impedance	2.2 k	
Input Current	10 mA typical (at 24 VDC)	
ON Voltage	10.2 VDC min.	
OFF Voltage	3.0 VDC max.	
ON Delay	15 ms max.	1.5 ms max.
OFF Delay	15 ms max.	1.5 ms max.
No. of Inputs	32 (8 inputs/common, 4 circuits)	
Internal Current Consumption	160 mA, 5 VDC max.	260 mA, 5 VDC max.
Weight	450 grams max.	
Circuit Configuration		
Terminal Connections		
Dimensions	B-shape	

DC Input Units Continued

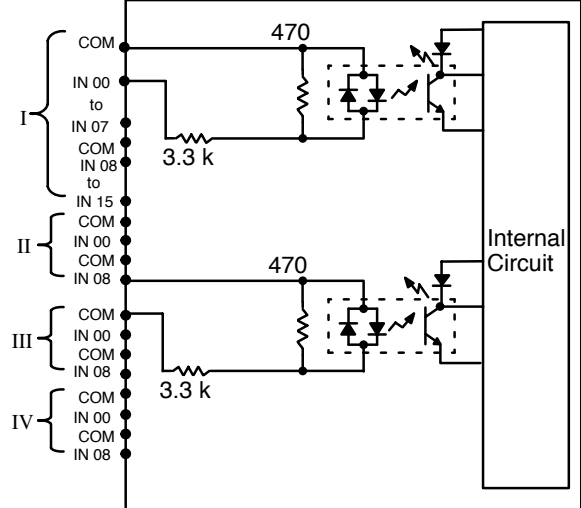
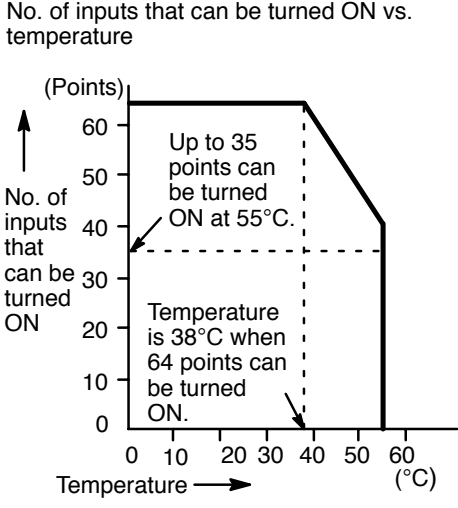
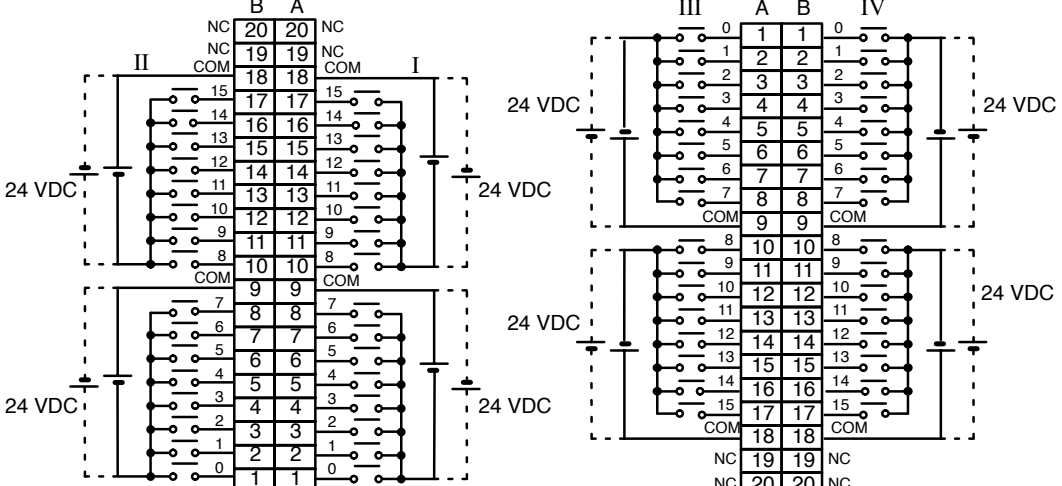
Item	3G2A5-ID219										
Input Voltage	24 VDC +10%/-15%										
Input Impedance	3.3 k										
Input Current	7 mA typical (at 24 VDC)										
ON Voltage	16.0 VDC min.										
OFF Voltage	5.0 VDC max.										
ON Delay	1.5 ms max.										
OFF Delay	1.5 ms max.										
No. of Inputs	64 (8 inputs/common, 8 circuits) (No. of contacts that can be turned ON depends on ambient temperature. See the characteristic data below.)										
Internal Current Consumption	340 mA, 5 VDC max.										
Weight	600 grams max.										
Circuit Configuration	 <p>No. of inputs that can be turned ON vs. temperature</p>  <table border="1"> <caption>Graph Data: No. of inputs that can be turned ON vs. temperature</caption> <thead> <tr> <th>Temperature (°C)</th> <th>No. of inputs that can be turned ON</th> </tr> </thead> <tbody> <tr> <td>0</td> <td>64</td> </tr> <tr> <td>38</td> <td>64</td> </tr> <tr> <td>55</td> <td>35</td> </tr> <tr> <td>60</td> <td>35</td> </tr> </tbody> </table>	Temperature (°C)	No. of inputs that can be turned ON	0	64	38	64	55	35	60	35
Temperature (°C)	No. of inputs that can be turned ON										
0	64										
38	64										
55	35										
60	35										
Terminal Connections											
Dimensions	D-shape										

DC Input Units Continued

Item	C500-ID114
Input Voltage	12 VDC +10%/-15%
Input Impedance	1.5 k
Input Current	7 mA typical (at 12 VDC)
ON Voltage	8.0 VDC min.
OFF Voltage	3.0 VDC max.
ON Delay	1.5 ms max.
OFF Delay	1.5 ms max.
No. of Inputs	64 (8 inputs/common, 8 circuits) (No. of contacts that can be turned ON depends on ambient temperature. See the characteristic data below.)
Internal Current Consumption	340 mA, 5 VDC max.
Weight	600 grams max.
Circuit Configuration	
Terminal Connections	
Dimensions	D-shape

DC Input Units Continued

Item	C500-ID218CN
Input Voltage	12 to 24 VAC $+10\%$ / -15%
Input Impedance	2.2 k
Input Current	10 mA typical (at 24 VDC)
ON Voltage	10.2 VDC min.
OFF Voltage	3.0 VDC max.
ON Delay	1.5 ms max.
OFF Delay	1.5 ms max.
No. of Inputs	32 (8 inputs/common, 4 circuits)
Internal Current Consumption	200 mA, 5 VDC max.
Weight	450 grams max.
Circuit Configuration	
Terminal Connections	
Dimensions	E-shape, with no 4-terminal block

Dynamic DC Input Unit

3G2A5-ID212			
Inputs		Outputs	
Input Voltage	24 VDC +10%/−15%	Max. Switching Capacity	0.1A, 24 VDC +10%/−15%
Input Impedance	2.2 k	Leakage Current	0.1 mA max.
Input Current	10 mA typical (at 24 VDC)	Residual Voltage	1.5 V max.
ON Voltage	10.2 VDC min.	ON Delay	0.2 ms max.
OFF Voltage	3.0 VDC max.	OFF Delay	0.3 ms max.
ON Delay	1.5 ms max.	Power for External Supply	24 VDC ±10%
OFF Delay	1.5 ms max.		

General Specifications

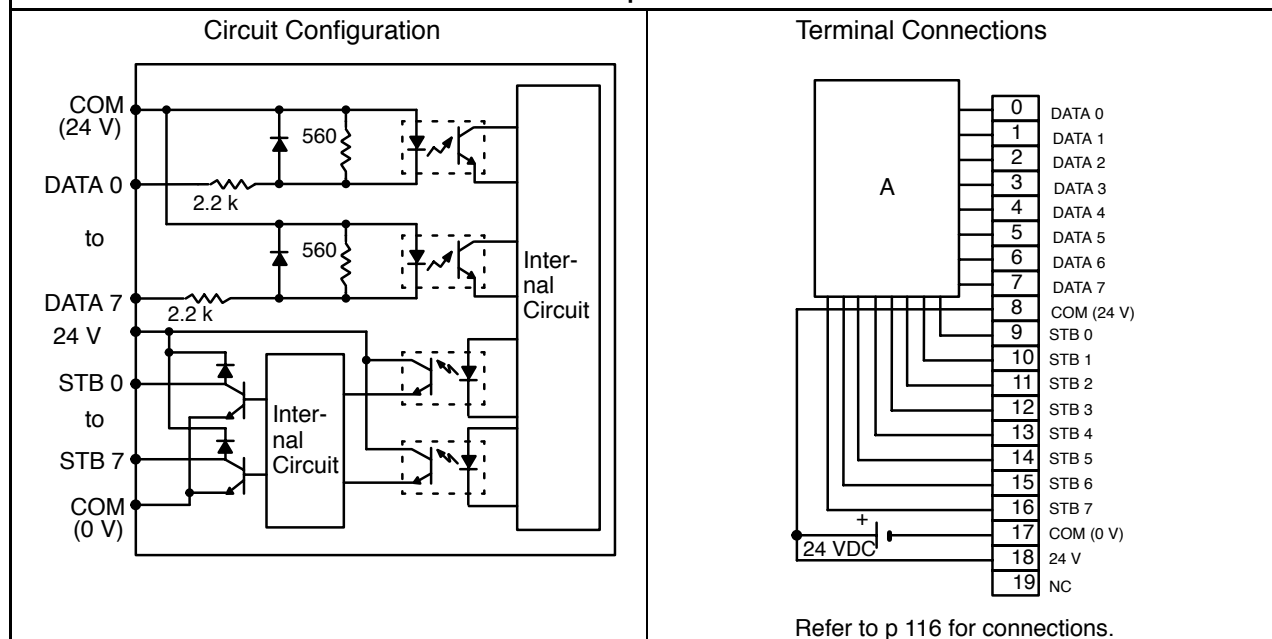

No. of Inputs	64, dynamic
Internal Current Consumption	300 mA, 5 VDC max.
Weight	450 grams max.
Dimensions	A-shape

Wiring Dynamic Inputs

When a large number of bits must be controlled, an ID212 DC Input Unit can simplify wiring by inputting status to up to 64 bits through only 16 points. Using digital switches or a specially wired keyboard, the different combinations of input points will determine which bits are ON. Two examples of connections using digital switches or a keyboard are given.

Connection Example 1 (Keyboard)

The wiring diagram and table below show how the ID212 DC Input Unit can be wired using a specially wired keyboard. For example, if A on the keyboard is pressed, the combination of inputs on DATA 0 and STB 9 turn ON bit 00 of word n. Similarly, the combination of inputs on DATA 7 and STB 7 turn ON bit 15 of word n+3. The value of word n depends on where the Unit is mounted.

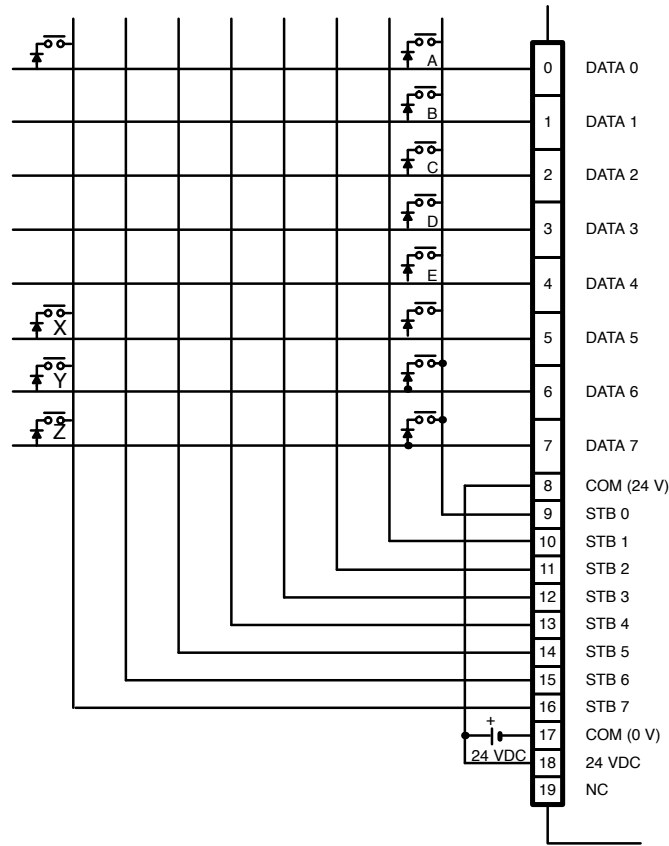

Terminal Number	15	14	13	12	11	10	09	08	07	06	05	04	03	02	01	00
Word n												E	D	C	B	A
Word n + 1																
Word n + 2																
Word n + 3	Z	Y	X													

Note Because the DC Input Unit is operated on an extremely small current, make sure there is adequate distance between the DC Input Unit wires and high-tension equipment or power lines. If this cannot be avoided, use shielded cables when wiring the DC Input Unit. Be sure to keep the total length of the wires less than 10 m.

Connection Example 2 (Digital Switches)

This example shows how the ID212 DC Input Unit can be wired using digital switches. Just as the keys on the keyboard can turn ON different combinations of bits, the digital switches can control different combinations of bits. For example, the combination of inputs on switch no. 1 and input point 00 turn ON bit 00 of word n. (For the sake of simplicity, the figure below shows the digital switches wired to control 32 bits instead of 64 bits as was shown in Example 1.) Wire STB 4, STB 5, STB 6, and STB 7 to access an additional 32 bits.

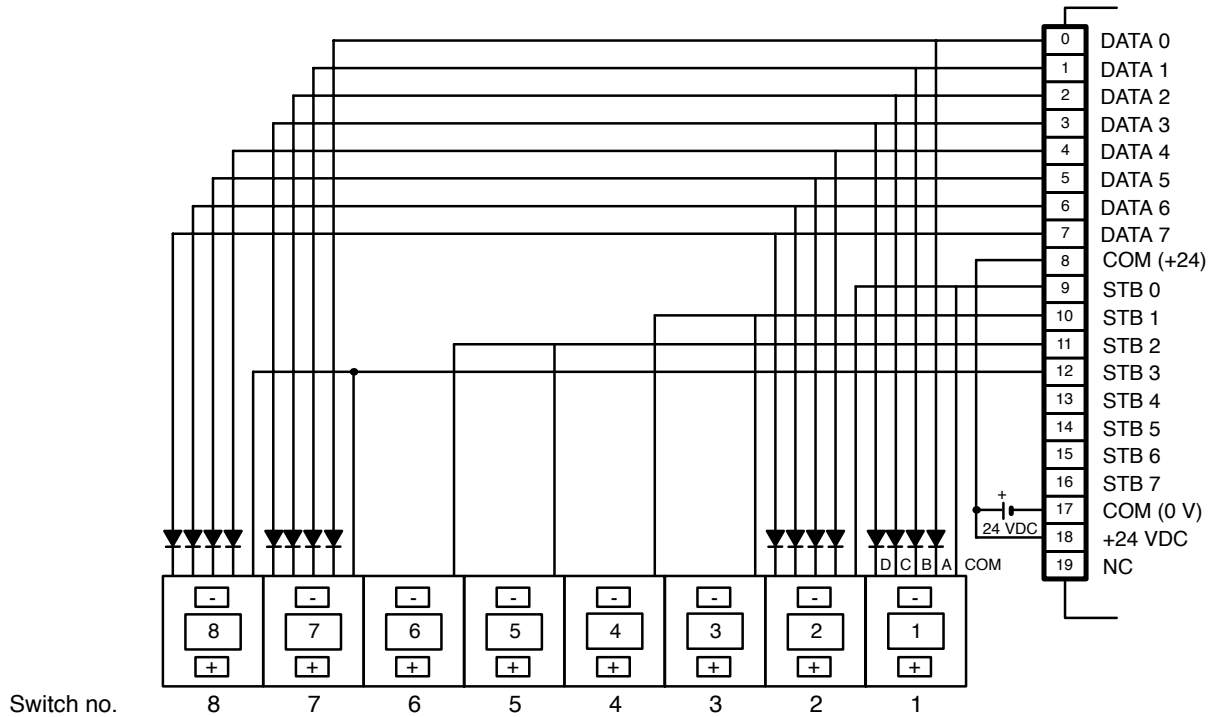

The following table shows the combinations enabled by wiring digital switches as shown.

Terminal Number	15	14	13	12	11	10	09	08	07	06	05	04	03	02	01	00
Word n	Switch no. 4				Switch no. 3				Switch no. 2				Switch no. 1			
	0	1	0	0	0	0	1	1	0	0	1	1	0	0	0	1
	STB 1								STB 0							
Word n + 1	Switch no. 8				Switch no. 7				Switch no. 6				Switch no. 5			
	1	0	0	0	0	1	1	1	0	1	1	0	0	1	0	1
	STB 3								STB 2							

Timing

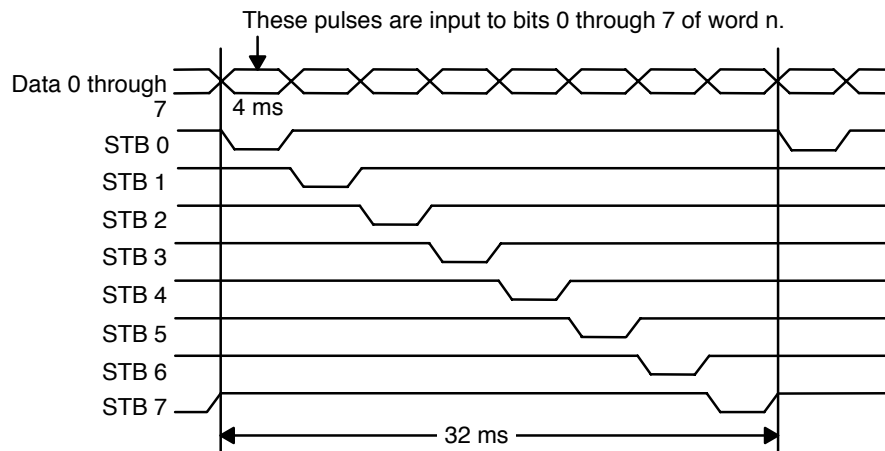

AC Input Units

Item	3G2A5-IA121	3G2A5-IA222
Input Voltage	100 to 120 VAC +10%/-15%, 50/60 Hz	200 to 240 VAC +10%/-15%, 50/60 Hz
Input Impedance	9.7 k (50 Hz), 8 k (60 Hz)	22 k (50 Hz), 18 k (60 Hz)
Input Current	10 mA typical (at 100 VAC)	10 mA typical (at 200 VAC)
ON Voltage	60 VAC min.	120 VAC min.
OFF Voltage	20 VAC max.	40 VAC max.
ON Delay	35 ms max.	35 ms max.
OFF Delay	55 ms max.	55 ms max.
No. of Inputs	16 (8 inputs/common, 2 circuits)	16 (8 inputs/common, 2 circuits)
Internal Current Consumption	180 mA, 5 VDC max.	180 mA, 5 VDC max.
Weight	450 grams max.	450 grams max.
Circuit Configuration		
Terminal Connections		
Dimensions	A-shape	A-shape

AC Input Units Continued

Item	3G2A5-IA122	C500-IA223
Input Voltage	100 to 120 VAC $+10\%/-15\%$, 50/60 Hz	200 to 240 VAC $+10\%/-15\%$, 50/60 Hz
Input Impedance	9.7 k (50 Hz), 8 k (60 Hz)	22 k (50 Hz), 18 k (60 Hz)
Input Current	10 mA typical (at 100 VAC)	10 mA typical (at 200 VAC)
ON Voltage	60 VAC min.	120 VAC min.
OFF Voltage	20 VAC max.	40 VAC max.
ON Delay	35 ms max.	35 ms max.
OFF Delay	55 ms max.	55 ms max.
No. of Inputs	32 (8 inputs/common, 4 circuits)	32 (8 inputs/common, 4 circuits)
Internal Current Consumption	180 mA, 5 VDC max.	180 mA, 5 VDC max.
Weight	600 grams max.	600 grams max.
Circuit Configuration		
Terminal Connections		
Dimensions	C-shape	C-shape

AC/DC Input Units

Item	3G2A5-IM211	3G2A5-IM212
Input Voltage	12 to 24 VAC/DC +10%/-15%, 50/60 Hz	12 to 24 VAC/DC +10%/-15%, 50/60 Hz
Input Impedance	1.8 k	2.2 k
Input Current	10 mA typical (at 24 VDC)	10 mA typical (at 24 VDC)
ON Voltage	10.2 VDC min.	10.2 VDC min.
OFF Voltage	3.0 VDC max.	3.0 VDC max.
ON Delay	15 ms max.	15 ms max.
OFF Delay	15 ms max.	15 ms max.
No. of Inputs	16 (8 inputs/common, 2 circuits)	32 (8 inputs/common, 4 circuits)
Internal Current Consumption	10 mA, 5 VDC max.	200 mA, 5 VDC max.
Weight	450 grams max.	500 grams max.
Circuit Configuration		
Terminal Connections		
Dimensions	A-shape	A-shape

TTL Input Units

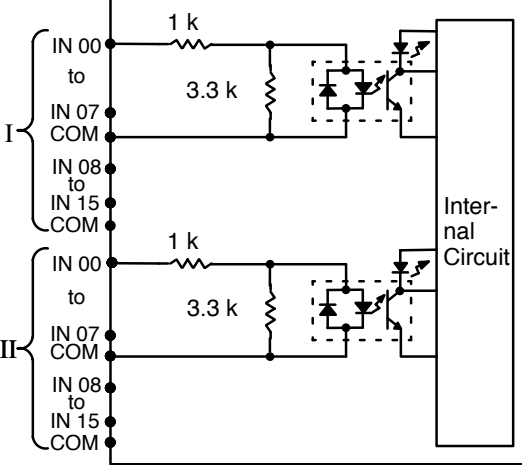
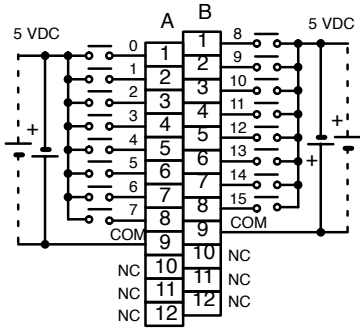
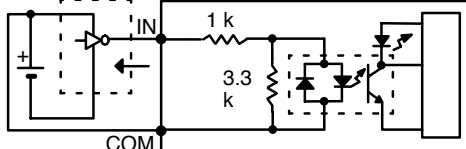
Item	C500-ID501CN
Input Voltage	5 VDC \pm 10%
Input Impedance	1 k
Input Current	3.5 mA typical (at 24 VDC)
ON Voltage	3 VDC min.
OFF Voltage	1 VDC max.
ON Delay	1.5 ms max.
OFF Delay	1.5 ms max.
No. of Inputs	32 (8 inputs/common, 4 circuits)
Internal Current Consumption	200 mA, 5 VDC max.
Weight	450 grams max.
Circuit Configuration	
Terminal Connections	 <p>Use a sinking TTL buffer.</p> <p>(TTL/LS-TTL/CMOS buffer)</p> 
Dimensions	E-shape, with no 4-terminal block

Triac Output Units

Item	3G2A5-OA121	3G2A5-OA222
Max. Switching Capacity	1 A, 132 VAC, 50/60 Hz (4 A/common, 5 A/Unit)	1 A, 250 VAC, 50/60 Hz (4 A/common, 5 A/Unit)
Min. Switching Capacity	10 mA (resistive load) , 10 VAC 40 mA (inductive load), 10 VAC	10 mA (resistive load), 10 VAC 40 mA (inductive load), 10 VAC
Leakage Current	3 mA (100 VAC) max.	3 mA max. at 100 VAC 6 mA max. at 200 VAC
Residual Voltage	1.2 V max.	1.2 V max.
ON Delay	1 ms max.	1 ms max.
OFF Delay	1/2 of load frequency max.	1/2 of load frequency max.
No. of Outputs	16 (8 outputs/common, 2 circuits)	16 (8 outputs/common, 2 circuits)
Internal Current Consumption	300 mA, 5 VDC max.	300 mA, 5 VDC max.
Fuse Capacity	5 A, 250 V (two fuses)	5 A, 250 V (two fuses)
Weight	500 grams max.	500 grams max.
Circuit Configuration	<p>The fuse is 5 A, 250 V and 6.35 mm dia. x 32 mm.</p>	<p>The fuse is 5 A, 250 V; 6.35 mm dia. x 32 mm.</p>
Terminal Connections		
Dimensions	A-shape	A-shape

Triac Output Units Continued

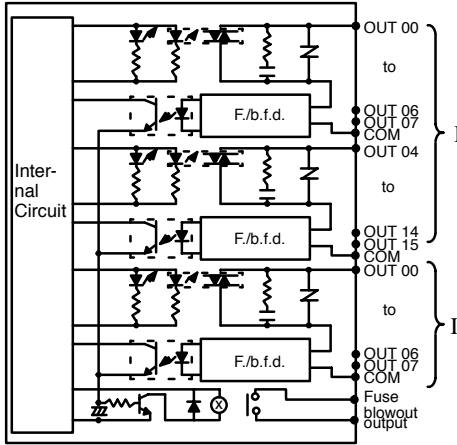
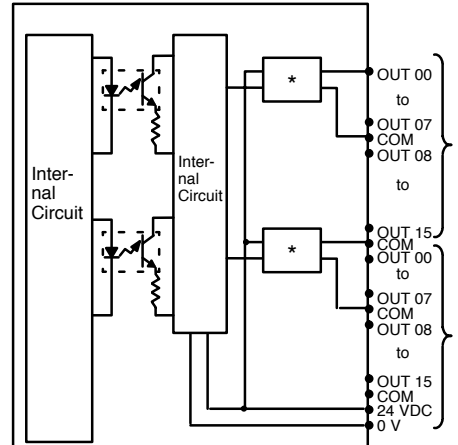
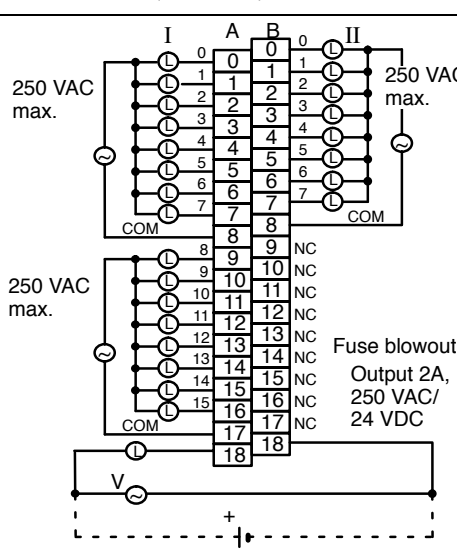
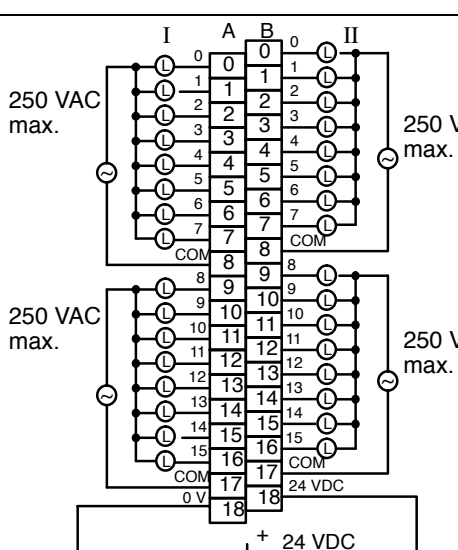
Item	3G2A5-OA223	C500-OA225
Max. Switching Capacity	1 A, 250 VAC, 50/60 Hz (4 A/common, 5 A/Unit)	1 A, 250 VAC, 50/60 Hz (4 A/common, 5 A/Unit)
Min. Switching Capacity	10 mA (resistive load) , 10 VAC 40 mA (inductive load), 10 VAC	10 mA (resistive load) , 10 VAC 40 mA (inductive load), 10 VAC
Leakage Current	3 mA (100 VAC) max., 6 mA (200 VAC) max.	2 mA (100 VAC) max., 5 mA (200 VAC) max.
Residual Voltage	1.2 V max.	1.6 V max.
ON Delay	1 ms max.	1 ms max.
OFF Delay	1/2 of load frequency max.	1/2 of load frequency max.
No. of Outputs	24 (8 outputs/common, 3 circuits)	32 (8 outputs/common, 4 circuits)
Internal Current Consumption	450 mA, 5 VDC max.	200 mA, 5 VDC max.
Fuse Capacity	5 A, 250 V (three fuses)	Not provided
Power for External Supply	---	320 mA, 5 VDC ±10% max.
Weight	600 grams max.	600 grams max.
Circuit Configuration	 <p>F/b. f. d. Fuse/blown fuse detection Fuse: MF51SH (5 A, 250 V)</p>	 <p>* G3S-201PL 24 VDC</p>
Terminal Connections	 <p>250 VAC max.</p> <p>250 VAC max.</p> <p>250 VAC max.</p> <p>Output 2A, 250 VAC/ 24 VDC</p>	 <p>250 VAC max.</p> <p>250 VAC max.</p> <p>250 VAC max.</p> <p>24 VDC</p>
Dimensions	C-shape	C-shape

Special Considerations for C500-OA225

The maximum current value allowed per output point depends on the ambient temperature and the number of points per common that are ON simultaneously. The graph below shows the relationship between the allowable current per point and the number of points ON per common. Be sure not to exceed the values shown in the graph.

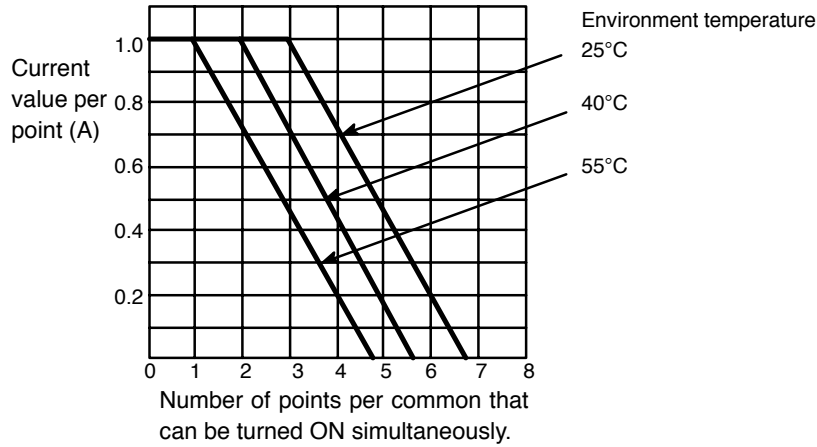

Number of Points per Common Turned ON Simultaneously

The graph below shows the value of the surge current and the time it takes the current to reach a steady state (current-carrying time). The curved line in the graph represents the maximum value of surge current at which the Unit can operate properly. It is suggested that when opening and closing a load with a large surge current, to keep the value of the surge current to half the value shown the graph (within the shaded area).

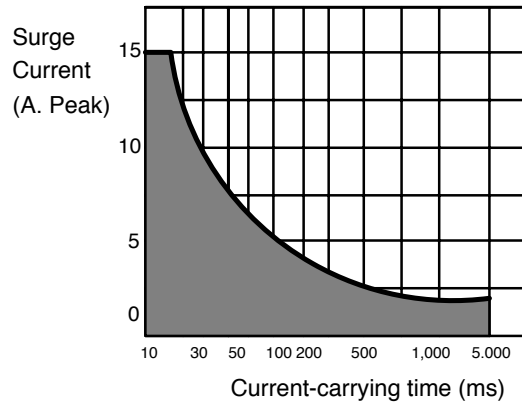

Triac Output Units Continued

Item	C500-OA226
Max. Switching Capacity	1.2 A, 250 VAC, 50/60 Hz (4 A/common, 5 A/Unit)
Max. Inrush Current	15 A (pulse width: 100 ms) 30 A (pulse width: 10 ms)
Min. Switching Capacity	100 mA, 10 VAC 50 mA, 24 VAC 10 mA, 100 VAC 10 mA, 240 VAC
Leakage Current	1.5 mA (120 VAC, 60 Hz) max. 3.0 mA (240 VAC, 60 Hz) max.
Residual Voltage	1.5 VAC (100 to 600 mA) max. 1.5 VAC (50 to 100 mA) max. 5.0 VAC (10 to 50 mA) max.
ON Delay	1 ms max.
OFF Delay	1/2 of load frequency + 1 ms max.
No. of Outputs	16 (8 outputs/common, 2 circuits)
Internal Current Consumption	450 mA, 5 VDC max.
Fuse Capacity	5 A, 250 V, 6.35 dia. x 32 (2 fuses)
Weight	600 grams max.
Circuit Configuration	<p>The fuse is 5 A, 250 V and 6.35 mm dia. x 32 mm.</p>
Terminal Connections	
Dimensions	C-shape

Transistor Output Units

Item	3G2A5-OD411	3G2A5-OD412
Max. Switching Capacity	12 to 48 VDC +10%/-15%, 1 A (but, 4 A/common, 5 A/Unit)	12 to 48 VDC +10%/-15%, 0.3 A (but, 4.8 A/Unit)
Leakage Current	0.1 mA max.	0.1 mA max.
Residual Voltage	1.4 V max.	1.5 V max.
ON Delay	0.2 ms max.	0.2 ms max.
OFF Delay	0.3 ms max.	0.3 ms max.
No. of Outputs	16 (16 outputs/common, 1 circuit)	32 (32 outputs/common, 1 circuit)
Internal Current Consumption	160 mA, 5 VDC max.	230 mA, 5 VDC max.
Fuse Capacity	5 A, 250 V (two fuses)	1 per circuit, 1 total (Cannot be changed by user.)
Power for External Supply	50 mA, 12 to 48 VDC ±10% min.	80 mA, 12 to 48 VDC ±10% min.
Weight	500 grams max.	530 grams max.
Circuit Configuration	<p>* Fuse/fuse blowout detection circuit</p>	
Terminal Connections	<p>12 to 48 VDC</p> <p>Note: Be sure to supply power to B18; otherwise current will leak through the load while the output is OFF. Because the commons are short-circuited internally, they cannot be used separately and must be wired according to the diagram.</p>	<p>12 to 48 VDC</p> <p>Note: Be sure to supply power to B18; otherwise current will leak through the load while the output is OFF. Because the commons are short-circuited internally, they cannot be used separately and must be wired according to the diagram.</p>
Dimensions	A-shape	B-shape

Transistor Output Units Continued

Item	3G2A5-OD414
Max. Switching Capacity	12 to 48 VDC $\pm 10\%$ / -15% , 0.3 A (but, 2.4 A/common; 4.8 A/Unit)
Leakage Current	0.1 mA max.
Residual Voltage	1.5 V max.
ON Delay	0.2 ms max.
OFF Delay	0.3 ms max.
No. of Outputs	32 (16 outputs/common, 2 circuits)
Internal Current Consumption	230 mA, 5 VDC max.
Fuse Capacity	Not provided
Power for External Supply	80 mA, 12 to 48 VDC $\pm 10\%$ min.
Weight	530 grams max.
Circuit Configuration	
Terminal Connections	<p>Supply power to A18 and B18. Without power supplied to A18 and B18, leakage current will cause a malfunction at the load.</p>
Dimensions	B-shape

Transistor Output Units Continued

Item	3G2A5-OD213
Max. Switching Capacity	16 mA/4.5 V to 100 mA/26.4 VDC (See chart below.) (but, 800 mA/common, 6.4 A/Unit)
Leakage Current	0.1 mA max.
Residual Voltage	0.4 V max.
ON Delay	0.2 ms max.
OFF Delay	0.3 ms max.
No. of Outputs	64 (8 outputs/common, 8 circuits)
Internal Current Consumption	460 mA, 5 VDC max. (140 mA + (5 mA x no. of ON points))
Fuse	1 per circuit, 8 total (Cannot be changed by user.)
Power for External Supply	170 mA, 26.4 VDC min. (2.6 mA x no. of ON points)
Weight	550 grams max.
Circuit Configuration	
Terminal Connections	
Dimensions	D-shape

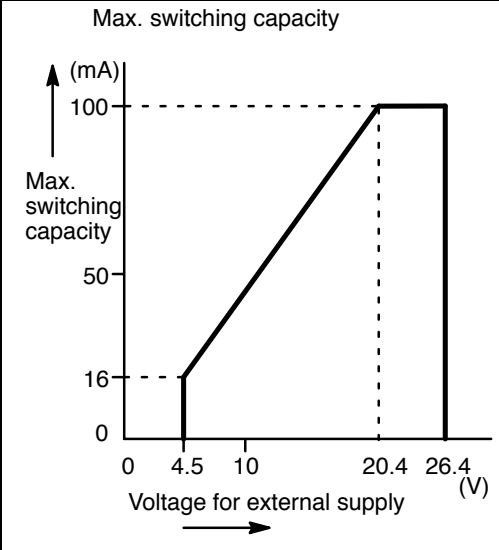

Transistor Output Units Continued

Item	3G2A5-OD215	C500-OD217
Max. Switching Capacity	24 VDC $\pm 10\%$, 50 mA/point	12 to 24 VDC $+10\%/-15\%$, 1 A (but, 4 A/common, 5 A/Unit)
Leakage Current	---	0.1 mA max.
Residual Voltage	1.0 V max.	1.4 V max.
ON Delay	0.2 ms max.	0.2 ms max.
OFF Delay	0.3 ms max.	0.3 ms max.
No. of Outputs	16 (independent commons)	16 (8 outputs/common, 2 circuits)
Internal Current Consumption	200 mA, 5 VDC max.	160 mA, 5 VDC max.
Fuse Capacity	Not provided	5 A, 250 V (two fuses)
Power for External Supply	---	50 mA, 12 to 24 VDC $\pm 10\%$ min.
Weight	530 grams max.	500 grams max.
Circuit Configuration		
Terminal Connections		<p>Note: Be sure to connect Power Supplies to 18 and 19.</p>
Dimensions	B-shape	A-shape

Transistor Output Units Continued

Item	C500-OD218	C500-OD219
Max. Switching Capacity	12 to 24 VDC +10%/-15%, 0.3 A (but, 2.4 A/common, 4.8 A/Unit)	12 to 24 VDC +10%/-15%, 2.1 A (but, 8 A/common, 16 A/Unit)
Leakage Current	0.1 mA max.	0.1 mA max.
Residual Voltage	1.5 V max.	0.7 V max.
ON Delay	0.2 ms max.	0.2 ms max.
OFF Delay	0.3 ms max.	0.4 ms max.
No. of Outputs	32 (16 outputs/common, 2 circuits)	16 (8 outputs/common, 2 circuits)
Internal Current Consumption	230 mA, 5 VDC max.	160 mA, 5 VDC max.
Fuse Capacity	1 per circuit, 2 total (Cannot be changed by user.)	10 A, 250 V (two fuses)
Power for External Supply	80 mA, 12 to 24 VDC ±10% min.	100 mA, 12 to 24 VDC ±10% min.
Weight	530 grams max.	550 grams max.
Circuit Configuration		
Terminal Connections	<p>Note: Be sure to supply power to A18 and B18. A8, A17, B8, and B17 are short-circuited internally, so they cannot be used separately. A8 and B8 do not have to be wired.</p>	<p>Note: Be sure to supply power to 18 and 19.</p>
Dimensions	B-shape	A-shape

Transistor Output Units Continued

Item	C500-OD415CN
Max. Switching Capacity	12 to 48 VDC +10%/-15%, 0.3 A (but, 2.4 A/common, 4.8 A/Unit)
Leakage Current	0.1 mA max.
Residual Voltage	1.5 V max.
ON Delay	0.2 ms max.
OFF Delay	0.3 ms max.
No. of Outputs	32 (16 outputs/common, 2 circuits)
Internal Current Consumption	230 mA, 5 VDC max.
Fuse Capacity	Not provided
Power for External Supply	80 mA, 12 to 48 VDC ±10% min.
Weight	530 grams max.
Circuit Configuration	
Terminal Connections (CNI and CNII)	<p>Note: Power can be supplied to either connector pins A9, B9, A10, and B10 or to terminal block terminals 1 to 4. If power is not supplied, dark current will leak through the load while the output is OFF. The following pins are connected internally: CNI: A9, B9, and terminal 2; A10, B10 and terminal 1. CNII: A9, B9, and terminal 4; A10, B10 and terminal 3</p>
Dimensions	E-shape

Transistor Output Units Continued

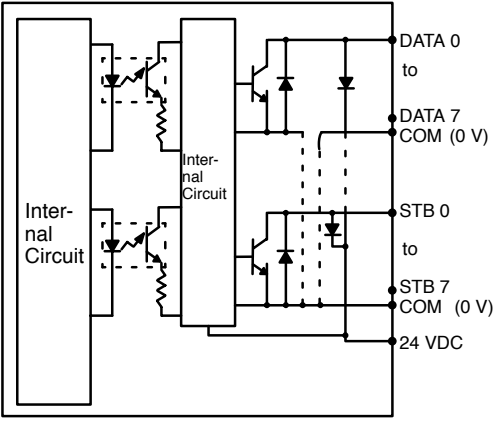
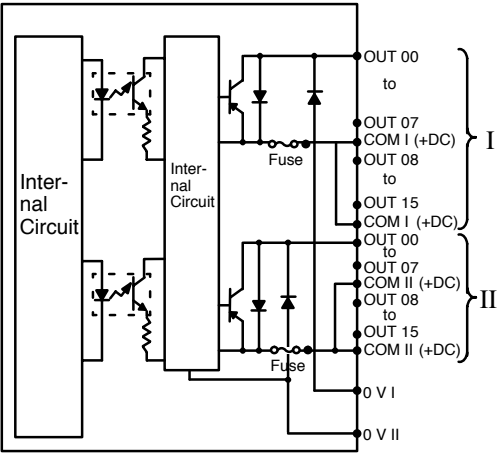
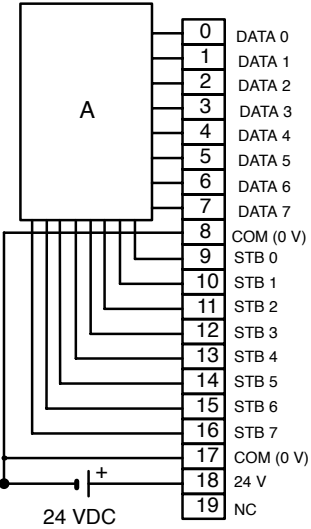
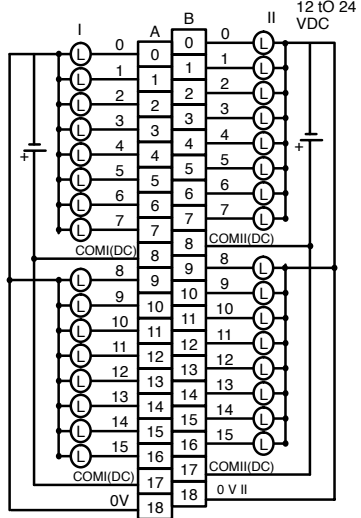
Item	3G2A5-OD211 (dynamic)	3G2A5-OD212 (PNP)
Max. Switching Capacity	24 VDC +10%/−15%	12 to 24 VDC +10%/−15%, 0.3 A (but, 2.4 A/common, 4.8 A/Unit)
Leakage Current	0.1 mA max.	0.1 mA max.
Residual Voltage	1.5 V max.	1.5 V max.
ON Delay	0.2 ms max.	0.2 ms max.
OFF Delay	0.3 ms max.	0.3 ms max.
No. of Outputs	64 (dynamic)	32 (16 outputs/common, 2 circuits)
Internal Current Consumption	300 mA, 5 VDC max.	230 mA, 5 VDC max.
Fuses	Not provided.	1 per circuit, 2 total (Cannot be changed by user.)
Power for External Supply	50 mA, 24 VDC ±10% min.	50 mA, 12 to 24 VDC ±10% min.
Weight	450 grams max.	530 grams max.
Circuit Configuration	 <p>DATA: Positive logic output STB: Negative logic output</p>	
Terminal Connections	<p>Terminal Connections</p>  <p>Refer to p 122 for wiring examples.</p>	 <p>Note: A8 and A17 are connected internally, as are B8 and B17; they cannot be used independently. Wire according to the diagram to prevent insufficient current flow.</p>
Dimensions	A-shape	B-shape

Wiring Dynamic Outputs (3G2A5-OD211)

By using the OD211 DC Output Unit, a large number of outputs can be controlled through only 16 bits. Just like the ID211 DC Input Unit, different combinations of bits can control different outputs. Using this type of Unit can simplify wiring when many outputs must be controlled. Up to 64 outputs can be accessed.

Because the output data is positive logic, a terminal output goes high when the output bit is ON (1). A strobe output is negative logic, so when the output bit is ON (1), the corresponding terminal goes low. Use positive logic output devices for the load of this Unit. The strobe output is cyclic and automatically output.

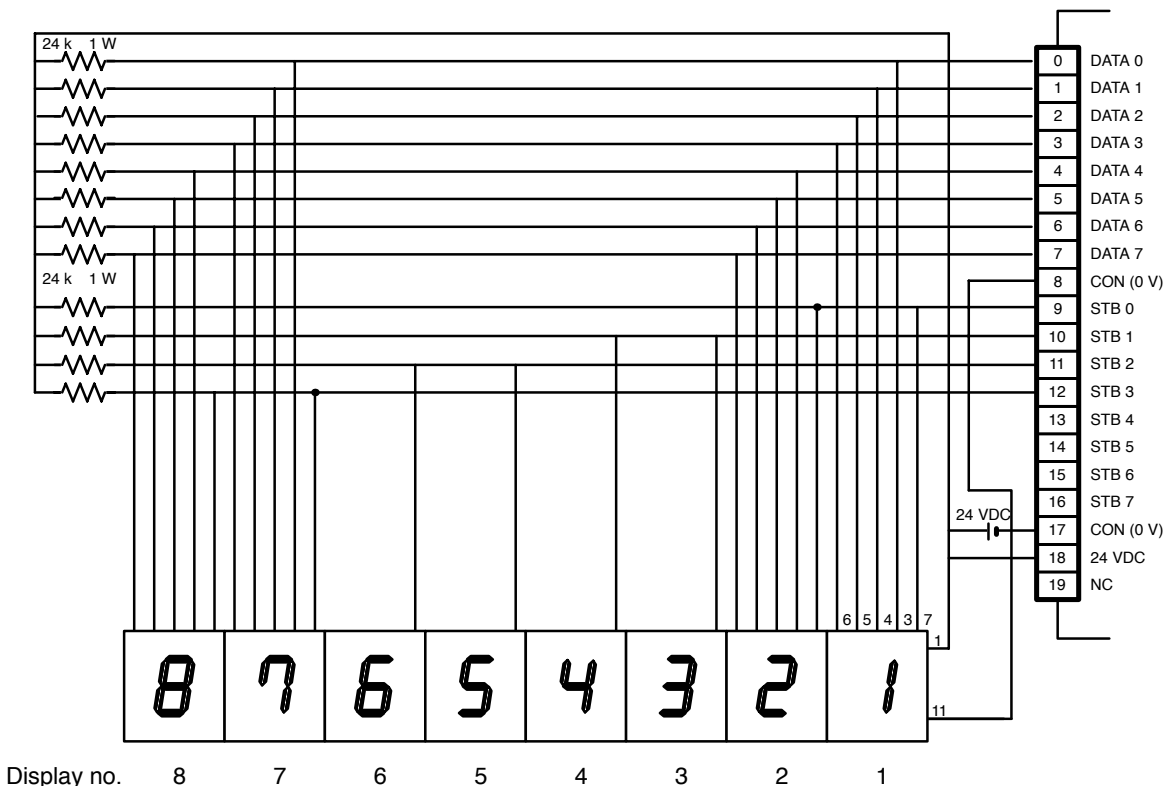

The following table shows the combinations made possible when the display is wired as shown in the previous figure. The value of word n depends on where the Unit.

Point Number	15	14	13	12	11	10	09	08	07	06	05	04	03	02	01	00
Data Number	07	06	05	04	03	02	01	00	07	06	05	04	03	02	01	00
Word n	Display no. 4				Display no. 3				Display no. 2				Display no. 1			
	0	1	0	0	0	0	1	1	0	0	1	0	0	0	0	1
Word n + 1	STB 1				STB 0				STB 3				STB 2			
	1	0	0	0	0	1	1	1	0	1	1	0	0	1	0	1

Note Because the DC Input Unit is operated on an extremely small current, make sure there is adequate distance between the DC Input Unit wires and high-tension equipment or power lines. If this cannot be avoided, use shielded cables when wiring the DC Input Unit. Be sure to keep the total length of the wires less than 10 m.

Timing

The following timing chart illustrates the operation of the Output Unit when wired as shown on the previous page.

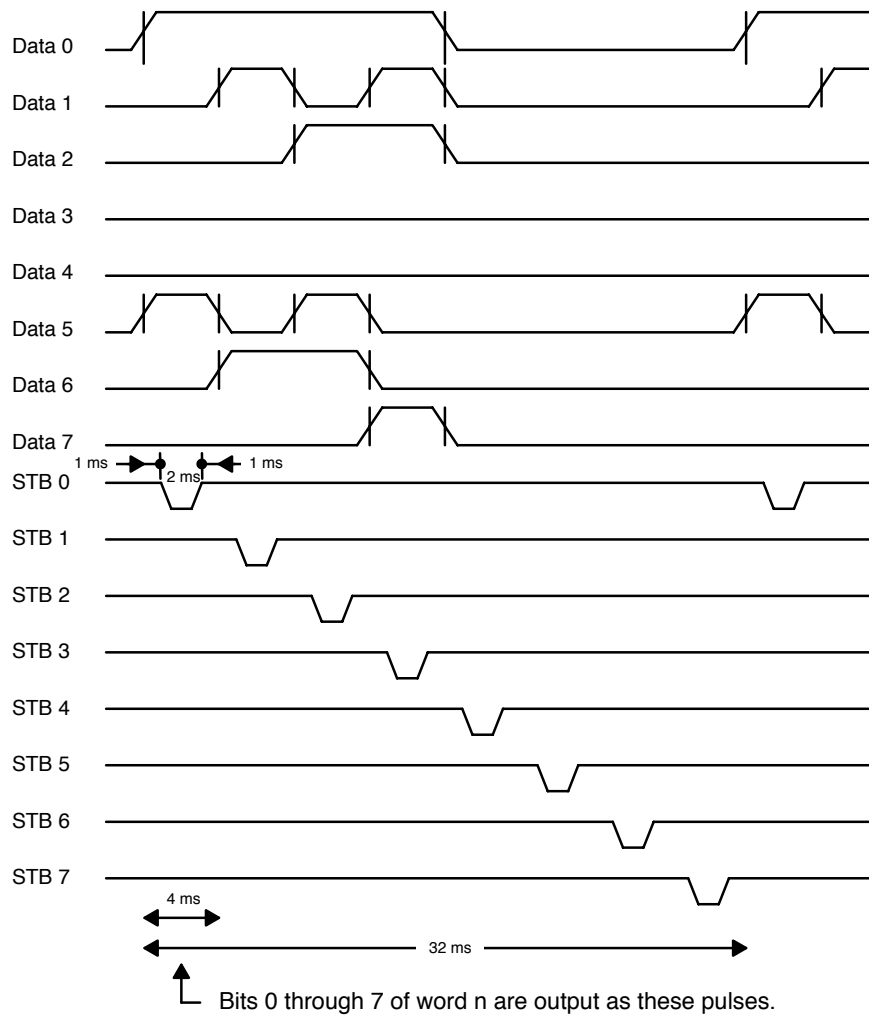

Contact Output Units

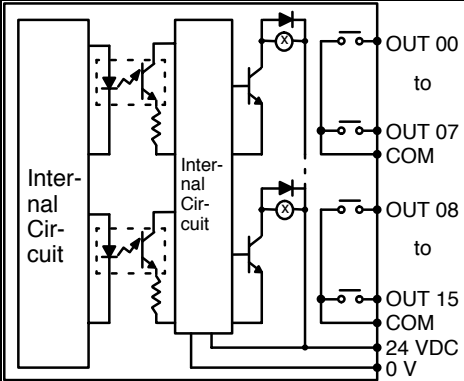
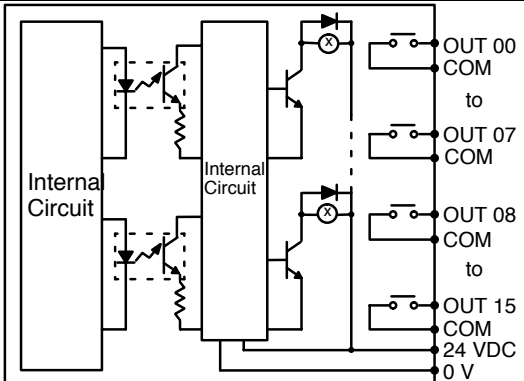
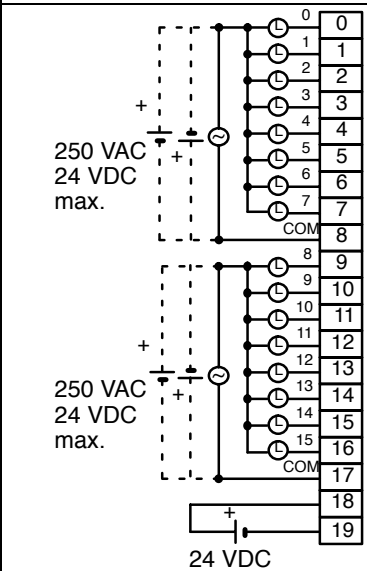
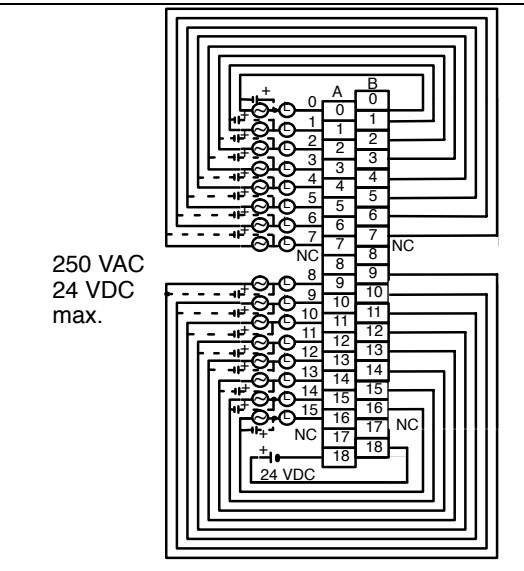
Item	3G2A5-OC221	3G2A5-OC223
Max. Switching Capacity	2 A, 250 VAC (cos = 1), 0.5 A, 250 VAC (cos = 0.4) 2 A, 24 VDC (but, 8 A/common, 16 A/Unit)	2 A, 250 VAC (cos = 1), 0.5 A, 250 VAC (cos = 0.4), 2 A, 24 VDC (but, 32 A/Unit)
Min. Switching Capacity	10 mA, 5 VDC	10 mA, 5 VDC
Power for External Supply	Voltage: 24 VDC \pm 10 % Current: 10 mA/point, 160 mA/Unit	Voltage: 24 VDC \pm 10 % Current: 10 mA/point, 160 mA/Unit
Relay	G6B-114P-FD-US-M (24 VDC) w/socket	G6B-114P-FD-US-M (24 VDC) w/socket
Service Life of Relay	Electrical: 300,000 operations (resistive load) 100,000 operations (inductive load) Mechanical: 50,000,000 operations	Electrical: 300,000 operations (resistive load) 100,000 operations (inductive load) Mechanical: 50,000,000 operations
ON Delay	15 ms max.	15 ms max.
OFF Delay	15 ms max.	15 ms max.
No. of Outputs	16 (8 outputs/common, 2 circuits)	16 (independent commons)
Internal Current Consumption	100 mA, 5 VDC max.	100 mA, 5 VDC max.
Weight	450 grams max.	450 grams max.
Circuit Configuration	 <p>Relays are mounted on sockets and are replaceable.</p>	 <p>Relays are mounted on sockets and are replaceable.</p>
Terminal Connections		
Dimensions	A-shape	B-shape

Contact Output Units Continued

Item	3G2A5-OC224
Max. Switching Capacity	2 A, 250 VAC (cos = 1), 0.5 A, 250 VAC (cos = 0.4) 2 A, 24 VDC (8 A/common, 32 A/Unit)
Min. Switching Capacity	10 mA, 5 VDC
Power for External Supply	Voltage: 24 VDC ±10 % Current: 10 mA/point, 320 mA/Unit
Relay	G6B-114P-FD-US-M (24 VDC) w/socket
Service Life of Relay	Electrical: 300,000 operations (resistive load) 100,000 operations (inductive load) Mechanical: 50,000,000 operations
ON Delay	15 ms max.
OFF Delay	15 ms max.
No. of Outputs	32 (8 outputs/common, 4 circuits)
Internal Current Consumption	200 mA, 5 VDC max.
Weight	600 grams max.
Circuit Configuration	
Terminal Connections	
Dimensions	C-shape

TTL Output Unit

Item	C500-OD501CN
Max. Switching Capacity	5 VDC \pm 10% 35 mA/point
Leakage Current	0.1 mA max.
Residual Voltage	0.4 V max.
ON Delay	0.2 ms max.
OFF Delay	0.3 ms max.
No. of Outputs	32 (8 outputs/common, 4 circuits)
Internal Current Consumption	250 mA, 5 VDC max.
Fuse Capacity	Not provided
Power for External Supply	32 mA, 5 VDC \pm 10% min.
Weight	450 grams max.
Circuit Configuration	
Terminal Connections	<p>Because the output data is negative logic, the terminal output goes low when the output bit is ON (1).</p>
Dimensions	E-shape

DC Input/Transistor Output Unit

C500-MD211CN			
Output (CNI, word n)		Input (CNII, word n+1)	
Max. Switching Capacity	12 to 24 VDC $+10\%$ / -15% , 0.3 A (but, 2.4 A/common, 4.8 A/Unit)	Input Voltage	12 to 24 VDC $+10\%$ / -15%
Leakage Current	0.1 mA max.	Input Impedance	2.2
Residual Voltage	1.5 V max.	Input Current	10 mA typical (at 24 VDC)
Fuses	1 per circuit, 2 total (Cannot be changed by user.)	ON Voltage	10.2 VDC min.
Power for External Supply	80 mA, 12 to 24 VDC $\pm 10\%$ max.	OFF Voltage	3.0 VDC max.
ON Delay	0.2 ms max.	ON Delay	1.5 ms max.
OFF Delay	0.3 ms max.	OFF Delay	1.5 ms max.
No. of Outputs	16 (8 outputs/common, 2 circuits)	No. of Inputs	16 (8 inputs/common, 2 circuits)
Internal Current Consumption	260 mA, 5 VDC max.		
Weight	520 grams max.		
Circuit Configuration			
Terminal Connections			
	<p>(Terminal) To common load</p>		<p>Note The maximum switching capacity for solderless connectors is 1 A/common.</p>
Dimensions	E-shape		

Dummy I/O Unit

Item	3G2A5-DUM01								
Selection Function	Unit designation: input/output Point designation: 16/32/64 points								
Internal Current Consumption	35 mA, 5 VDC max.								
Power for External Supply	30 mA, 24 VDC \pm 10% min.								
Weight	450 grams max.								
Terminal Connections	<div style="display: flex; align-items: center;"> <table border="1" style="margin-right: 20px;"> <thead> <tr> <th>Point designation</th> <th>Terminal connection</th> </tr> </thead> <tbody> <tr> <td>16 points</td> <td>Open 3,4, and 5</td> </tr> <tr> <td>32 points</td> <td>Short 3 and 4. Open 5.</td> </tr> <tr> <td>64 points</td> <td>Short 4 and 5. Open 3.</td> </tr> </tbody> </table> <div style="text-align: right;"> <p>Short-circuit: input</p> <p>Open: output</p> </div> </div>	Point designation	Terminal connection	16 points	Open 3,4, and 5	32 points	Short 3 and 4. Open 5.	64 points	Short 4 and 5. Open 3.
Point designation	Terminal connection								
16 points	Open 3,4, and 5								
32 points	Short 3 and 4. Open 5.								
64 points	Short 4 and 5. Open 3.								
Dimensions	A-shape								

Note Power is supplied to the Dummy I/O Unit from the 24 VDC output terminal of the Power Supply Unit mounted on the same Rack as the Dummy I/O Unit. Be sure to supply power to the Dummy I/O Unit before supplying power to the CPU. If power is supplied to the Dummy I/O Unit after power is supplied to the CPU, the Dummy I/O Unit is assumed to have only 16 I/O points, and may result in an I/O Verification Error or an I/O Setting Error.

Interrupt Input Unit

Item	3G2A5-ID216																																																																								
Input Voltage	12 to 24 VDC +10%/-15% (nonpolar)																																																																								
Input Impedance	1.5 k																																																																								
Input Current	13 mA typical (at 24 VDC)																																																																								
ON Voltage	10.2 VDC min.																																																																								
OFF Voltage	3.0 VDC max.																																																																								
ON Delay	1 ms max.																																																																								
OFF Delay	1.5 ms max.																																																																								
No. of Inputs	8 (independent commons)																																																																								
Internal Current Consumption	5 VDC 200 mA max.																																																																								
Weight	450 grams max.																																																																								
Circuit Configuration																																																																									
Terminal Connections	<table border="0"> <tr> <td>12 to 24 VDC</td> <td></td> <td>0</td> <td rowspan="2">IN 0</td> </tr> <tr> <td></td> <td></td> <td>1</td> </tr> <tr> <td>12 to 24 VDC</td> <td></td> <td>2</td> <td rowspan="2">IN 1</td> </tr> <tr> <td></td> <td></td> <td>3</td> </tr> <tr> <td>12 to 24 VDC</td> <td></td> <td>4</td> <td rowspan="2">IN 2</td> </tr> <tr> <td></td> <td></td> <td>5</td> </tr> <tr> <td>12 to 24 VDC</td> <td></td> <td>6</td> <td rowspan="2">IN 3</td> </tr> <tr> <td></td> <td></td> <td>7</td> </tr> <tr> <td>12 to 24 VDC</td> <td></td> <td>8</td> <td rowspan="2">IN 4</td> </tr> <tr> <td></td> <td></td> <td>9</td> </tr> <tr> <td>12 to 24 VDC</td> <td></td> <td>10</td> <td rowspan="2">IN 5</td> </tr> <tr> <td></td> <td></td> <td>11</td> </tr> <tr> <td>12 to 24 VDC</td> <td></td> <td>12</td> <td rowspan="2">IN 6</td> </tr> <tr> <td></td> <td></td> <td>13</td> </tr> <tr> <td>12 to 24 VDC</td> <td></td> <td>14</td> <td rowspan="2">IN 7</td> </tr> <tr> <td></td> <td></td> <td>15</td> </tr> <tr> <td></td> <td></td> <td>NC</td> <td>16</td> </tr> <tr> <td></td> <td></td> <td>NC</td> <td>17</td> </tr> <tr> <td></td> <td></td> <td>NC</td> <td>18</td> </tr> <tr> <td></td> <td></td> <td>NC</td> <td>19</td> </tr> </table>	12 to 24 VDC		0	IN 0			1	12 to 24 VDC		2	IN 1			3	12 to 24 VDC		4	IN 2			5	12 to 24 VDC		6	IN 3			7	12 to 24 VDC		8	IN 4			9	12 to 24 VDC		10	IN 5			11	12 to 24 VDC		12	IN 6			13	12 to 24 VDC		14	IN 7			15			NC	16			NC	17			NC	18			NC	19
12 to 24 VDC		0	IN 0																																																																						
		1																																																																							
12 to 24 VDC		2	IN 1																																																																						
		3																																																																							
12 to 24 VDC		4	IN 2																																																																						
		5																																																																							
12 to 24 VDC		6	IN 3																																																																						
		7																																																																							
12 to 24 VDC		8	IN 4																																																																						
		9																																																																							
12 to 24 VDC		10	IN 5																																																																						
		11																																																																							
12 to 24 VDC		12	IN 6																																																																						
		13																																																																							
12 to 24 VDC		14	IN 7																																																																						
		15																																																																							
		NC	16																																																																						
		NC	17																																																																						
		NC	18																																																																						
		NC	19																																																																						
Dimensions	A-shape																																																																								

I/O Power Supply Unit

Item	CV500-IPS01
Input Voltage	100 through 120 VAC/200 through 240 VAC 50/60 Hz
Allowable Input Voltage Range	85 to 132 VAC/170 to 264 VAC
Input Current	160 VA max.
Output Capacity	2 A, 24 VDC
Dimensions	34.5 x 250 x 116 mm (WxHxD)
Weight	700 grams max.

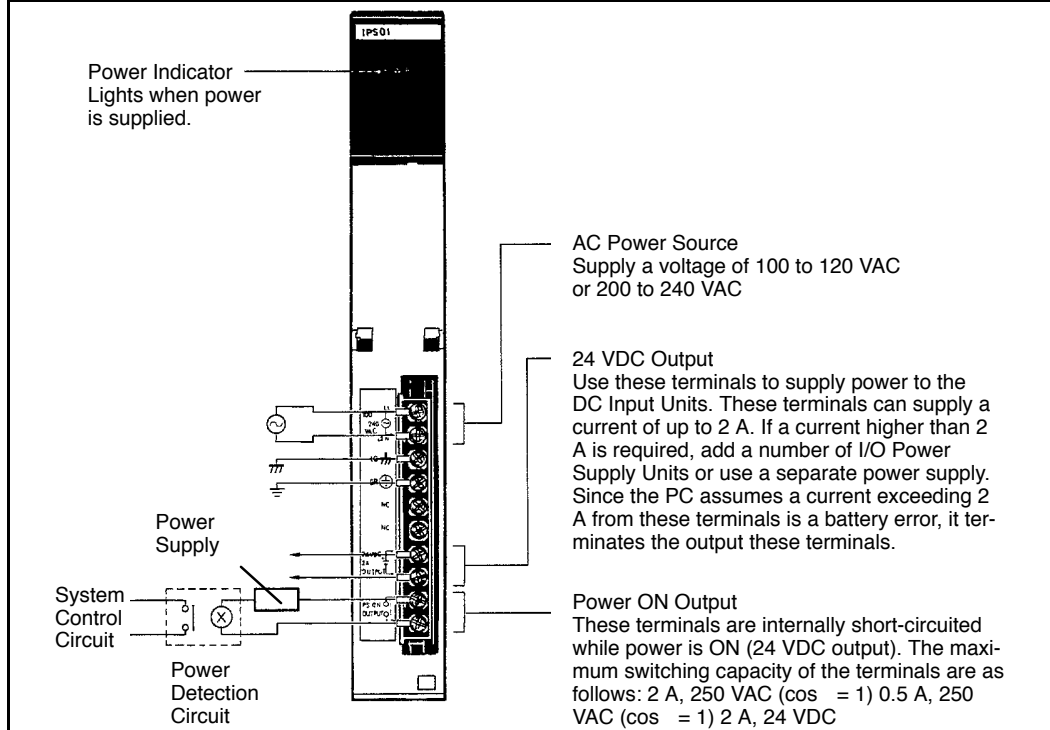

Battery Lifetimes

CPU Battery

The minimum lifetimes of the battery are given below.

Model	Battery life	Memory backup time without power supplied	
		Guaranteed value	Effective value
CV500/CVM1-CPU01-EV2	5 years	9,000 hours (approx. 1 year)	43,000 hours (approx. 5 years)
CV1000/2000, CVM1-CPU21-EV2 without Expansion DM, CVM1-CPU11-EV2		5,600 hours (approx. 0.6 year)	
CV1000/2000, CVM1-CPU21-EV2 with Expansion DM		2,900 hours (approx. 0.3 year)	

Guaranteed value: Memory backup time without power supplied at 55°C.

Effective value: Memory backup time without power supplied at 25°C.

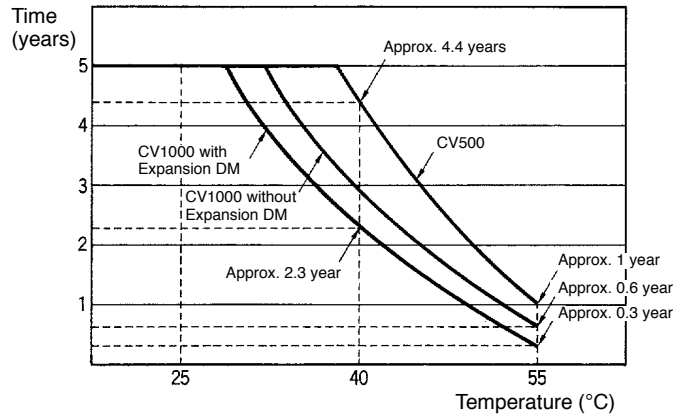

Memory Card Battery

The life of the battery of the Memory Card varies with the Unit, as shown in the following table.

Model	Capacity	Life
HMC-ES641	64 KB	5 years
HMC-ES151	128 KB	3 years
HMC-ES251	256 KB	1 year
HMC-ES551	512 KB	0.5 years

Dimensions

All dimensions are in millimeters unless stated otherwise.

CPU Racks

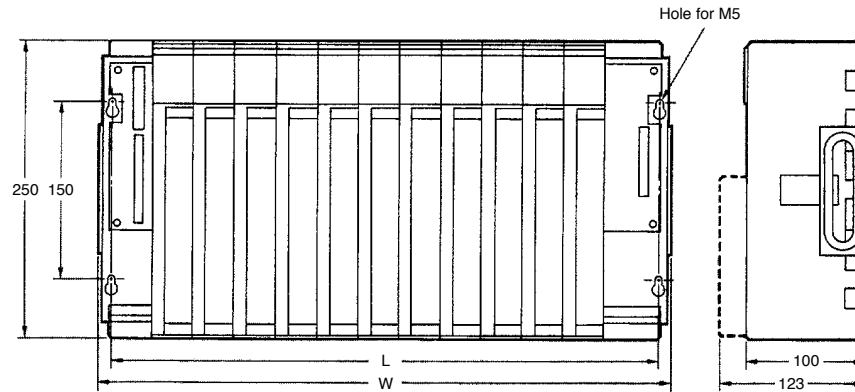

Model	Slots	W	L
CV500-BC101 CVM1-BC103	10	480	465
CV500-BC051 CVM1-BC053	5	306	291
CV500-BC031	3	236	221

Expansion CPU and Expansion I/O Racks

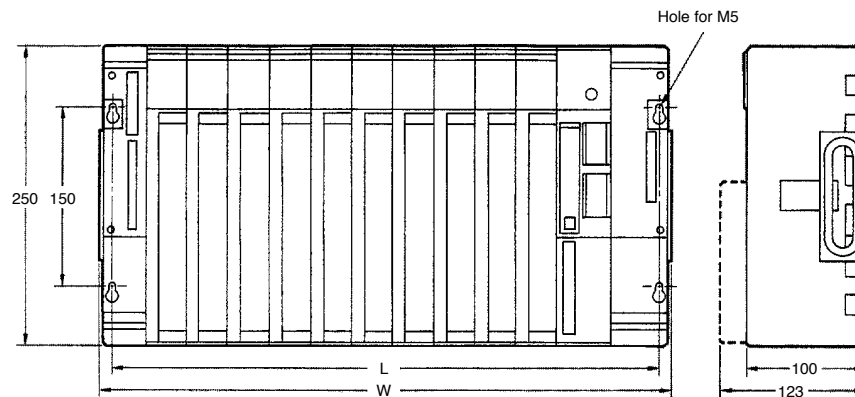

Model	Slots	W	L
CV500-BI111/112 CVM1-BI114	11	480	465
CV500-BI062 CVM1-BI064	6	306	291
CV500-BI042	4	236	221

Backplanes

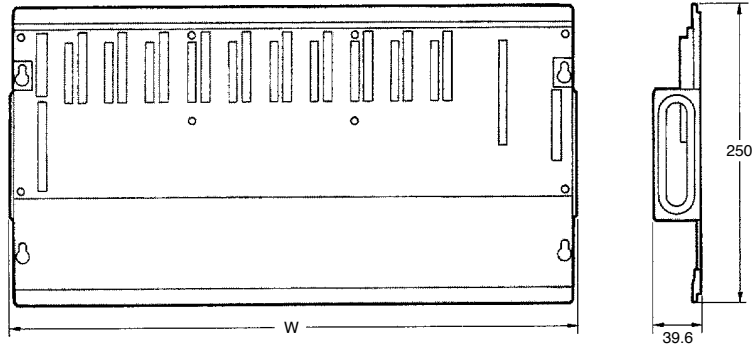

Model	W
CV500-BC101/BI111/BI12 CVM1-BC103/BI114	480
CV500-BC051/BI062 CVM1-BC053/BI064	306
CV500-BC031/BI042	236

CPUs

- CV500-CPU01-EV1 CV1000-CPU01-EV1
- CV2000-CPU01-EV1 CVM1-CPU01-EV2
- CVM1-CPU11-EV2 CVM1-CPU21-EV2

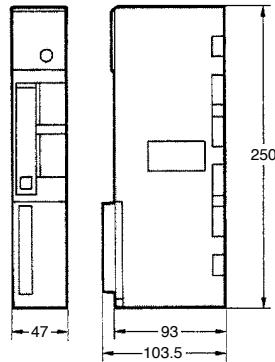

Power Supply Units

- CV500-PS221/PS211
- CVM1-PA208

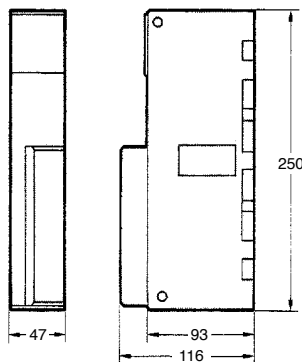

I/O Control Units

CV500-IC101/IC201/IC301

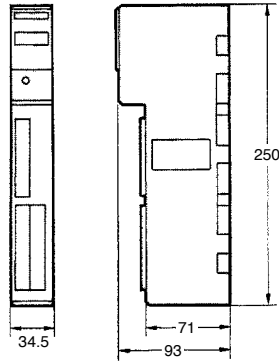

I/O Interface Units

CV500-II101/II201

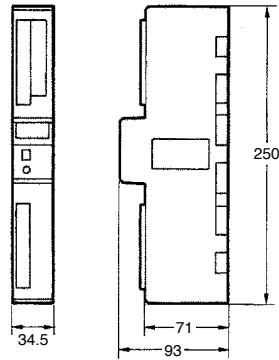

Termination Resistance Unit

CV500-TER01

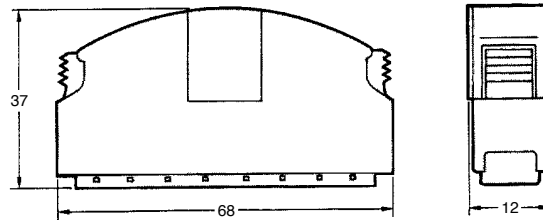

Expansion Data Memory Units

CV500-DM641/DM151/DM251

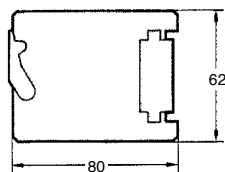

A-shape I/O Units

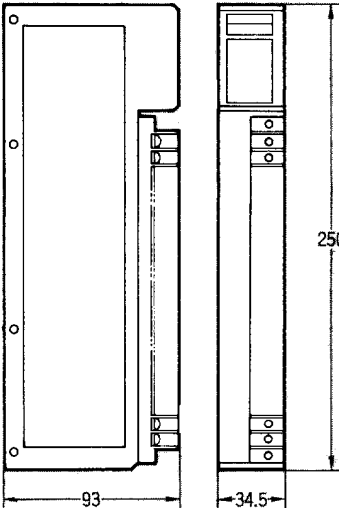

B-shape I/O Units

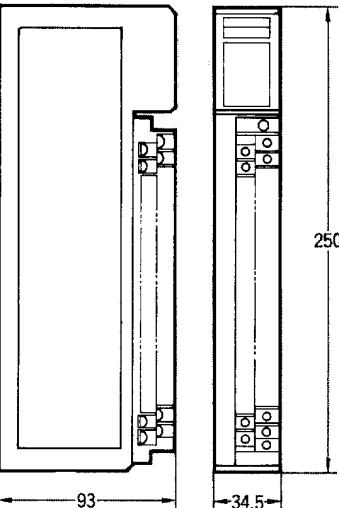

C-shape I/O Units

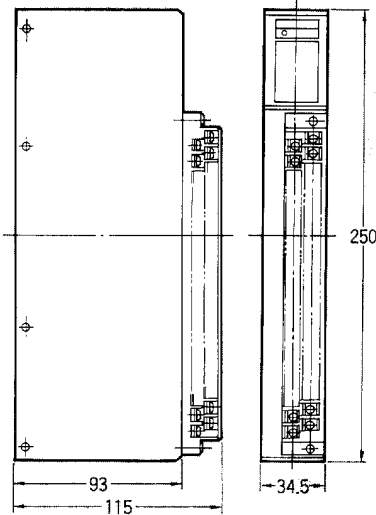

D-shape I/O Units

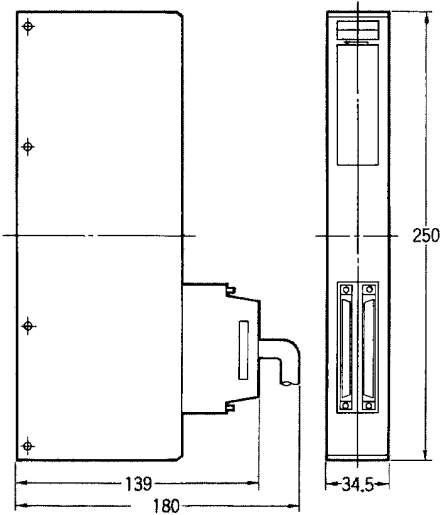

E-shape I/O Units

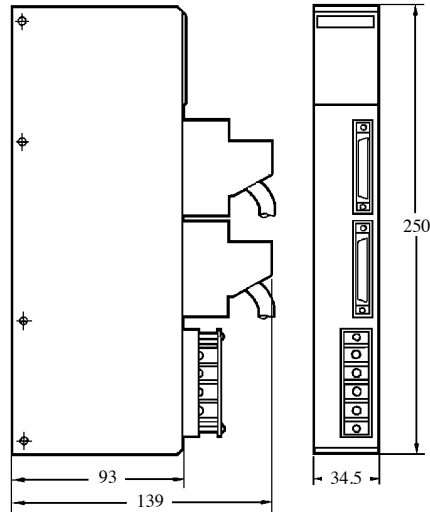

Weights

Model	Weight (gram)
CV500-CPU01-EV1/CVM1-CPU01-EV2	650
CV1000-CPU01-EV1/CV2000-CPU01-EV1 /CVM1-CPU11-EV2/CVM1-CPU21-EV2	700
CV500-PS221/211, PA208	900
CV500-IC101/201	380
CV500-IC301	270
CV500-II101/201	400
CV500-BC101/BI111/BI112, CVM1-BC103/BI114	1,900
CV500-BC051/BI062, CVM1-BC053/BI064	1,300
CV500-BC031/BI042	1,100
CV500-DM641/151/251	40

Connecting Cables

Use an I/O Cable to connect the CPU Rack to an Expansion I/O Rack or to connect an Expansion I/O Rack to another Expansion I/O Rack. If connecting an Expansion CPU Rack to the CPU Rack, use two cables, an I/O Cable and a CPU Bus Cable, to connect the CPU Rack to the Expansion CPU Rack.

Secure the connectors with the locks provided on the connectors to secure the connection between the cable connector and the connectors. If the connectors are not properly connected, errors such as I/O Bus Errors or I/O Setting Errors will occur.

Cable name	Model	Cable length (L)	Weight	Connector dimensions (W x H x D)
CPU Bus Cable (for Expansion CPU Rack)	CV500-CN311	0.3 m	110 g	60 x 42 x 12 mm
	CV500-CN611	0.6 m	150 g	
I/O Cable (for connecting Expansion I/O Rack via I/O Interface Unit)	CV500-CN312	0.3 m	140 g	68 x 45 x 12 mm
	CV500-CN612	0.6 m	180 g	
	CV500-CN122	1 m	240 g	
	CV500-CN222	2 m	380 g	
	CV500-CN132	10 m	1.6 kg	
	CV500-CN332	30 m	4.4 kg	
	CV500-CN532	50 m	7.2 kg	
I/O Cable (for connecting single Expansion I/O Rack via Backplanes)	CV500-CN413	0.4 m	100 g	49 x 42 x 12 mm
	CV500-CN613	0.6 m	120 g	

Note Do not put the Connecting Cables in the same duct with power lines or I/O wiring.

Cable Dimensions

The figures below show the dimensions of the cables.

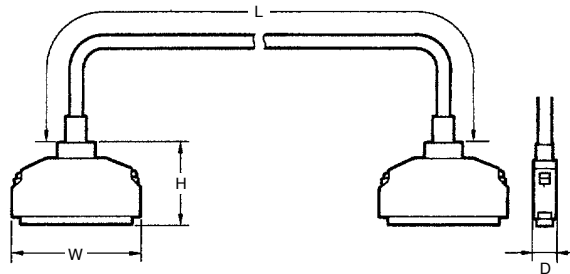

Glossary

address	A number used to identify the location of data or programming instructions in memory or to identify the location of a network or a unit in a network.
advanced instruction	An instruction input with a function code that handles data processing operations within ladder diagrams, as opposed to a basic instruction, which makes up the fundamental portion of a ladder diagram.
AGF	All-glass optical fiber cable; also known as crystal optical fiber cable.
allocation	The process by which the PC assigns certain bits or words in memory for various functions. This includes pairing I/O bits to I/O points on Units.
analog	Something that represents or can process a continuous range of values as opposed to values that can be represented in distinct increments. Something that represents or can process values represented in distinct increments is called digital.
Analog I/O Unit	I/O Units that convert I/O between analog and digital values. An Analog Input Unit converts an analog input to a digital value for processing by the PC. An Analog Output Unit converts a digital value to an analog output.
AND	A logic operation whereby the result is true if and only if both premises are true. In ladder-diagram programming the premises are usually ON/OFF states of bits or the logical combination of such states called execution conditions.
APF	An acronym for all-plastic optical fiber cable.
area	See <i>data area</i> and <i>memory area</i> .
area prefix	A one or two letter prefix used to identify a memory area in the PC. All memory areas except the CIO area require prefixes to identify addresses in them.
ASCII	Short for American Standard Code for Information Interchange. ASCII is used to code characters for output to printers and other external devices.
asynchronous execution	Execution of programs and servicing operations in which program execution and servicing are not synchronized with each other.
Auxiliary Area	A PC data area allocated to flags and control bits.
auxiliary bit	A bit in the Auxiliary Area.
Backplane	A base to which Units are mounted to form a Rack. Backplanes provide a series of connectors for these Units along with buses to connect them to the CPU and other Units and wiring to connect them to the Power Supply Unit. Backplanes also provide connectors used to connect them to other Backplanes.
back-up	A copy made of existing data to ensure that the data will not be lost even if the original data is corrupted or erased.
BASIC	A common programming language. BASIC Units are programmed in BASIC.
basic instruction	A fundamental instruction used in a ladder diagram. See <i>advanced instruction</i> .

BASIC Unit	A CPU Bus Unit used to run programs in BASIC.
baud rate	The data transmission speed between two devices in a system measured in bits per second.
BCD	Short for binary-coded decimal.
binary	A number system where all numbers are expressed in base 2, i.e., numbers are written using only 0's and 1's. Each group of four binary bits is equivalent to one hexadecimal digit. Binary data in memory is thus often expressed in hexadecimal for convenience.
binary-coded decimal	A system used to represent numbers so that every four binary bits is numerically equivalent to one decimal digit.
bit	The smallest piece of information that can be represented on a computer. A bit has the value of either zero or one, corresponding to the electrical signals ON and OFF. A bit represents one binary digit. Some bits at particular addresses are allocated to special purposes, such as holding the status of input from external devices, while other bits are available for general use in programming.
bit address	The location in memory where a bit of data is stored. A bit address specifies the data area and word that is being addressed as well as the number of the bit within the word.
branch line	A communications line leading from a Link Adapter to any Link Unit not designated as a terminator in a Link System. See <i>main line</i> .
buffer	A temporary storage space for data in a computerized device.
building-block PC	A PC that is constructed from individual components, or "building blocks." With building-block PCs, there is no one Unit that is independently identifiable as a PC. The PC is rather a functional assembly of Units.
bus	A communications path used to pass data between any of the Units connected to it.
bus link	A data link that passed data between two Units across a bus.
byte	A unit of data equivalent to 8 bits, i.e., half a word.
central processing unit	A device that is capable of storing programs and data, and executing the instructions contained in the programs. In a PC System, the central processing unit executes the program, processes I/O signals, communicates with external devices, etc.
channel	See <i>word</i> .
character code	A numeric (usually binary) code used to represent an alphanumeric character.
checksum	A sum transmitted with a data pack in communications. The checksum can be recalculated from the received data to confirm that the data in the transmission has not been corrupted.
CIO Area	A memory area used to control I/O and to store and manipulate data. CIO Area addresses do not require prefixes.
communications cable	Cable used to transfer data between components of a control system and conforming to the RS-232C or RS-422 standards.

constant	An input for an operand in which the actual numeric value is specified. Constants can be input for certain operands in place of memory area addresses. Some operands must be input as constants.
control bit	A bit in a memory area that is set either through the program or via a Programming Device to achieve a specific purpose, e.g., a Restart Bit is turned ON and OFF to restart a Unit.
control signal	A signal sent from the PC to effect the operation of the controlled system.
Control System	All of the hardware and software components used to control other devices. A Control System includes the PC System, the PC programs, and all I/O devices that are used to control or obtain feedback from the controlled system.
controlled system	The devices that are being controlled by a PC System.
Converting Link Adapter	A Link Adapter used to convert between different types of optical fiber cable, different types of wire cable, or between optical fiber cable and wire cable. Such conversion is necessary to connect Units that use different forms of communication.
CPU	See <i>central processing unit</i> .
CPU Backplane	A Backplane used to create a CPU Rack.
CPU Bus Unit	A special Unit used with CV-series PCs that mounts to the CPU bus. This connection to the CPU bus enables special data links, data transfers, and processing.
CPU Rack	The main Rack in a building-block PC, the CPU Rack contains the CPU, a Power Supply, and other Units. The CPU Rack, along with the Expansion CPU Rack, provides both an I/O bus and a CPU bus.
crystal optical fiber cable	See <i>AGF</i> .
C-series PC	Any of the following PCs: C2000H, C1000H, C500, C200H, C40H, C28H, C20H, C60K, C60P, C40K, C40P, C28K, C28P, C20K, C20P, C120, or C20.
CV Support Software	A programming package run on an IBM PC/AT or compatible to serve as a Programming Device for CV-series PCs.
CV-series PC	Any of the following PCs: CV500, CV1000, CV2000, or CVM1
CVSS	See <i>CV Support Software</i> .
cycle	One unit of processing performed by the CPU, including SFC/ladder program execution, peripheral servicing, I/O refreshing, etc. The cycle is called the scan with C-series PCs.
cycle time	The time required to complete one cycle of CPU processing.
data area	An area in the PC's memory that is designed to hold a specific type of data.
data link	An automatic data transmission operation that allows PCs or Units within PC to pass data back and forth via common data areas.
data register	A storage location in memory used to hold data. In CV-series PCs, data registers are used with or without index registers to hold data used in indirect addressing.

data transfer	Moving data from one memory location to another, either within the same device or between different devices connected via a communications line or network.
debug	A process by which a draft program is corrected until it operates as intended. Debugging includes both the removal of syntax errors, as well as the fine-tuning of timing and coordination of control operations.
decimal	A number system where numbers are expressed to the base 10. In a PC all data is ultimately stored in binary form, four binary bits are often used to represent one decimal digit, via a system called binary-coded decimal.
decrement	Decreasing a numeric value, usually by 1.
default	A value automatically set by the PC when the user does not specifically set another value. Many devices will assume such default conditions upon the application of power.
destination	The location where an instruction places the data on which it is operating, as opposed to the location from which data is taken for use in the instruction. The location from which data is taken is called the source.
digit	A unit of storage in memory that consists of four bits.
DIN track	A rail designed to fit into grooves on various devices to allow the devices to be quickly and easily mounted to it.
DIP switch	Dual in-line package switch, an array of pins in a signal package that is mounted to a circuit board and is used to set operating parameters.
distributed control	A automation concept in which control of each portion of an automated system is located near the devices actually being controlled, i.e., control is decentralized and 'distributed' over the system. Distributed control is a concept basic to PC Systems.
DM Area	A data area used to hold only word data. Words in the DM area cannot be accessed bit by bit.
DM word	A word in the DM Area.
downloading	The process of transferring a program or data from a higher-level or host computer to a lower-level or slave computer. If a Programming Device is involved, the Programming Device is considered the host computer.
Dummy I/O Unit	An I/O Unit that has no functional capabilities but that can be mounted to a slot on a Rack so that words can be allocated to that slot. Dummy I/O Units can be used to avoid changing operand addresses in programs by reserving words for a slot for future use or by filling a slot vacated by a Unit to which words have already been allocated.
EEPROM	Electrically erasable programmable read-only memory; a type of ROM in which stored data can be erased and reprogrammed. This is accomplished using a special control lead connected to the EEPROM chip and can be done without having to remove the EEPROM chip from the device in which it is mounted.
electrical noise	Random variations of one or more electrical characteristics such as voltage, current, and data, which might interfere with the normal operation of a device.
EM Area	Extended Data Memory Area; an area that can be optionally added to certain PCs to enable greater data storage. Functionally, the EM Area operates like the

	DM Area. Area addresses are prefixed with E and only words can be accessed. The EM Area is separated into multiple banks.
EM card	A card mounted inside certain PCs to added an EM Area.
EPROM	Erasable programmable read-only memory; a type of ROM in which stored data can be erased, by ultraviolet light or other means, and reprogrammed.
error code	A numeric code generated to indicate that an error exists, and something about the nature of the error. Some error codes are generated by the system; others are defined in the program by the operator.
event processing	Processing that is performed in response to an event, e.g., an interrupt signal.
Expansion CPU Backplane	A Backplane used to create an Expansion CPU Rack.
Expansion CPU Rack	A Rack connected to the CPU Rack to increase the virtual size of the CPU Rack. Units that may be mounted to the CPU Backplane may also be mounted to the Expansion CPU Backplane.
Expansion Data Memory Unit	A card mounted inside certain PCs to added an EM Area.
Expansion I/O Backplane	A Backplane used to create an Expansion I/O Rack.
Expansion I/O Rack	A Rack used to increase the I/O capacity of a PC. In CV-Series PC, either one Expansion I/O Rack can be connected directly to the CPU or Expansion CPU Rack or multiple Expansion I/O Racks can be connected by using an I/O Control and I/O Interface Units.
FA	Factory automation.
factory computer	A general-purpose computer, usually quite similar to a business computer, that is used in automated factory control.
fatal error	An error that stops PC operation and requires correction before operation can continue.
FINS	See <i>CV-mode</i> .
flag	A dedicated bit in memory that is set by the system to indicate some type of operating status. Some flags, such as the carry flag, can also be set by the operator or via the program.
force reset	The process of forcibly turning OFF a bit via a programming device. Bits are usually turned OFF as a result of program execution.
force set	The process of forcibly turning ON a bit via a programming device. Bits are usually turned ON as a result of program execution.
frame checksum	The results of exclusive ORing all data within a specified calculation range. The frame checksum can be calculated on both the sending and receiving end of a data transfer to confirm that data was transmitted correctly.
GPC	An acronym for Graphic Programming Console.
Graphic Programming Console	A programming device with advanced programming and debugging capabilities to facilitate PC operation. A Graphic Programming Console is provided with a

large display onto which ladder-diagram programs can be written directly in ladder-diagram symbols for input into the PC without conversion to mnemonic form.

hexadecimal	A number system where all numbers are expressed to the base 16. In a PC all data is ultimately stored in binary form, however, displays and inputs on Programming Devices are often expressed in hexadecimal to simplify operation. Each group of four binary bits is numerically equivalent to one hexadecimal digit.
host interface	An interface that allows communications with a host computer.
Host Link System	A system with one or more host computers connected to one or more PCs via Host Link Units or host interfaces so that the host computer can be used to transfer data to and from the PC(s). Host Link Systems enable centralized management and control of PC Systems.
Host Link Unit	An interface used to connect a C-series PC to a host computer in a Host Link System.
H-PCF cable	An acronym for hard plastic-clad optical fiber cable.
I/O allocation	The process by which the PC assigns certain bits in memory for various functions. This includes pairing I/O bits to I/O points on Units.
I/O Block	Either an Input Block or an Output Block. I/O Blocks provide mounting positions for replaceable relays.
I/O Control Unit	A Unit mounted to the CPU Rack to monitor and control I/O points on Expansion CPU Racks or Expansion I/O Racks.
I/O delay	The delay in time from when a signal is sent to an output to when the status of the output is actually in effect or the delay in time from when the status of an input changes until the signal indicating the change in the status is received.
I/O device	A device connected to the I/O terminals on I/O Units, Special I/O Units, etc. I/O devices may be either part of the Control System, if they function to help control other devices, or they may be part of the controlled system.
I/O Interface Unit	A Unit mounted to an Expansion CPU Rack or Expansion I/O Rack to interface the Rack to the CPU Rack.
I/O point	The place at which an input signal enters the PC System, or at which an output signal leaves the PC System. In physical terms, I/O points correspond to terminals or connector pins on a Unit; in terms of programming, an I/O points correspond to I/O bits in the IR area.
I/O refreshing	The process of updating output status sent to external devices so that it agrees with the status of output bits held in memory and of updating input bits in memory so that they agree with the status of inputs from external devices.
I/O response time	The time required for an output signal to be sent from the PC in response to an input signal received from an external device.
I/O Terminal	A Remote I/O Unit connected in a Wired Remote I/O System to provide a limited number of I/O points at one location. There are several types of I/O Terminals.
I/O Unit	The most basic type of Unit mounted to a Backplane. I/O Units include Input Units and Output Units, each of which is available in a range of specifications. I/O Units do not include Special I/O Units, Link Units, etc.

I/O verification error	A error generated by a disagreement between the Units registered in the I/O table and the Units actually mounted to the PC.
I/O word	A word in the CIO area that is allocated to a Unit in the PC System and is used to hold I/O status for that Unit.
IBM PC/AT or compatible	A computer that has similar architecture to, that is logically compatible with, and that can run software designed for an IBM PC/AT computer.
initialize	Part of the startup process whereby some memory areas are cleared, system setup is checked, and default values are set.
input	The signal coming from an external device into the PC. The term input is often used abstractly or collectively to refer to incoming signals.
input bit	A bit in the CIO area that is allocated to hold the status of an input.
Input Block	A Unit used in combination with a Remote Interface to create an I/O Terminal. An Input Block provides mounting positions for replaceable relays. Each relay can be selected according to specific input requirements.
input device	An external device that sends signals into the PC System.
input point	The point at which an input enters the PC System. Input points correspond physically to terminals or connector pins.
input signal	A change in the status of a connection entering the PC. Generally an input signal is said to exist when, for example, a connection point goes from low to high voltage or from a nonconductive to a conductive state.
Input Terminal	An I/O Terminal that provides input points.
instruction	A direction given in the program that tells the PC of the action to be carried out, and the data to be used in carrying out the action. Instructions can be used to simply turn a bit ON or OFF, or they can perform much more complex actions, such as converting and/or transferring large blocks of data.
interface	An interface is the conceptual boundary between systems or devices and usually involves changes in the way the communicated data is represented. Interface devices such as NSBs perform operations like changing the coding, format, or speed of the data.
interrupt (signal)	A signal that stops normal program execution and causes a subroutine to be run or other processing to take place.
Interrupt Input Unit	A Rack-mounting Unit used to input external interrupts into a PC System.
IOIF	An acronym for I/O Interface Unit.
IOM (Area)	A collective memory area containing all of the memory areas that can be accessed by bit, including timer and counter Completion Flags. The IOM Area includes all memory area memory addresses between 0000 and 0FFF.
JIS	An acronym for Japanese Industrial Standards.
jump	A type of programming where execution moves directly from one point in a program to another, without sequentially executing any instructions in between.

Jumps in ladder diagrams are usually conditional on an execution condition; jumps in SFC programs are conditional on the step status and transition condition status before the jump.

least-significant (bit/word)	See <i>rightmost (bit/word)</i> .
LED	Acronym for light-emitting diode; a device used as for indicators or displays.
leftmost (bit/word)	The highest numbered bits of a group of bits, generally of an entire word, or the highest numbered words of a group of words. These bits/words are often called most-significant bits/words.
link	A hardware or software connection formed between two Units. "Link" can refer either to a part of the physical connection between two Units or a software connection created to data existing at another location (i.e., data links).
Link Adapter	A Unit used to connect communications lines, either to branch the lines or to convert between different types of cable. There are two types of Link Adapter: Branching Link Adapters and Converting Link Adapters.
Link System	A system used to connect remote I/O or to connect multiple PCs in a network. Link Systems include the following: SYSMAC BUS Remote I/O Systems, SYSMAC BUS/2 Remote I/O Systems, SYSMAC LINK Systems, Host Link Systems, and SYSMAC NET Link Systems.
Link Unit	Any of the Units used to connect a PC to a Link System. These include Remote I/O Units, SYSMAC LINK Units, and SYSMAC NET Link Units.
linkable slot	A slot on either a Backplane to which a Link Unit can be mounted. Backplanes differ in the slots to which Link Units can be mounted.
load	The processes of copying data either from an external device or from a storage area to an active portion of the system such as a display buffer. Also, an output device connected to the PC is called a load.
main line	In a Link System connected through Branching Link Adapters, the communications cable that runs from the Unit at each end of the System through the Link Adapters.
MCR Unit	Magnetic Card Reader Unit.
megabyte	A unit of storage equal to one million bytes.
memory area	Any of the areas in the PC used to hold data or programs.
most-significant (bit/word)	See <i>leftmost (bit/word)</i> .
nesting	Programming one loop within another loop, programming a call to a subroutine within another subroutine, or programming an IF–ELSE programming section within another IF–ELSE section.
Network Service Board	A device with an interface to connect devices other than PCs to a SYSMAC NET Link System.
Network Service Unit	A Unit that provides two interfaces to connect peripheral devices to a SYSMAC NET Link System.
noise interference	Disturbances in signals caused by electrical noise.

nonfatal error	A hardware or software error that produces a warning but does not stop the PC from operating.
NOT	A logic operation which inverts the status of the operand. For example, AND NOT indicates an AND operation with the opposite of the actual status of the operand bit.
octal	A number system where all numbers are expressed in base 8, i.e., numbers are written using only numerals 0 through 7.
OFF	The status of an input or output when a signal is said not to be present. The OFF state is generally represented by a low voltage or by non-conductivity, but can be defined as the opposite of either.
OFF delay	The delay between the time when a signal is switched OFF (e.g., by an input device or PC) and the time when the signal reaches a state readable as an OFF signal (i.e., as no signal) by a receiving party (e.g., output device or PC).
offset	A positive or negative value added to a base value such as an address to specify a desired value.
ON	The status of an input or output when a signal is said to be present. The ON state is generally represented by a high voltage or by conductivity, but can be defined as the opposite of either.
ON delay	The delay between the time when an ON signal is initiated (e.g., by an input device or PC) and the time when the signal reaches a state readable as an ON signal by a receiving party (e.g., output device or PC).
on-line removal	Removing a Rack-mounted Unit for replacement or maintenance during PC operation.
operand	The values designated as the data to be used for an instruction. An operand can be input as a constant expressing the actual numeric value to be used or as an address to express the location in memory of the data to be used.
operating error	An error that occurs during actual PC operation as opposed to an initialization error, which occurs before actual operations can begin.
optical connector	A connector designed to be connected to an optical fiber cable.
optical fiber cable	Cable made from light conducting filaments used to transmit signals.
OR	A logic operation whereby the result is true if either of two premises is true, or if both are true. In ladder-diagram programming the premises are usually ON/OFF states of bits or the logical combination of such states called execution conditions.
output	The signal sent from the PC to an external device. The term output is often used abstractly or collectively to refer to outgoing signals.
Output Block	A Unit used in combination with a Remote Interface to create an I/O Terminal. An Output Block provides mounting positions for replaceable relays. Each relay can be selected according to specific output requirements.
output device	An external device that receives signals from the PC System.
output point	The point at which an output leaves the PC System. Output points correspond physically to terminals or connector pins.

output signal	A signal being sent to an external device. Generally an output signal is said to exist when, for example, a connection point goes from low to high voltage or from a nonconductive to a conductive state.
Output Terminal	An I/O Terminal that provides output points.
overflow	The state where the capacity of a data storage location has been exceeded.
overwrite	Changing the content of a memory location so that the previous content is lost.
parity	Adjustment of the number of ON bits in a word or other unit of data so that the total is always an even number or always an odd number. Parity is generally used to check the accuracy of data after being transmitted by confirming that the number of ON bits is still even or still odd.
parity check	Checking parity to ensure that transmitted data has not been corrupted.
PC	An acronym for Programmable Controller.
PC configuration	The arrangement and interconnections of the Units that are put together to form a functional PC.
PC System	With building-block PCs, all of the Racks and independent Units connected directly to them up to, but not including the I/O devices. The boundaries of a PC System are the PC and the program in its CPU at the upper end; and the I/O Units, Special I/O Units, Optical I/O Units, Remote Terminals, etc., at the lower end.
PCB	An acronym for printed circuit board.
PCF	An acronym for plastic-clad optical fiber cable.
PC Setup	A group of operating parameters set in the PC from a Programming Device to control PC operation.
Peripheral Device	Devices connected to a PC System to aid in system operation. Peripheral devices include printers, programming devices, external storage media, etc.
peripheral servicing	Processing signals to and from peripheral devices, including refreshing, communications processing, interrupts, etc.
PID Unit	A Unit designed for PID control.
port	A connector on a PC or computer that serves as a connection to an external device.
Power Supply Unit	A Unit that mounts to a Backplane in a Rack PC. It provides power at the voltage required by the other Units on the Rack.
present value	The current value registered in a device at any instant during its operation. Present value is abbreviated as PV. The use of this term is generally restricted to timers and counters.
printed circuit board	A board onto which electrical circuits are printed for mounting into a computer or electrical device.
Printer Interface Unit	A Unit used to interface a printer so that ladder diagrams and other data can be printed out.

Programmable Controller	A computerized device that can accept inputs from external devices and generate outputs to external devices according to a program held in memory. Programmable Controllers are used to automate control of external devices. Although single-unit Programmable Controllers are available, building-block Programmable Controllers are constructed from separate components. Such Programmable Controllers are formed only when enough of these separate components are assembled to form a functional assembly, i.e., there is no one individual Unit called a PC.
Programming Console	The simplest form of programming device available for a PC. Programming Consoles are available both as hand-held models and as CPU-mounting models.
Programming Device	A Peripheral Device used to input a program into a PC or to alter or monitor a program already held in the PC. There are dedicated programming devices, such as Programming Consoles, and there are non-dedicated devices, such as a host computer.
PROM	Programmable read-only memory; a type of ROM into which the program or data may be written after manufacture, by a customer, but which is fixed from that time on.
PROM Writer	A peripheral device used to write programs and other data into a ROM for permanent storage and application.
prompt	A message or symbol that appears on a display to request input from the operator.
protocol	The parameters and procedures that are standardized to enable two devices to communicate or to enable a programmer or operator to communicate with a device.
PV	See <i>present value</i> .
Rack	An assembly that forms a functional unit in a Rack PC System. A Rack consists of a Backplane and the Units mounted to it. These Units include the Power Supply, CPU, and I/O Units. Racks include CPU Racks, Expansion I/O Racks, and I/O Racks. The CPU Rack is the Rack with the CPU mounted to it. An Expansion I/O Rack is an additional Rack that holds extra I/O Units. An I/O Rack is used in the C2000H Duplex System, because there is no room for any I/O Units on the CPU Rack in this System.
rack number	A number assigned to a Rack according to the order that it is connected to the CPU Rack, with the CPU Rack generally being rack number 0.
Rack PC	A PC that is composed of Units mounted to one or more Racks. This configuration is the most flexible, and most large PCs are Rack PCs. A Rack PC is the opposite of a Package-type PC, which has all of the basic I/O, storage, and control functions built into a single package.
RAM	Random access memory; a data storage media. RAM will not retain data when power is disconnected.
RAS	An acronym for reliability, assurance, safety.
refresh	The process of updating output status sent to external devices so that it agrees with the status of output bits held in memory and of updating input bits in memory so that they agree with the status of inputs from external devices.

relay-based control	The forerunner of PCs. In relay-based control, groups of relays are interconnected to form control circuits. In a PC, these are replaced by programmable circuits.
reserved bit	A bit that is not available for user application.
reserved word	A word in memory that is reserved for a special purpose and cannot be accessed by the user.
reset	The process of turning a bit or signal OFF or of changing the present value of a timer or counter to its set value or to zero.
Restart Bit	A bit used to restart a Unit mounted to a PC.
restart continuation	A process which allows memory and program execution status to be maintained so that PC operation can be restarted from the state it was in when operation was stopped by a power interruption.
retrieve	The processes of copying data either from an external device or from a storage area to an active portion of the system such as a display buffer. Also, an output device connected to the PC is called a load.
retry	The process whereby a device will re-transmit data which has resulted in an error message from the receiving device.
rightmost (bit/word)	The lowest numbered bits of a group of bits, generally of an entire word, or the lowest numbered words of a group of words. These bits/words are often called least-significant bits/words.
rising edge	The point where a signal actually changes from an OFF to an ON status.
ROM	Read only memory; a type of digital storage that cannot be written to. A ROM chip is manufactured with its program or data already stored in it and can never be changed. However, the program or data can be read as many times as desired.
RS-232C interface	An industry standard for serial communications.
RS-422 interface	An industry standard for serial communications.
scan	The process used to execute a ladder-diagram program. The program is examined sequentially from start to finish and each instruction is executed in turn based on execution conditions. The scan also includes peripheral processing, I/O refreshing, etc. The scan is called the cycle with CV-series PCs.
scan time	The time required for a single scan of a ladder-diagram program.
self diagnosis	A process whereby the system checks its own operation and generates a warning or error if an abnormality is discovered.
series	A wiring method in which Units are wired consecutively in a string. In Link Systems wired through Link Adapters, the Units are still functionally wired in series, even though Units are placed on branch lines.
servicing	The process whereby the PC provides data to or receives data from external devices or remote I/O Units, or otherwise handles data transactions for Link Systems.

set	The process of turning a bit or signal ON.
set value	The value from which a decrementing counter starts counting down or to which an incrementing counter counts up (i.e., the maximum count), or the time from which or for which a timer starts timing. Set value is abbreviated SV.
slot	A position on a Rack (Backplane) to which a Unit can be mounted.
software error	An error that originates in a software program.
software protect	A means of protecting data from being changed that uses software as opposed to a physical switch or other hardware setting.
software switch	See <i>memory switch</i> .
Special I/O Unit	A Unit that is designed for a specific purpose. Special I/O Units include Position Control Units, High-speed Counter Units, Analog I/O Units, etc.
SRAM	Static random access memory; a data storage media.
subroutine	A group of instructions placed separate from the main program and executed only when called from the main program or activated by an interrupt.
SV	Abbreviation for set value.
switching capacity	The maximum voltage/current that a relay can safely switch on and off.
synchronous execution	Execution of programs and servicing operations in which program execution and servicing are synchronized so that all servicing operations are executed each time the programs are executed.
syntax	The form of a program statement (as opposed to its meaning). For example, the two statements, <code>LET A=B+B</code> and <code>LET A=B*2</code> use different syntaxes, but have the same meaning.
syntax error	An error in the way in which a program is written. Syntax errors can include 'spelling' mistakes (i.e., a function code that does not exist), mistakes in specifying operands within acceptable parameters (e.g., specifying read-only bits as a destination), and mistakes in actual application of instructions (e.g., a call to a subroutine that does not exist).
system configuration	The arrangement in which Units in a System are connected. This term refers to the conceptual arrangement and wiring together of all the devices needed to comprise the System. In OMRON terminology, system configuration is used to describe the arrangement and connection of the Units comprising a Control System that includes one or more PCs.
system error	An error generated by the system, as opposed to one resulting from execution of an instruction designed to generate an error.
system error message	An error message generated by the system, as opposed to one resulting from execution of an instruction designed to generate a message.
terminator	The code comprising an asterisk and a carriage return (* CR) which indicates the end of a block of data in communications between devices. Frames within a multi-frame block are separated by delimiters. Also a Unit in a Link System designated as the last Unit on the communications line.

timer	A location in memory accessed through a TC bit and used to time down from the timer's set value. Timers are turned ON and reset according to their execution conditions.
TR Area	A data area used to store execution conditions so that they can be reloaded later for use with other instructions.
TR bit	A bit in the TR Area.
transfer	The process of moving data from one location to another within the PC, or between the PC and external devices. When data is transferred, generally a copy of the data is sent to the destination, i.e., the content of the source of the transfer is not changed.
transmission distance	The distance that a signal can be transmitted.
UM area	The memory area used to hold the active program, i.e., the program that is being currently executed.
Unit	In OMRON PC terminology, the word Unit is capitalized to indicate any product sold for a PC System. Though most of the names of these products end with the word Unit, not all do, e.g., a Remote Terminal is referred to in a collective sense as a Unit. Context generally makes any limitations of this word clear.
unit address	A number used to control network communications. Unit addresses are computed for Units in various ways, e.g., 10 hex is added to the unit number to determine the unit address for a CPU Bus Unit.
unit number	A number assigned to some Link Units, Special I/O Units, and CPU Bus Units to facilitate identification when assigning words or other operating parameters.
uploading	The process of transferring a program or data from a lower-level or slave computer to a higher-level or host computer. If a Programming Device is involved, the Programming Device is considered the host computer.
watchdog timer	A timer within the system that ensures that the scan time stays within specified limits. When limits are reached, either warnings are given or PC operation is stopped depending on the particular limit that is reached.
WDT	See <i>watchdog timer</i> .
wire communications	A communications method in which signals are sent over wire cable. Although noise resistance and transmission distance can sometimes be a problem with wire communications, they are still the cheapest and the most common, and perfectly adequate for many applications.
word	A unit of data storage in memory that consists of 16 bits. All data areas consists of words. Some data areas can be accessed only by words; others, by either words or bits.
word address	The location in memory where a word of data is stored. A word address must specify (sometimes by default) the data area and the number of the word that is being addressed.
word allocation	The process of assigning I/O words and bits in memory to I/O Units and terminals in a PC System to create an I/O Table.
work area	A part of memory containing work words/bits.

work bit	A bit in a work word.
work word	A word that can be used for data calculation or other manipulation in programming, i.e., a 'work space' in memory. A large portion of the IR area is always reserved for work words. Parts of other areas not required for special purposes may also be used as work words.
write protect switch	A switch used to write-protect the contents of a storage device, e.g., a floppy disk. If the hole on the upper left of a floppy disk is open, the information on this floppy disk cannot be altered.
write-protect	A state in which the contents of a storage device can be read but cannot be altered.

Index

A–B

- AC Inputs,
- alarm outputs,
- ambient temperature,
- ASCII,
- assembly,
 - Expansion Data Memory Unit,
 - Memory Cards,
 - mounting units,
- assembly tool,
- BASIC Unit,
- bleeder resistors,

C

- C500 Expansion I/O Rack, system configuration,
- cables
 - All Plastic Optical-Fiber: APF,
 - Plastic-clad Optical-Fiber: PCF,
- common, number of points turned ON simultaneously,
- connecting, cables,
- control systems
 - See also* system overview,
- cooling, fan,
- CPU,
 - battery,
 - replacement,
 - front panel nomenclature,
 - indicators,
 - protect keyswitch,
 - Memory Cards,
 - Power Supply Units,
 - Racks,
 - settings, DIP switch,
- CPU Racks,
 - connecting to another Backplane,
- CPUs
 - comparison,
 - improved specifications,
 - new,
- current consumption,
- CV Support Software,
- CVSS,
 - baud rate,
- cycle time,

D

- DC Input Units,
- dimensions
 - A-shape I/O Units,
 - B-shape I/O Units,
 - Backplanes,
 - C-shape I/O Units,
 - cable,
 - CPU Racks,
 - CPUs,
 - D-shape I/O Units,
 - E-shape I/O Units,
 - Expansion CPU Racks,
 - Expansion Data Memory Units,
 - Expansion I/O Racks,
 - I/O Control Units,
 - I/O Interface Units,
 - Power Supply Units,
 - Termination Resistance Unit,
- duct work,

E

- EC Directives, , ,
- electrostatic charge,
- emergency stop,
- errors
 - See also* troubleshooting
 - correcting,
 - input units,
 - output units,
 - Racks,
 - messages,
 - fatal,
 - non-fatal,
 - startup,
 - Slave Racks, RUN output,
- execution cycle,
- Expansion CPU Racks, system configuration,
- Expansion Data Memory Unit, ,
 - mounting,
- Expansion I/O Backplanes, , ,
- Expansion I/O Racks,
 - system configuration,

F–G

- factory computers,
- GPC, baud rate,
- grounding,
 - during PC installation,
- problems,

H-I

Hard-plastic-clad Quartz Fiber: H-PCF
 cables, ,
 cords, ,

Host Link System,

humidity,

I/O Control Units,
 display modes,

I/O devices,

I/O Interface Units, , ,
 display,
 peripheral device connector,
 Rack number switch,

I/O points,

I/O Units, , ,
 general,
 shapes,
 A-shape,
 B-shape,
 C-shape,
 D-shape,
 E-shape,

indicators, CPU,

input devices,

Input Units, product list,

installation, environment,
 ambient conditions,
 cooling,
 cooling fan,
 Rack clearance,

L-M

limit switches,

manuals, CV-series,

Memory Cards, ,
 assembly,
 battery,
 replacement,
 EEPROM,
 EPROM,
 mounting,
 RAM,
 backup battery,
 removing,

Memory Unit,

model numbers, standard models,

models,

mounting
 Racks,
 conduit,
 duct work,
 preventing noise,
 units,

N-O

networks,

new CPUs,

optical connectors,

Optical Power Tester,

Optical Power Tester Head Unit,

output devices,

Output Units
 fuses,
 product list,
 relays,

P

PCs
 block diagram,
 control systems,
 cooling,
 input devices,
 operating principle,
 output devices,
 role,

peripheral device connector,

Peripheral Devices,

Personal Computer Unit,

Position Control Unit,

power
 consumption,
 interruptions,
 current consumption,
 input units,
 Link Units,
 output units,
 Special I/O Units,

power cables,

Power Supply Units, , , ,
 Backplane mounting,
 block diagram,
 current consumption,
 emergency stop,
 grounding,
 in a CPU Rack,
 power
 interruptions,
 source,
 wiring
 power source,
 terminals,

precautions, general,

process control computer,

product list,

Programmable Controllers. *See* PCs

Programming Console,
 baud rate,

R–S

Racks
 configurations,
 CPU, ,
 Expansion CPU, ,
 Expansion I/O,
 mounting locations,
 single Expansion I/O,
 SYSMAC BUS/2 Slave Racks,

Remote I/O Systems,

Remote I/O Units,
 miscellaneous,

RUN output, Slave Racks,

sensors
 control systems,
 photoelectric,
 proximity,

servomotor,

single Expansion I/O Rack, system configuration,

solenoid,

Special I/O Units, ,

specifications
 AC Input Units,
 AC/DC Input Units,
 Contact Output Units,
 CPU,
 CPU battery, lifetimes,
 DC Input Units,
 DC Input/Transistor Output Unit,
 Dummy I/O Unit,
 Dynamic DC Input Units,
 I/O Power Supply Unit,
 Interrupt Input Unit,
 Memory Card battery, lifetimes,
 number of points per common turned ON simultaneously,
 Power Supply Units,
 special considerations for C500-OA225,
 Transistor Output Units,
 Triac Input Units,
 TTL Input Units,
 TTL Output Unit,
 wiring dynamic inputs,
 wiring dynamic outputs,

SSS,

static electricity, preventing,

stepping motor,

switches
 control systems,
 limit,
 pushbutton,

SYSMAC BUS Remote I/O System,

SYSMAC BUS/2 Remote I/O System,

SYSMAC LINK System,

SYSMAC LINK Units,

SYSMAC NET Link System,

SYSMAC NET Link Units,

SYSMAC Support Software,

SYSMAC WAY,

system
See also control systems
 compatibility,
 configuration,
 C500 Expansion I/O Rack,
 configuration limits,
 Expansion CPU Rack,
 mounting locations,
 Rack configurations,
 single Expansion I/O Rack,
 with only CV-series Expansion I/O Racks,

T–W

terminal blocks,
 mounting screws,

Termination Resistance Unit,

troubleshooting
See also errors
 flowcharts
 alarm check,
 environment check,
 fault check,
 I/O check,
 main,
 power check,
 general,

weights,

wiring
 AC Power Supply Units,
 power requirements,
 DC Power Supply Units,
 internal fuse,
 power requirements,
 surge current,

duct work,

dynamic inputs,
 connection example 1: keyboard,
 connection example 2: digital switches,

dynamic outputs
 3G2A5-OD21 1,
 timing,

examples,
 AC Input,
 DC Input Units,
 sensor inputs,

I/O Units,
 precautions,
 terminal blocks,

precautions,
 electrical noise,
 inductive load surge suppressor, ,
 input leakage current,
 interlock circuits,
 output leakage current,
 output short protection,
 output surge current, ,
 transistor output residual voltage,
 voltage inputs,

terminals,
 RUN input,
 START input,

Revision History

A manual revision code appears as a suffix to the catalog number on the front cover of the manual.

Cat. No. W195-E1-5

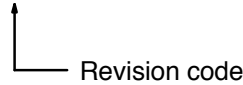

The following table outlines the changes made to the manual during each revision. Page numbers refer to the previous version.

Revision code	Date	Revised content
1	June 1992	Original production
2	April 1993	<p>Information was added on CV2000/CVM1 PCs, Personal Computer Unit, Graphic Programming Console, and Programming Console.</p> <p>The following corrections were made.</p> <p>Page 5: BASIC Unit catalogue numbers were switched and the C-to-CV Program Conversion Utility Operation Manual was deleted.</p> <p>Page 6: Expansion I/O Backplane model numbers were corrected. Remarks for Special I/O Units and Peripherals were corrected.</p> <p>Page 19: Information for the C500 Special I/O Units was corrected. Information on which Special I/O Units can be mounted to Slave Racks corrected and changed to include SYSMAC BUS Systems.</p> <p>Page 20: Last paragraph corrected concerning number of Backplane models.</p> <p>Page 51: Note added concerning Slave Racks and last sentence removed from the <i>START Input</i> and <i>RUN Output</i> descriptions.</p> <p>Page 54: Consumption for 3G2A5-ID218 corrected.</p> <p>Page 89 and other: C500-OD414 added.</p> <p>Page 90: High-speed Counter Unit (20 kcps) model number was corrected.</p> <p>Page 96: CV Support Software (CVSS) and Memory Card Writer model numbers were corrected.</p> <p>Page 97: Power consumption and shock resistance specifications were corrected.</p> <p>Page 100: Internal current consumption corrected and ohm rating in circuit configuration corrected.</p> <p>Pages 114 to 119: "Max." corrected to "Min." for power for external supply.</p> <p>Page 129: CPU battery model numbers and the graph have been corrected.</p> <p>Page 135: Model numbers have been added.</p>
2A	June 1993	<p>Several new functions have been added to the CPUs of CV-series PCs (CVM1, CV500, CV1000, and CV2000). The new CPUs have an EV1 suffix.</p> <p>Page 5: List of CV-series manuals corrected and updated.</p> <p>Page 18: Second paragraph was rewritten.</p> <p>Page 27: Information added to Remarks in top table.</p> <p>Pages 36, 138: E-shape I/O Unit replaced with newer version.</p> <p>Page 97: Note reference added to Connector Cover.</p> <p>Page 98: Connector Cover note added.</p> <p>Pages 103 and 104: Circuit configurations and terminal connections corrected for 3G2A5-ID219 and C500-ID114.</p> <p>Page 114: 3G2A5-OA223 circuit configuration corrected.</p>
3	February 1995	Changes/Additions made to add the V2 CVM1 PCs, new CPU Bus Units (Temperature Controller Data Link Unit and Ethernet Unit, and the SSS).
3A	July 1995	<p>The following corrections/additions were made.</p> <p>Page 5: Motion Control Unit added to table.</p> <p>Pages 12, 102, and 103: Note added to table.</p> <p>Page 13: Special I/O Units readable/writeable on Slave Racks corrected.</p> <p>Page 21: NC222 added to Slave Racks column of C500 Special I/O Units row.</p> <p>Page 27: Default communications settings changed and note added.</p> <p>Page 34: Descriptions of LR and GR terminals corrected.</p> <p>Page 51: Warnings added</p> <p>Pages 51 and 52: Power consumption reworded.</p> <p>Page 52: Description of LG terminal changed.</p> <p>Page 57: C500-CT021, C500-AD501, and C500-DA103 added to table.</p> <p>Pages 93 and 94: Products added to tables.</p> <p>Page 130: The value of three resistors corrected to 10 kΩ.</p>
4	December 1996	<p>Page 21: Remarks clarified for C500 Special I/O Units.</p> <p>Page 18: I/O Backplane model numbers corrected.</p> <p>Page 34: LG/GR terminal markings changed and note added on EC directives.</p> <p>Page 50, 52: Ground terminal symbol added.</p> <p>Page 51, 52, 53: Cautions and warnings added.</p> <p>Pages 56 to 58: Text and model numbers added to 3-4-7 <i>Current Consumption</i>.</p> <p>Page 58: Notes, cautions, and warning added.</p> <p>Page 63: Section added on EC directives.</p> <p>Page 75: Note added.</p> <p>Page 92: Triac model added.</p> <p>Page 101: Enclosure rating removed. Added new marks for LG and GR terminals.</p> <p>Page 119: C500-OA226 specifications added.</p> <p>Page 119, 121, 125: Fuses added.</p> <p>Page 103: Note added to control output signal on EC directives.</p> <p>Pages 123, 130: Transistor symbol changed and fuses added.</p> <p>Page 141: Weights table corrected.</p>
5	October 1999	<p>Added the <i>PRECAUTIONS</i> section in front of Section 1.</p> <p>Pages 5, 21, 58: CompoBus/D (DeviceNet) information added.</p> <p>Page 22: Expansion I/O Backplane information added to the table in <i>Remote I/O Systems</i>.</p> <p>Page 25: "CPU Backplane" corrected to "Expansion I/O Backplane" in the table.</p> <p>Page 28: Lot number information added to <i>Memory Cards</i>.</p> <p>Pages 50, 59: Torque values converted to N • m.</p> <p>Pages 50 to 54, 59: Crimp terminal information added.</p> <p>Pages 51, 54: Terminal block caution added.</p> <p>Page 70: Fuse specifications added to 4-3 <i>Output Unit Fuses</i>.</p> <p>Pages 97 to 99, 103: Standard models lists updated.</p> <p>Page 105: Vibration resistance and shock resistance corrected.</p> <p>Page 106: Work bits corrected. CompoBus/D data area added.</p>