

Features

- 1-channel isolated barrier
- 24 V DC supply (Power Rail)
- Dry contact or NAMUR inputs
- Usable as signal splitter (1 input and 2 outputs)
- Relay contact output
- Fault relay contact output
- Line fault detection (LFD)
- Reversible mode of operation
- Up to SIL 2 acc. to IEC 61508/IEC 61511

Function

This isolated barrier is used for intrinsic safety applications. It transfers digital signals (NAMUR sensors/mechanical contacts) from a hazardous area to a safe area.

The proximity sensor or switch controls a form C changeover relay contact for the safe area load. The normal output state can be reversed using switch S1. Switch S2 allows output II to be switched between a signal output or an error message output. Switch S3 is used to enable or disable line fault detection of the field circuit.

During an error condition, the relays revert to their de-energized state and the LEDs indicate the fault according to NAMUR NE44.

A unique collective error messaging feature is available when used with the Power Rail system.

Assembly

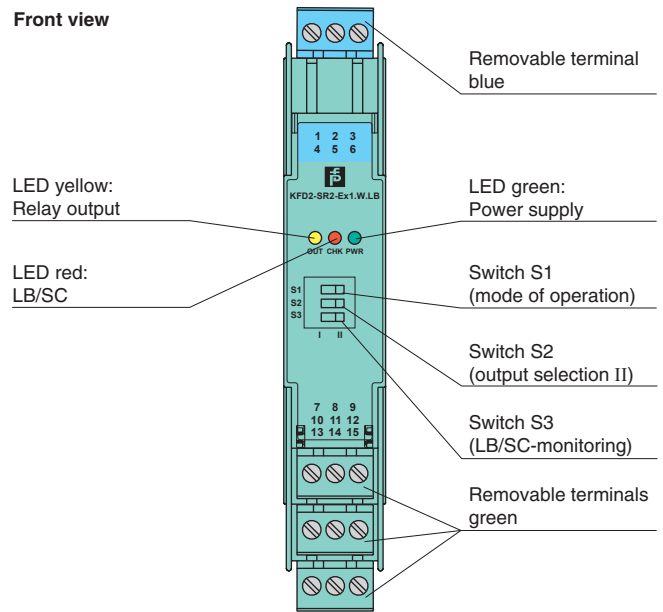

Connection

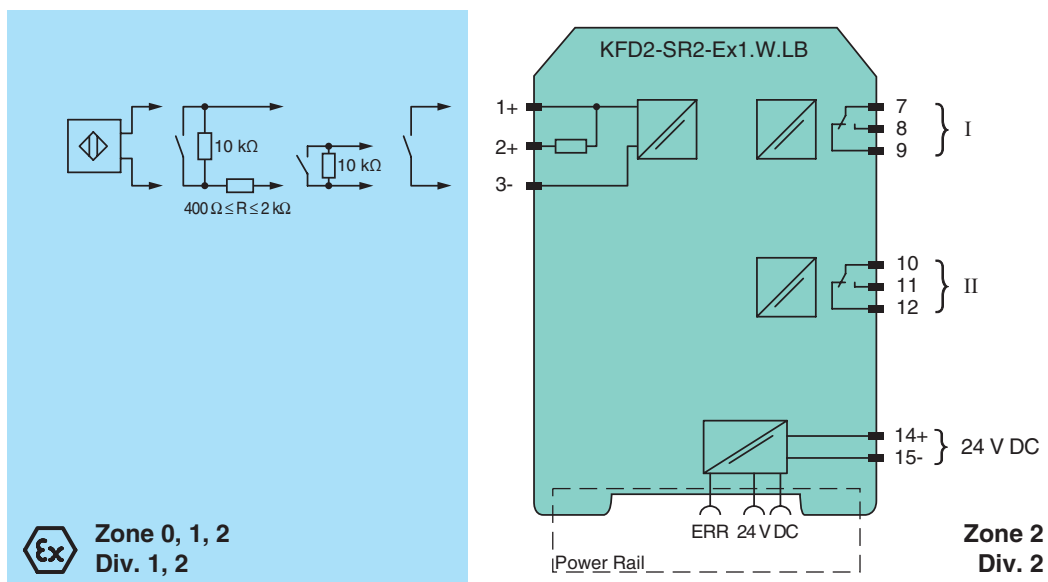

Release date 2019-09-16 Date of issue 2019-09-16 132959_eng.xml

Refer to "General Notes Relating to Pepperl+Fuchs Product Information".

General specifications		
Signal type		Digital Input
Functional safety related parameters		
Safety Integrity Level (SIL)		SIL 2
Supply		
Connection		Power Rail or terminals 14+, 15-
Rated voltage	U_r	20 ... 30 V DC
Ripple		≤ 10 %
Rated current	I_r	≤ 50 mA
Power dissipation		1 W
Power consumption		< 1.3 W
Input		
Connection side		field side
Connection		terminals 1+, 2+, 3-
Rated values		acc. to EN 60947-5-6 (NAMUR)
Open circuit voltage/short-circuit current		approx. 8 V DC / approx. 8 mA
Switching point/switching hysteresis		1.2 ... 2.1 mA / approx. 0.2 mA
Line fault detection		breakage $I \leq 0.1$ mA , short-circuit $I > 6$ mA
Pulse/Pause ratio		≥ 20 ms / ≥ 20 ms
Output		
Connection side		control side
Connection		output I: terminals 7, 8, 9 ; output II: terminals 10, 11, 12
Output I		signal ; relay
Output II		signal or error message ; relay
Contact loading		253 V AC/2 A/cos $\phi > 0.7$; 126.5 V AC/4 A/cos $\phi > 0.7$; 40 V DC/2 A resistive load
Minimum switch current		2 mA / 24 V DC
Energized/De-energized delay		approx. 20 ms / approx. 20 ms
Mechanical life		10 ⁷ switching cycles
Transfer characteristics		
Switching frequency		≤ 10 Hz
Galvanic isolation		
Input/Output		reinforced insulation according to IEC/EN 61010-1, rated insulation voltage 300 V _{eff}
Input/power supply		reinforced insulation according to IEC/EN 61010-1, rated insulation voltage 300 V _{eff}
Output/power supply		reinforced insulation according to IEC/EN 61010-1, rated insulation voltage 300 V _{eff}
Output/Output		reinforced insulation according to IEC/EN 61010-1, rated insulation voltage 300 V _{eff}
Indicators/settings		
Display elements		LEDs
Control elements		DIP-switch
Configuration		via DIP switches
Labeling		space for labeling at the front
Directive conformity		
Electromagnetic compatibility		
Directive 2014/30/EU		EN 61326-1:2013 (industrial locations)
Low voltage		
Directive 2014/35/EU		EN 61010-1:2010
Conformity		
Electromagnetic compatibility		NE 21:2006
Degree of protection		IEC 60529:2001
Input		EN 60947-5-6:2000
Ambient conditions		
Ambient temperature		-20 ... 60 °C (-4 ... 140 °F)
Mechanical specifications		
Degree of protection		IP20
Connection		screw terminals
Mass		approx. 150 g
Dimensions		20 x 119 x 115 mm (0.8 x 4.7 x 4.5 inch) , housing type B2
Mounting		on 35 mm DIN mounting rail acc. to EN 60715:2001
Data for application in connection with hazardous areas		
EU-type examination certificate		PTB 00 ATEX 2080
Marking		Ex II (1)G [Ex ia Ga] IIC Ex II (1)D [Ex ia Da] IIIC Ex I (M1) [Ex ia Ma] I
Input		Ex ia
Voltage	U_o	10.5 V

Release date 2019-09-16 12:47 Date of issue 2019-09-16 13:29:59_eng.xml

Refer to "General Notes Relating to Pepperl+Fuchs Product Information".

Current	I_o	13 mA
Power	P_o	34 mW (linear characteristic)
Supply		
Maximum safe voltage	U_m	253 V AC / 125 V DC (Attention! U_m is no rated voltage.)
Output		
Contact loading		253 V AC/2 A/cos $\phi > 0.7$; 126.5 V AC/4 A/cos $\phi > 0.7$; 40 V DC/2 A resistive load
Maximum safe voltage	U_m	253 V AC (Attention! The rated voltage can be lower.)
Fault indication output		
Maximum safe voltage	U_m	40 V DC (Attention! U_m is no rated voltage.)
Certificate		
Marking		PF 08 CERT 0803
Input		Ex ic
Voltage	U_o	10.5 V
Current	I_o	13 mA
Power	P_o	34 mW (linear characteristic)
Output		
Contact loading		253 V AC/2 A/cos $\phi > 0.7$; 126.5 V AC/4 A/cos $\phi > 0.7$; 40 V DC/2 A resistive load
Certificate		
Marking		TÜV 99 ATEX 1493 X
Output		Ex II 3G Ex nA nC IIC T4
Contact loading		50 V AC/4 A/cos $\phi > 0.7$; 40 V DC/2 A resistive load
Galvanic isolation		
Input/Output		safe electrical isolation acc. to IEC/EN 60079-11, voltage peak value 375 V
Input/power supply		safe electrical isolation acc. to IEC/EN 60079-11, voltage peak value 375 V
Directive conformity		
Directive 2014/34/EU		EN 60079-0:2012+A11:2013 , EN 60079-11:2012 , EN 60079-15:2010
International approvals		
FM approval		
Control drawing		116-0035
UL approval		
Control drawing		116-0145
CSA approval		
Control drawing		116-0047
IECEX approval		
Approved for		[Ex ia Ga] IIC, [Ex ia Da] IIIC, [Ex ia Ma] I
General information		
Supplementary information		Observe the certificates, declarations of conformity, instruction manuals, and manuals where applicable. For information see www.pepperl-fuchs.com .
Accessories		
Optional accessories		- power feed module KFD2-EB2(.R4A.B)(.SP) - universal power rail UPR-03(-M)(-S) - profile rail K-DUCT-BU(-UPR-03)

Release date 2019-09-16 12:47 Date of issue 2019-09-16 13:29:59_eng.xml

Refer to "General Notes Relating to Pepperl+Fuchs Product Information".

Configuration

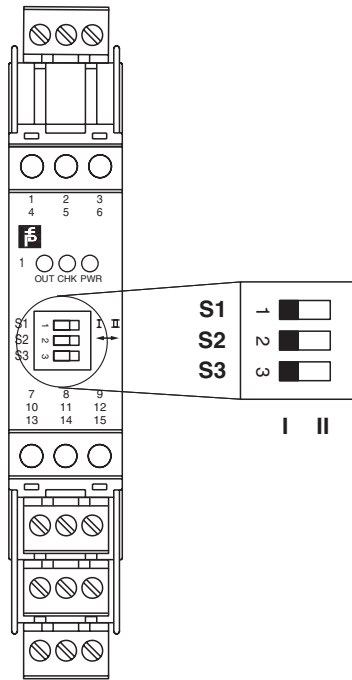

Switch position

S	Function		Position
1	Mode of operation Output I (relay) energized	with high input current	I
		with low input current	II
2	Assignment Output II (relay)	switching state like output I	I
		fault signal output (de-energized if fault)	II
3	Line fault detection	ON	I
		OFF	II

Operating status

Control circuit	Input signal
Initiator high impedance/ contact opened	low input current
Initiator low impedance/ contact closed	high input current
Lead breakage, lead short-circuit	Line fault

Factory settings: switch 1, 2 and 3 in position I

Maximum switching power of output contacts

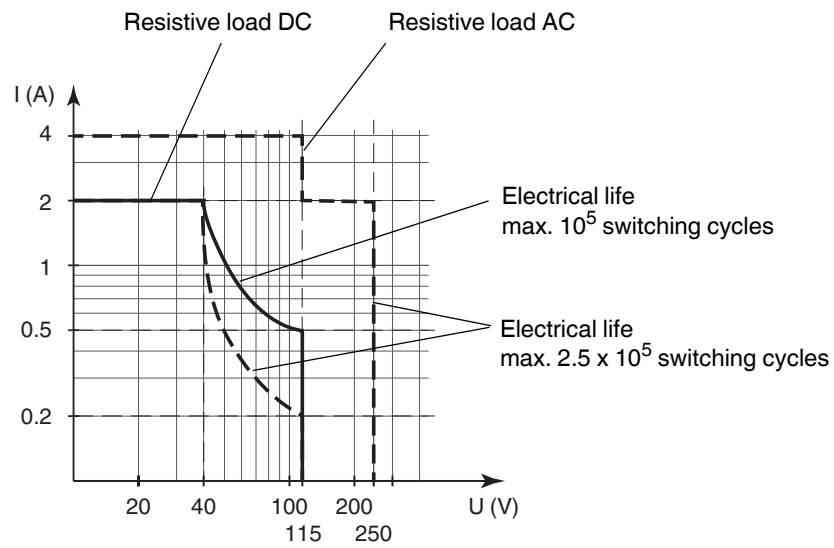

The maximum number of switching cycles is depending on the electrical load and may be higher when reduced currents and voltages are applied.