

BIM-IKE-Y1X-H1141 W/KLI3

Magnetic Field Sensor – For Pneumatic Cylinders

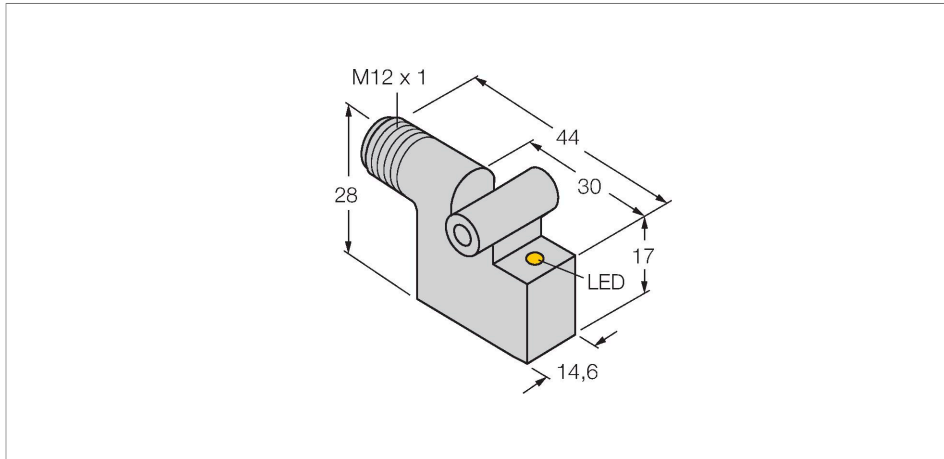

Features

- Rectangular, height 28 mm
- Metal, GD-Zn
- Magnetic-inductive sensor
- DC 2-wire, nom. 8.2 VDC
- Output acc. to DIN EN 60947-5-6 (NAMUR)
- Male connector M12 x 1
- ATEX category II 2 G, Ex zone 1
- ATEX category II 1 D, Ex zone 20
- SIL2 (Low Demand Mode) acc. to IEC 61508, PL c acc. to ISO 13849-1 at HFT0
- SIL3 (All Demand Mode) acc. to IEC 61508, PL e acc. to ISO 13849-1 with redundant configuration HFT1

Technical data

Type	BIM-IKE-Y1X-H1141 W/KLI3
Ident. no.	1056690
Pass speed	≤ 10 m/s
Repeatability	≤ ± 0.1 mm
Temperature drift	≤ 0.1 mm
Hysteresis	≤ 1 mm
Ambient temperature	-25...+70 °C
Output function	2-wire, NAMUR
Switching frequency	1 kHz
Voltage	Nom. 8.2 VDC
Current consumption non-actuated	≤ 1.2 mA
Actuated current consumption	≥ 2.1 mA
Approval acc. to	KEMA 02 ATEX 1090X
Internal capacitance (C _i)/inductance (L _i)	150 nF/150 μH
Device marking	<div style="display: flex; align-items: center;"> Ex II 2 G Ex ia IIC T6 Gb / II 1 D Ex ia IIIC T115 °C Da </div> <p style="margin-top: 5px;">(max. U_i = 20 V, I_i = 20 mA, P_i = 200 mW)</p>
Design	Rectangular, IKE
Dimensions	30 x 14.6 x 28 mm
Housing material	Metal, GD-Zn
Active area material	Plastic, PA12-GF30
Electrical connection	Connector, M12 x 1
Vibration resistance	55 Hz (1 mm)
Shock resistance	30 g (11 ms)
Protection class	IP67

Wiring diagram

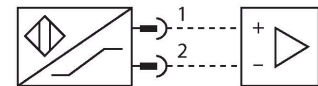
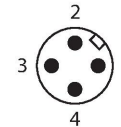

Functional principle

Magnetic field sensors are activated by magnetic fields and are especially suited for piston position detection in pneumatic cylinders. Based on the fact that magnetic fields can permeate non-magnetizable metals, it is possible to detect a permanent magnet attached to the piston through the aluminium wall of the cylinder.

Technical data

MTTF	6198 years acc. to SN 29500 (Ed. 99) 40 °C
Mounting on the following profiles	.
Cylindrical design	○ ##
Switching state	LED, Yellow
Included in delivery	KLI3

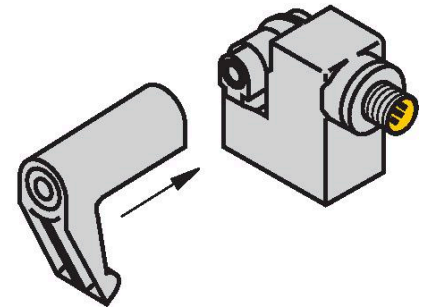
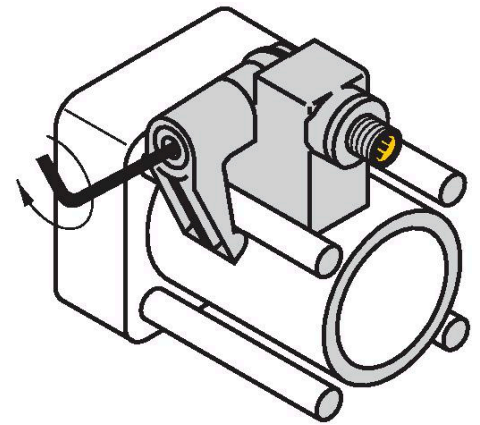

Mounting instructions

Mounting instructions/Description

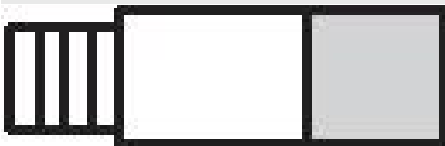

Accessories

IMC-DI-22EX-PNO/24VDC

7560003

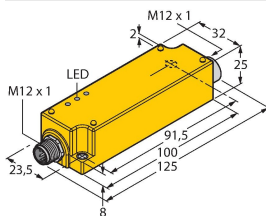

2-channel isolating switching amplifier with M12x1 males, for peripheral use, IP67, zones 2/22, input circuits II(1) Ex ia, PNP transistor output NO

IMX12-DI01-2S-2T-0/24VDC

7580020

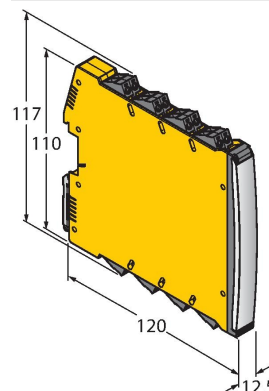

Isolating switching amplifier, 2-channel; SIL2 acc. to IEC 61508; Ex-proof version; 2 transistor outputs; input Namur signal; ON/OFF switchable monitoring of wire-break and short-circuit; toggle between NO/NC mode; signal doubling; removable screw terminals; 12.5 mm wide; 24 VDC power supply

KLI5Z

6971803

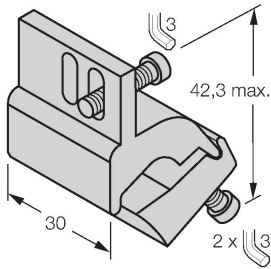

Mounting bracket for mounting magnetic field sensors on tie-rod cylinders; cylinder diameter: 32...63 mm; material: Aluminum

KLI6Z

6971806

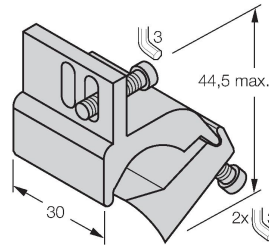

Mounting bracket for mounting magnetic field sensors on tie-rod cylinders; cylinder diameter: 50...125 mm; material: Aluminum

KLI6

6971805

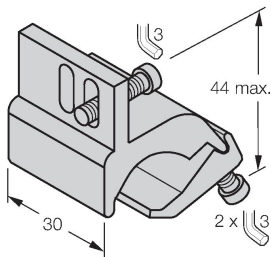

Mounting bracket for mounting magnetic field sensors on profile cylinders; cylinder diameter: 50...100 mm; material: Aluminum

KLI7

6971810

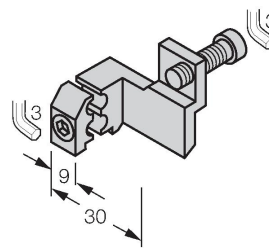

Mounting bracket for mounting magnetic field sensors on profile cylinders with external dovetail guide; cylinder diameter: 32...200 mm; material: Aluminum

KLI1

69710

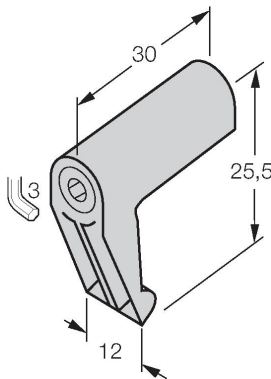

Mounting bracket for mounting magnetic field sensors on tie-rod cylinders; cylinder diameter: 32...100 mm; material: Die-cast Zinc

KLI5

6971802

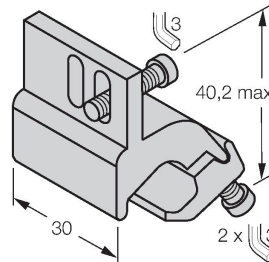

Mounting bracket for mounting magnetic field sensors on profile cylinders; cylinder diameter: 32...50 mm; material: Aluminum

KLI3

69712

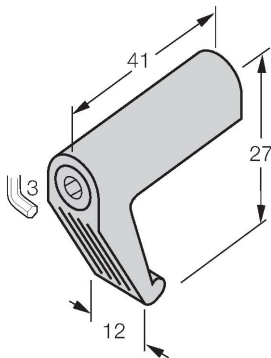

Mounting bracket for mounting magnetic field sensors on tie-rod cylinders; cylinder diameter: 63...160 mm; material: Die-cast Zinc

Operating Instructions

Intended use

This device fulfills the directive 2014/34/EC and is suited for use in explosion hazardous areas according to EN 60079-0:2012 + A11 and EN 60079-11:2012. Further it is suited for use in safety-related systems, including SIL2 as per IEC 61508. In order to ensure correct operation to the intended purpose it is required to observe the national regulations and directives.

For use in explosion hazardous areas conform to classification

II 2 G and II 1 D (Group II, Category 2 G, electrical equipment for gaseous atmospheres and category 1 D, electrical equipment for dust atmospheres).

Marking (see device or technical data sheet)

⊕ II 2 G and Ex ia IIC T6 Gb acc. to EN60079-0 and -26 und ⊕ II 1 D Ex ia IIIC T115°C Da acc. to EN60079-0

Local admissible ambient temperature

-25...+70 °C

Installation/Commissioning

These devices may only be installed, connected and operated by trained and qualified staff. Qualified staff must have knowledge of protection classes, directives and regulations concerning electrical equipment designed for use in explosion hazardous areas. Please verify that the classification and the marking on the device comply with the actual application conditions.

This device is only suited for connection to approved Exi circuits according to EN 60079-0 and EN 60079-11. Please observe the maximum admissible electrical values. After connection to other circuits the sensor may no longer be used in Exi installations. When interconnected to (associated) electrical equipment, it is required to perform the "Proof of intrinsic safety" (EN60079-14). Attention! When used in safety systems, all content of the security manual must be observed.

Installation and mounting instructions

Avoid static charging of cables and plastic devices. Please only clean the device with a damp cloth. Do not install the device in a dust flow and avoid build-up of dust deposits on the device. If the devices and the cable could be subject to mechanical damage, they must be protected accordingly. They must also be shielded against strong electro-magnetic fields. The pin configuration and the electrical specifications can be taken from the device marking or the technical data sheet. In order to avoid contamination of the device, please remove possible blanking plugs of the cable glands or connectors only shortly before inserting the cable or opening the cable socket.

Service/Maintenance

Repairs are not possible. The approval expires if the device is repaired or modified by a person other than the manufacturer. The most important data from the approval are listed.