

A19 Series Temperature Controls For Refrigeration With NEMA 1 Enclosure

Application

These controls are designed to cover a broad range of general purpose operating temperature control applications in the refrigeration, air conditioning and heating field with a minimum number of models. Typical applications are: frozen food cases, display cases, beverage coolers, milk coolers, walk-in boxes, water chillers, etc.

Various control ranges are available to cover working temperatures from -30 to 225°F (-35 to 105°C). Closed tank fittings and bulb wells are available for immersion applications.

Single-stage controls less enclosure and two-stage controls with or without enclosure also are available. Contact the nearest Johnson Controls office or contact

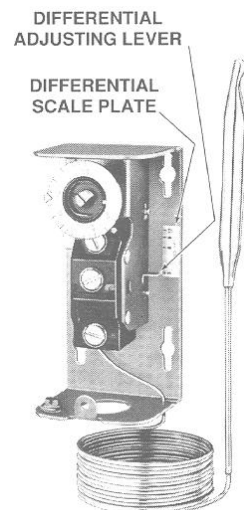

Fig. 1: Interior of an A19 with differential adjustment. Differential adjustment is concealed when cover is on control.

Specifications

Case Material	.062" (1.6mm) Cold Rolled Steel
Conduit Opening	7/8" Diameter Hole for 1/2" Conduit
Contact Unit	Snap-Acting Contacts in Dusttight Enclosure
Cover Material	.025" (0.6mm) Cold Rolled Steel
Finish	Gray Baked Enamel
Shipping Weight	Individual Pack 1 lb (0.45 kg)
	Overpack of 50 55 lb (25 kg)
Terminal Screws	No. 8-32 x 1/4" Binder Head with Cup Washers

Customer Service.

Range and Differential Specifications

Range F C	Differential F C			Bulb Size In. mm	Max. Ambient F C (1)
	Adjustable	Standard (Fixed)	Close (Fixed)		
-30 to 50	5 to 20	5	2.5	.375 x 4	140
-35 to 10	2.8 to 11.1	2.8	1.4	9.5 x 102	60
-30 to 100	3 to 12	3	1.5	.375 x 4	140
-35 to 40	1.7 to 6.7	1.7	0.8	9.5 x 102	60
-20 to 60	5 to 20	5	2.5	.375 x 4	140
-6 to 15	2.8 to 11.2	2.8	1.4	9.4 x 102	60
20 to 80	3.5 to 14	3.5	1.75	.375 x 5	140
-5 to 28	1.9 to 7.8	1.9	0.97	9.5 x 127	60
25 to 225	7 to 28	7	3.5	.375 x 3	275
-3 to 105	3.9 to 15.6	3.9	1.9	9.5 x 76	135
30 to 50	4 to 16	4	2	.375 x 2.625	190
0 to 10	2.2 to 8.9	2.2	1.1	9.5 x 67	88
30 to 110	3.5 to 14	3.5	1.75	.375 x 5	140
0 to 43	1.9 to 7.8	1.9	0.97	9.5 x 127	60
40 to 90	3.5 to 14	3.5	1.75	.375 x 6	140
5 to 32	1.9 to 7.8	1.9	0.97	9.5 x 152	60
50 to 130	3.5 to 14	3.5	1.75	.375 x 5	170
10 to 55	1.9 to 7.8	1.9	0.97	9.5 x 127	77

(1) Maximum bulb temperature which the element can withstand at infrequent intervals during life of control, such as shipping conditions. This is not the temperature which the control can withstand on repeat cycles. Maximum ambient temperature around control case is 140°F (60°C).

All Series A19 temperature controls are designed for use *only* as operating controls. Where an operating control failure would result in personal injury and/or loss of property, it is the responsibility of the installer to add devices (safety, limit controls) or systems (alarm, supervisory systems) that protect against, or warn of, control failure.

Features

- Compact general purpose temperature controls with a wide selection of models.
- Dependability -- precision snap-acting contacts in dusttight enclosure and liquid filled sensing element are field proven.
- Precision "repeat" accuracy which is unaffected by barometric pressure and cross ambient temperature problems.
- Concealed differential adjustment discourages unauthorized adjustment changes.
- Extremely close differentials -- fixed or adjustable.
- "Trip-free" manual reset -- reset must be *pressed and released* before operation will resume. Contacts cannot be blocked in the closed position.

General Description

These compact controls are supplied with fixed or adjustable differential. Controls supplied with adjustable differential have an internal scale plate indicating increments of differential.

Knob range adjustment and visible scale are standard. Models are available with a knob for field convertible adjustment. These models are



Fig. 2: The A19 with external range adjustment.

supplied with a snap-in plug in the cover for concealed screwdriver slot adjustment. A bulb mounting clip with sheet metal screw is supplied with remote bulb models. A special designed, field-proven liquid filled sensing element provides precision "repeat" accuracy which is unaffected by barometric pressure and cross ambient temperature problems.

The A19ACA and A19ADB controls lockout requiring that reset be pressed and released before operation will resume. All other controls in the series are automatic recycling.

Optional Constructions

Ambient Compensation

Available on fixed differential and manual reset models at extra cost, if required.

Capillary Length

Standard is 6 feet (1.8 m). Optional lengths are 10 feet (3m), 15 feet (4.6 m) and 20 feet (6.1m). Quantity orders.

Mounting Brackets

Optional at extra cost.

Electrical Rating Tables

Standard Differential

Volts, AC	120	208	240
Full Load Amps.	16.0	9.2	8.0
Locked Rotor Amps	96.0	55.2	48.0
Non-Inductive or Resistance Load Amps. † (Not Lamp Loads)	22 Amps. 120 to 277 VAC		
Pilot Duty --- 125 VA, 24 to 600 VAC			

†SPST rating

Standard Differential With Lockout

Volts, AC	120	208	240
Full Load Amps.	16.0	9.2	8.0
Locked Rotor Amps.	96.0	55.2	48.0
Non-Inductive or Resistance Load Amps. (Not Lamp Loads)	16.0	9.2	8.0
Pilot Duty --- 125 VA, 24 to 600 VAC			

Close Differential

Volts, AC	120	208	240
Full Load Amps.	6.0	3.4	3.0
Locked Rotor Amps.	36.0	20.4	18.0
Non-Inductive or Resistance Load Amps. (Not Lamp Loads)	10 Amps. 24 to 277 VAC		
Pilot Duty --- 125 VA, 24 to 277 VAC			

Packing Nut

Part No. FTG13A-600R is available for closed tank applications where the temperature does not fall below -35°F (-37°C) or exceed 250°F (121°C). Maximum liquid pressure limit is 150 psig (1034 kPa). For applications where the temperature or liquid pressure exceeds these limits specify Style 4 element with all metal packing nut as an integral part of the control.

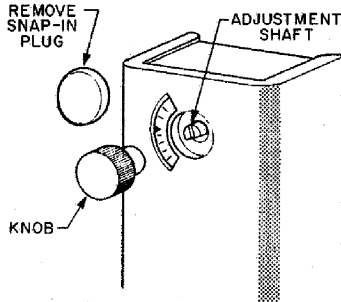

Fig. 3: Drawing showing snap-in plug removed and the knob in line to assemble. Press the knob onto the slotted shaft

Range Adjuster

Screwdriver slot with visible scale or screwdriver slot with internal scale and solid cover optional at no extra cost (quantity orders only). Models are available with a knob for field convertible adjustment and a remote bulb mounting clip. This provides conversion to knob, concealed screwdriver slot or external screwdriver slot adjustment.

Example: Type A19ABC is a remote bulb temperature control with NEMA 1 enclosure, adjustable differential, SPDT contacts and standard differential (1 hp). All combinations of the above letters or Types are not necessarily available. Contact Customer Service at 1-800-ASK-JNSN.

Repairs and Replacement

Field repairs must not be made. For a replacement control contact the nearest Johnson Controls wholesaler.

Type Number Chart

A19	A	Remote bulb, NEMA 1
	B	Integral bulb, NEMA 1
	A	Fixed differential
	B	Adjustable differential
	C	Lockout on low
	D	Lockout on high
	A	Open low, standard differential
	B	Open high, standard differential
	C	SPDT, standard differential
	D	Open low, close differential
	E	Open high, close differential
	F	SPDT, close differential

Ordering Information

- To order, specify Product Number if available.
- Where Product Number is not available, specify Type Number and the following:
 - Range required.
 - Style of element.
 - Manual reset, if needed.
 - Length of capillary, 6 feet (1.8 m) is standard.
 - Ambient compensation, if required.
 - Type of adjustment, knob, screwdriver slot, concealed or factory sealed.
 - Fixed or adjustable differential.
- Specify bulb well, if required, by Part Number.
- Specify packing nut, Part Number FTG13A-600R, if required for style 1 bulb with support tube.

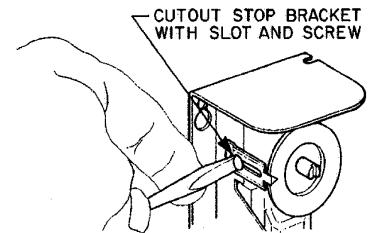

Fig. 4: The controls have a screw type cutout stop. The stop screw must be loosened and moved to the stop setting desired. Tighten screw after setting is made.

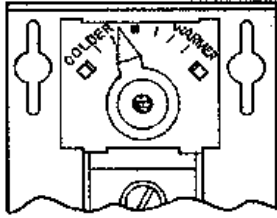

Fig. 5: Concealed range adjustment furnished on milk cooler controls: 30 to 50°F (0 to 10°C) range. Available on other models on quantity orders.

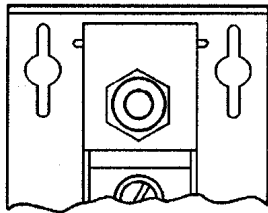

Fig. 6: Factory sealed setting -- optional at no extra cost on quantity orders.

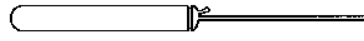

Fig. 7: Style 1 drawn bulb.

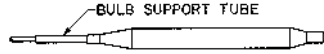

Fig. 8: Style 1 swaged bulb with support tube. (Add FTG13A-600R packing nut to Style 1 swaged bulb when used in closed tank.)

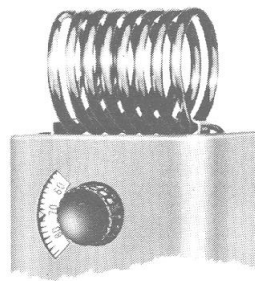

Fig. 9: Style 3 element attached to the case.

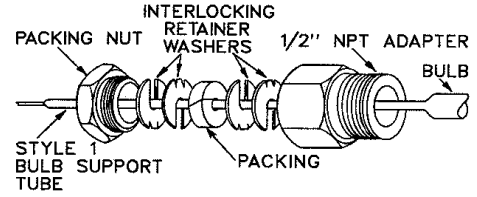
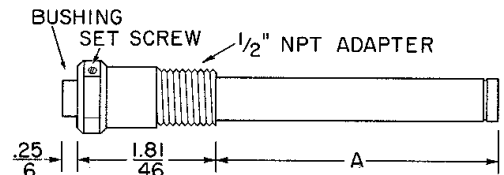
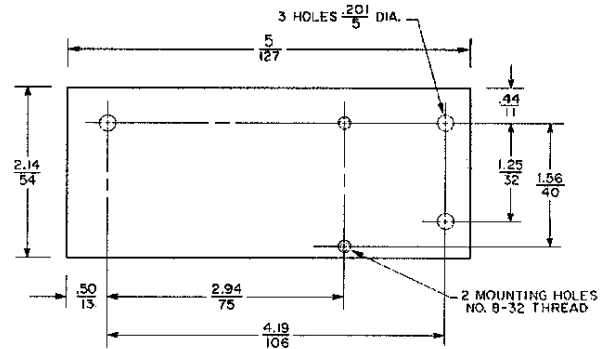
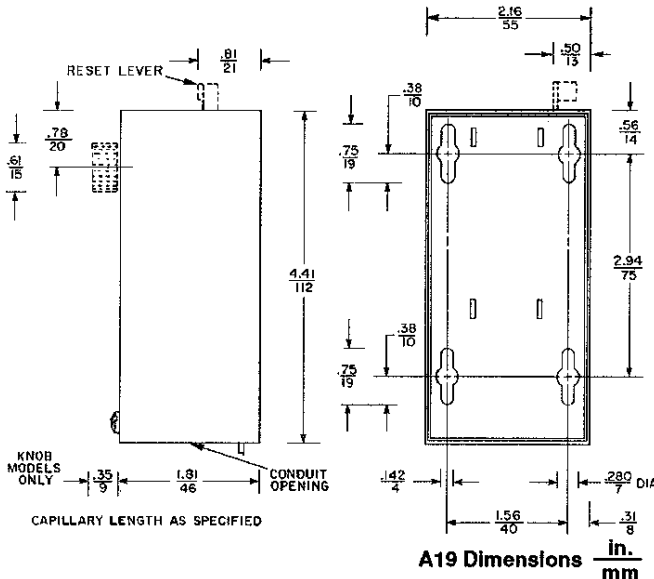

Fig. 10: Part No. FTG13A-600R packing nut assembly. (Use with Style 1 bulb with support tube for direct immersion applications.)



BULB WELL NUMBER	DIMENSION "A"
WEL14A-600R(MONEL)	4.75 (121)
WEL14A-602R	4.94 (125)
WEL14A-603R	5.81 (148)
WEL16A-601R	2.81 (71)

Fig. 11: Bulb well for liquid immersion applications where a temperature bulb may be removed without draining the tank.



Performance specifications appearing herein are nominal and are subject to accepted manufacturing tolerances and application variables.



Building Technologies & Solutions
507 E. Michigan Street, Milwaukee, WI 53202

© Johnson Controls and PENN are registered trademarks of Johnson Controls in the United States of America and/or other countries. All other trademarks used herein are the property of their respective owners. © Copyright 2018 by Johnson Controls. All rights reserved.