









Quick Selection Guide





Specifications	 <p>801 General Purpose</p>	 <p>802G Gravity Return</p>	 <p>802M and 802MC Pre-Wired Factory Sealed</p>	 <p>802R Sealed Contact</p>
Description	<ul style="list-style-type: none"> General purpose limit switch for a wide variety of applications 	<ul style="list-style-type: none"> Plug-in gravity return switch Designed for conveyor-type operations with small or lightweight objects 	<ul style="list-style-type: none"> Compact, prewired switch Factory sealed to meet the requirements of demanding applications, wet or dry 	<ul style="list-style-type: none"> Similar construction to the 802T nonplug-in Glass hermetically sealed reed switch (used as the switching element to provide high contact reliability)
Features	<ul style="list-style-type: none"> Mounting option; surface 	<ul style="list-style-type: none"> Mounting options: surface, manifold 	<ul style="list-style-type: none"> Cable entry and wire strands (epoxy sealed to protect against fluids entering or wicking into the switch) Mounting options: surface. 	<ul style="list-style-type: none"> Enclosure: gasketed, transparent plastic cover Allows inspection of terminals without removing the cover Mounting option: surface
Contact Rating	<ul style="list-style-type: none"> NEMA A600 	<ul style="list-style-type: none"> NEMA B600 	<ul style="list-style-type: none"> 2-circuit: NEMA A600 4-circuit: NEMA B300 	<ul style="list-style-type: none"> NEMA B600
Temperature Rating	<ul style="list-style-type: none"> -0...40°C (32...104°F) 	<ul style="list-style-type: none"> 0...110°C (32...230°F) 	<ul style="list-style-type: none"> 0...80°C (32...176°F) 	<ul style="list-style-type: none"> -29...121°C (-20...250°F)
Actuators	<ul style="list-style-type: none"> Lever, maintained 	<ul style="list-style-type: none"> Three adjustable rod levers 	<ul style="list-style-type: none"> Lever, maintained Top and side push (with or without rollers) 	<ul style="list-style-type: none"> Lever Low operating force Top and side push (with or without rollers) Cat whisker Wobble stick
Enclosure	<ul style="list-style-type: none"> NEMA Type 1, Type 4 or Type 7 and 9 	<ul style="list-style-type: none"> NEMA Type 1 	<ul style="list-style-type: none"> NEMA Types 1, 4, 4X, 6P and 13; IP67 (IEC529) 	<ul style="list-style-type: none"> NEMA Types 13
Additional Info	<ul style="list-style-type: none"> See page 5-9 	<ul style="list-style-type: none"> See page 5-13 	<ul style="list-style-type: none"> See page 5-15 	<ul style="list-style-type: none"> See page 5-34





Limit Switches

Quick Selection Guide

 802T Plug-In Style	 802T Low Energy	 802T NonPlug-In Style	 802X Watertight or Hazardous Location	 802XR Sealed Contact Hazardous Location
<ul style="list-style-type: none"> • Plug-in construction provides quick and easy installation • New front-mounting design and method of mode change in head make it easy to apply 	<ul style="list-style-type: none"> • Similar body style to standard 802T plug-in limit switches • Direct connection to PLCs and other low energy circuits 	<ul style="list-style-type: none"> • Ideal for applications which require heavy-duty pilot ratings • High degree of versatility and a rugged, oiltight construction 	<ul style="list-style-type: none"> • NEMA Types 7 and 9 • Designed for hazardous locations only • Class I, Groups B, C, D • Class II, Groups E, F and G, Class III 	<ul style="list-style-type: none"> • Designed for hazardous locations • Contains sealed glass contact switch for greater contact reliability
<ul style="list-style-type: none"> • Circuitry: 4-circuit version (for most types the same size as the 2-circuit switches) • Seals: Viton seals for special applications • Mounting options: surface, manifold 	<ul style="list-style-type: none"> • Conduit and mini receptacle wiring options • Plug-in style for ease of wiring • UL listed, CSA certified and CE marked for all applicable directives. 	<ul style="list-style-type: none"> • Dual, air operated • 2-pole vertical or horizontal lever • Operated time delay • Mounting options: surface, cavity, manifold 	<ul style="list-style-type: none"> • Mounting option: surface 	<ul style="list-style-type: none"> • Mounting option: surface
<ul style="list-style-type: none"> • 2-Circuit: NEMA A600 • 4-Circuit: NEMA A300 	<ul style="list-style-type: none"> • 1 N.O. and 1 N.C. contact • Slow break before make • DC 0.40 VA load per pole max and 0.025 VA load per pole min. 	<ul style="list-style-type: none"> • NEMA A600 	<ul style="list-style-type: none"> • NEMA A600 	<ul style="list-style-type: none"> • NEMA B600
<ul style="list-style-type: none"> • -18...110°C (0...230°F); • Optional: -40...110°C (-40...230°F), 	<ul style="list-style-type: none"> • -18...110 (0...230) • -40...110 (-40...230) low temp model 	<ul style="list-style-type: none"> • -18...54°C (0...130°F) • Optional: -29...121°C (-20...250°F) 	<ul style="list-style-type: none"> • -46...121°C (-50...250°F) 	<ul style="list-style-type: none"> • -29...121°C (-20...250°F)
<ul style="list-style-type: none"> • Lever • Maintained • Low operating force • Top and side push (with or without rollers) • Cat whisker • Wobble stick • Neutral position 	<ul style="list-style-type: none"> • Lever • Side push rod • Top push roller • Side push vertical roller 	<ul style="list-style-type: none"> • Lever • Maintained, low operating force • Top and side push (with or without rollers) • Cat whisker • Wobble stick • Neutral position 	<ul style="list-style-type: none"> • Lever • Maintained, top and side push (with or without rollers) • Wobble stick • Neutral position 	<ul style="list-style-type: none"> • Lever • Top and side push (with or without rollers) • Wobble stick
<ul style="list-style-type: none"> • NEMA Types 1, 4, 6P (select side rotary styles), 13 	<ul style="list-style-type: none"> • IP30 	<ul style="list-style-type: none"> • NEMA Types 1, 13 	<ul style="list-style-type: none"> • NEMA Types 7 and 9 • Class I, Groups B, C or D • Class II, Groups E, F or G • Class III 	<ul style="list-style-type: none"> • NEMA Types 7 and 9 • Class I, Groups B, C or D • Class II, Groups E, F or G
<ul style="list-style-type: none"> • See page 5-41 	<ul style="list-style-type: none"> • See page 5-48 	<ul style="list-style-type: none"> • See page 5-54 	<ul style="list-style-type: none"> • See page 5-74 	<ul style="list-style-type: none"> • See page 5-81

Quick Selection Guide

Specifications	 802B Compact	 802B Precision	 802B Small Precision	 802T Safety Limit Switches
Description	<ul style="list-style-type: none"> • Compact metal body • Prewired to maintain enclosure seals • Industry standard mounting for ease of installation. 	<ul style="list-style-type: none"> • Precision style limit switch • Industry standard mounting • Low trip and reset points for more precise sensing 	<ul style="list-style-type: none"> • metal bodied for use in industrial applications • Twelve different styles available for solving multiple applications 	<ul style="list-style-type: none"> • designed for use in control reliable applications and safety applications per ISO 14119
Features	<ul style="list-style-type: none"> • 3 m cable standard • AC or DC LED versions • Low current versions • Booted and panel mount versions • UL/CSA and CE Marked for all applicable directives 	<ul style="list-style-type: none"> • 1/2 in. NPT conduit entry • Grounding screw • Booted models • Side and flange mounting available • UL/CSA and CE Marked for all applicable directives 	<ul style="list-style-type: none"> • 12 different actuators • Screw termination • Small size • Booted and Panel mount versions • UL/CSA and CE marked for all applicable directives 	<ul style="list-style-type: none"> • Direct opening action • Snap acting contacts • Plugged metal construction • Long life and reliability • Plug-in design • NEMA 6P/IP67 sealing
Contact Rating	<ul style="list-style-type: none"> • SPDT Form C • NEMA B300 	<ul style="list-style-type: none"> • SPDT Form C • 15 A @ 125/250/480 V AC 	<ul style="list-style-type: none"> • SPDT Form C • NEMA B300 	<ul style="list-style-type: none"> • 2-circuit: A600/AC-15 G300/DC-13 • 4-circuit: A300 G300/DC-13
Temperature Rating	<ul style="list-style-type: none"> • -10...70°C (14...158°F) 	<ul style="list-style-type: none"> • -10...80°C (14...176°F) 	<ul style="list-style-type: none"> • -10...80°C (14...176°F) 	<ul style="list-style-type: none"> • -18C...+110°C (0F...+230°F)
Actuators	<ul style="list-style-type: none"> • Rotary arm • Center rotary arm • Wobble stick • Top push • Top push bevel • Top push roller • Top push cross roller 	<ul style="list-style-type: none"> • Top push • Top push roller • Top push cross roller • Roller lever • One-way roller lever 	<ul style="list-style-type: none"> • Top push • Top push roller • Top push cross roller • Hinge lever • Short hinge lever • Roller lever • Short roller lever • One-way roller lever • Short one-way roller lever 	<ul style="list-style-type: none"> • Lever • Top push roller • Side push vertical roller • Side push horizontal roller
Enclosure	<ul style="list-style-type: none"> • NEMA 1, 3, 4, 6, 12, 13 and IP67 	<ul style="list-style-type: none"> • Nonbooted: NEMA 1 and IP 60 • Booted: NEMA 1, 3, 4 and IP65 	<ul style="list-style-type: none"> • NEMA 1, 3, 4, 6, 13 and IP67 	<ul style="list-style-type: none"> • NEMA 4, 6P, 12, 13 and IP67
Additional Info	<ul style="list-style-type: none"> • See page 5-88 	<ul style="list-style-type: none"> • See page 5-97 	<ul style="list-style-type: none"> • See page 5-105 	<ul style="list-style-type: none"> • See page 5-109

 <p>440P-A 22 mm Metal Safety Limit switches</p>	 <p>440P-C 22 mm Plastic Safety Limit switches</p>	 <p>440P-M 30 mm Metal Safety Limit switches</p>	 <p>440P-M 15 mm Plastic Safety Limit switches</p>	 <p>Operating Lever</p>
<ul style="list-style-type: none"> • Compact die-cast alloy metal body with prewired 2 m cable exiting bottom or side of switch mounting for ease of installation • Industry standard mounting for ease of installation • Choice of actuator heads 	<ul style="list-style-type: none"> • Conforms to EN50047 (22 mm) • Glass reinforced thermoplastic housing • Most feature direct opening contacts designed to meet IEC 947 • Available in snap-acting, slow make/break with 2 or 3 pole contact arrangement • Heads can be rotated in 90° increments for flexible mounting 	<ul style="list-style-type: none"> • Conforms to EN50041 (30 mm x 60 mm) • Cast aluminum housing • Most feature direct opening contacts designed to meet IEC 947 • Available in snap-acting, slow make/break with 2, 3 or 4 pole contact arrangement. • Heads can be rotated in 90° increments for flexible mounting 	<ul style="list-style-type: none"> • Small size with mounting hole options • Choice of actuator position • UL approved glass filled polyester housing 	<ul style="list-style-type: none"> • To be used with 802T, 802M, 802MC, 802X and 802XR limit switches
<ul style="list-style-type: none"> • Rugged die cast enclosure • Positive operation, forced disconnection of contacts (direct opening action) • Snap-acting contact actuation • Contacts 1 N.C. + 1 N.O. • Prewired 2 meter cable, bottom or side exit • UL Recognized, TÜV and CE Marked for all applicable directives 	<ul style="list-style-type: none"> • Available in 1/2 in. NPT, M20 and QD versions • Cat. 1 device per EN954-1, dual-channel interlocks suitable for Cat. 3 or 4 systems • cULus, TÜV, CCC, and CE Marked for all applicable directives • Mounting options: surface 	<ul style="list-style-type: none"> • Available in 1/2 in. NPT, M20 and QD versions • Cat. 1 device per EN954-1, dual-channel interlocks suitable for Cat. 3 or 4 systems • cULus, TÜV, CCC, and CE Marked for all applicable directives • Mounting options: surface 	<ul style="list-style-type: none"> • Positive operation, forced disconnection of contacts • Contacts, 1 N.C. & 1 N.O. • CSA NRTL/C and CE Marked for all applicable directives 	<ul style="list-style-type: none"> • Various lengths materials and styles to suit specific applications
<ul style="list-style-type: none"> • 1 N.O. and 1 N.C. snap acting contact, AC15/B330, DC 13/G300 	<ul style="list-style-type: none"> • A600/AC-15 • N600/DC-13 	<ul style="list-style-type: none"> • A600/AC-15 • N600/DC-13 	<ul style="list-style-type: none"> • 1 N.O. and 1 N.C. contact • Slow break before make 	<p>—</p>
<ul style="list-style-type: none"> • 2...+70°C (35.6...158°F) 	<ul style="list-style-type: none"> • -25...80°C (-13...176°F) 	<ul style="list-style-type: none"> • -25...80°C (-13...176°F) 	<ul style="list-style-type: none"> • -25...80°C (-113...176°F) 	<p>—</p>
<ul style="list-style-type: none"> • Roller plunger • Dome plunger • Cross roller plunger • Lever arm 	<ul style="list-style-type: none"> • Roller plunger • Dome plunger • Hinge lever • Short lever • Offset hinge • Adjustable lever • Large rubber roller 	<ul style="list-style-type: none"> • Roller plunger • Dome plunger • Short lever • Adjustable lever • Rod lever • Spring rod • Telescope arm 	<ul style="list-style-type: none"> • Roller plunger 	<ul style="list-style-type: none"> • Rod levers • Roller levers
<ul style="list-style-type: none"> • NEMA 1, IP66 and IP67 	<ul style="list-style-type: none"> • IP66 	<ul style="list-style-type: none"> • IP66 	<ul style="list-style-type: none"> • IP30 	<p>—</p>
<ul style="list-style-type: none"> • See page 5-114 	<ul style="list-style-type: none"> • See page 5-116 	<ul style="list-style-type: none"> • See page 5-122 	<ul style="list-style-type: none"> • See page 5-128 	<ul style="list-style-type: none"> • See page 5-130

Technical Definitions and Terminology

Actuator: A switch mechanism that when moved as intended, operates the switch contacts. This mechanism transmits the applied force from the actuating device...the contact block, causing the contacts to operate.

Actuator Free Position: The initial position of the actuator when there is no external force (except gravity) applied to the actuator.

Actuator Operating Position: The position of the actuator when the contacts operate.

Actuator Resetting Position: The position of the actuator at which the contacts move from the operated position to the "normal" position.

Differential Travel (Travel to reset contacts): The angle or distance through which the actuator moves from the contact operating position to the actuator resetting position, or the distance between the operating point and the release point.

Normal Contact Position: The position of the contacts when no operating force is applied.

Operating Contact Position: The position to which the contacts move when the actuator is deflected to or beyond the actuator operating position.

Operating Force: The straight line force in the designed direction applied to the switch actuator to cause the contacts to move to the operated position.

Operating Torque: The torque that must be applied to the actuator to cause the movable contacts to move to the operated contact position.

Overtravel: The movement of the actuator beyond the contact operating position.

Pretravel (Travel to the operate contacts): Travel to operate the contacts from the actuator free position.

Slow Make-Slow Break: A type of contact structure with no overcenter mechanism. Contacts move at a speed directly proportional to the speed of operation of the actuator. Contacts may touch with little contact pressure.

Snap Action: In this type of contact structure, movement of the actuator applies force to an overcenter mechanism, which creates a fast change in contact state once the overcenter position has been exceeded.

Snap Action/IEC Positive Opening Action: This contact structure is very similar to the snap action contact with one addition: continued operation of the operating mechanism beyond the normal snap action position applies force directly to the normally closed (N.C.) contact if it has not opened with the snap action mechanism. This helps to ensure opening of even a welded contact. For example, if a contact has a snap action operating point at 40° rotary movement, the direct opening action point may be at 60° or more. No direct opening action forces are applied to the N.O. contact.

Total or Maximum Travel: The sum of the pretravel and the overtravel.

Application Considerations

Actuator Consideration

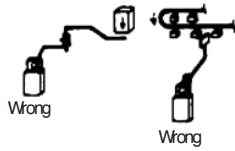

Limit switches are designed for proper performance with the actuators with which they are supplied. Supplementary actuators should not be used unless the limit switches are specifically designed for them.

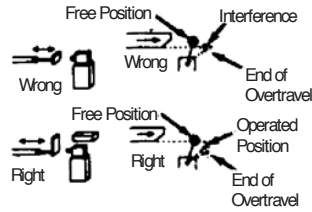

Operating mechanism for limit switches should be so designed that under any operating or emergency conditions the limit switch is not operated beyond its overtravel limit position. A limit switch should not be used as a mechanical stop.

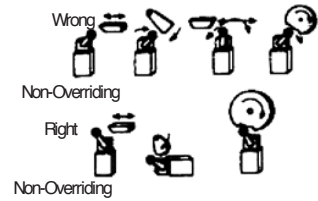

For limit switches with lever actuators, the actuating force should be applied as nearly perpendicular to the lever as practical and perpendicular to the shaft axis about which the lever rotates.

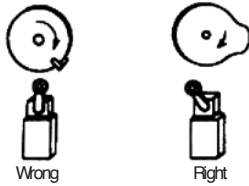

Where relatively fast motions are involved cam arrangements should be such that the actuator does not receive a severe impact. Cams should be designed such that the limit switch will be held operated long enough to operate relays, valves, etc.

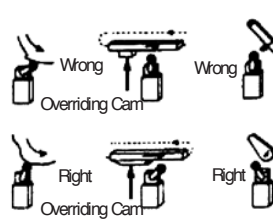

Cam or dog arrangements should be such that the actuator is not suddenly released to snap back freely.

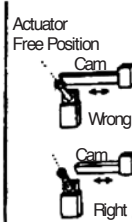

A limit switch actuator must be allowed to move far enough for positive operation of the contacts.

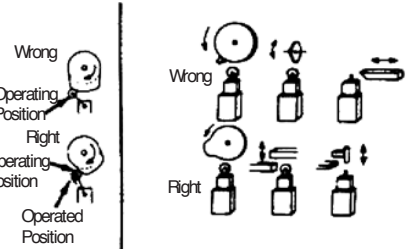

For limit switches with push rod actuators the actuating force should be applied as nearly as possible in line with the push rod axis.

Location and Installation

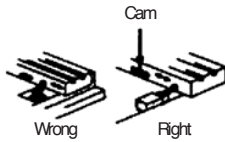

Limit switches should be mounted rigidly and in readily accessible locations with suitable clearances to permit easy service and replacement when necessary. Cover plates should face the maintenance access point.

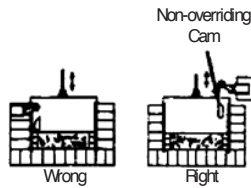

Limit switches should not be used in locations where temperature or atmosphere conditions are beyond those for which they have been specifically designed.

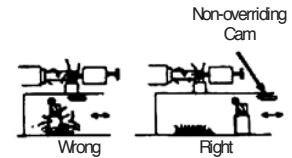

Limit switches should be placed in locations where machining chips do not accumulate under normal operating conditions.

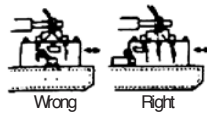

Limit switches should not be submerged in or splashed with oils, coolants or other liquids.

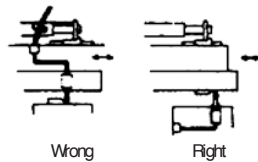

The location of airtight limit switches and the method of connecting them should be such that condensation in the conduit cannot enter the switch enclosure.

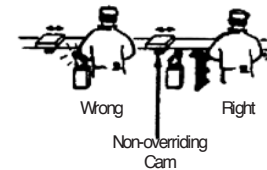

Limit switches should be mounted in locations which will prevent false operation by normal movements of operator or machine components.



801-ASA11



801-ASC17



801-CMC21



801-FSC148



801-ASC1411

Description

The Bulletin 801 line of general purpose limit switches includes many types of switches for use in a wide variety of applications. Many different contact arrangements are available. Slow and snap action contact operating mechanisms are available. Snap action limit switches are designed to provide high snap through force once the mechanism has traveled the required distance. Refer to the table on page 5-12 for limit switch selection.

Figure 1

Lever on right side as illustrated. Clockwise operation only. Lever can be adjusted through 360°.

Figure 2

Contacts are operated in both directions of roller lever. With roller on inside, lever is adjustable through 49° either side of center line. With roller on outside, lever is adjustable through 360°.

Figure 3

Similar to Figure 2 except roller lever is longer for use where more space is necessary between limit switch and its operating device. The total height from base of limit switch to the end of roller is 181.0 mm (7.125 in.).

Figure 4

Same contact operation in either direction, with roller on either inside or outside. Starting position of lever is adjustable 43° either side of center line.

Figure 5

Contact operation is obtained only in direction shown. Lever is free to move in opposite direction, but contacts are not actuated. With roller on inside, starting position of lever can be adjusted through 128° from extreme left position; with roller on outside, the roller lever is adjustable through 360°.

Figure 6

Similar to Figure 5, except that operation is to the left.

Figure 7

For clockwise operation. Ratchet type. When lever is moved to right, contacts are operated. Lever is spring return, but contacts remain in the operated position. Next movement of roller lever to the right returns the contacts to their original position. This completes cycle of operation. Lever is adjustable through 360°.

Figure 8

Similar to Figure 7 except that operation is counterclockwise.

Figure 9

Contacts are operated when fork lever is operated in one direction and are restored to original position when lever is operated in the reverse direction. Rod or Chain/Stroke Type Actuators not shown.

Figure 10

Roller lever on right side. Roller 34.9 mm (1.375 in.) in diameter. Lever travels through 30° arc. Downward travel of roller, 33.3 mm (1.312 in.).

Figure 11

Similar to Figure 10, except roller has a rubber trim, 76.2 mm (3 in.) in diameter. Downward Travel of roller, 42.1 mm (1.656 in.).

Figure 12

Roller lever on right side. Steel roller, 34.9 mm (1.375 in.) in diameter. Lever travel, either direction, 30°.

Figure 13

For clockwise operation. Roller, 1.375 in. (34.9 mm) diameter. Downward linear travel of roller, 50 mm (1.969 in.).

● For NEMA 7 & 9 housing, reduce total height by 1.6 mm (0.063 in.).

Figure 14

Contact operation obtained when fork lever is moved in direction shown and restored to original position when lever is operated in reverse direction.

Figure 15

Contacts operate in the direction shown. Track type limit switch with roller fork lever. Rollers 22.2 mm (0.875 in.) diameter hardened steel.

Figure 16

Contacts operate when the lever is moved in either direction. Should only be used where the link between lever and operating mechanism is short, so that the weight of the connecting mechanism will not offset the force of the spring return. Maximum weight of connecting mechanism: 0.5 lb.

Figure 17

Counterweight holds contacts closed. When the hook reaches the upper limit of its travel, it raises the counterweight and the weighted lever operates the contacts. When the hook is lowered the contacts are reset.

Figure 18

Similar to Figure 1 except lever is on left side.

Figure 19

Similar to Figures 5 and 6 except contacts are arranged for maintained operation. Contacts are actuated when lever is operated in direction shown. Contacts are restored when lever is operated in reverse direction.

Figure 20

Similar to Figures 2 and 3 except contacts are arranged for sequential operation in either direction. Operation is as follows:

Circuit 1 opens at 14°,
 Circuit 2 closes at 45°,
 Total travel is 55°.

Limit Switches

801

General Purpose

Contact Arrangements and Ratings



AC [3 A, 120V
1.5 A, 240V
0.75 A, 480V
0.6 A, 600V

DC [1.1 A, 115V
0.55 A, 230V
0.2 A, 550V

Light Duty

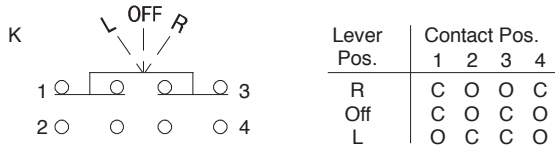
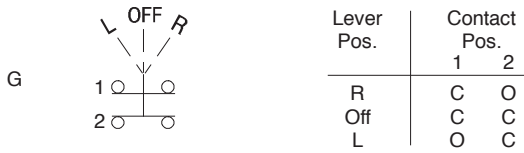
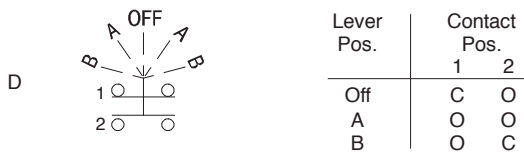
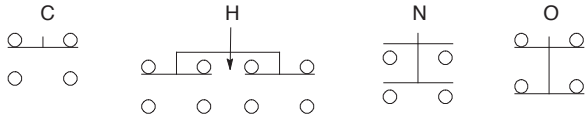

AC [6A, 120V
3A, 240V
1.5A, 480V
1.2A, 600V

DC [2.2A, 115V
1.1A, 230V
0.4A, 550V

Standard Duty

Ambient Temperature Range

0...+40°C (+32...+104°F) minimum temperature based on the absence of freezing moisture or water.

Approximate Dimensions [mm (in.)]

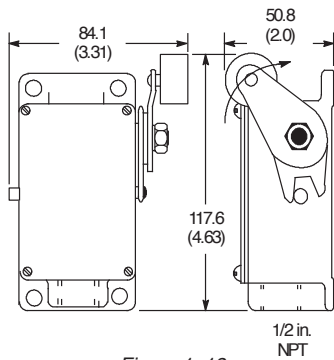

Figure 1, 18

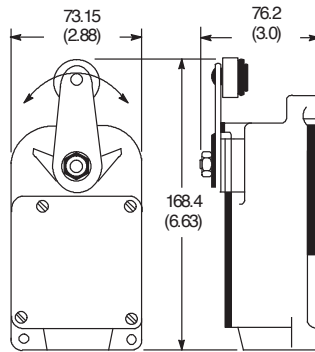

Figure 2, 3, 20

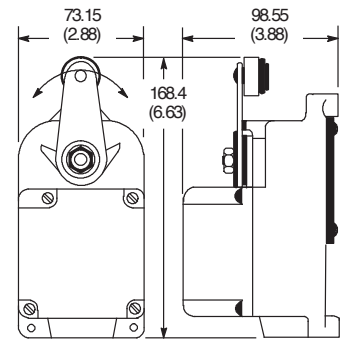

Figure 4

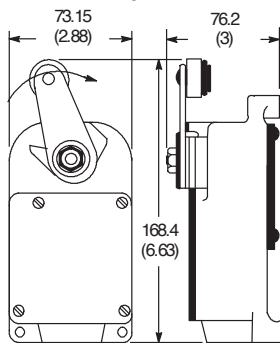

Figure 5, 6, 19

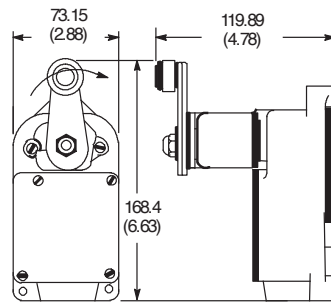

Figure 7, 8

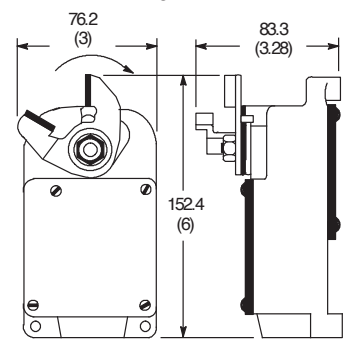

Figure 9

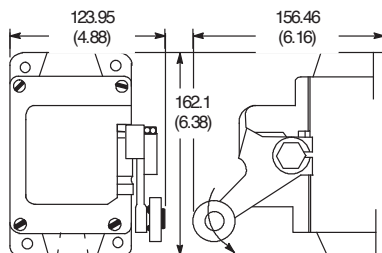

Figure 10, 11

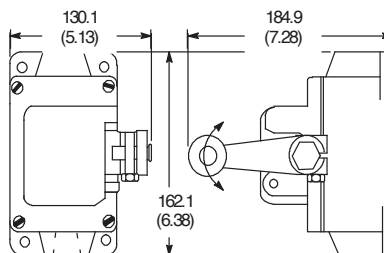

Figure 12

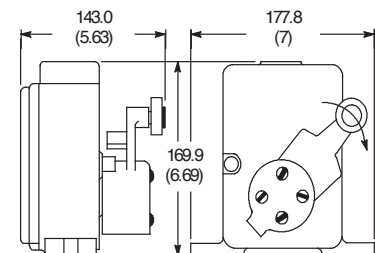

Figure 13

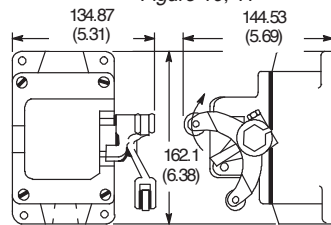

Figure 14

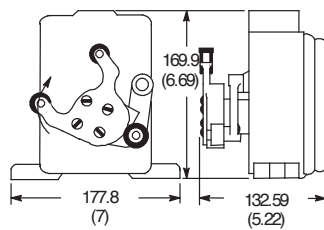

Figure 15

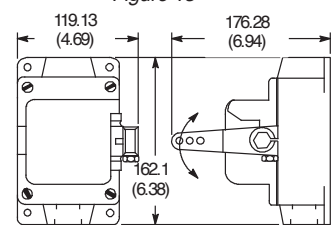

Figure 16

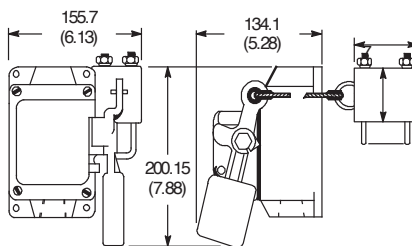

Figure 17

Product Selection

Type of Lever	Contact Operation	Housing Style	Contact Type & Rating ①	Force to Operate (Max.)	Travel to Operate Contacts (Nominal)	Over Travel (Min.)	Cat. No.
NEMA Type 1 Enclosure							
Roller	Slow Action Spring Return	Figure 1	A	15.58 N (3.5 lb)	8_	3_	801-ASA11
			B	15.58 N (3.5 lb)	3_	8_	801-ASB11
		Figure 2	A	15.58 N (3.5 lb)	8_	3_	801-ASA12
			C	10.0 N (2.25 lb)	30_	25_	801-ASC17
			D	10.0 N (2.25 lb)	See Figure 20 ②	See Figure 20 ②	801-ASD17
			F	10.0 N (2.25 lb)	25_	30_	801-ASF17
	Snap Action Spring Return	Figure 2	G	10.0 N (2.25 lb)	15_	40_	801-ASG17
			C	22.25 N (5.0 lb)	25_	30_	801-ASC21
			C	37.82 N (8.5 lb)	9_	40_	801-ASC21X
			N	22.25 N (5.0 lb)	25_	30_	801-ASN21
			N	37.82 N (8.5 lb)	9_	40_	801-ASN21X
			O	22.25 N (5.0 lb)	25_	30_	801-ASC21
			O	37.82 N (8.5 lb)	9_	40_	801-ASC21X
			C	10.0 N (2.25 lb)	30_	25_	801-ASC313
		Figure 4	H	22.25 N (5.0 lb)	30_	20_	801-ASH22
			H	31.15 N (7.0 lb)	10_	43_	801-ASH26X
		Figure 3	C	17.8 N (4.0 lb)	25_	30_	801-ASC25
			C	31.15 N (7.0 lb)	9_	44_	801-ASC25X
			N	17.8 N (4.0 lb)	25_	30_	801-ASN25
			N	28.92 N (6.5 lb)	9_	44_	801-ASN25X
Figure 5	C	22.25 N (5.0 lb)	25_	15_	801-ASC27		
	C	17.8 N (4.0 lb)	25_	15_	801-ASC29		
Ratchet Type Maintained	Figure 7	C	28.92 N (6.5 lb)	68_	12_	801-ASC218	
	Figure 8	C	22.25 N (5.0 lb)	68_	12_	801-ASC220	
Snap Action Maintained	Figure 19	C	10.0 N (2.25 lb)	38_	24_	801-AMC211	
Fork	Snap Action Maintained	Figure 9	C	15.58 N (3.5 lb)	20.6 mm (0.81 in.)	—	801-CMC21
Rod or Chain			C	10.0 N (2.25 lb)	20.6 mm (0.81 in.)	20.6 mm (0.81 in.)	801-DMC21
Stroke			C	20.0 N (4.5 lb)	14.2 mm (0.56 in.)	—	801-EMC21
NEMA Type 4 Enclosure (For Indoor Use)							
Roller	Slow Action Spring Return	Figure 10	C	27.81 N (6.25 lb)	26_	4_	801-ASC1411
			H	27.81 N (6.25 lb)	26_	4_	801-ASH1411
		Figure 11	C	17.8 N (4.0 lb)	26_	4_	801-ASC1415
		Figure 12	K	17.8 N (4.0 lb)	26_	4_	801-ASK1421
	Snap Action Spring Return	Figure 13	C	17.8 N (4.0 lb)	26.5_	6_	801-ASC2426
Fork	Slow Action Maintained	Figure 14	C	31.15 N (7.0 lb)	31.8 mm (1.25 in.)	—	801-CMC144
	Snap Action Maintained	Figure 15	C	28.92 N (6.5 lb)	38.1 mm (1.5 in.)	—	801-CMC2411
Rod or Chain	Slow Action	Figure 16	K	13.35 N (3.0 lb)	26_	4_	801-DSK145
Weight	Spring Return	Figure 17	C	22.25 N (5.0 lb)	26_	4_	801-FSC148 ③
NEMA Type 7 & 9 Enclosure							
Roller	Slow Action Spring Return	Figure 10	C	27.81 N (6.25 lb)	26_	4_	801-ASC1711
			H	27.81 N (6.25 lb)	26_	4_	801-ASH1711
		Figure 11	C	17.8 N (4.0 lb)	26_	4_	801-ASC1715
		Figure 12	K	17.8 N (4.0 lb)	26_	4_	801-ASK1721
	Snap Action Spring Return	Figure 13	C	17.8 N (4.0 lb)	26.5_	6_	801-ASC2726
Fork	Snap Action Maintained	Figure 15	C	28.92 N (6.5 lb)	38.1 mm (1.5 in.)	—	801-CMC2711

① See table on page 5-10.

② See Figure 20 on page 5-9.

③ The following replacement parts are available: combination lever/weight = B7391, counterweight = Z1997, counterweight cable = B37939.