



Visualisation; Diagnostics

Easy to Configure

Programming IEC 61131-3

Rapid Installation

PZA

PILZ
THE SPIRIT OF SAFETY

► Safe monitoring relays

This document is the original document.

All rights to this documentation are reserved by Pilz GmbH & Co. KG. Copies may be made for the user's internal purposes. Suggestions and comments for improving this documentation will be gratefully received.

Source code from third-party manufacturers or open source software has been used for some components. The relevant licence information is available on the Internet on the Pilz homepage.

Pilz®, PIT®, PMI®, PNOZ®, Primo®, PSEN®, PSS®, PVIS®, SafetyBUS p®, SafetyEYE®, SafetyNET p®, the spirit of safety® are registered and protected trademarks of Pilz GmbH & Co. KG in some countries.



SD means Secure Digital

Introduction	4
Validity of documentation	4
Using the documentation	4
Definition of symbols	4
Safety	5
Intended use	5
Safety regulations	5
Safety assessment	5
Use of qualified personnel	6
Warranty and liability	6
Disposal	6
For your safety	6
Unit features	7
Safety features	7
Block diagram/terminal configuration	7
Types: AC	7
Types: DC	8
Function description	8
Installation	9
Wiring	9
Preparing for Operation	10
Operation	10
Status indicators	10
Faults – Interference	11
Dimensions in mm	11
Technical details	11
Safety characteristic data	28
Supplementary data	29
Service life graph	29
Order reference	30
EC declaration of conformity	30

Introduction

Validity of documentation

This documentation is valid for the product PZA. It is valid until new documentation is published.

This operating manual explains the function and operation, describes the installation and provides guidelines on how to connect the product.

Using the documentation

This document is intended for instruction. Only install and commission the product if you have read and understood this document. The document should be retained for future reference.

Definition of symbols

Information that is particularly important is identified as follows:



DANGER!

This warning must be heeded! It warns of a hazardous situation that poses an immediate threat of serious injury and death and indicates preventive measures that can be taken.



WARNING!

This warning must be heeded! It warns of a hazardous situation that could lead to serious injury and death and indicates preventive measures that can be taken.



CAUTION!

This refers to a hazard that can lead to a less serious or minor injury plus material damage, and also provides information on preventive measures that can be taken.



NOTICE

This describes a situation in which the product or devices could be damaged and also provides information on preventive measures that can be taken. It also highlights areas within the text that are of particular importance.

**INFORMATION**

This gives advice on applications and provides information on special features.

Safety**Intended use**

The unit operates as a time delay device with delay-on energisation

- ▶ In accordance with EN ISO 14119 (release with delay through timer)
- ▶ in safety circuits in accordance with VDE 0113-1 and IEC 60204-1

The unit is designed for use with

- ▶ Safety relays from the PNOZ series
- ▶ safety gate monitors from the PST series

The category that can be achieved in accordance with EN ISO 13849-1 depends on the category of the base unit. PZA may not exceed this.

The following is deemed improper use in particular

- ▶ Any component, technical or electrical modification to the product,
- ▶ Use of the product outside the areas described in this manual,
- ▶ Use of the product outside the technical details (see Technical details).

**NOTICE****EMC-compliant electrical installation**

The product is designed for use in an industrial environment. The product may cause interference if installed in other environments. If installed in other environments, measures should be taken to comply with the applicable standards and directives for the respective installation site with regard to interference.

Safety regulations**Safety assessment**

Before using a device it is necessary to perform a safety assessment in accordance with the Machinery Directive.

Functional safety is guaranteed for the product as a single component. However, this does not guarantee the functional safety of the overall plant/machine. In order to achieve the required safety level for the overall plant/machine, define the safety requirements for the plant/machine and then define how these must be implemented from a technical and organisational standpoint.

Use of qualified personnel

The products may only be assembled, installed, programmed, commissioned, operated, maintained and decommissioned by competent persons.

A competent person is a qualified and knowledgeable person who, because of their training, experience and current professional activity, has the specialist knowledge required. To be able to inspect, assess and operate devices, systems and machines, the person has to be informed of the state of the art and the applicable national, European and international laws, directives and standards.

It is the company's responsibility only to employ personnel who

- ▶ Are familiar with the basic regulations concerning health and safety / accident prevention,
- ▶ Have read and understood the information provided in the section entitled Safety
- ▶ Have a good knowledge of the generic and specialist standards applicable to the specific application.

Warranty and liability

All claims to warranty and liability will be rendered invalid if

- ▶ The product was used contrary to the purpose for which it is intended,
- ▶ Damage can be attributed to not having followed the guidelines in the manual,
- ▶ Operating personnel are not suitably qualified,
- ▶ Any type of modification has been made (e.g. exchanging components on the PCB boards, soldering work etc.).

Disposal

- ▶ In safety-related applications, please comply with the mission time T_M in the safety-related characteristic data.
- ▶ When decommissioning, please comply with local regulations regarding the disposal of electronic devices (e.g. Electrical and Electronic Equipment Act).

For your safety

The unit meets all the necessary conditions for safe operation. However, please note the following:

- ▶ Note for overvoltage category III: If voltages higher than low voltage (>50 VAC or >120 VDC) are present on the unit, connected control elements and sensors must have a rated insulation voltage of at least 250 V.

Unit features

- ▶ Positive-guided relay outputs:
 - 1 safety contact (N/O), delay-on energisation
 - 2 auxiliary contacts (N/C), delay-on energisation
- ▶ LED display for:
 - Supply voltage
 - Switch state safety output
- ▶ 12 time values, set via rotary switch
- ▶ Feedback loop for monitoring external contactors
- ▶ See order reference for unit types

Safety features

The relay meets the following safety requirements:

- ▶ The circuit is internally redundant with built-in self-monitoring.
- ▶ The safety device remains effective in the case of a component failure.
- ▶ The correct opening and closing of the safety device relays is tested automatically in each on-off cycle.

Block diagram/terminal configuration

Types: AC

- ▶ U_B : 24 V AC; Order no. 774020, 774031
- ▶ U_B : 110 - 120 VAC; Order no. 774023, 774035
- ▶ U_B : 230 V AC; Order no. 774026, 774038, 774040

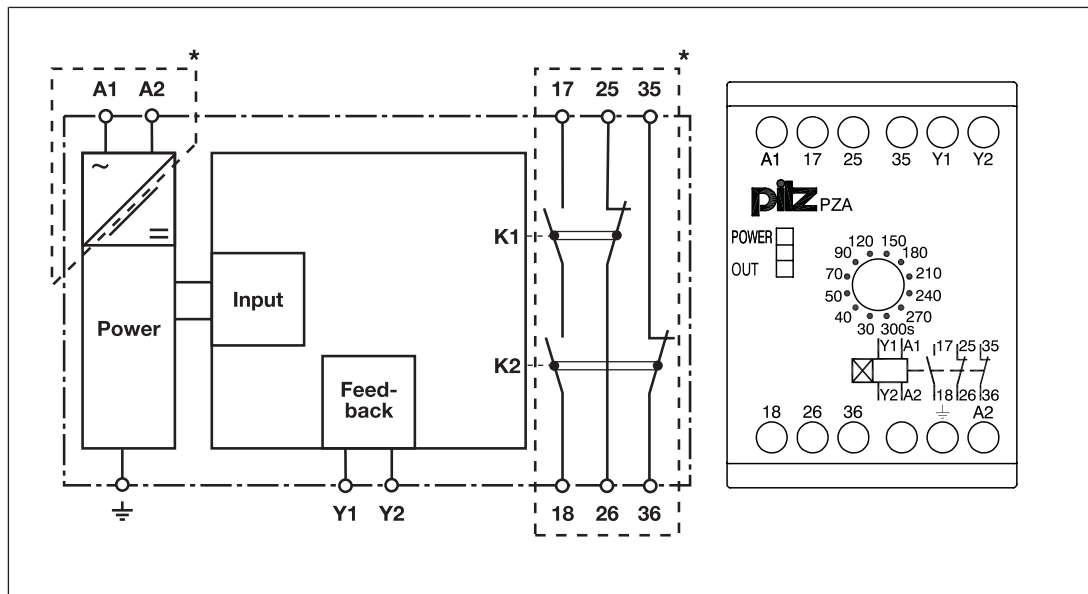

*Insulation between the non-marked area and the relay contacts: Basic insulation (over-voltage category III), Protective separation (overvoltage category II)

Types: DC

- ▶ U_B : 24 V DC; Order no. 774028, 774029, 774030, 774041

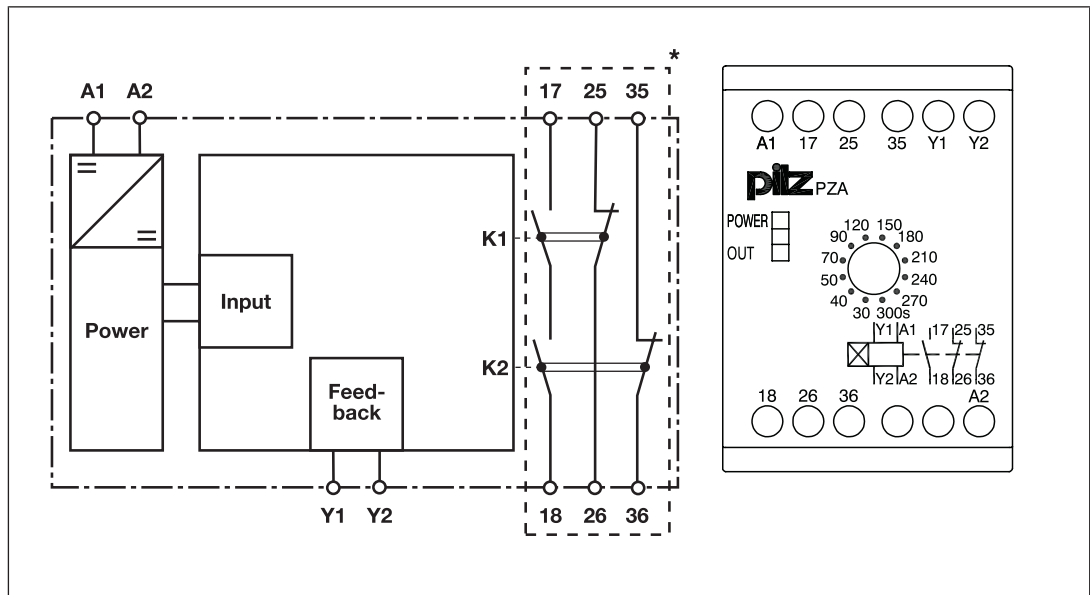

*Insulation between the non-marked area and the relay contacts: Basic insulation (over-voltage category III), Protective separation (overvoltage category II)

Function description

The unit is ready for operation when the feedback loop Y1-Y2 is closed.

- ▶ Input circuit closed (supply voltage is present)
 - "POWER" LED is illuminated. The safety contact 17-18 is closed and the auxiliary contacts 25-26, 35-36 will open once the set delay-on energisation has elapsed. The "OUT" LED is lit.
- ▶ The input circuit is opened (supply voltage is interrupted)
 - The safety contact 17-18 is redundantly opened and the auxiliary contacts 25-26, 35-36 will close. The LEDs "POWER" and "OUT" go out.

The delay time can be set in 12 stages on the front of the unit using a screwdriver.

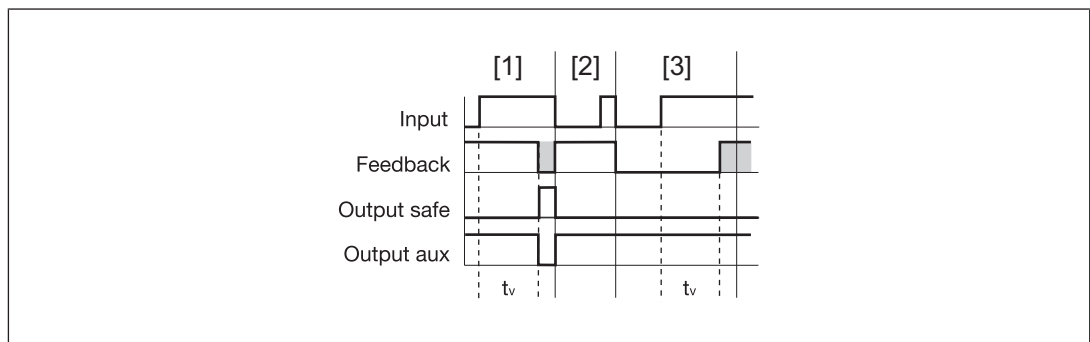

Legend

- ▶ Input: Input circuit
- ▶ Feedback: Feedback loop
- ▶ Output safe: Safety contact
- ▶ Output aux: Auxiliary contacts

- ▶ t_v : Delay time

[1]: Normal operating cycle

[2]: Fault: Input circuit opened too early

[3]: Fault: Feedback loop closed too late after t_v elapsed



NOTICE

At the earliest the safety contacts close after the set delay time - 15% of the set value, even in the case of a component failure.

Installation

- ▶ The unit should be installed in a control cabinet with a protection type of at least IP54.
- ▶ Use the notch on the rear of the unit to attach it to a DIN rail (35 mm).
- ▶ When installed vertically: Secure the unit by using a fixing element (e.g. retaining bracket or end angle).

Wiring

Please note:

- ▶ Information given in the "Technical details" must be followed.
- ▶ The output 17-18 is a safety contact, outputs 25-26, 35-36 are auxiliary contacts (e.g. for display).
- ▶ Do **not** use auxiliary contacts 25-26, 35-36 for safety circuits!
- ▶ To prevent contact welding, a fuse should be connected before the output contacts (see Technical details).
- ▶ Do not connect undesignated terminals.
- ▶ Calculation of the max. cable length l_{max} in the input circuit:

$$l_{max} = \frac{R_{lmax}}{R_l / km}$$

R_{lmax} = max. overall cable resistance (see Technical details)

R_l / km = cable resistance/km

- ▶ Use copper wire that can withstand 60/75 °C.
- ▶ Sufficient fuse protection must be provided on all output contacts with capacitive and inductive loads.
- ▶ Do not switch low currents using contacts that have been used previously with high currents.
- ▶ Ensure the wiring and EMC requirements of EN 60204-1 are met.
- ▶ On 24 VDC devices:
The power supply must comply with the regulations for extra low voltages with protective electrical separation (SELV, PELV) in accordance with VDE 0100, Part 410.
- ▶ In devices for 24 V DC shorts between the input circuit and feedback loop or earth faults in the feedback loop can damage the unit. We recommend the use of a short circuit-proof supply voltage with current limitation.

Preparing for Operation

Supply voltage	AC	DC
Input circuit is driven by connecting U_B		
Feedback loop	Without feedback loop monitoring	With feedback loop monitoring
Link or contacts from external contactors		

Operation

When the relay outputs are switched on, the mechanical contact on the relay cannot be tested automatically. Depending on the operational environment, measures to detect the non-opening of switching elements may be required under some circumstances.

When the product is used in accordance with the European Machinery Directive, a check must be carried out to ensure that the safety contacts on the relay outputs open correctly. Open the safety contacts (switch off output) and start the device again, so that the internal diagnostics can check that the safety contacts open correctly

- ▶ for SIL CL 3/PL d at least 1x per month
- ▶ for SIL CL 1/PL c at least 1x per year



NOTICE

The safety function should be checked after initial commissioning and each time the plant/machine is changed. The safety functions may only be checked by qualified personnel.

Status indicators

LEDs indicate the status and errors during operation:



LED on



POWER

Supply voltage is present.



OUT

Safety contact is closed.

Faults – Interference

- ▶ LED "POWER" does not light: Short circuit or no supply voltage.
- ▶ If an error occurs in the time relay the safety contact remains open and the auxiliary contacts remain closed. The time value goes toward infinity.

Dimensions in mm

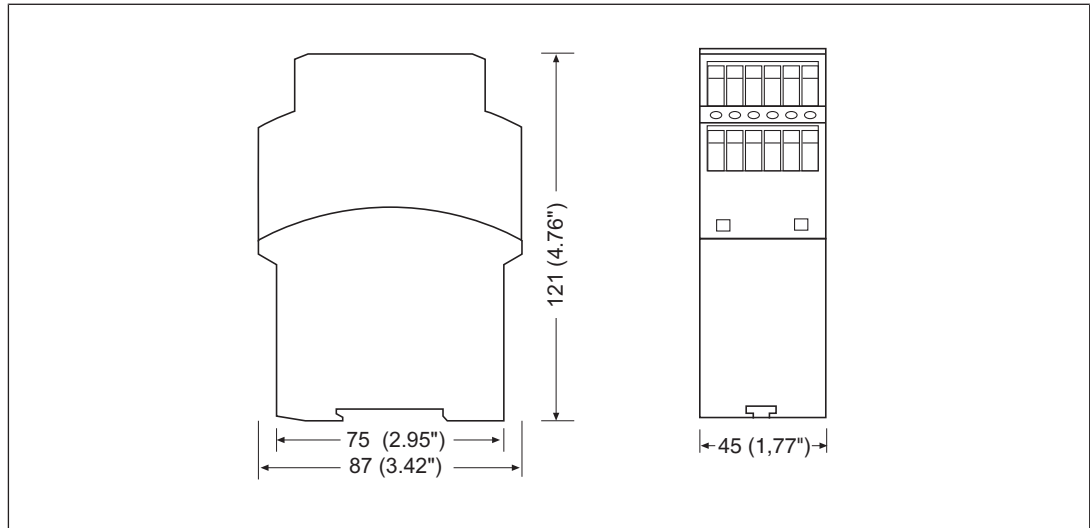

Technical details

Order no. 774030 – 774035

See below for more order numbers

General	774030	774031	774035
Approvals	CCC, CE, EAC (Eurasian), TÜV, cULus Listed	CCC, CE, EAC (Eurasian), TÜV, cULus Listed	CCC, CE, EAC (Eurasian), TÜV, cULus Listed
Electrical data	774030	774031	774035
Supply voltage			
Voltage	24 V	24 V	110 - 120 V
Kind	DC	AC	AC
Voltage tolerance	-15 %/+10 %	-15 %/+10 %	-15 %/+10 %
Output of external power supply (AC)	–	4,5 VA	4,5 VA
Output of external power supply (DC)	3 W	–	–
Frequency range AC	–	50 - 60 Hz	50 - 60 Hz
Residual ripple DC	10 %	–	–
Duty cycle	100 %	100 %	100 %
External unit fuse protection F1 min.	1 A	1 A	1 A
External unit fuse protection F1 max.	Max. conductor cross section	Max. conductor cross section	Max. conductor cross section

Inputs	774030	774031	774035
Voltage at			
Feedback loop DC	24 V	24 V	24 V
Current at			
Feedback loop DC	50 mA	50 mA	50 mA
Relay outputs	774030	774031	774035
Number of output con- tacts			
Safety contacts (N/O), delayed	1	1	1
Auxiliary contacts (N/ C), delayed	2	2	2
Max. short circuit current IK	1 kA	1 kA	1 kA
Utilisation category			
In accordance with the standard	EN 60947-4-1	EN 60947-4-1	EN 60947-4-1
Utilisation category of safety contacts			
AC1 at	240 V	240 V	240 V
Min. current	0,01 A	0,01 A	0,01 A
Max. current	6 A	6 A	6 A
Max. power	1500 VA	1500 VA	1500 VA
DC1 at	24 V	24 V	24 V
Min. current	0,01 A	0,01 A	0,01 A
Max. current	6 A	6 A	6 A
Max. power	150 W	150 W	150 W
Utilisation category of auxiliary contacts			
AC1 at	240 V	240 V	240 V
Min. current	0,01 A	0,01 A	0,01 A
Max. current	6 A	6 A	6 A
Max. power	1500 VA	1500 VA	1500 VA
DC1 at	24 V	24 V	24 V
Min. current	0,01 A	0,01 A	0,01 A
Max. current	6 A	6 A	6 A
Max. power	150 W	150 W	150 W
Utilisation category			
In accordance with the standard	EN 60947-5-1	EN 60947-5-1	EN 60947-5-1
Utilisation category of safety contacts			
AC15 at	230 V	230 V	230 V
Max. current	4 A	4 A	4 A
DC13 (6 cycles/min) at	24 V	24 V	24 V
Max. current	3 A	3 A	3 A

Relay outputs	774030	774031	774035
Utilisation category of auxiliary contacts			
AC15 at	230 V	230 V	230 V
Max. current	4 A	4 A	4 A
DC13 (6 cycles/min) at	24 V	24 V	24 V
Max. current	3 A	3 A	3 A
Utilisation category in accordance with UL			
Voltage	240 V AC G. P.	240 V AC G. P.	240 V AC G. P.
With current	6 A	6 A	6 A
Voltage	24 V DC Resistive	24 V DC Resistive	24 V DC Resistive
With current	5 A	5 A	5 A
Pilot Duty	B300, R300	B300, R300	B300, R300
External contact fuse protection, safety contacts			
In accordance with the standard	EN 60947-5-1	EN 60947-5-1	EN 60947-5-1
Max. melting integral	240 A²s	240 A²s	240 A²s
Blow-out fuse, quick	6 A	6 A	6 A
Blow-out fuse, slow	4 A	4 A	4 A
Blow-out fuse, gG	6 A	6 A	6 A
Circuit breaker 24V AC/DC, characteristic B/C	4 A	4 A	4 A
External contact fuse protection, auxiliary contacts			
Max. melting integral	240 A²s	240 A²s	240 A²s
Blow-out fuse, quick	6 A	6 A	6 A
Blow-out fuse, slow	4 A	4 A	4 A
Blow-out fuse, gG	6 A	6 A	6 A
Circuit breaker 24 V AC/DC, characteristic B/C	4 A	4 A	4 A
Conventional thermal current	6 A	6 A	6 A
Contact material	AgSnO₂ + 0,2 µm Au	AgSnO₂ + 0,2 µm Au	AgSnO₂ + 0,2 µm Au
Times	774030	774031	774035
Delay-on de-energisation			
With power failure typ.	40 ms	40 ms	40 ms
With power failure max.	70 ms	70 ms	70 ms
Recovery time at max. switching frequency 1/s			
After power failure	80 ms	80 ms	80 ms
Delay time tv	3 s, 4 s, 5 s, 7 s, 9 s, 12 s, 15 s, 18 s, 21 s, 24 s, 27 s, 30 s	3 s, 4 s, 5 s, 7 s, 9 s, 12 s, 15 s, 18 s, 21 s, 24 s, 27 s, 30 s	3 s, 4 s, 5 s, 7 s, 9 s, 12 s, 15 s, 18 s, 21 s, 24 s, 27 s, 30 s
Time accuracy	-15% / +15% +50 ms	-15% / +15% +50 ms	-15% / +15% +50 ms
Repetition accuracy	2 %	2 %	2 %

Times	774030	774031	774035
Min. delay time (operating mode delay-on energisation)	tv - 15 %	tv - 15 %	tv - 15 %
Environmental data	774030	774031	774035
Climatic suitability	EN 60068-2-78	EN 60068-2-78	EN 60068-2-78
Ambient temperature			
Temperature range	-10 - 55 °C	-10 - 55 °C	-10 - 55 °C
Storage temperature			
Temperature range	-40 - 85 °C	-40 - 85 °C	-40 - 85 °C
Climatic suitability			
Humidity	93 % r. h. at 40 °C	93 % r. h. at 40 °C	93 % r. h. at 40 °C
Condensation during operation	Not permitted	Not permitted	Not permitted
EMC	EN 60947-5-1, EN 61000-6-2, EN 61326-3-1	EN 60947-5-1, EN 61000-6-2, EN 61326-3-1	EN 60947-5-1, EN 61000-6-2, EN 61326-3-1
Vibration			
In accordance with the standard	EN 60068-2-6	EN 60068-2-6	EN 60068-2-6
Frequency	10 - 55 Hz	10 - 55 Hz	10 - 55 Hz
Amplitude	0,35 mm	0,35 mm	0,35 mm
Airgap creepage			
In accordance with the standard	EN 60947-1	EN 60947-1	EN 60947-1
Overvoltage category	III / II	III / II	III / II
Pollution degree	2	2	2
Rated insulation voltage	250 V	250 V	250 V
Rated impulse withstand voltage	4 kV	4 kV	4 kV
Protection type			
Housing	IP40	IP40	IP40
Terminals	IP20	IP20	IP20
Mounting area (e.g. control cabinet)	IP54	IP54	IP54
Mechanical data	774030	774031	774035
Mounting position	Any	Any	Any
Mechanical life	10,000,000 cycles	10,000,000 cycles	10,000,000 cycles
Material			
Bottom	PPO UL 94 V0	PPO UL 94 V0	PPO UL 94 V0
Front	ABS UL 94 V0	ABS UL 94 V0	ABS UL 94 V0
Top	PPO UL 94 V0	PPO UL 94 V0	PPO UL 94 V0
Connection type	Screw terminal	Screw terminal	Screw terminal
Mounting type	Fixed	Fixed	Fixed

Mechanical data	774030	774031	774035
Conductor cross section with screw terminals			
1 core flexible	0,2 - 4 mm ² , 24 - 10 AWG	0,2 - 4 mm ² , 24 - 10 AWG	0,2 - 4 mm ² , 24 - 10 AWG
2 core with the same cross section, flexible with crimp connectors, no plastic sleeve	0,2 - 2,5 mm ² , 24 - 14 AWG	0,2 - 2,5 mm ² , 24 - 14 AWG	0,2 - 2,5 mm ² , 24 - 14 AWG
2 core with the same cross section, flexible without crimp connectors or with TWIN crimp connectors	0,2 - 2,5 mm ² , 24 - 14 AWG	0,2 - 2,5 mm ² , 24 - 14 AWG	0,2 - 2,5 mm ² , 24 - 14 AWG
Torque setting with screw terminals	0,6 Nm	0,6 Nm	0,6 Nm
Dimensions			
Height	87 mm	87 mm	87 mm
Width	45 mm	45 mm	45 mm
Depth	121 mm	121 mm	121 mm
Weight	255 g	350 g	350 g

Order no. 774038 – 774041

General	774038	774040	774041
Approvals	CCC, CE, EAC (Eurasian), TÜV, cULus Listed	CCC, CE, EAC (Eurasian), TÜV, cULus Listed	CCC, CE, EAC (Eurasian), TÜV, cULus Listed
Electrical data	774038	774040	774041
Supply voltage			
Voltage	230 V	230 V	24 V
Kind	AC	AC	DC
Voltage tolerance	-15 %/+10 %	-15 %/+10 %	-15 %/+10 %
Output of external power supply (AC)	4,5 VA	4,5 VA	–
Output of external power supply (DC)	–	–	3 W
Frequency range AC	50 - 60 Hz	50 - 60 Hz	–
Residual ripple DC	–	–	10 %
Duty cycle	100 %	100 %	100 %
External unit fuse protection F1 min.	1 A	1 A	1 A
External unit fuse protection F1 max.	Max. conductor cross section	Max. conductor cross section	Max. conductor cross section
Inputs	774038	774040	774041
Voltage at			
Feedback loop DC	24 V	24 V	24 V
Current at			
Feedback loop DC	50 mA	50 mA	50 mA

Relay outputs	774038	774040	774041
Number of output contacts			
Safety contacts (N/O), delayed	1	1	1
Auxiliary contacts (N/C), delayed	2	2	2
Max. short circuit current IK	1 kA	1 kA	1 kA
Utilisation category			
In accordance with the standard	EN 60947-4-1	EN 60947-4-1	EN 60947-4-1
Utilisation category of safety contacts			
AC1 at	240 V	240 V	240 V
Min. current	0,01 A	0,01 A	0,01 A
Max. current	6 A	6 A	6 A
Max. power	1500 VA	1500 VA	1500 VA
DC1 at	24 V	24 V	24 V
Min. current	0,01 A	0,01 A	0,01 A
Max. current	6 A	6 A	6 A
Max. power	150 W	150 W	150 W
Utilisation category of auxiliary contacts			
AC1 at	240 V	240 V	240 V
Min. current	0,01 A	0,01 A	0,01 A
Max. current	6 A	6 A	6 A
Max. power	1500 VA	1500 VA	1500 VA
DC1 at	24 V	24 V	24 V
Min. current	0,01 A	0,01 A	0,01 A
Max. current	6 A	6 A	6 A
Max. power	150 W	150 W	150 W
Utilisation category			
In accordance with the standard	EN 60947-5-1	EN 60947-5-1	EN 60947-5-1
Utilisation category of safety contacts			
AC15 at	230 V	230 V	230 V
Max. current	4 A	4 A	4 A
DC13 (6 cycles/min) at	24 V	24 V	24 V
Max. current	3 A	3 A	3 A
Utilisation category of auxiliary contacts			
AC15 at	230 V	230 V	230 V
Max. current	4 A	4 A	4 A
DC13 (6 cycles/min) at	24 V	24 V	24 V
Max. current	3 A	3 A	3 A

Relay outputs	774038	774040	774041
Utilisation category in accordance with UL			
Voltage	240 V AC G. P.	240 V AC G. P.	240 V AC G. P.
With current	6 A	6 A	6 A
Voltage	24 V DC Resistive	24 V DC Resistive	24 V DC Resistive
With current	5 A	5 A	5 A
Pilot Duty	B300, R300	B300, R300	B300, R300
External contact fuse protection, safety contacts			
In accordance with the standard	EN 60947-5-1	EN 60947-5-1	EN 60947-5-1
Max. melting integral	240 A²s	240 A²s	240 A²s
Blow-out fuse, quick	6 A	6 A	6 A
Blow-out fuse, slow	4 A	4 A	4 A
Blow-out fuse, gG	6 A	6 A	6 A
Circuit breaker 24V AC/DC, characteristic B/C	4 A	4 A	4 A
External contact fuse protection, auxiliary contacts			
Max. melting integral	240 A²s	240 A²s	240 A²s
Blow-out fuse, quick	6 A	6 A	6 A
Blow-out fuse, slow	4 A	4 A	4 A
Blow-out fuse, gG	6 A	6 A	6 A
Circuit breaker 24 V AC/DC, characteristic B/C	4 A	4 A	4 A
Conventional thermal current	6 A	6 A	6 A
Contact material	AgSnO₂ + 0,2 µm Au	AgSnO₂ + 0,2 µm Au	AgSnO₂ + 0,2 µm Au
Times	774038	774040	774041
Delay-on de-energisation			
With power failure typ.	40 ms	40 ms	40 ms
With power failure max.	70 ms	70 ms	70 ms
Recovery time at max. switching frequency 1/s			
After power failure	80 ms	80 ms	80 ms
Delay time tv	0,3 s, 0,4 s, 0,5 s, 0,7 s, 0,9 s, 1,2 s, 1,5 s, 1,8 s, 2,1 s, 2,4 s, 2,7 s, 3 s	3 s, 4 s, 5 s, 7 s, 9 s, 12 s, 15 s, 18 s, 21 s, 24 s, 27 s, 30 s	0,3 s, 0,4 s, 0,5 s, 0,7 s, 0,9 s, 1,2 s, 1,5 s, 1,8 s, 2,1 s, 2,4 s, 2,7 s, 3 s
Time accuracy	-15% / +15% +50 ms	-15% / +15% +50 ms	-15% / +15% +50 ms
Repetition accuracy	2 %	2 %	2 %
Min. delay time (operating mode delay-on energisation)	tv - 15 %	tv - 15 %	tv - 15 %
Environmental data	774038	774040	774041
Climatic suitability	EN 60068-2-78	EN 60068-2-78	EN 60068-2-78

Environmental data	774038	774040	774041
Ambient temperature			
Temperature range	-10 - 55 °C	-10 - 55 °C	-10 - 55 °C
Storage temperature			
Temperature range	-40 - 85 °C	-40 - 85 °C	-40 - 85 °C
Climatic suitability			
Humidity	93 % r. h. at 40 °C	93 % r. h. at 40 °C	93 % r. h. at 40 °C
Condensation during operation	Not permitted	Not permitted	Not permitted
EMC	EN 60947-5-1, EN 61000-6-2, EN 61326-3-1	EN 60947-5-1, EN 61000-6-2, EN 61326-3-1	EN 60947-5-1, EN 61000-6-2, EN 61326-3-1
Vibration			
In accordance with the standard	EN 60068-2-6	EN 60068-2-6	EN 60068-2-6
Frequency	10 - 55 Hz	10 - 55 Hz	10 - 55 Hz
Amplitude	0,35 mm	0,35 mm	0,35 mm
Airgap creepage			
In accordance with the standard	EN 60947-1	EN 60947-1	EN 60947-1
Overvoltage category	III / II	III / II	III / II
Pollution degree	2	2	2
Rated insulation voltage	250 V	250 V	250 V
Rated impulse withstand voltage	4 kV	4 kV	4 kV
Protection type			
Housing	IP40	IP40	IP40
Terminals	IP20	IP20	IP20
Mounting area (e.g. control cabinet)	IP54	IP54	IP54
Mechanical data	774038	774040	774041
Mounting position	Any	Any	Any
Mechanical life	10,000,000 cycles	10,000,000 cycles	10,000,000 cycles
Material			
Bottom	PPO UL 94 V0	PPO UL 94 V0	PPO UL 94 V0
Front	ABS UL 94 V0	ABS UL 94 V0	ABS UL 94 V0
Top	PPO UL 94 V0	PPO UL 94 V0	PPO UL 94 V0
Connection type	Screw terminal	Screw terminal	Screw terminal
Mounting type	Fixed	Fixed	Fixed

Mechanical data	774038	774040	774041
Conductor cross section with screw terminals			
1 core flexible	0,2 - 4 mm², 24 - 10 AWG	0,2 - 4 mm², 24 - 10 AWG	0,2 - 4 mm², 24 - 10 AWG
2 core with the same cross section, flexible with crimp connectors, no plastic sleeve	0,2 - 2,5 mm², 24 - 14 AWG	0,2 - 2,5 mm², 24 - 14 AWG	0,2 - 2,5 mm², 24 - 14 AWG
2 core with the same cross section, flexible without crimp connectors or with TWIN crimp connectors	0,2 - 2,5 mm², 24 - 14 AWG	0,2 - 2,5 mm², 24 - 14 AWG	0,2 - 2,5 mm², 24 - 14 AWG
Torque setting with screw terminals	0,6 Nm	0,6 Nm	0,6 Nm
Dimensions			
Height	87 mm	87 mm	87 mm
Width	45 mm	45 mm	45 mm
Depth	121 mm	121 mm	121 mm
Weight	255 g	350 g	255 g

Order no. 774020 – 774026

General	774020	774023	774026
Approvals	CCC, CE, EAC (Eurasian), TÜV, cULus Listed	CCC, CE, EAC (Eurasian), TÜV, cULus Listed	CCC, CE, EAC (Eurasian), TÜV, cULus Listed
Electrical data	774020	774023	774026
Supply voltage			
Voltage	24 V	110 - 120 V	230 V
Kind	AC	AC	AC
Voltage tolerance	-15 %/+10 %	-15 %/+10 %	-15 %/+10 %
Output of external power supply (AC)	4,5 VA	4,5 VA	4,5 VA
Frequency range AC	50 - 60 Hz	50 - 60 Hz	50 - 60 Hz
Duty cycle	100 %	100 %	100 %
External unit fuse protection F1 min.	1 A	1 A	1 A
External unit fuse protection F1 max.	Max. conductor cross section	Max. conductor cross section	Max. conductor cross section
Inputs	774020	774023	774026
Voltage at			
Feedback loop DC	24 V	24 V	24 V
Current at			
Feedback loop DC	50 mA	50 mA	50 mA
Relay outputs	774020	774023	774026
Number of output contacts			
Safety contacts (N/O), delayed	1	1	1
Auxiliary contacts (N/C), delayed	2	2	2
Max. short circuit current IK	1 kA	1 kA	1 kA
Utilisation category			
In accordance with the standard	EN 60947-4-1	EN 60947-4-1	EN 60947-4-1
Utilisation category of safety contacts			
AC1 at	240 V	240 V	240 V
Min. current	0,01 A	0,01 A	0,01 A
Max. current	6 A	6 A	6 A
Max. power	1500 VA	1500 VA	1500 VA
DC1 at	24 V	24 V	24 V
Min. current	0,01 A	0,01 A	0,01 A
Max. current	6 A	6 A	6 A
Max. power	150 W	150 W	150 W

Relay outputs	774020	774023	774026
Utilisation category of auxiliary contacts			
AC1 at	240 V	240 V	240 V
Min. current	0,01 A	0,01 A	0,01 A
Max. current	6 A	6 A	6 A
Max. power	1500 VA	1500 VA	1500 VA
DC1 at	24 V	24 V	24 V
Min. current	0,01 A	0,01 A	0,01 A
Max. current	6 A	6 A	6 A
Max. power	150 W	150 W	150 W
Utilisation category			
In accordance with the standard	EN 60947-5-1	EN 60947-5-1	EN 60947-5-1
Utilisation category of safety contacts			
AC15 at	230 V	230 V	230 V
Max. current	4 A	4 A	4 A
DC13 (6 cycles/min) at	24 V	24 V	24 V
Max. current	3 A	3 A	3 A
Utilisation category of auxiliary contacts			
AC15 at	230 V	230 V	230 V
Max. current	4 A	4 A	4 A
DC13 (6 cycles/min) at	24 V	24 V	24 V
Max. current	3 A	3 A	3 A
Utilisation category in accordance with UL			
Voltage	240 V AC G. P.	240 V AC G. P.	240 V AC G. P.
With current	6 A	6 A	6 A
Voltage	24 V DC Resistive	24 V DC Resistive	24 V DC Resistive
With current	5 A	5 A	5 A
Pilot Duty	B300, R300	B300, R300	B300, R300
External contact fuse protection, safety contacts			
In accordance with the standard	EN 60947-5-1	EN 60947-5-1	EN 60947-5-1
Max. melting integral	240 A²s	240 A²s	240 A²s
Blow-out fuse, quick	6 A	6 A	6 A
Blow-out fuse, slow	4 A	4 A	4 A
Blow-out fuse, gG	6 A	6 A	6 A
Circuit breaker 24V AC/DC, characteristic B/C	4 A	4 A	4 A

Relay outputs	774020	774023	774026
External contact fuse protection, auxiliary contacts			
Max. melting integral	240 A²s	240 A²s	240 A²s
Blow-out fuse, quick	6 A	6 A	6 A
Blow-out fuse, slow	4 A	4 A	4 A
Blow-out fuse, gG	6 A	6 A	6 A
Circuit breaker 24 V AC/DC, characteristic B/C	4 A	4 A	4 A
Conventional thermal current	6 A	6 A	6 A
Contact material	AgSnO₂ + 0,2 µm Au	AgSnO₂ + 0,2 µm Au	AgSnO₂ + 0,2 µm Au
Times	774020	774023	774026
Delay-on de-energisation			
With power failure typ.	40 ms	40 ms	40 ms
With power failure max.	70 ms	70 ms	70 ms
Recovery time at max. switching frequency 1/s			
After power failure	80 ms	80 ms	80 ms
Delay time t _v	30 s, 40 s, 50 s, 70 s, 90 s, 120 s, 150 s, 180 s, 210 s, 240 s, 270 s, 300 s	30 s, 40 s, 50 s, 70 s, 90 s, 120 s, 150 s, 180 s, 210 s, 240 s, 270 s, 300 s	30 s, 40 s, 50 s, 70 s, 90 s, 120 s, 150 s, 180 s, 210 s, 240 s, 270 s, 300 s
Time accuracy	-15% / +15% +50 ms	-15% / +15% +50 ms	-15% / +15% +50 ms
Repetition accuracy	2 %	2 %	2 %
Min. delay time (operating mode delay-on energisation)	t_v - 15 %	t_v - 15 %	t_v - 15 %
Environmental data	774020	774023	774026
Climatic suitability	EN 60068-2-78	EN 60068-2-78	EN 60068-2-78
Ambient temperature			
Temperature range	-10 - 55 °C	-10 - 55 °C	-10 - 55 °C
Storage temperature			
Temperature range	-40 - 85 °C	-40 - 85 °C	-40 - 85 °C
Climatic suitability			
Humidity	93 % r. h. at 40 °C	93 % r. h. at 40 °C	93 % r. h. at 40 °C
Condensation during operation	Not permitted	Not permitted	Not permitted
EMC	EN 60947-5-1, EN 61000-6-2, EN 61326-3-1	EN 60947-5-1, EN 61000-6-2, EN 61326-3-1	EN 60947-5-1, EN 61000-6-2, EN 61326-3-1
Vibration			
In accordance with the standard	EN 60068-2-6	EN 60068-2-6	EN 60068-2-6
Frequency	10 - 55 Hz	10 - 55 Hz	10 - 55 Hz
Amplitude	0,35 mm	0,35 mm	0,35 mm

Environmental data	774020	774023	774026
Airgap creepage			
In accordance with the standard	EN 60947-1	EN 60947-1	EN 60947-1
Overvoltage category	III / II	III / II	III / II
Pollution degree	2	2	2
Rated insulation voltage	250 V	250 V	250 V
Rated impulse withstand voltage	4 kV	4 kV	4 kV
Protection type			
Housing	IP40	IP40	IP40
Terminals	IP20	IP20	IP20
Mounting area (e.g. control cabinet)	IP54	IP54	IP54
Mechanical data	774020	774023	774026
Mounting position	Any	Any	Any
Mechanical life	10,000,000 cycles	10,000,000 cycles	10,000,000 cycles
Material			
Bottom	PPO UL 94 V0	PPO UL 94 V0	PPO UL 94 V0
Front	ABS UL 94 V0	ABS UL 94 V0	ABS UL 94 V0
Top	PPO UL 94 V0	PPO UL 94 V0	PPO UL 94 V0
Connection type	Screw terminal	Screw terminal	Screw terminal
Mounting type	Fixed	Fixed	Fixed
Conductor cross section with screw terminals			
1 core flexible	0,2 - 4 mm², 24 - 10 AWG	0,2 - 4 mm², 24 - 10 AWG	0,2 - 4 mm², 24 - 10 AWG
2 core with the same cross section, flexible with crimp connectors, no plastic sleeve	0,2 - 2,5 mm², 24 - 14 AWG	0,2 - 2,5 mm², 24 - 14 AWG	0,2 - 2,5 mm², 24 - 14 AWG
2 core with the same cross section, flexible without crimp connectors or with TWIN crimp connectors	0,2 - 2,5 mm², 24 - 14 AWG	0,2 - 2,5 mm², 24 - 14 AWG	0,2 - 2,5 mm², 24 - 14 AWG
Torque setting with screw terminals	0,6 Nm	0,6 Nm	0,6 Nm
Dimensions			
Height	87 mm	87 mm	87 mm
Width	45 mm	45 mm	45 mm
Depth	121 mm	121 mm	121 mm
Weight	255 g	350 g	350 g

Order no. 774028 – 774029

General	774028	774029
Approvals	CCC, CE, EAC (Eurasian), TÜV, cULus Listed	CCC, CE, EAC (Eurasian), TÜV, cULus Listed
Electrical data	774028	774029
Supply voltage		
Voltage	24 V	24 V
Kind	DC	DC
Voltage tolerance	-15 %/+10 %	-15 %/+10 %
Output of external power supply (DC)	3 W	3 W
Residual ripple DC	10 %	10 %
Duty cycle	100 %	100 %
External unit fuse protection F1 min.	1 A	1 A
External unit fuse protection F1 max.	Max. conductor cross section	Max. conductor cross section
Inputs	774028	774029
Voltage at		
Feedback loop DC	24 V	24 V
Current at		
Feedback loop DC	50 mA	50 mA
Relay outputs	774028	774029
Number of output contacts		
Safety contacts (N/O), delayed	1	1
Auxiliary contacts (N/C), delayed	2	2
Max. short circuit current IK	1 kA	1 kA
Utilisation category		
In accordance with the standard	EN 60947-4-1	EN 60947-4-1
Utilisation category of safety contacts		
AC1 at	240 V	240 V
Min. current	0,01 A	0,01 A
Max. current	6 A	6 A
Max. power	1500 VA	1500 VA
DC1 at	24 V	24 V
Min. current	0,01 A	0,01 A
Max. current	6 A	6 A
Max. power	150 W	150 W

Relay outputs	774028	774029
Utilisation category of auxiliary contacts		
AC1 at	240 V	240 V
Min. current	0,01 A	0,01 A
Max. current	6 A	6 A
Max. power	1500 VA	1500 VA
DC1 at	24 V	24 V
Min. current	0,01 A	0,01 A
Max. current	6 A	6 A
Max. power	150 W	150 W
Utilisation category		
In accordance with the standard	EN 60947-5-1	EN 60947-5-1
Utilisation category of safety contacts		
AC15 at	230 V	230 V
Max. current	4 A	4 A
DC13 (6 cycles/min) at	24 V	24 V
Max. current	3 A	3 A
Utilisation category of auxiliary contacts		
AC15 at	230 V	230 V
Max. current	4 A	4 A
DC13 (6 cycles/min) at	24 V	24 V
Max. current	3 A	3 A
Utilisation category in accordance with UL		
Voltage	240 V AC G. P.	240 V AC G. P.
With current	6 A	6 A
Voltage	24 V DC Resistive	24 V DC Resistive
With current	5 A	5 A
Pilot Duty	B300, R300	B300, R300
External contact fuse protection, safety contacts		
In accordance with the standard	EN 60947-5-1	EN 60947-5-1
Max. melting integral	240 A²s	240 A²s
Blow-out fuse, quick	6 A	6 A
Blow-out fuse, slow	4 A	4 A
Blow-out fuse, gG	6 A	6 A
Circuit breaker 24V AC/DC, characteristic B/C	4 A	4 A

Relay outputs	774028	774029
External contact fuse protection, auxiliary contacts		
Max. melting integral	240 A²s	240 A²s
Blow-out fuse, quick	6 A	6 A
Blow-out fuse, slow	4 A	4 A
Blow-out fuse, gG	6 A	6 A
Circuit breaker 24 V AC/DC, characteristic B/C	4 A	4 A
Conventional thermal current	6 A	6 A
Contact material	AgSnO₂ + 0,2 µm Au	AgSnO₂ + 0,2 µm Au
Times	774028	774029
Delay-on de-energisation		
With power failure typ.	40 ms	40 ms
With power failure max.	70 ms	70 ms
Recovery time at max. switching frequency 1/s		
After power failure	80 ms	80 ms
Delay time t _v	60 s, 80 s, 100 s, 140 s, 180 s, 240 s, 300 s, 360 s, 420 s, 480 s, 540 s, 600 s	30 s, 40 s, 50 s, 70 s, 90 s, 120 s, 150 s, 180 s, 210 s, 240 s, 270 s, 300 s
Time accuracy	-15% / +15% +50 ms	-15% / +15% +50 ms
Repetition accuracy	2 %	2 %
Min. delay time (operating mode delay-on energisation)	t_v - 15 %	t_v - 15 %
Environmental data	774028	774029
Climatic suitability	EN 60068-2-78	EN 60068-2-78
Ambient temperature		
Temperature range	-10 - 55 °C	-10 - 55 °C
Storage temperature		
Temperature range	-40 - 85 °C	-40 - 85 °C
Climatic suitability		
Humidity	93 % r. h. at 40 °C	93 % r. h. at 40 °C
Condensation during operation	Not permitted	Not permitted
EMC	EN 60947-5-1, EN 61000-6-2, EN 61326-3-1	EN 60947-5-1, EN 61000-6-2, EN 61326-3-1
Vibration		
In accordance with the standard	EN 60068-2-6	EN 60068-2-6
Frequency	10 - 55 Hz	10 - 55 Hz
Amplitude	0,35 mm	0,35 mm
Airgap creepage		
In accordance with the standard	EN 60947-1	EN 60947-1
Overvoltage category	III / II	III / II
Pollution degree	2	2
Rated insulation voltage	250 V	250 V
Rated impulse withstand voltage	4 kV	4 kV

Environmental data	774028	774029
Protection type		
Housing	IP40	IP40
Terminals	IP20	IP20
Mounting area (e.g. control cabinet)	IP54	IP54
Mechanical data	774028	774029
Mounting position	Any	Any
Mechanical life	10,000,000 cycles	10,000,000 cycles
Material		
Bottom	PPO UL 94 V0	PPO UL 94 V0
Front	ABS UL 94 V0	ABS UL 94 V0
Top	PPO UL 94 V0	PPO UL 94 V0
Connection type	Screw terminal	Screw terminal
Mounting type	Fixed	Fixed
Conductor cross section with screw terminals		
1 core flexible	0,2 - 4 mm², 24 - 10 AWG	0,2 - 4 mm², 24 - 10 AWG
2 core with the same cross section, flexible with crimp connectors, no plastic sleeve	0,2 - 2,5 mm², 24 - 14 AWG	0,2 - 2,5 mm², 24 - 14 AWG
2 core with the same cross section, flexible without crimp connectors or with TWIN crimp connectors	0,2 - 2,5 mm², 24 - 14 AWG	0,2 - 2,5 mm², 24 - 14 AWG
Torque setting with screw terminals	0,6 Nm	0,6 Nm
Dimensions		
Height	87 mm	87 mm
Width	45 mm	45 mm
Depth	121 mm	121 mm
Weight	255 g	255 g

Where standards are undated, the 2017-01 latest editions shall apply.

Safety characteristic data



NOTICE
 You must comply with the safety characteristic data in order to achieve the required safety level for your plant/machine.

Operating mode	EN ISO 13849-1: 2015 PL	EN ISO 13849-1: 2015 Category	EN 62061 SIL CL	EN 62061 PFH _D [1/h]	IEC 61511 SIL	IEC 61511 PFD	EN ISO 13849-1: 2015 T _M [year]
Safety contacts, delayed <30 s	PL d	Cat. 3	SIL CL 3	2,64E-09	SIL 3	1,26E-05	20
Safety contacts, delayed ≥30 s	PL c	Cat. 1	SIL CL 1	2,87E-09	SIL 2	4,64E-05	20

All the units used within a safety function must be considered when calculating the safety characteristic data.



INFORMATION
 A safety function's SIL/PL values are **not** identical to the SIL/PL values of the units that are used and may be different. We recommend that you use the PAScal software tool to calculate the safety function's SIL/PL values.



CAUTION!
 It is essential to consider the relay's service life graphs. The relay outputs' safety-related characteristic data is only valid if the values in the service life graphs are met.

The PFH value depends on the switching frequency and the load on the relay output. If the service life graphs are not accessible, the stated PFH value can be used irrespective of the switching frequency and the load, as the PFH value already considers the relay's B10d value as well as the failure rates of the other components.

Supplementary data

Service life graph

The service life graphs indicate the number of cycles from which failures due to wear must be expected. The wear is mainly caused by the electrical load; the mechanical load is negligible.

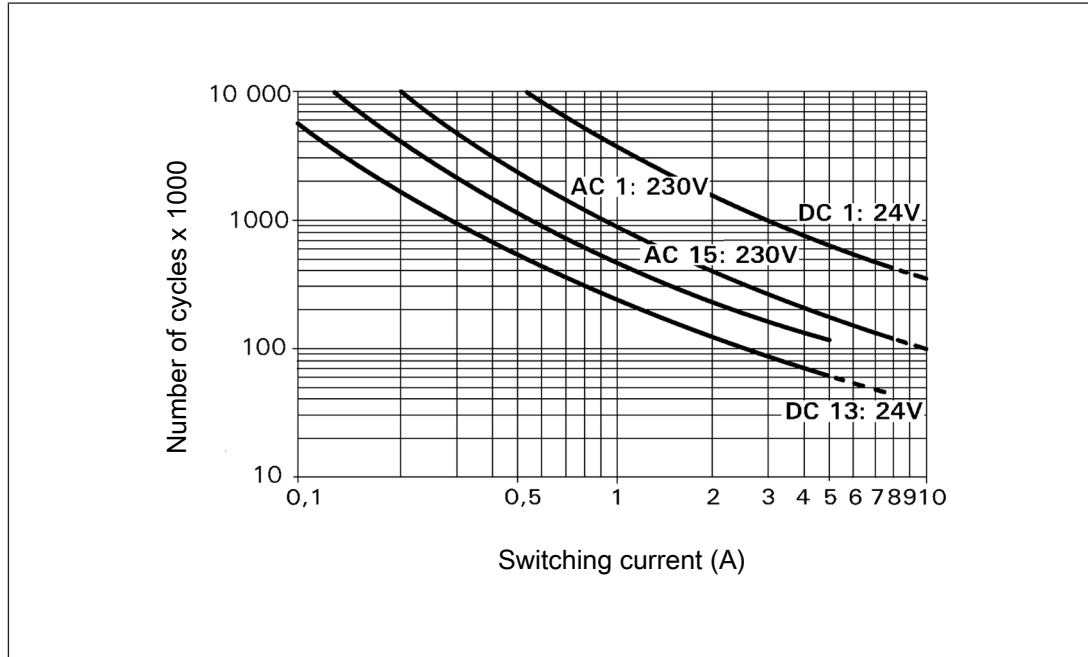

Example

- ▶ Inductive load: 0.2 A
- ▶ Utilisation category: AC15
- ▶ Contact service life: 4 000 000 cycles

Provided the application to be implemented requires fewer than 4 000 000 cycles, the PFH value (see Technical details) can be used in the calculation.

To increase the service life, sufficient spark suppression must be provided on all output contacts. With capacitive loads, any power surges that occur must be noted. With DC contactors, use flywheel diodes for spark suppression.

Order reference

Product type	Features	Connection type	Order no.
PZA	24 V AC; Delay: up to 300 s selectable	Screw terminals	774 020
PZA	24 V AC; Delay: up to 30 s selectable	Screw terminals	774 031
PZA	110 - 120 V AC; Delay: up to 300 s selectable	Screw terminals	774 023
PZA	110 - 120 V AC; Delay: up to 30 s selectable	Screw terminals	774 035
PZA	230 V AC; Delay: up to 300 s selectable	Screw terminals	774 026
PZA	230 V AC; Delay: up to 30 s selectable	Screw terminals	774 040
PZA	230 V AC; Delay: up to 3 s selectable	Screw terminals	774 038
PZA	24 V DC; Delay: up to 600 s selectable	Screw terminals	774 028
PZA	24 V DC; Delay: up to 300 s selectable	Screw terminals	774 029
PZA	24 V DC; Delay: up to 30 s selectable	Screw terminals	774 030
PZA	24 V DC; Delay: up to 3 s selectable	Screw terminals	774 041

EC declaration of conformity

This product/these products meet the requirements of the directive 2006/42/EC for machinery of the European Parliament and of the Council. The complete EC Declaration of Conformity is available on the Internet at www.pilz.com/support/downloads.

Representative: Norbert Fröhlich, Pilz GmbH & Co. KG, Felix-Wankel-Str. 2, 73760 Ostfildern, Germany

► Support

Technical support is available from Pilz round the clock.

Americas

Brazil

+55 11 97569-2804

Canada

+1 888-315-PILZ (315-7459)

Mexico

+52 55 5572 1300

USA (toll-free)

+1 877-PILZUSA (745-9872)

Asia

China

+86 21 60880878-216

Japan

+81 45 471-2281

South Korea

+82 31 450 0680

Australia

+61 3 95600621

Europe

Austria

+43 1 7986263-0

Belgium, Luxembourg

+32 9 3217575

France

+33 3 88104000

Germany

+49 711 3409-444

Ireland

+353 21 4804983

Italy, Malta

+39 0362 1826711

Scandinavia

+45 74436332

Spain

+34 938497433

Switzerland

+41 62 88979-30

The Netherlands

+31 347 320477

Turkey

+90 216 5775552

United Kingdom

+44 1536 462203

You can reach our international hotline on:

+49 711 3409-444

support@pilz.com

Pilz develops environmentally-friendly products using ecological materials and energy-saving technologies. Offices and production facilities are ecologically designed, environmentally-aware and energy-saving. So Pilz offers sustainability, plus the security of using energy-efficient products and environmentally-friendly solutions.

Energy
saving by Pilz



Pilz GmbH & Co. KG
Felix-Wankel-Straße 2
73760 Ostfildern, Germany
Tel.: +49 711 3409-0
Fax: +49 711 3409-133
info@pilz.com
www.pilz.com

PILZ
THE SPIRIT OF SAFETY

CMSE®, IndurANET p®, PAS4000®, PASscal®, PASconfig®, Pilz®, PIT®, PLID®, PMCPirotego®, PMCiendo®, PMD®, PMi®, PNOZ®, Pirmo®, PSEN®, PSENi®, PSS®, PViS®, SafetyBUS SafetyEYE®, SafetyNET p®, THE SPIRIT OF SAFETY® are registered and protected trademarks of Pilz GmbH & Co. KG in some countries. We would point out that product features mentioned in the details stated in this document, depending on the status at the time of publication and the scope of the equipment. We accept no responsibility for the validity, accuracy and entirety of the text and graphics presented in this information. Please contact our Technical Support if you have any questions.