



System Power Supply

(Cat. No. 1771-P1)

Installation Data

To the Installer

Use this publication to install a 1771-P1 system power supply.

You perform these tasks:

- prepare to install the power supply
 - install batteries into the battery pack
 - install the battery-pack housing
- install the power supply
 - mount the power supply
 - connect backplane power
 - install the battery pack
- connect ac power to the power supply

Prepare for Installation

You must use the 1771-P1 to power these programmable controllers:

- 1772 Mini-PLC-2[®] processor
- 1772 Mini-PLC-2/15[®] processor

The power supply provides a regulated 5.1V dc for the logic circuitry of the processor and I/O modules in the chassis.

If you are installing the power supply on the left side-plate of an I/O chassis, you must:

- install batteries into the battery pack
- install the battery-pack housing

Install the Batteries

The 1771-P1 comes with a separate battery pack that supplies memory backup power if the power supply shuts down due to loss of ac power on the input line or any other condition. You can use:

Battery ¹	Cat. No.	Qty.	Shipped With the 1771-P1?
D-size alkaline battery	1771-BA	2	yes
lithium battery ²	1770-XO	1	no

¹ The use of ordinary carbon-zinc D-size batteries is **not** recommended for this application.

² For applications where more backup time is desired, use the optional lithium battery. The 1771-P1 must be series B or later.

The alkaline battery provides reliable memory backup at low cost. Because the current requirement of the CMOS memory is relatively small, alkaline battery life is primarily a function of its own internal discharge, rather than usage drain. For this reason, batteries used to support memory circuitry of the Mini-PLC-2 and Mini-PLC-2/15 processor will last nearly as long as batteries in storage under similar conditions.

Examine the battery pack for a clear label that indicates proper battery polarity. If there is no such label, observe the polarity shown:

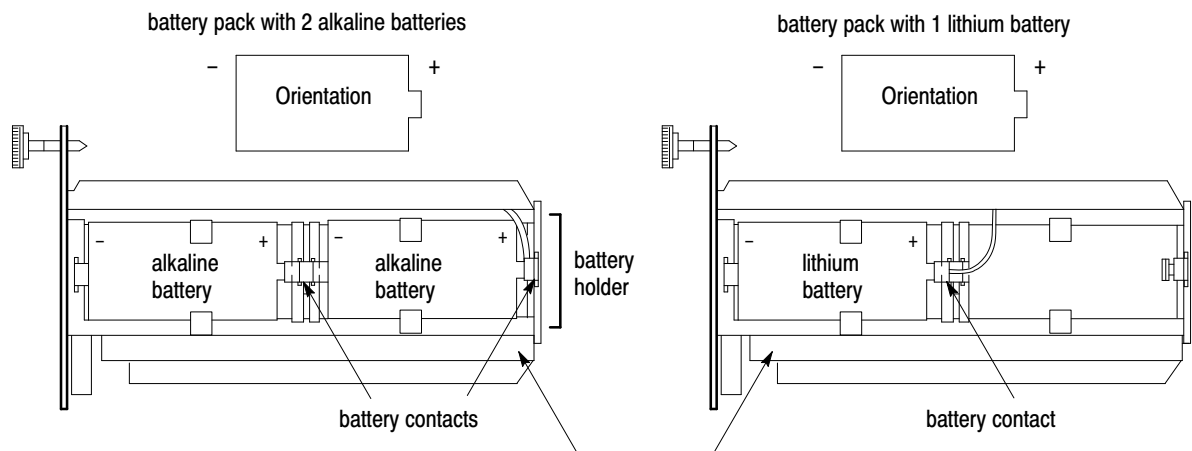

A plastic tray at the base of the battery pack helps to protect against possible alkaline cell leakage. Align each battery within the pack so that the seam of the battery case faces down, toward this protective tray.

10680/10681



We recommend that you keep a fresh supply of replacement batteries on hand. Store the replacement batteries in a cool, dry environment. In emergency situations, you may substitute these D-size alkaline batteries:

- National
- Eveready
- RayOVac[®]

To order replacement batteries for the power supply, contact your local Allen-Bradley representative.

Install the Battery-pack Housing

The battery pack, mounted on the side of the I/O chassis, provides a compact housing for the batteries. Use the hardware provided to install the mounting brackets onto the left side of the I/O chassis.

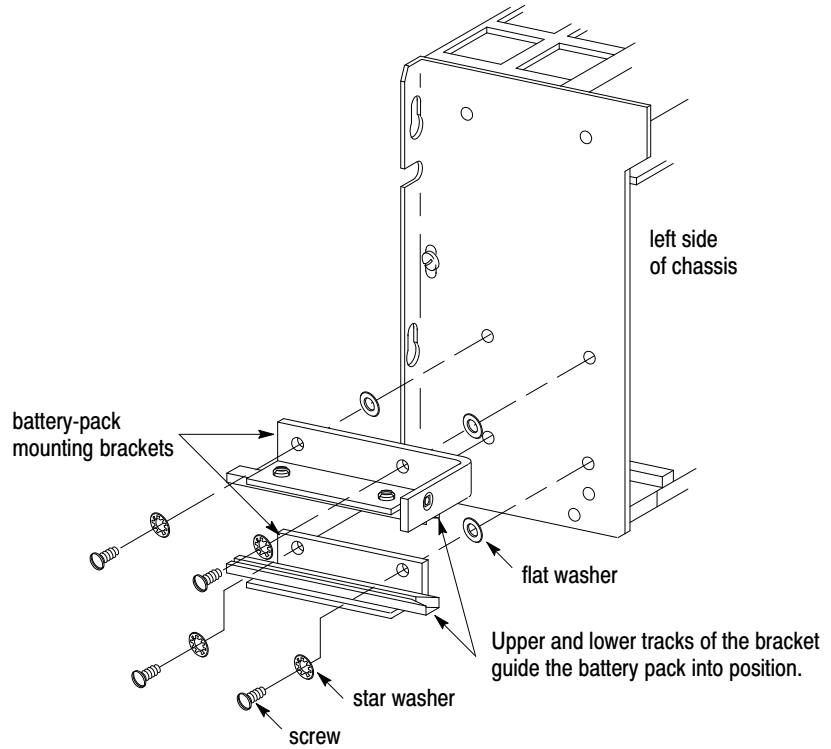

19567

Install the Power Supply and Connect Backplane Power

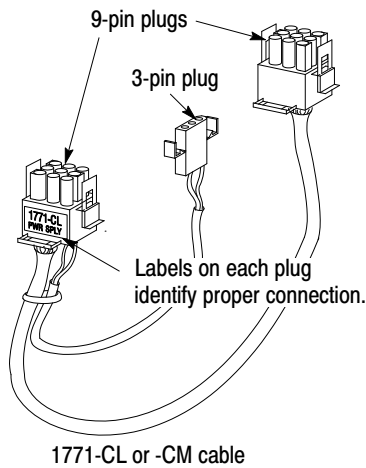

19568

If You Are Mounting the Power Supply:	Use this Power Cable (Cat. No.)
on the left side of the chassis	1771-CL
within 5 cable-feet of the I/O chassis	1771-CM

If you mount the power supply on the left side-plate of the I/O chassis, mount the I/O chassis first (if you have not already done so). See the *Universal I/O Chassis Installation Data* (publication 1771-2.210) for information on mounting the I/O chassis.

When mounted separately, the power supply can be mounted above or next to the I/O chassis. It can **not** be mounted below, since it is necessary to allow convection cooling of both the power supply and the I/O chassis. A minimum vertical distance of six inches should be maintained.

Mount the Power Supply



ATTENTION: If you do not remove system power, you could damage the module circuitry and/or cause undesired operation with possible injury to personnel.

1. Remove system power.
2. Mount the power supply.

If Mounting on Left Side of Chassis:

Use the four screws supplied with the I/O chassis to install the power supply onto the I/O chassis.

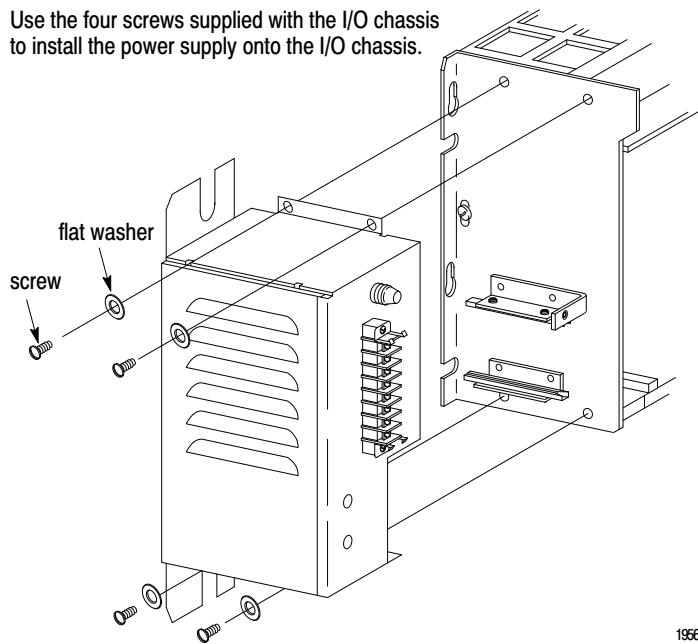

Important: Place the flat washers provided between each mounting screw and the power supply. If you do not use the flat washers, the mounting screw intrudes into the I/O chassis and interferes with module insertion

If Mounting Separately:

Mount the power supply up to 5 cable-feet from the I/O chassis.

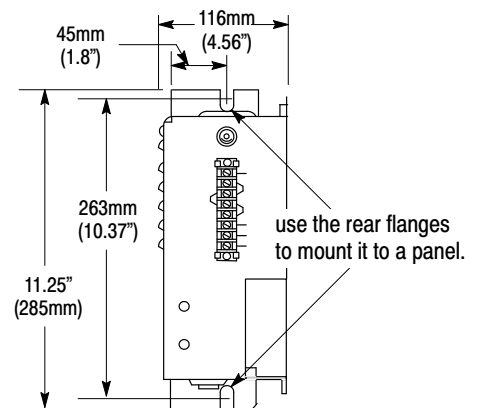

Depth is 182mm (7.16")

12593-I

Important: Do not mount the power supply below the I/O chassis.

Connect Backplane Power

1. Connect one 9-pin plug of the power cable to the 9-pin connector located on the bottom of the power supply.

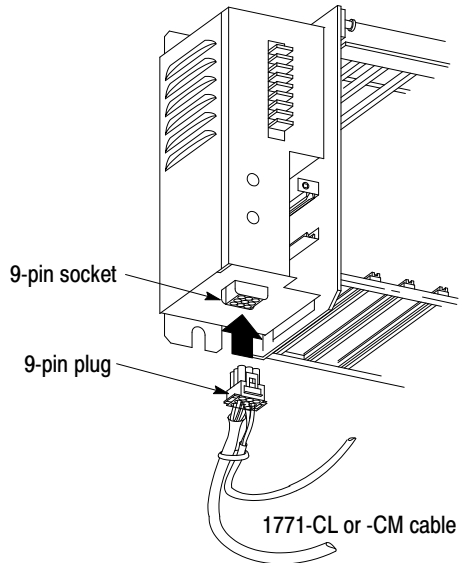

19570

2. Connect the other 9-pin plug to the external power supply connector on the I/O chassis. To make this connection, remove the mini-processor module and left-most I/O module from the I/O chassis.

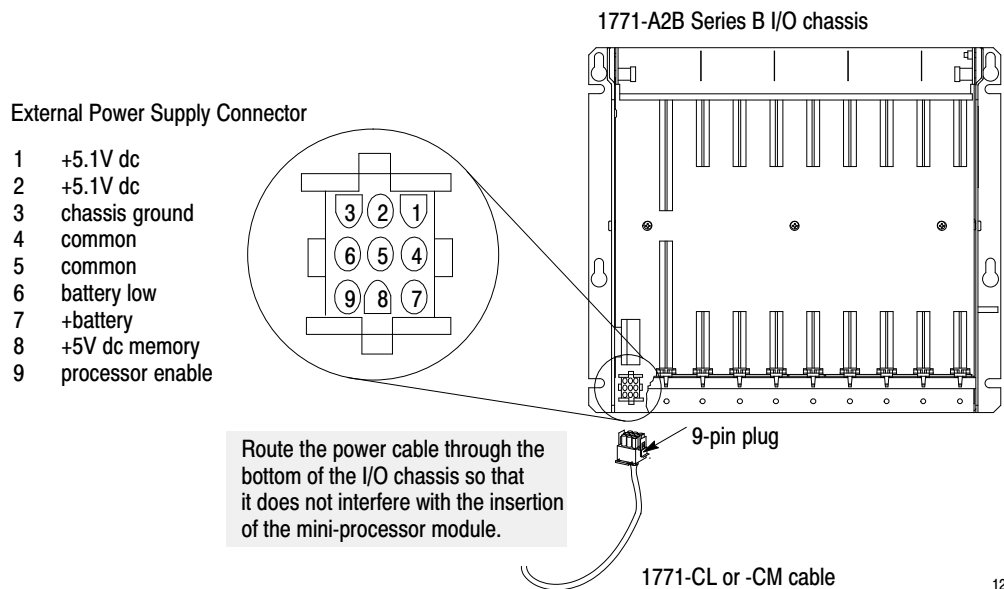

12594-1

Install the Battery Pack

1. Connect the 3-pin plug to the socket at the base of the battery pack. Align the battery pack with the card guides and slide it into the battery-pack housing.

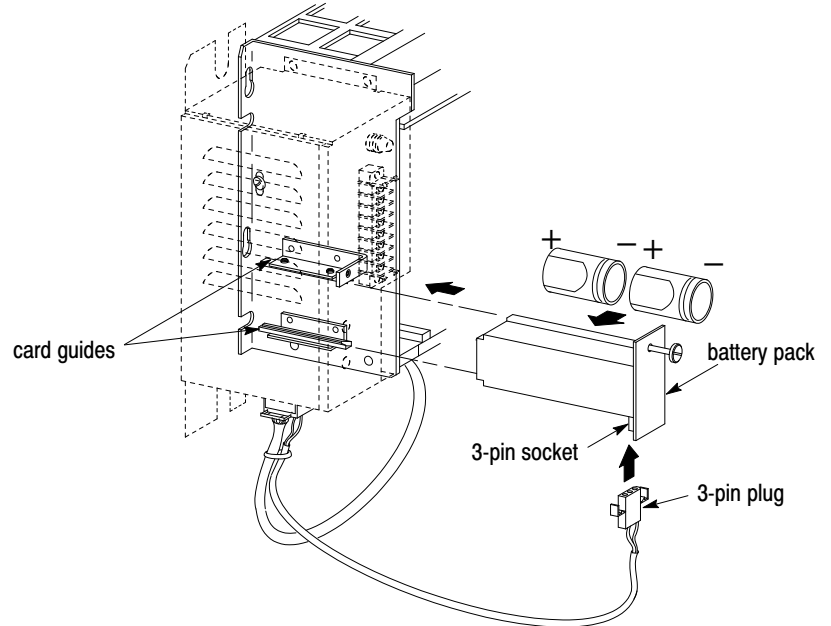

19571

2. Tighten the thumbscrew on the battery pack to secure it in the bracket.

If batteries are incorrectly installed, the BATTERY LOW indicator will flash ON and OFF as soon as power is connected to the 1771-P1. If this indicator begins to flash upon initial power-up, remove the 3-pin power cable connector from the battery pack, remove the pack, and re-install batteries with reverse polarity.

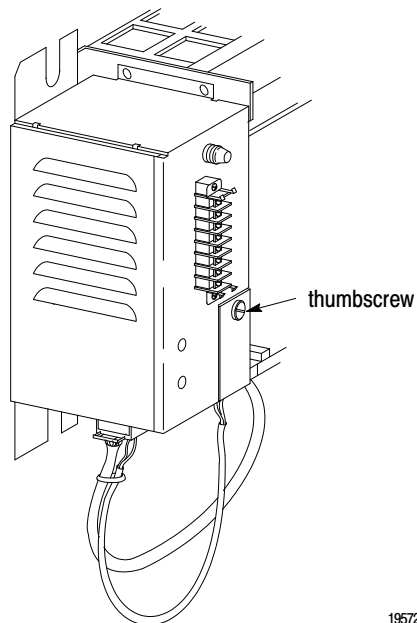

19572

Connect AC Power

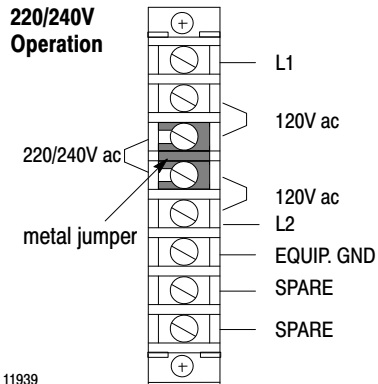
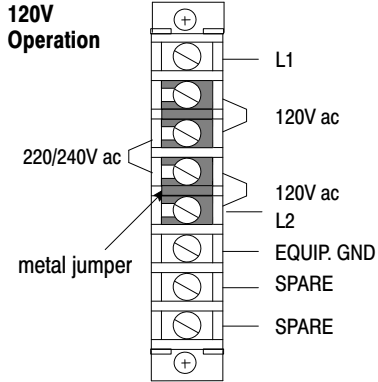

11939

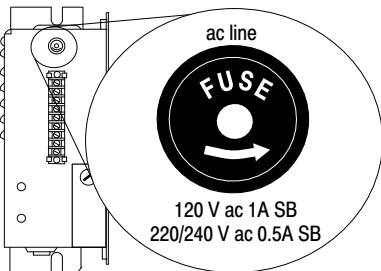

12595-1

Before connecting ac power to the power supply, you must:

- check the input voltage
- check the fuse protection

Check the Input Voltage

The power supply is factory-shipped for 120V ac operation. You can use:

- 120V ac
- or**
- 220/240V ac

Two metal jumpers are installed on the front terminal strip at the positions indicating 120V ac.



ATTENTION: Be sure the power supply is correctly jumpered for **either** 120V ac **or** 220/240V ac. Incorrect jumpering on the terminal strip may cause improper operation or damage to the power supply.

If you are using the power supply for 220/240V ac operation, remove **both** metal jumpers on the terminal strip from their original 120V positions. Install **one** of these jumpers at the terminal labeled 220/240V ac.

Check the Fuse Protection

The power supply is protected from overcurrent at its inputs by a slow-blow fuse. The power supply comes with one 1A slow-blow fuse installed for 120V operation. If you are using the power supply for 220/240V operation, remove the 1A fuse and replace it with the 0.5A slow-blow fuse that is provided. Replacement fuses are shown below:

Input Voltage	Fuse	Manufacturer's No.
120V ac	3AG 1A	Bussman: MDL 1A Littelfuse: 313001
220/240V ac	3AG 0.5A	Bussman: MDL 0.5A Littelfuse: 313.500

A replacement fuse kit (cat. no. 1771-FP) containing both 1A and 0.5A fuses is available. Contact your local Allen-Bradley representative for further information.

Connect AC Power Line

The power supply monitors input voltage for proper operating levels.

If Using the Power Supply for:	Normal Input Range ¹ :	Minimum Voltage:
120V ac operation	98 to 132V ac	92V
220/240V ac operation	196 to 250V ac	184V

¹ If input power is interrupted, the power supply signals the processor to restart automatically when the input line is restored to the normal ac input range (98V for 120V use, or 196V for 220/240V use).

AC input line connections for either 120V ac or 220/240V ac are made to the terminals marked L1 and L2. Use the grounding stud located on the bottom of the power supply to connect the power supply to the system ground bus. If you cannot do this, connect an equipment grounding conductor to EQUIP. GND.

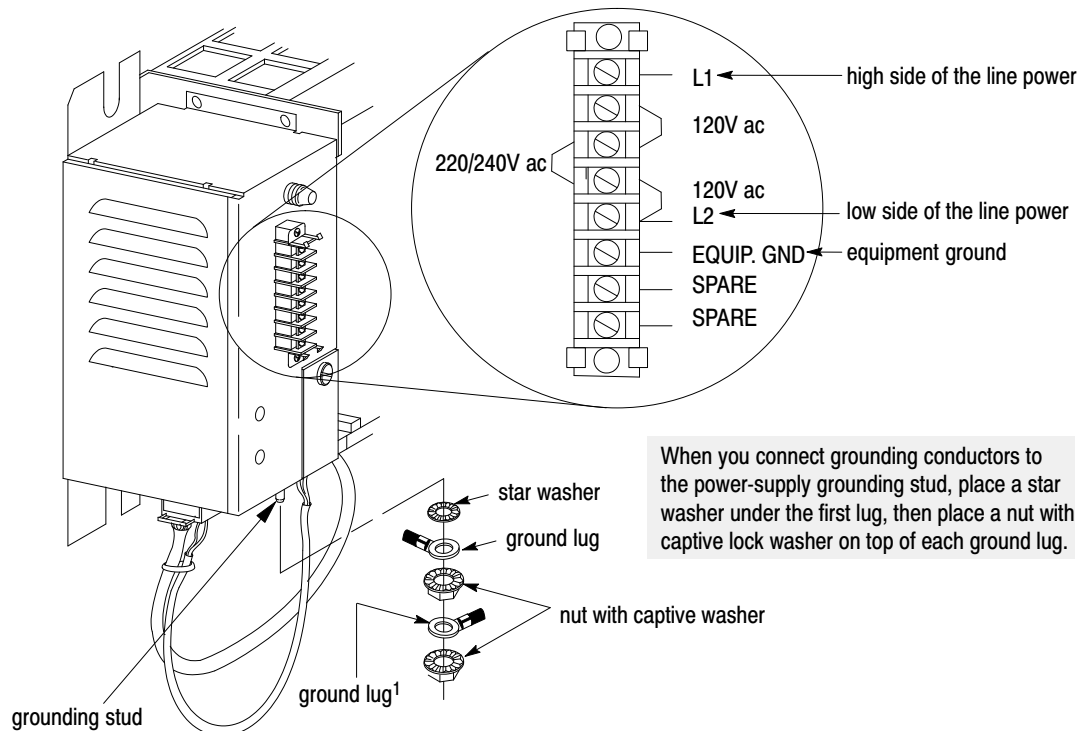

¹Use the cup washer if crimp-on lugs are not used.

In applications where the ac line is especially unstable and subject to unusual variation, a constant voltage transformer can be used to stabilize the input voltage to the power supply as well as the input voltage to user devices. If a constant voltage transformer is used, it must have filtering to remove high-harmonic content and provide a sinusoidal output. The minimum size required for any type of external transformer feeding the power supply is 160VA at full loading of the power supply.

Power Supply Outputs

The maximum output current of the power supply is 6.5 A. See I/O module product datas for specific current requirements.

Power supply outputs have built-in monitoring circuitry to protect logic circuitry in the I/O modules and the processors. During power-up and normal operation, outputs are checked for these conditions:

- overvoltage
- undervoltage
- overcurrent

The power supply shuts down if any of these conditions are detected. If this occurs, cycle ac power to the supply. To do this, disconnect and then reconnect user line power, preferably from the user-supplied main disconnect switch, mounted near the power supply.

Troubleshooting

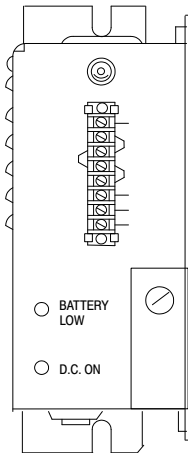

12596-1

The power supply has these LED indicators:

Indicator:	Normal Operation	If Indicator Is:	Then:
○ BATTERY LOW	off	flashing	<i>during initial power up</i> batteries are incorrectly installed — re-install batteries with reverse polarity <i>during normal operation</i> battery voltage is beginning to drop toward levels that will not support the memory ¹ — replace the batteries ²
		on	internal problem — replace the power supply
○ D.C. ON	on	off	it may be due to: <ul style="list-style-type: none"> • input voltage level not within specified range • blown fuse • overcurrent • power supply is inoperative

¹ This circuitry detects undervoltage **before** battery voltage becomes too low for memory backup. This allows you about one week to install fresh batteries.

² As long as the power supply is operating, you can replace batteries without losing the mini-processor module's memory contents.

For additional assistance, contact your local Allen-Bradley representative.

Specifications

Nominal Input Voltage/Current	120V ac @ .75A 220/240V ac @ .38A
Input Voltage Range	for 120V operation 98-132V ac for 220/240V operation 196-250V ac
Input Power	real 65W @ full load apparent 90VA @ full load
External Transformer	160VA @ full load
Frequency Range	60/50Hz
Isolation Voltage	2500V dc for 1 sec } input power to equipment/chassis ground 1800V rms for 1 sec }
Output Voltage	logic circuitry 5V dc ± 5% memory 5V dc ± 5%
Output Current	6.5A maximum @ 5V dc
Power Loss Time Delay — Input Power Loss to Processor Disable	13.5 ± 2.5msec
Battery Type	2 alkaline D-size 1.5V or 1 lithium D-size 3.4V
Replacement Fuses	for 120V operation 1A, 3AG (slow blow) Bussmann MDL 1 — Littelfuse 313001 for 220/240V operation 0.5A, 3AG (slow blow) Bussmann MDL 0.5 — Littelfuse 313.500
Weight	5.89 kg (13 lbs)
Dimensions (W x H x D)	116mm x 285mm x 182mm (4.56" x 11.25" x 7.16")
Environmental Conditions:	Operating Temperature 0 to 60°C (32 to 140°F) Storage Temperature -40 to 85°C (-40 to 185°F) Relative Humidity 5 to 95%, non-condensing
Location	side plate of bulletin 1771 I/O chassis or 5 cable-feet from I/O chassis
Cables	1771-CM 1.52m (5 ft) - connects I/O chassis to panel mounted 1771-P1 1771-CL .30m (1 ft.) - connects I/O chassis to chassis mounted 1771-P1

PLC-2 and PLC-2/15 are registered trademarks of Allen-Bradley Company, Inc.

RayOVac is a registered trademark of RayOVac Corporation.



As a subsidiary of Rockwell International, one of the world's largest technology companies — Allen-Bradley meets today's challenges of industrial automation with over 85 years of practical plant-floor experience. More than 11,000 employees throughout the world design, manufacture and apply a wide range of control and automation products and supporting services to help our customers continuously improve quality, productivity and time to market. These products and services not only control individual machines but integrate the manufacturing process, while providing access to vital plant floor data that can be used to support decision-making throughout the enterprise.

With offices in major cities worldwide

WORLD HEADQUARTERS
Allen-Bradley
1201 South Second Street
Milwaukee, WI 53204 USA
Tel: (1) 414 382-2000
Telex: 43 11 016
FAX: (1) 414 382-4444

EUROPE/MIDDLE EAST/AFRICA HEADQUARTERS
Allen-Bradley Europe B.V.
Amsterdamseweg 15
1422 AC Uithoorn
The Netherlands
Tel: (31) 2975/43500
Telex: (844) 18042
FAX: (31) 2975/60222

ASIA/PACIFIC HEADQUARTERS
Allen-Bradley (Hong Kong) Limited
Room 1006, Block B, Sea View Estate
28 Watson Road
Hong Kong
Tel: (852) 887-4788
Telex: (780) 64347
FAX: (852) 510-9436

CANADA HEADQUARTERS
Allen-Bradley Canada Limited
135 Dundas Street
Cambridge, Ontario N1R 5X1
Canada
Tel: (1) 519 623-1810
FAX: (1) 519 623-8930

LATIN AMERICA HEADQUARTERS
Allen-Bradley
1201 South Second Street
Milwaukee, WI 53204 USA
Tel: (1) 414 382-2000
Telex: 43 11 016
FAX: (1) 414 382-2400