

# Manual Motor Protectors and Magnetic Motor Protector Combinations

## Overview - System PKZ 2

UL / CSA / IEC / EN 60 947 / CE

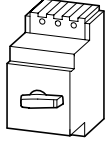
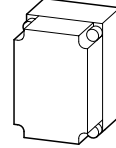
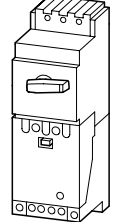
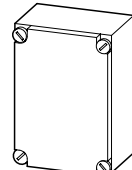

<b>Basic devices</b>		<b>Add-on functions</b>		<b>Mounting accessories</b>	
<b>Manual motor protector</b>	1	<b>Auxiliary contact modules</b>	10	<b>Mounting/wiring</b>	2
Thermal-magnetic motor protector		Signals On/Off status of PKZ 2/ZM motor protector and PKZ 2/ZM-.../S motor protector + contactor combination		Clip plate onto which combinations of the PKZ 2/ZM-... motor protector and S-PKZ 2 magnetic contactors are mounted to form motor protector combinations	
Adjustable thermal and magnetic trips		Trip indicating contacts which differentiate between overload and short-circuit tripping		Suitable for DIN rail mounting (EN 50 022). Can also be panel mounted with screws.	
Ambient compensated, phase-failure sensitive		→ page 08/030		Other mounting/wiring hardware: – adapters for direct busbar feeds in control panels – 3 phase bus connectors to eliminate the need for daisy-chain wiring of motor protector combinations	
Rated up to 42 A				→ page 08/041	
Max. 3 phase HP rating: 30 @ 460/575 V AC		<b>Current limiters</b>	8		
UL listed for group installations per NEC 430-53 CSA certified for group installations per CEC part 1, 28-206		Fuseless, current-limiting set of contacts housed in a module			
High short-circuit rating: up to 65kA/42kA @ 480/600 V AC		Increases short-circuit current rating of the PKZ 2/ZM up to 100 kA @ 500 V AC for IEC/EN applications			
CE marked		Plugs directly into the PKZ 2/ZM or can be mounted separately			
→ page 08/026		→ page 08/030			
		<b>Voltage trip modules</b>	4	<b>Door/cover mounted handle</b>	9
<b>Add-on functions</b>		Undervoltage trip modules – with early-make auxiliary contacts – with drop-off delay and early-make auxiliary contacts		Rated IP 65, NEMA/UL 12, 3R	
<b>Magnetic contactor module (SE1A...)</b>	6	Shunt trip module		3 positions: On - Off - Tripped	
AC or 24 V DC operated versions		Mounts on the side of the PKZ 2/ZM motor protector		Door interlocking feature and padlockable with up to 3 padlocks	
AC supplied with 1 N.O./1 N.C. or 2 N.O. contacts		→ page 08/032		Plug-in extension shaft to accommodate various mounting depths	
Plugs into the load side of the PKZ 2/ZM protector or can be mounted separately				Black, or red/yellow for Emergency-Stop function	
Can be equipped with 4th (neutral) pole				→ page 08/040	
Rated 20 kW @ 400/415 V AC		<b>Remote control drive</b>	5		
IEC 60 947-4-1 rated for Type 1 coordination		Electrically turns PKZ 2/ZM motor protector On and Off		<b>Corrosion-resistance enclosures</b>	3
CE marked for IEC/EN applications		Electrically resets PKZ 2/ZM motor protector from tripped position		Made of high industrial grade insulating material to house manual motor protectors and magnetic motor protector combinations	
→ consult Moeller Electric for further information		Available in both AC and DC models		UL/NEMA 12, IEC IP 40 and IP 54 environmental ratings with cover interlocked operating handle	
		Has HAND and AUTO settings for maximum flexibility		→ page 08/040	
<b>High capacity magnetic contactor module</b>	7	HAND and AUTO positions are also signalled with an auxiliary contact			
Internal current limiting feature to increase short-circuit current rating and self-protection characteristics		HAND position can be padlocked Off			
AC or 24 V DC operated versions		Type RS-PKZ 2 can be directly energized by a 24 V DC output from a PLC			
AC supplied with 1 N.O./1 N.C. or 2 N.O. contacts		→ page 08/034			
Plugs into the load side of the PKZ 2/ZM protector to create PKZ 2/ZM-.../S magnetic protector combination					
Max. 3 phase HP rating: 30 @ 460/575 V AC					
UL listed for group installations per NEC 430-53 CSA certified for group installations per CEC part 1, 28-206					
High short-circuit rating: up to 65kA/42kA @ 480/600 V AC					
IEC 60 947-4-2 rated for Type 2 coordination					
UL listed, CSA certified, in conformity with IEC/EN 60 947					
CE marked					
→ page 08/036					

## System PKZ 2 Motor Protectors Overview of Combinations

Enclosure		Modules			
Type	Type	Degree of protection	Standard auxiliary contacts	Standard auxiliary contacts	Trip-indicating auxiliary contact
			NHI11-PKZ2 NHI22-PKZ2	NHI11 S-PKZ2 NHI22 S-PKZ2 NHI2-11 S-PKZ2	AGM2-11-PKZ2
<b>Manual motor protector</b>					
PKZ2/ZM-...	–		●	–	●
	<b>Steel enclosure for surface mounting</b>				
	CS3-PKZ2	Type 1 General purpose	●	–	●
without contactor	<b>Insulated enclosure for surface mounting</b>	Type 12			
					
	CI19EE-PKZ2-NA	IP 40	●	–	●
<b>Motor protector combination</b>					
PKZ2/ZM-.../S	–		● or	●	●
	<b>Insulated enclosure for surface mounting</b>				
					
	CI43X-150-PKZ2-SP	Type 12 Dusttight industrial use	● or	● or	●
	<b>Steel enclosures for surface mounting</b>				
	GKP23-PKZ2	Type 1 General purpose	–	–	–
	GK23-PKZ2	Type 12 Dusttight industrial use	● or	● or	●

**Notes** The possible combinations of motor protectors or motor protector combinations with enclosures or modules are indicated by ●.

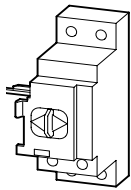
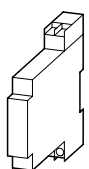
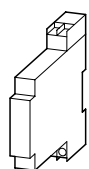
## System PKZ 2 Motor Protectors Overview of Combinations

Remote drive	Undervoltage trip	Shunt trip	Door mouting handle
			
RE-PKZ2 RS-PKZ2	U-PKZ2 UVHI-PKZ2	U-HI20-PKZ2	A-PKZ2
			H-PKZ2 RH-PKZ2
●	● or	● or	●
● or	● or	● or	●
–	● or	● or	●
●	● or	● or	●
–	● or	● or	●
●	● or	–	●
●	● or	● or	●

UL/CSA Short-circuit current rating kA RMS sym @		Max. listed branch circuit protective fuse	Max. listed branch circuit protective breaker	Adjustable thermal range set to motor FLC	Adjustable trip setting current of magnetic trips	UL/CSA max. 3-phase HP ratings			
480 V AC	600 V AC					For single phase ratings and IEC kW rating, → page 08/065			
		A	A	A	A	200 V HP	230 V HP	460 V HP	575 V HP

Manual motor protector

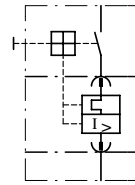
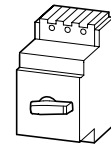

65	42	500	600	0,4 – 0,6	5 – 8	In this range, select motor protector in accordance with the motor nameplate full load current			
				0,6 – 1	8 – 14		1/2	1/2	
				1 – 1,6	14 – 22		3/4	1	
				1,6 – 2,4	20 – 35	1/2	1/2	1	1 1/2
				2,4 – 4	35 – 55	1	1	2	3
				4 – 6	50 – 80	1 1/2	1 1/2	3	5
				6 – 10	80 – 140	2	3	5	7 1/2
				10 – 16	130 – 220	3	5	10	10
				16 – 27	200 – 350	7 1/2	7 1/2	20	25
				24 – 32	275 – 425	10	10	20	30
				32 – 42	350 – 500	10	15	30	30

Magnetic motor protector combination with high capacity contactor

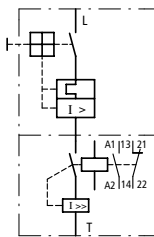
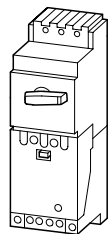

65	42	2000	2000	0,4 – 0,6	5 – 8	In this range, select motor protector in accordance with the motor nameplate full load current			
				0,6 – 1	8 – 14		1/2	1/2	
				1 – 1,6	14 – 22		3/4	1	
				1,6 – 2,4	20 – 35	1/2	1/2	1	1 1/2
				2,4 – 4	35 – 55	1	1	2	3
				4 – 6	50 – 80	1 1/2	1 1/2	3	5
				6 – 10	80 – 140	2	3	5	7 1/2
				10 – 16	130 – 220	3	5	10	10
				16 – 27	200 – 350	7 1/2	7 1/2	20	25
				24 – 32	275 – 425	10	10	20	30
				32 – 42	350 – 500	10	15	30	30

Type	List Price
Article No.	see price list
Coil voltages shown in ( )	
For other coil voltages, → page 08/047	

<b>PKZ2/ZM-0,6</b> 021859	
<b>PKZ2/ZM-1</b> 026605	
<b>PKZ2/ZM-1,6</b> 028978	
<b>PKZ2/ZM-2,4</b> 031351	
<b>PKZ2/ZM-4</b> 033724	
<b>PKZ2/ZM-6</b> 036097	
<b>PKZ2/ZM-10</b> 038470	
<b>PKZ2/ZM-16</b> 040843	
<b>PKZ2/ZM-25</b> 043216	
<b>PKZ2/ZM-32</b> 045589	
<b>PKZ2/ZM-40</b> 047962	

<b>PKZ2/ZM-0,6/S(120V60HZ)</b> 063460	
<b>PKZ2/ZM-1/S(120V60HZ)</b> 063470	
<b>PKZ2/ZM-1,6/S(120V60HZ)</b> 063480	
<b>PKZ2/ZM-2,4/S(120V60HZ)</b> 063490	
<b>PKZ2/ZM-4/S(120V60HZ)</b> 063500	
<b>PKZ2/ZM-6/S(120V60HZ)</b> 063510	
<b>PKZ2/ZM-10/S(120V60HZ)</b> 063520	
<b>PKZ2/ZM-16/S(120V60HZ)</b> 063530	
<b>PKZ2/ZM-25/S(120V60HZ)</b> 063540	
<b>PKZ2/ZM-32/S(120V60HZ)</b> 063550	
<b>PKZ2/ZM-40/S(120V60HZ)</b> 063560	

The PKZ2/ZM-... is a 3-phase thermal magnetic motor protective device incorporating adjustable bimetal trips for motor overload protection and magnetic trips to de-energize the motor circuit in case of a short-circuit.

The PKZ2/ZM-.../S is a combination of the PKZ2/ZM-... manual motor protector and the S-PKZ2 high-capacity magnetic contactor.

Both devices are UL listed and CSA certified as HP rated motor controllers which provide motor running overload protection. In addition, they are UL listed and CSA certified for group applications as per NEC 430-53(c) and CEC part 1, rule 28-206. This eliminates the need for individual motor branch circuit overcurrent protective devices for each motor, thus greatly reducing the cost and space requirements of industrial control panels and assemblies. This means that a group of motors, each protected and controlled by a PKZ2/ZM-.../S can be combined under a single branch circuit short-circuit and ground fault protective device, the maximum rating of which is marked on each PKZ2 motor protector.

In group installations involving a number of System PKZ 2 motor protectors, the maximum rating of the group branch circuit overcurrent protective device is based on the lowest backup overcurrent rating marked on each motor protector in the group, combined with applicable NEC/CEC installation rules.

Notes

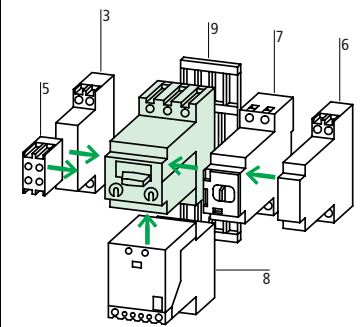

Accessories	Page
3 Standard auxiliary contact	08/030
5 Trip indicating contact	08/030
6 Shunt trip Undervoltage trip	08/032
7 Remote control operator	08/034
8 High-capacity contactor module	08/036
9 Clip plate	08/041
Other accessories	08/041

Features:

- Ratings: 42A, 600 VAC, 30HP/460V, 30HP/575V max.
- Conformity to IEC/EN 60 947 type 2 co-ordination levels
- Phase failure sensitive
- Adjustable thermal trips set to FLC. Ambient compensated.
- Adjustable magnetic trips
- Open or door mounted handle, padlockable, with 3 position indication (On - Off - Trip), see accessories
- Finger-safe construction
- 35 mm DIN rail or panel mounting

# System PKZ 2 Motor Protectors

## Motor Protectors without Trip Module

UL / CSA / IEC / CE

Manual Motor Protectors,  
Motor Protector Combinations

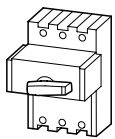
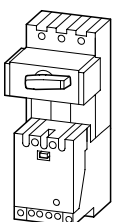
	Rated un-interrupted current	Type Article No.	List Price see price list
	A	Coil voltages shown in ( )  For other coil voltages, → page 08/048	
<b>Basic device</b>			
	42	<b>PKZ2</b> 026606	
 PKZ 2 basic unit with S-PKZ 2 high capacity contact module mounted (1 N.O., 1 N.C.) Supplied on C-PKZ2 clip plate	42	<b>PKZ2/S (120V60HZ)</b> 063570	

**Notes**

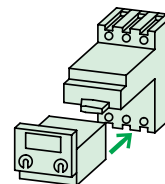

Accessories → page 08/041

**Circuit for ZM... PKZ2**

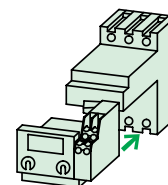
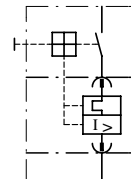

**ZMR...PKZ2**

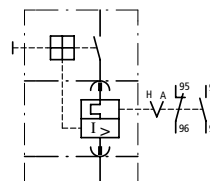

The PKZ 2 manual motor protector and PKZ 2/S... motor protector combination without plug-in trip modules make up one frame size rated for a maximum continuous motor load current of 42A. These devices can be stocked, or mounted and wired in a panel, without prior knowledge of motor Hp ratings. Motor overload and overcurrent protection is provided by the plug-in motor protective trip modules shown at the next page which are inserted into the slots below the handle (between the disconnect and contactor portions) and enable the motor protector to cover a motor range from fractional Hp up to 30 Hp at 460/575V AC.

Once motor loads are determined, selection of the appropriate plug-in motor protective trip module can take place. Exchanging trip modules is easy and does not require any removal of wiring or cables. Removal of the trip modules provides an additional safety benefit by creating an open circuit path to the motor. This still allows the performance of routine motor maintenance tasks and circuit function checks but effectively rules out any inadvertent energization of the motor.

# System PKZ 2 Motor Protectors

## Motor Protective Trip Modules

UL / CSA / IEC / CE

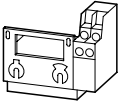
UL/CSA max. 3 phase HP rating at				Adjustable thermal range (set to motor FLC)	Setting range of adjustable magnetic trips	Type	List Price		
For single phase ratings, see page 08/065 200 V 230 V 460 V 575 V									
HP	HP	HP	HP	A	A	Article No.	see price list		
<b>Plug-in motor protective trip modules</b>									
with overload trip  	In this range, select motor protector in accordance with the motor name-plate FLC	1/2	1/2	0,4 – 0,6	5 – 8	ZM-0,6-PKZ2 024232	Standard trip modules ZM-...-PKZ2 are inserted on the load side of the motor protector disconnect handle. In case of overload or short circuit, the trip module will cause the motor protector switch mechanism to open and disconnect power to the load.  <b>Features:</b> <ul style="list-style-type: none"> <li>Adjustable thermal and magnetic trips set in accordance with the motor FLC.</li> <li>Tamper-proof lids that cover thermal and magnetic settings when the device is on.</li> <li>Ambient compensation.</li> <li>Phase failure sensitivity.</li> <li>Coding accessory to insure insertion of correct module for the motor rating</li> </ul>		
		1/2	1	0,6 – 1	8 – 14	ZM-1-PKZ2 028979			
		3/4	1	1 – 1,6	14 – 22	ZM-1,6-PKZ2 031352			
		1/2	1/2	1	1 1/2	1,6 – 2,4		20 – 35	ZM-2,4-PKZ2 033725
		1	1	2	3	2,4 – 4		35 – 55	ZM-4-PKZ2 036098
		1 1/2	1 1/2	3	5	4 – 6		50 – 80	ZM-6-PKZ2 038471
		2	3	5	7 1/2	6 – 10		80 – 140	ZM-10-PKZ2 040844
		3	5	10	10	10 – 16		130 – 220	ZM-16-PKZ2 043217
		7 1/2	7 1/2	20	25	16 – 27		200 – 350	ZM-25-PKZ2 045590
		10	10	20	30	24 – 32		275 – 425	ZM-32-PKZ2 047963
		10	15	30	30	32 – 42		350 – 500	ZM-40-PKZ2 050336
		with overload relay function, with Hand/ Auto position  	In this range, select motor protector in accordance with the motor name-plate FLC	1/2	1/2	0,4 – 0,6		5 – 8	ZMR-0,6-PKZ2 033943
1/2	1			0,6 – 1	8 – 14	ZMR-1-PKZ2 033950			
3/4	1			1 – 1,6	14 – 22	ZMR-1,6-PKZ2 033952			
1/2	1/2			1	1 1/2	1,6 – 2,4	20 – 35	ZMR-2,4-PKZ2 033955	
1	1			2	3	2,4 – 4	35 – 55	ZMR-4-PKZ2 033957	
1 1/2	1 1/2			3	5	4 – 6	50 – 80	ZMR-6-PKZ2 033966	
2	3			5	7 1/2	6 – 10	80 – 140	ZMR-10-PKZ2 033967	
3	5			10	10	10 – 16	130 – 220	ZMR-16-PKZ2 033968	
7 1/2	7 1/2			20	25	16 – 27	200 – 350	ZMR-25-PKZ2 033969	
10	10			20	30	24 – 32	275 – 425	ZMR-32-PKZ2 033973	
10	15			30	30	32 – 42	350 – 500	ZMR-40-PKZ2 033975	

## System PKZ 2 Motor Protectors

### Auxiliary Contacts, Trip-indicating Contacts, Trip Indicator, Current Limiter

Number of Auxiliary Contacts N.O. = normally open N.C. = normally closed N.O. N.C.	Connection Diagram	Circuit Diagram	Type
<b>Standard auxiliary contacts</b> for motor protectors and motor protector combinations			
1 1			<b>+NHI11-PKZ2</b> 093050
2 2			<b>+NHI22-PKZ2</b> 095423
for motor protector combinations			
1 1			<b>+NHI115-PKZ2</b> 005250
2 2			<b>+NHI225-PKZ2</b> 002877
2 x 1 2 x 1			<b>+NHI2-115-PKZ2</b> 012369
<b>Trip-indicating auxiliary contacts</b> with short-circuit indicator 2 x (1 N.O. 1 N.C.)			
			<b>+AGM2-11-PKZ2</b> 019488
<b>Short-circuit indicator</b>			
			<b>+K-AGM-PKZ2</b> 024234
<b>Current limiter</b> Fuseless, current limiting set of contacts housed in a module. Increases short-circuit current rating of PKZ 2/ZM up to 100kA/500V AC in IEC group applications. Not UL/CSA.			
			<b>+CL-PKZ2</b> 078812

## System PKZ 2 Motor Protectors

### Auxiliary Contacts, Trip-indicating Contacts, Trip Indicator, Current Limiter

Type	List Price
Article No. when ordered separately	see price list
	<b>NHI11-PKZ2</b> 090677
	<b>NHI22-PKZ2</b> 097796
	<b>NHI115-PKZ2</b> 007623
	<b>NHI225-PKZ2</b> 000504
	<b>NHI2-115-PKZ2</b> 009996
	<b>AGM2-11-PKZ2</b> 017115
	<b>K-AGM-PKZ2</b> 021861
	<b>CL-PKZ2</b> 076439

The side mounted auxiliary contacts NHI...-PKZ2 operate in conjunction with the motor protector contacts. Can be mounted to a motor protector or motor protector combination. Can be combined with AGM trip indicating contacts.

Type NHI2-115-PKZ2 has a set of contacts operated by the motor protector, the other set by the contactor. Can be mounted to motor protector combination. Can be combined with AGM trip-indicating contacts.

AGM...-PKZ2 provides trip differentiating contacts and is supplied with K-AGM-PKZ2 red short-circuit indicator. Can be mounted to motor protector or motor protector combination. Can be combined with NHI... or NHI...S

Provides a visual signal of a short-circuit trip condition via a resettable red flag indicator. Differentiated trip signalling possible in conjunction with handle position.

Max. rated operational voltage  $U_e = 690$  V  
Can be mounted to motor protector or mounted separately on EZ base.

#### Notes

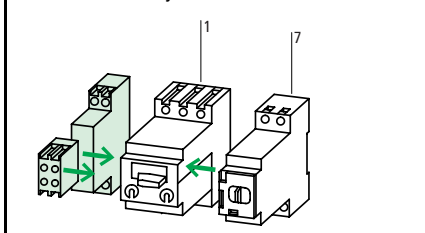

Accessories	page
1 Motor protector	08/026
7 Remote drives	08/034
Other accessories	08/041

#### Trip-indicating auxiliary contact and short-circuit indicator

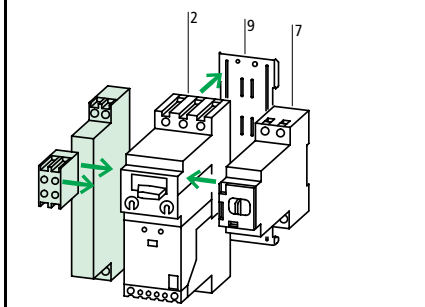

Accessories	page
2 Motor protector	08/026
7 Remote drive	08/034
9 Clip plate	08/041
Other accessories	08/041

#### Current limiter

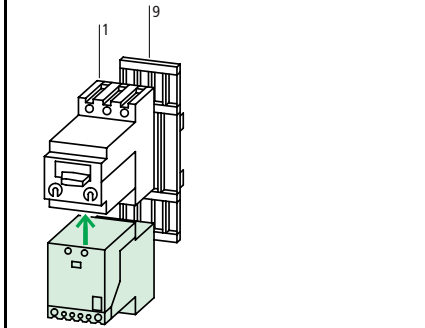

Accessories	page
1 Motor protector	08/026
9 Clip plate	08/041
Other accessories	08/041

## System PKZ 2 Motor Protectors Shunt Trips, Undervoltage Trips

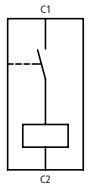
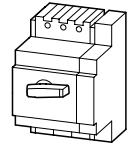
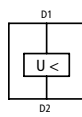
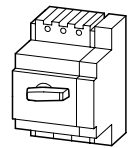
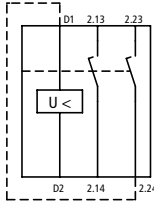
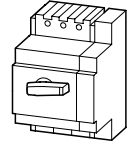
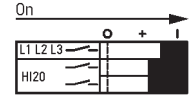
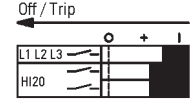
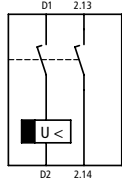
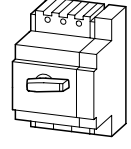
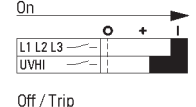
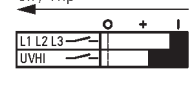
Circuit diagram	Connection diagram	Operating voltage	Type
		Voltage and frequency combinations possible with one coil in the voltage trip	Article No. When ordered with basic device  Coil voltages shown in ( )  For other coil voltages, → page 08/049
<b>Shunt trips</b>			
For AC and DC 		24 V DC    48 V DC    60 V DC 24 V 50 Hz    48 V 50 Hz 24 V 60 Hz    48 V 60 Hz	<b>+A-PKZ2-A</b> 063966
		110 V DC    125 V DC    250 V DC 110 V 50 Hz    127 V 50 Hz    220 V 50 Hz 230 V 50 Hz    240 V 50 Hz 110 V 60 Hz    120 V 60 Hz    208 V 60 Hz 220 V 60 Hz    240 V 60 Hz	<b>+A-PKZ2-B</b> 063965
		380 V 50 Hz    400 V 50 Hz    415 V 50 Hz 440 V 50 Hz    500 V 50 Hz 480 V 60 Hz    600 V 60 Hz	<b>+A-PKZ2-C</b> 063962
<b>Undervoltage trips, undelayed</b>			
		for AC	<b>+U-PKZ2(120V60HZ)</b> 063612
		for DC	<b>+U-PKZ2(24V DC)</b> 002558
For AC, with auxiliary contact 		On 	<b>+U-HI20-PKZ2(120V60HZ)</b> 063626
		Off / Trip 	
<b>Drop-off Delayed (200 ms)</b>			
For AC, with auxiliary contact 		On 	<b>+UVHI-PKZ2(120V60HZ)</b> 063637
		Off / Trip 	

## System PKZ 2 Motor Protectors Shunt Trips, Undervoltage Trips

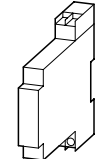
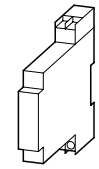
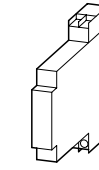
	Type	List Price	
	Article No. when ordered separately  Coil voltages shown in ( ) For other coil voltages, → page 08/049	see price list	
	<b>A-PKZ2-A</b> 063967		Shunt trips are available in three models which cover a wide range of AC and DC voltages. They can be used in combination with R(E)(S)-PKZ2 remote control drives.
	<b>A-PKZ2-B</b> 063964		
	<b>A-PKZ2-C</b> 063930		
	<b>U-PKZ2(120V60HZ)</b> 065686  <b>U-PKZ2(24V DC)</b> 014463		Can be combined with the motor protector to accomplish Emergency-Stop circuitry per IEC/EN 60 204. Can be used in combination with R(E)(S)-PKZ2 remote control drives.
	<b>U-HI20-PKZ2(120V60HZ)</b> 063655		
	<b>UVHI-PKZ2(120V60HZ)</b> 063664		Has a built-in time delay to prevent tripping due to momentary power losses of 200 ms or less. In the trip position, both contacts will be closed.  Can be used in combination with R(E)(S)-PKZ2 remote control drives.

Notes

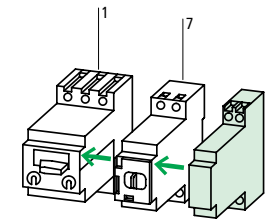

Accessories	page
1 Motor protector	08/026
7 Remote control drive	08/034
Other accessories	08/041

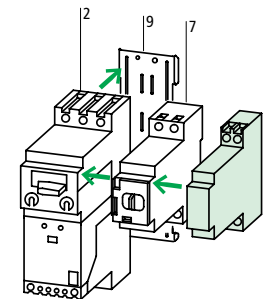

Accessories	page
2 Motor protector	08/026
7 Remote control drive	08/034
9 Clip plate	08/041
Other accessories	08/041
Other actuating voltages	08/049

## System PKZ 2 Motor Protectors Remote Control Drives

Circuit diagram for pulsed operation

### Remote control drive RE-PKZ2

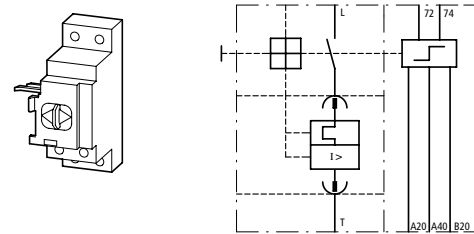

#### OFF and RESET separate

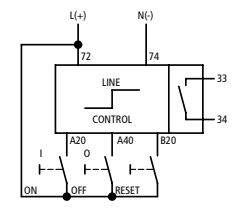

#### OFF equals RESET

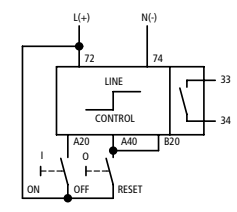

Line and control feeds have the same potential.

The control section can be energized by a single impulse ( $\leq 2$  VA/W power draw) of 15 ms duration, or by a maintained contact. Upon energizing, the line connection draws its power requirement (700 VA/W for a duration of 30 ms) directly from the line.

Control section can also be actuated via auxiliary contacts from various Moeller Electric components: NHI, AGM, ETR4-VS3, EK... and dry output contacts from PLCs with no RC filter type surge suppression.

### Remote control drive RS-PKZ2

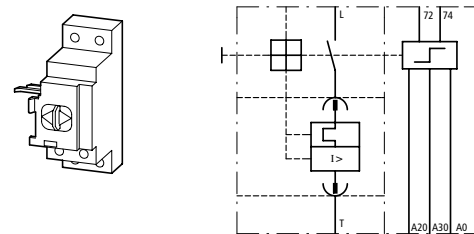

#### OFF equals RESET

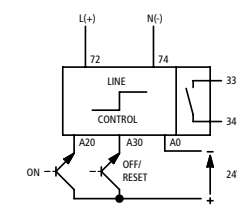
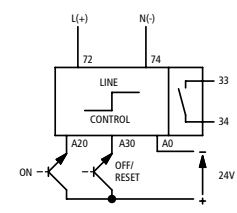

Line and control sections are galvanically separated. The control section is energized solely from a 24V DC source by a single impulse ( $\leq 2$  VA/W, 15 ms duration) or by a maintained contact. Suitable for energizing directly from an electronic PLC output.

Upon energizing, the line connection draws its power requirement (700 VA/W for a duration of 30 ms) directly from the line.

### Notes

#### Minimum command time for RE-PKZ2, RS-PKZ2 remote control drives

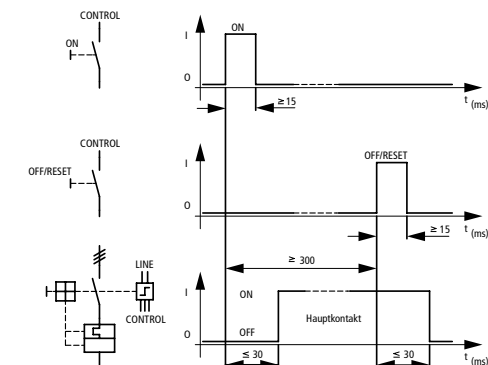

## System PKZ 2 Motor Protectors Remote Control Drives

Type	List Price
Article No.	see price list
Control voltage is shown in ( ) For other voltages, → page 08/050	

RE-PKZ2(110–120V50/60HZ,DC)  
063673

Remote control drives can be used with both the motor protector and motor protector combination. They are used to electrically operate the motor protector (ON / OFF and Reset to OFF (after trip) operations.) They can be switched off at the device and the thumb-grip handle can be padlocked using a 6 mm padlock. Suitable for use with either AC or DC voltages.

RE-PKZ2(24V50/60HZ,DC)  
063670

Can be combined with undervoltage trips and shunt trips. Always use standard auxiliary contact Type NHI... when using remote control drives to electrically signal the open or closed status of the motor protector.

Remote control drives cannot be used in conjunction with (R)H-PKZ2 door interlock handle.

RS-PKZ2(110–120V50/60HZ,DC)  
063685

Mounting is possible in both ON and OFF positions of the motor protector. An internal electronic interlock always sets OFF as the default setting.

The thumb-grip handle has 2 positions: HAND and AUTO

In HAND  
• the drive displays the color GREEN and blocks any remote electrical actuation. the internal signalling contact 33/34 is open.

RS-PKZ2(24V50/60HZ,DC)  
063682

In AUTO  
• the drive displays the color RED, indicating that remote electrical actuation is possible. The internal signalling contact 33/34 is closed.

### Notes

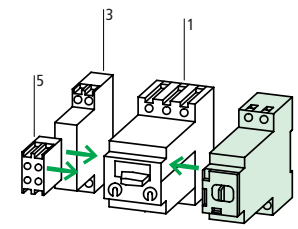

Accessories	page
1 Motor protector	08/026
3 Standard auxiliary contact	08/030
5 Trip-indicating auxiliary contact	08/030
Other accessories	08/041

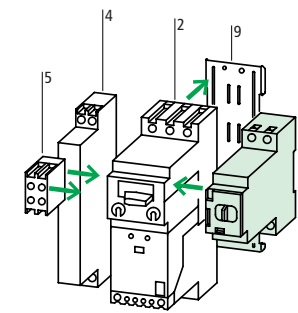

Accessories	page
2 Motor protector	08/026
4 Standard auxiliary contact	08/030
5 Trip-indicating auxiliary contact	08/030
9 Clip plate	08/041
Other actuating or supply voltages	08/050

Note:  
The supply voltage refers to the line and control feed for the RE-PKZ 2 and the line feed for the RS-PKZ 2. The control section of the RS-PKZ 2 is supplied with 24 V DC only. Both remote control drives will draw their power requirement (700 VA for 30 ms) directly from the line.

RE-PKZ2 and RS-PKZ2 remote control drives can be used to electrically operate the motor protector from a remote location:

- OFF to ON
- ON to OFF
- Reset to OFF after trip

Highly desirable in factory automated operations and/or physically hard to reach locations!

## System PKZ 2 Motor Protectors Magnetic Contactors, Surge Suppressors

Circuit diagram	UL/CSA Maximum 3 phase HP rating at				Number of contacts		For use with
	200 V HP	230 V HP	460 V HP	575 V HP	N.O. N.O.	N.C. N.C.	

### High capacity magnetic contactor module

With internal current limitation feature to increase short-circuit current rating and self-protection characteristics of PKZ 2/ZM-.../S motor protector combination

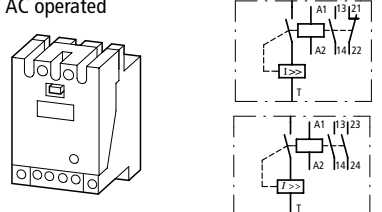
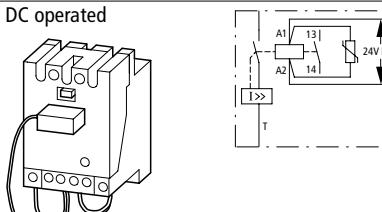
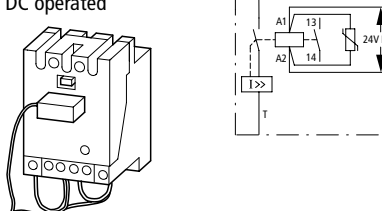
AC operated	10	15	30	30	1	1	PKZ2 PKZ2/ZM-...
							
					2	-	PKZ2 PKZ2/ZM-...
DC operated	10	15	30	30	1	-	PKZ2 PKZ2/ZM-...
							

### Surge suppressor Varistor type for AC coils

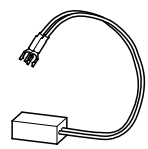
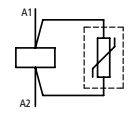
	24 – 48 V	S-...-PKZ2
	110 – 250 V	
	380 – 415 V	

### Mounting base

For separate mounting of the S-...-PKZ2 contactor

	S-...-PKZ2 CL-PKZ2
--	-----------------------

## System PKZ 2 Motor Protectors Magnetic Contactors, Surge Suppressors

Type	List Price
Article No. Coil voltages shown in ( ) For other voltages, → page 08/051	see price list
<b>S-PKZ2(120V60HZ)</b> 063694	
<b>S/HI20-S-PKZ2(120V60HZ)</b> 063701	
<b>S-G-PKZ2(24VDC)</b> 070921	
<b>VGSPKZ48</b> 063974	Surge suppressors for AC coils of S-...-PKZ2 contactors.
<b>VGSPKZ250</b> 063973	RC filters also available upon request.
<b>VGSPKZ415</b> 063972	
<b>EZ-PKZ2</b> 028596	Used to mount the S-...-PKZ2 contactor separate from the PKZ2... motor protector. Always required for reversing applications. Also, allows extra contactor operated auxiliary contacts to be added: HI11-S/EZ-PKZ2 (1 N.O. and 1 N.C.). The base can either be panel mounted using screws (M4) or clipped onto a 35mm DIN rail conforming to EN 50 022.

### Notes

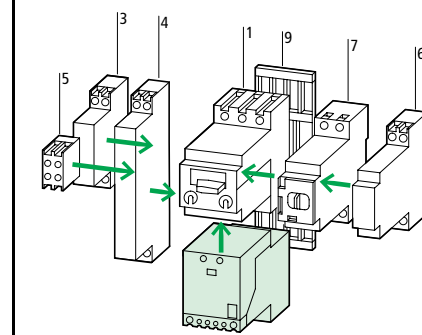



### Accessories





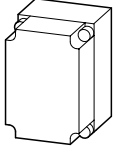
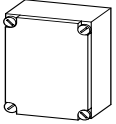

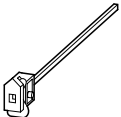
	page
1 Motor protector	08/026
3 Standard auxiliary contact	08/030
4 Standard auxiliary contact	08/030
5 Trip-indicating auxiliary contact	08/030
6 Shunt trip Undervoltage trip	08/032
7 Remote control drive	08/034
9 Clip plate	08/041
Other accessories	08/041
Other actuating voltages	08/051

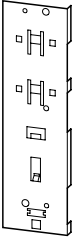
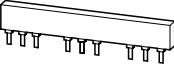

## System PKZ 2 Motor Protectors Enclosures, Accessories



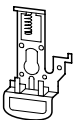

		For use with	Type	List Price
			Article No.	see price list
<b>Enclosures for Motor Protectors</b>				
	Insulating material Dust-tight NEMA Type 12	PKZ2/ZM-... +NHI + AGM + U or A + (R)H	<b>CI19EE-PKZ2-NA</b> 003183	NEMA Type 12 dust-tight industrial use enclosure with lift-off cover. Must be equipped with (R)H-PKZ2 door mounted handle. Comes with a 15 mm DIN rail, and provided with top and bottom steel plates and brass strip for continuity of ground.
	Steel General purpose NEMA Type 1	PKZ2/ZM-... +NHI + AGM + U or A or RE or RS	<b>CS3-PKZ2</b> 105073	General purpose enclosure with lift-off cover. Includes a rectangular cutout for the motor protector handle (not necessary to include the (R)H-PKZ2 door mounted handle). Also includes a knockout for the R(E)(S)-PKZ2 remote control drives and a knock-out for a pilot light.
<b>Enclosures for Motor Protector Combinations</b>				
	Insulating material Dust-tight NEMA Type 12 IEC Type IP 65	PKZ2/ZM-.../S + NHI(S) + AGM + U or A + (R)H-PKZ2	<b>CI43X-150-PKZ2-NA</b> 005352	Corrosion-resistant and dust-tight insulating material enclosure. Must be equipped with the (R)H-PKZ2 door mounted handle.
	Steel General purpose NEMA Type 1	PKZ2/ZM-.../S + NHI(S) + AGM + U or A + (R)H-PKZ2	<b>GKP23-PKZ2</b> 105370	General purpose enclosure with hinged cover. Must be equipped with the (R)H-PKZ2 door mounted handle.
	Steel Dust-tight NEMA Type 12		<b>GK23-PKZ2</b> 105253	
<b>Door/cover mounted handle NEMA/UL Type 3R, 12 and IEC IP 65</b>				
	Color: black for use as a main disconnect switch		<b>H-PKZ2</b> 043218	Door/cover interlock feature. Lockable in ON or OFF position. Up to three padlocks, hasp thickness 4 - 8 mm.
	For use in MCCs with PKZ2 turned 90°. Color: black for use as a main disconnect switch		<b>H-PKZ2-MCC</b> 201427	
	Color: red/yellow for use a main disconnect switch with Emergency-Stop function		<b>RH-PKZ2</b> 045591	Door cover interlocking feature. Lockable in the ON position only. Up to three padlocks, hasp thickness 4 - 8 mm.
	For use in MCCs with PKZ2 turned 90°. Color: red/yellow for use a main disconnect switch with Emergency-Stop function		<b>RH-PKZ2-MCC</b> 201428	
<b>Plug-in extension shaft for for/cover mounted handle</b>				
	can be extended as required for mounting depths from 171 to 300 mm		<b>A-H-PKZ2</b> 047964	

## System PKZ2 Motor Protectors Accessories

	Type	List Price
	Article No.	see price list
<p><b>Clip plate</b></p>  <p>Plate onto which the PKZ2/ZM-... motor protector and S-PKZ2 high capacity magnetic contactor are mounted as a unit.</p>	<b>C-PKZ2</b> 052710	<p>Snaps onto one 15 mm high or two 10 mm high DIN rail(s) conforming to EN 50 022-35. Can alternatively be panel mounted using M4 screws.</p> <p>Can also be mounted on AD busbar adapters (→ page 08/042)</p>
<p><b>Three-phase feeder bus connector</b></p> <p>Reduces mounting space and wiring time by eliminating daisy-chain wiring. Can be joined to accommodate more units. Finger-safe construction.</p>		
 <p>For wiring three PKZ2 motor protectors. Space is provided for either two auxiliary contacts or two voltage trips.</p>	<b>B3.1/3-PKZ2</b> 033940	222 mm wide. Can be joined to feed additional PKZ2/ZM. Max. rating: 100 A
 <p>For wiring two PKZ2 motor protectors. Space is provided for either one auxiliary contact or one voltage trip.</p>	<b>B3.1/2-PKZ2</b> 063969	140 mm wide. Can be joined to feed additional PKZ2/ZM. Max. rating: 85 A
<p><b>Incoming supply terminal</b></p>  <p>Terminal used to feed bus connectors. Accepts AWG 14 - 0, Cu only.</p>	<b>BK50/3-PKZ2</b> 033941	For connecting larger cable cross sections to feed bus connectors. Finger-safe design is maintained and protects against shock hazards.
<p><b>Cover for unused terminals</b></p>  <p>Protection against accidental contact of unused terminals on the bus connector.</p>	<b>H-B3-PKZ2</b> 063968	The feeder bus connector must have a latching provision to secure the cover.
<p><b>Padlocking feature</b></p>  <p>For padlocking the motor protector in the OFF position when the panel door is open.</p>	<b>SVB-PKZ2</b> 050337	Accepts up to three padlocks; hasp thickness 5 - 8 mm. Suitable for 1/4" padlocks.
<p><b>Coding pins</b></p>  <p>Uses binary coding to match the motor protector with a trip module.</p>	<b>CS-PKZ2</b> 055083	Coding pins prevent switching of the motor protector if an incorrect trip module is inserted.

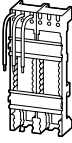
## System PKZ 2 Motor Protectors

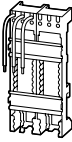
### Control Panel Busbar Adapters

	For use with	Rated operational current	Adapter supply leads	Adapter width	Type	List Price
		$I_e$ A	AWG	mm	Article No.	see price list
<b>Control panel busbar adapter, 3 pole</b>						
For mounting in industrial control panels on Cu 20 x 5 mm busbar arrangements with 60 mm phase separation.						
	PKZ2/ZM-... PKZ2/ZM-.../S without accessories	40	8	72	<b>AD40/5-1</b> 025401	The back of the adapter connects onto the bus. Components are mounted on top of the adapter and wired to the supply leads.  All assembly is done under de-energized (power OFF) conditions.
	PKZ2/ZM-... PKZ2/ZM-.../S with all possible accessories	40	8	144	<b>AD40/5-2</b> 025403	
For mounting in industrial control panels on Cu 30 x 10 and 20 x 10 mm busbar arrangements with 60 mm phase separation.						
	PKZ2/ZM-... PKZ2/ZM-.../S without accessories	40	8	72	<b>AD40/10-1</b> 025402	
	PKZ2/ZM-... PKZ2/ZM-.../S with all possible accessories	40	8	144	<b>AD40/10-2</b> 025404	
	<b>Adapter extension</b>	-	-	9	<b>AD-E</b> 060511	Push-fit strip, can be mounted onto AD... to extend mounting width

## System PKZ 2

### Standard Coil Voltages

High capacity motor protector combinations  
Contact module with 1 N.O. and 1 N.C. contact

AC	PKZ2/ZM-10/ S(...)	PKZ2/ZM-16/ S(...)	PKZ2/ZM-25/ S(...)	PKZ2/ZM-32/ S(...)	PKZ2/ZM-40/ S(...)	PKZ2/S(...)
	Article No. <sup>1)</sup>	Article No. <sup>1)</sup>	Article No. <sup>1)</sup>	Article No. <sup>1)</sup>	Article No. <sup>1)</sup>	Article No. <sup>1)</sup>
<b>Standard voltages</b>	See price list	See price list	See price list	See price list	See price list	See price list
24V 50Hz	095146	076165	073793	076167	002607	063580
48V 50Hz	059124	059131	059145	059152	059166	063581
240V 50Hz	027021	027125	027519	028717	029051	063582
24V 60Hz	059123	059130	059144	059151	059165	063583
110V 50Hz, 120V 60Hz	063520	063530	063540	063550	063560	063570
190V 50Hz, 220V 60Hz	063521	063531	063541	063551	063561	063571
220V 50Hz, 240V 60Hz	063525	063535	063545	063555	063565	063575
230V 50Hz, 240V 60Hz	063522	063532	063542	063552	063562	063572
380V 50Hz, 440V 60Hz	063526	063536	063546	063556	063566	063576
400V 50Hz, 440V 60Hz	063523	063533	063543	063553	063563	063573
415V 50Hz, 480V 60Hz	063524	063534	063544	063554	063564	063574
24V 50/60Hz	063527	063537	063547	063557	063567	063577
110V 50/60Hz	063528	063538	063548	063558	063568	063578
230V 50/60Hz	063529	063539	063549	063559	063569	063579
Special voltages, other than the standard coils listed above <sup>2)</sup>	See price list	See price list	See price list	See price list	See price list	See price list
...V 50Hz (24 – 600V)	105621	105626	105636	105641	105652	101279
...V 60Hz (24 – 600V)	105622	105627	105637	105642	105653	101280

#### Notes

- <sup>1)</sup> To obtain the article number for ordering, read under selected type and actuating voltage from the table above.  
Units with dual voltage coils must be ordered using one article number.
- <sup>2)</sup> When ordering special coils, please state the required actuating voltage from the given range (...-...V).

## System PKZ 2

### Standard Coil Voltages

Undervoltage trips	when ordered with basic device			when ordered separately		
	+U-PKZ2(...)	+U-HI20-PKZ2(...)	+UVHI-PKZ2(...)	U-PKZ2(...)	U-HI20-PKZ2(...)	UVHI-PKZ2(...)
AC	Article No. <sup>1)</sup>	Article No. <sup>1)</sup>	Article No. <sup>1)</sup>	Article No. <sup>1)</sup>	Article No. <sup>1)</sup>	Article No. <sup>1)</sup>
<b>Standard voltage</b>	See price list	See price list	See price list	See price list	See price list	See price list
24V 50Hz	062204	063621	071321	055085	063649	073694
48V 50Hz	012050	063622	012083	023955	063650	000226
240V 50Hz	099850	063623	066661	009717	063652	090399
208/220V 60Hz	063611	063625	063636	063632	063654	063663
110V 50Hz, 120V 60Hz	063612	063626	063637	065686	063655	063664
220V 50Hz, 240V 60Hz	063613	063627	063638	065685	063656	063665
230V 50Hz, 240V 60Hz	065760	065762	065764	065766	065768	065770
380V 50Hz, 440V 60Hz	063614	063628	063639	065689	063657	063666
400V 50Hz, 440V 60Hz	065761	065763	065765	065767	065769	065771
415V 50Hz, 480V 60Hz	063615	063629	063640	065684	063658	063667
24V 50/60Hz	063616	063630	063641	063646	063659	063668
48V 50/60Hz	063617	063631	063642	063647	063660	063669
Special voltages other than the standard coils listed above <sup>2)</sup>	See price list	See price list	See price list	See price list	See price list	See price list
...V 50Hz (24 – 600V)	110162	110164	110167	105919	105913	105928
...V 60Hz (24 – 600V)	110163	110165	110168	105920	105914	105929
<b>DC</b>						
<b>Standard voltage</b>	See price list	See price list	See price list	See price list	See price list	See price list
24V DC	002558	–	–	014463	–	–
48V DC	059510	–	–	028701	–	–
60V DC	050059	–	–	035820	–	–
110/125V DC	063620	–	–	063648	–	–

#### Notes

- <sup>1)</sup> To obtain the article number for ordering, read under selected type and actuating voltage from the table above.  
Units with dual voltage coils must be ordered using one article number.
- <sup>2)</sup> When ordering special coils please state the required actuating voltage from the given range (...-...V).

## System PKZ 2

### Standard Coil Voltages

Remote control drive		
AC, DC	RE-PKZ2(...)	RS-PKZ2(...)
	Article No. <sup>1)</sup>	Article No. <sup>1)</sup>
<b>Standard voltage</b>	See price list	See price list
24V 50/60Hz, DC	063670	063682
42V 50/60Hz, DC	063671	063683
48V 50/60Hz, DC	063672	063684
110 – 120V 50/60Hz, DC	063673	063685
120 – 130V 50/60Hz, DC	063674	063686
190 – 220V 50/60Hz, DC	063675	063687
220 – 240V 50/60Hz, DC	063676	063688
Special voltages	See price list	See price list
60V 50/60Hz, DC	063679	063691
110V 50/60Hz, DC	063680	028912
170 – 190V 50/60Hz, DC	063681	063693
<b>AC</b>		
<b>Standard voltage</b>	See price list	See price list
380 – 415V 50/60Hz	063677	063689
Special voltage	See price list	See price list
440V 50/60Hz	063678	063690

#### Notes

<sup>1)</sup> To obtain the article number for ordering, read under selected type and actuating voltage from the table above.

## System PKZ 2

### Standard Coil Voltages

High capacity magnetic contact module			
Single coil for high capacity magnetic contact module			
AC	S-PKZ2(...)	S/HI20-S-PKZ2(...)	J-S-PKZ2(...)
	Article No. <sup>1)</sup>	Article No. <sup>1)</sup>	Article No. <sup>1)</sup>
<b>Standard voltage</b>	See price list	See price list	See price list
24V 50Hz	026609	056378	035726
48V 50Hz	062651	056383	065114
240V 50Hz	001882	057048	065126
24V 60Hz	062501	056380	065111
110V 50Hz, 120V 60Hz	063694	063701	063723
190V 50Hz, 220V 60Hz	063695	063702	063724
220V 50Hz, 240V 60Hz	063699	063706	063728
230V 50Hz, 240V 60Hz	063696	063703	063725
380V 50Hz, 440V 60Hz	063700	063707	063729
400V 50Hz, 440V 60Hz	063697	063704	063726
415V 50Hz, 480V 60Hz	063698	063705	063727
24V 50/60Hz	062500	056379	065110
110V 50/60Hz	063063	056385	065116
230V 50/60Hz	065103	056395	065125
Special voltages other than the standard coils shown above <sup>2)</sup>	See price list	See price list	See price list
...V 50Hz (24 – 600V)	105905	105909	101845
...V 60Hz (24 – 600V)	105906	105910	101846
<b>DC</b>	<b>S-G-PKZ2(...)</b>		
	Article No. <sup>1)</sup>		
<b>Standard voltage</b>	See price list		
24V DC	070921		
110V DC	218934		
125V DC	203583		

#### Notes

- <sup>1)</sup> To obtain the article number for ordering, read under selected type and actuating voltage from the table above  
Units with dual voltage coils must be ordered using one article number.
- <sup>2)</sup> When ordering special coils please state the required actuating voltage from the given range (...-...V).

# PKZ 2 Motor Protectors Selection Guidelines

## S-PKZ2 high-capacity contact module, SE-PKZ2 contact module

### Normal switching duty

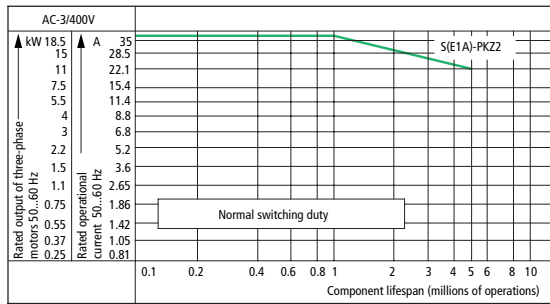

### Squirrel-cage motors

Operating characteristics: Starting: from rest  
Stopping: after attaining full running speed

Typical applications: Compressors Elevators Mixers  
Pumps Escalators Agitators  
Fans Conveyors Centrifuges  
Valves Bucket escalators Air-conditioning

Drives in general for manufacturing and processing machines

Electrical characteristics: Starting: up to 6 x motor rated current  
Stopping: 1 x motor rated current

Utilization category: 100 % AC-3

### Extreme switching duty

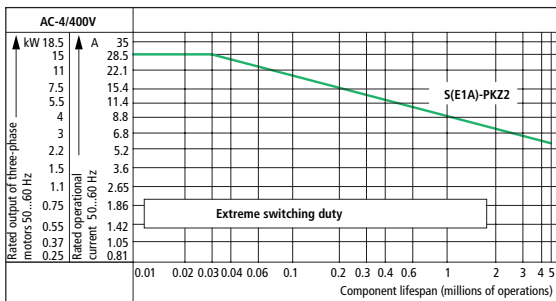

### Squirrel-cage motors

Operating characteristics: Inching, plugging, reversing

Typical applications: Printing machines  
Wire-drawing machines  
Centrifuges  
Special drives for manufacturing and processing machines

Electrical characteristics: Starting: 6 x motor rated current  
Stopping: 6 x motor rated current

Utilization category: 100 % AC-4

### Light switching duty

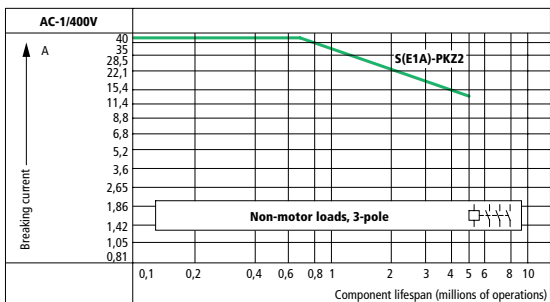

### Non-motor loads

Operating characteristics: Non-inductive or slightly inductive load

Typical applications: Electric heat

Electrical Characteristics: Starting: up to 1.5 x rated current  
Stopping: 1 x rated current

Utilization category: 100 % AC-1

## Determination of the maximum number of operations per hour dependent on the switching capacity and utilization category (approximate values)

$P_N$  = Max. motor rating (HP)

Ops./h = Max. operating frequency per hour

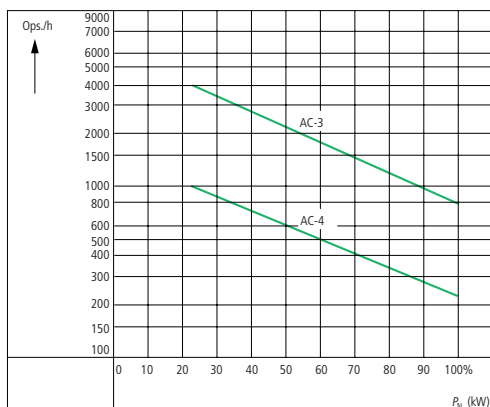

## PKZ 2 Manual Motor Protectors

### Technical Data

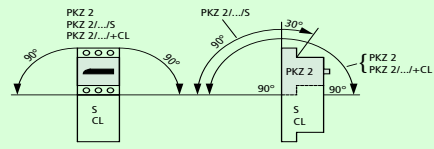
General				
Standards			UL 508, CSA C 22.2 No. 14, IEC/EN 60 947, VDE 0660 GL, LR, DNV, PRS, BV, RINA, RS, EZU, MEEI	
Climatic proofing			Damp heat, constant, to IEC 60 068-2-3 Damp heat, cyclical, to IEC 60 068-2-30	
Ambient temperature	Storage	min./max.	°C	-25/+70
	Open	min./max.	°C	-25/+60
		Enclosed	min./max.	°C
Mounting position				
Direction of incoming supply			as required	
Degree of protection			IP 20	
Shock resistance (half-sinoidal shock 20 ms) to IEC 60 068-2-27		g	Motor protector: 30      Motor protector combination: 8	
Altitude		m	2000	
Terminal capacity				
IEC/EN	solid or stranded	mm <sup>2</sup>	1 × (1 – 16) or 2 × (1 – 6)	
	flexible with ferrule	mm <sup>2</sup>	1 × (1,5 – 10) or 2 × (1,5 – 6)	
UL/CSA	solid or stranded	AWG	14 – 6	
Tightening torque for terminal screws				
Power terminals		Nm	1,8	
Control terminals		Nm	1,0	
Main contacts IEC/EN 60 947 ratings				
Rated impulse withstand voltage $U_{imp}$		V	6000	
Overvoltage category / pollution degree			III/3	
Rated operational voltage $U_e$		V AC	690	
Rated uninterrupted current $I_u =$ rated operational current $I_e$		A	40	
Rated frequency		Hz	50 – 60	
Current heat losses, 3-pole, at operational temperature		W	Motor protector: 14      Motor protector combination: 23	
Lifespan	mechanical	ops.	Motor protector: $0,1 \times 10^6$ (High-capacity) contact module: $5 \times 10^6$ (mechanical lifespan is reduced by 30% for a dual frequency coil 50/60Hz)	
	electrical	100 % AC-3	ops.	Motor protector: $0,05 \times 10^6$ (High-capacity) contact module: $1 \times 10^6$
AC-4		ops.	(High-capacity) contact module: $0,03 \times 10^6$	
Max. operating frequency		ops./h	Motor protector: 60 (High-capacity) contact module: characteristic curve → page 08/058	
Motor switching capacity	AC-3	V AC	max. 690	
		V DC	max. 250	
		A DC	max. 40	
DC application			PKZ2/ZM-..      PKZ2/ZM-../S(+CL)	
Rated short-circuit breaking capacity				
$I_{cn}$ (250 V DC) L/R = 15 ms		kA	30      50	
$I_{cn}$ (125 V DC)		kA	50      65	
Operating times under short-circuit conditions				
Minimum command time		ca. ms	2      2	
Opening delay		ca. ms	0,5      0,5	
Total opening time		ca. ms	6      4	
Trip blocks				
Temperature compensation				
IEC/EN 60 947-4-1		min./max.	°C	-5/+40
Operating range		min./max.	°C	-25/+60
Temperature compensation residual error		%/K		0,25
Magnetic trip tolerance		%		±20
ZM-...PKZ2, ZMR-...PKZ2 motor-protective trip blocks				
Adjustable overload trips		× $I_u$		0,6 – 1,0
Adjustable magnetic trip setting range		× $I_u$		8,5 – 14
Single-phasing sensitivity				UL 508, CSA 22.2 # 14, IEC/EN 60 947-4-1, VDE 0660 part 102

# PKZ 2 Manual Motor Protectors

## Technical Data

### System PKZ2 short-circuit ratings per IEC/EN 60 947 standards for international applications

$I_n$  = Maximum continuous current rating of each device

$I_q$  = Conditional short-circuit current rating (per IEC/EN 60 947-2, relevant for motor starters and motor starter combinations)

$I_{cu}$  = Ultimate braking capacity (per IEC/EN 60 947-2, relevant for circuit breakers)

$I_{cs}$  = Continuity of service breaking capacity (per IEC/EN 60 947-2, relevant for circuit breakers)

All kA ratings are RMS Sym. values

■ Indicates self-protected range(100 kA)

N Not necessary. Backup protection is not required whenever device is operating within its self-protected range or up to the available short-circuit fault

$I_n$ A	230 V				400 V				440 V				500 V				690 V			
	$I_q$ kA	$I_{cu}$ kA	$I_{cs}$ kA	A <sup>1)</sup>	$I_q$ kA	$I_{cu}$ kA	$I_{cs}$ kA	A <sup>1)</sup>	$I_q$ kA	$I_{cu}$ kA	$I_{cs}$ kA	A <sup>1)</sup>	$I_q$ kA	$I_{cu}$ kA	$I_{cs}$ kA	A <sup>1)</sup>	$I_q$ kA	$I_{cu}$ kA	$I_{cs}$ kA	A <sup>1)</sup>
PKZ2/ZM motor protector, coordination type "1" and "2"																				
0,16 – 1,6	■				■				■				■				■			
2,4	■				■				■				■				■			
4	■				■				■				■				■			
6	■				■				■				■				■			
10	■				■				■				■				■			
16	■				■				■				■				■			
25	30	30	7,5	160	30	30	7,5	160	10	10	5	80	7	7	3,5	80	4,5	4,5	2,5	63
32	30	30	7,5	160	30	30	7,5	160	10	10	5	160	7	7	3,5	160	4,5	4,5	2,5	100
40	30	30	7,5	160	30	30	7,5	160	10	10	5	160	7	7	3,5	160	4,5	4,5	2,5	160
PKZ2/ZM motor protector + CL-PKZ2 current limiter, coordination type "1" and "2"																				
0,16 – 1,6	■				■				■				■				■			
2,4	■				■				■				■				■			
4	■				■				■				■				■			
6	■				■				■				■				■			
10	■				■				■				■				■			
16	■				■				■				■				■			
25	30	30	7,5	N	30	30	7,5	N	5	5	3,5	N	3,5	3,5	3,5	N	10	4,5	2,5	N
32	30	30	7,5	N	30	30	7,5	N	5	5	3,5	N	3,5	3,5	3,5	N	10	4,5	2,5	N
40	30	30	7,5	N	30	30	7,5	N	5	5	3,5	N	3,5	3,5	3,5	N	10	4,5	2,5	N
PKZ2/ZM-.../S(-G) high capacity motor protector combination. coordination type "1" and "2"																				
0,6 – 2,4	■				■				■				■				■			
4 – 6	■				■				■				■				■			
10 – 16	■				■				■				■				■			
25 – 40	■				■				■				■				■			

### Notes

<sup>1)</sup> Fuse (A gL/gG) increases the switching capacity of the motor protector to 100 kA

## PKZ 2 Manual Motor Protectors

### Technical Data

S-PKZ2 high-capacity magnetic contactor							
Operating times							
	Closing delay	ms	9 – 30				
	Opening delay	ms	4 – 12				
Duty factor		% DF	100				
Rated making capacity $\cos \varphi = 0,45$		A	400				
Rated breaking capacity $\cos \varphi = 0,45$		A	400				
Magnet systems							
AC operation ( $U_s$ - coil voltage rating)							
Operating range		Pull-in	$\times U_s$	0,85 – 1,1			
		Drop-out	$\times U_s$	0,4 – 0,6			
Power consumption		Pull-in	VA	$\leq 190$			
		Sealing	VA	$\leq 13$			
DC operation (S-G-PKZ2)							
Rated control supply voltage $U_s$		V DC	24	24V DC energization using PLC semi-conductor outputs is possible. Use PLC type: PS416-OUT-410 (HPL 0213-2001/2002, Section 02) and switch two outputs in parallel. The alternative is to use interface relay type ETS4-VS3 (section 02)			
Power consumption							
		Pull-in	VA		150		
		Pull-in	A		6,3 (16 – 22 ms)		
		Sealing	W		2,7		
		Sealing	mA		113		
Auxiliary contacts							
UL/CSA Pilot duty ratings							
NHI, NHI...S			A 600, R 300				
AGM			A 600, R 300				
NHI2-11S, HI...-S			A 600, R 300				
HI11-S/EZ			A 600, R 300				
ZMR			0.5 A @ 300 V AC				
IEC/EN 60 947 ratings							
Rated impulse withstand current $U_{imp}$		V	6000				
Overvoltage category / pollution degree			III/3				
Rated operational voltage $U_e$		V AC	500				
Rated operational current $I_e$							
AC-15			230/240 V	400/415 V	440/500 V		
		NHI11, NHI11S, NHI2-11S, HI11S/EZ	A	6	3	1,5	
		NHI22, NHI22S, HI11S, HI20-S	A	6	1,5	1,5	
		AGM2-11	A	5	3	1,5	
		ZMR... 95 – 96	A	1,5	0,7	0,5	
		ZMR... 97 – 98	A	1,5	0,5	0,3	
DC-13			24 V	60 V	110 V	220 V	
		ZMR... L/R $\leq 200$ ms	A	1	0,8	0,7	0,3
Lifespan							
mechanical		NHI, NHI..S	ops.	0,1 $\times 10^6$			
		AGM	ops.	0,01 $\times 10^6$			
		NHI2-11S, HI...-S, HI11-S/EZ	ops.	5 $\times 10^6$			
		ZMR	ops.	0,01 $\times 10^6$			
electrical		NHI, NHI..S	ops.	0,05 $\times 10^6$			
		AGM	ops.	5 $\times 10^3$			
		NHI2-11S, HI...-S, HI11-S/EZ	ops.	1 $\times 10^6$			
		ZMR	ops.	5 $\times 10^6$			
Control circuit reliability at $U_e = 24$ V DC $U_{min} = 24$ V, $I_{min} = 10$ mA		Fault probability $H_f$	Fail-safe over the entire mechanical lifespan				
Positively driven contacts to ZH 1/457			NHI2-11 S, AGM2-11				
Short-circuit rating without welding		fuseless	with PKZM0 – 6,3: 240 V PKZM0 – 4: 415 V PKZM0 – 1,6: 500 V				
		fuse	A gL/gG	10			
Terminal capacity 1 conductor or 2 conductors							
		solid and flexible with ferrule	IEC/EN	mm <sup>2</sup>	0,75 – 2,5		
		solid or stranded	UL/CSA	AWG	18 – 14		

## PKZ 2 Manual Motor Protectors

### Technical Data

Voltage trips				
Rated impulse withstand voltage $U_{imp}$	V	6000		
Overtoltage category / pollution degree		III/3		
Rated operational voltage $U_e$	V AC	24 – 600		
	V DC	A-PKZ2: 24 – 250, U-PKZ2: 24 – 125		
Terminal capacity 1 conductor or 2 conductors				
solid or flexible with ferrule	IEC/EN	mm <sup>2</sup>	0,75 – 2,5	
solid or stranded	UL/CSA	AWG	22 – 14	
Shunt trips ( $U_s$ = trip coil rated voltage)				
Operating range				
AC	$\times U_s$	0,7 – 1,1		
DC	$\times U_s$	0,7 – 1,1		
Power consumption				
AC Pull-in	VA	5		
	Sealing	VA	3	
DC Pull-in	W	3		
	Sealing	W	0,3	
Undervoltage trips ( $U_s$ = trip coil rated voltage)				
Drop-out voltage	$\times U_s$	0,7 – 0,35		
Power consumption				
AC Pull-in	VA	5		
	Sealing	VA	3	
DC Pull-in	W	3		
	Sealing	W	3	
Drop-out delay with UVHI-PKZ2	ms	200		
Rated operational current $I_e$				
AC-15		230 V	400 V	440 V
U-HI20-PKZ2, UVHI-PKZ2	A	6	3	1,5
UL/CSA Pilot duty rating		B 600, R 300		
Remote control drives RE-PKZ2, RS-PKZ2				
Rated impulse withstand voltage $U_{imp}$	V	6000		
Overtoltage category / pollution degree		III/3		
Rated operational current $U_e$				
AC (50/60 Hz), DC	V	24 – 240 (> 120V, IEC only)		
AC (50/60 Hz)	V	380 – 440 (IEC only)		
Required short-time rating (30 ms)	VA/W	700		
Control transformer short time rating	VA	1100 → STI 0,4		
Short-circuit voltage	%	4,35		
Closing delay	ms	≤ 30		
Opening delay	ms	≤ 30		
Reset time to OFF	ms	≤ 30		
Operating frequency	ops./h	60		
Operating range				
AC	$\times U_s$	0,85 – 1,1		
DC	$\times U_s$	0,85 – 1		
Electrical lifespan				
Integrated auxiliary contact (N.O. 33/34 Hand/Auto indication)				
UL/CSA Pilot duty rating		D 300, R 300		
IEC/EN Rated operational current $I_e$				
AC-14	50 Hz	230/240 V	400/415 V	440 V
	A	1,5	1	0,5
Terminal capacity 1 conductor or 2 conductors				
solid or flexible with ferrule	IEC/EN	mm <sup>2</sup>	0,75 – 2,5	
solid or stranded	UL/CSA	AWG	22 – 14	

## PKZ 2 Manual Motor Protectors

### Technical Data

Three-phase feeder bus connectors		
UL/CSA ratings		
Maximum rated voltage	V AC	600
Maximum rated current		
Type B 3.1/2-PKZ2	A	85
Type B3.1/3-PKZ2	A	100
Bus connector incoming supply terminal		
UL/CSA ratings		
Maximum rated voltage	V AC	600
Maximum rated current Type BK50/3-PKZ2	A	100
Terminal capacities min./max.	AWG	14 ... 0
Torque rating	Nm	4.5

#### PKZ2/ZM(R)-...(S) motor protector trip curve

The trip curve shows the tripping time of the motor protector in relation to the response current. The curve shows mean values of the tolerance ranges at an ambient temperature of 20°C, starting from cold. The tripping time of the bimetal trips at operating temperature (warm state) is reduced to approximately 1/4 of the values shown. System PKZ2 motor protectors are suitable for protection of IEC type EEx e- explosion-proof motors.

Specific characteristics for each individual setting range are available upon request. These characteristics, in 55 x 75 mm format are self-adhesive and can be used as on-site documentation to verify the suitability of each motor protector for this application. The data has been independently verified by the German PTB testing agency and laboratory.

PTB certificate  
No. 3.53/388.299  
Tripping characteristics on  
request

Setting  
range  
A

Tripping  
characteristic to  
AWA No.

0,4 – 0,6	128-881-1
0,6 – 1,0	128-881-2
1,0 – 1,6	128-881-3
1,6 – 2,4	128-881-4
2,4 – 4,0	128-881-5
4,0 – 6,0	128-881-6
6,0 – 10	128-881-7
10 – 16	128-881-8
16 – 25	128-881-9
25 – 32	128-881-10
32 – 40	128-881-11

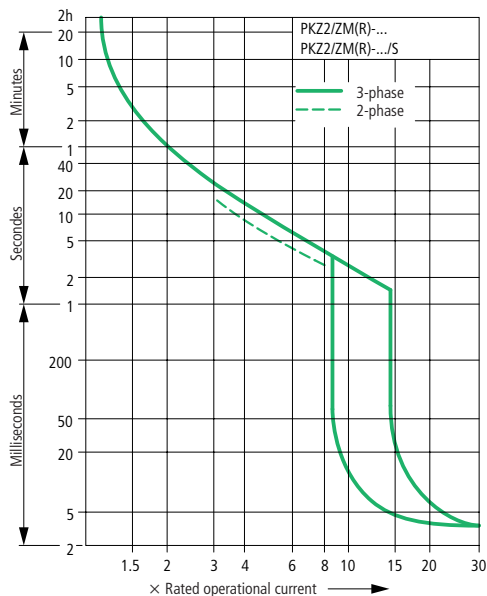

**Circuit diagram**  
for PKZ2/ZMR-...  
and PKZ2/ZMR-.../S

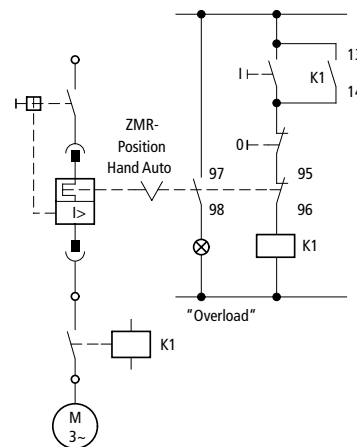

Use of the ZMR-...PKZ2 protective trip module in EEx e applications:

In EEx e applications, the N.C. contact 95-96 of the ZMR protective trip module must always be wired in series with the contactor coil in the starter circuit. See diagram above.

## PKZ 2 Manual Motor Protectors

### Technical Data

UL/CSA Single-phase HP ratings		1-phase HP @	115 V AC	200 V AC	230 V AC		
Always use 3 poles for wiring							
Manual motor protector	PKZ2/ZM-1.6		-	-	1/10		
	PKZ2/ZM-2.4		-	1/8	1/6		
	PKZ2/ZM-4		1/8	1/4	1/3		
	PKZ2/ZM-6		1/4	1/2	1/2		
	PKZ2/ZM-10		1/2	1	1 1/2		
	PKZ2/ZM-16		1	2	2		
	PKZ2/ZM-25		2	3	3		
	PKZ2/ZM-32		2	5	5		
	PKZ2/ZM-40		3	5	7 1/2		
	(High capacity) magnetic contactor	S-PKZ2		3	5	7 1/2	
Three-phase IEC/EN kW ratings (AC-3)		AC-3 kW ratings @	220 V 230 V 240 V	380 V 400 V 415 V	440 V	500 V	660 V 690 V
			kW	kW	kW	kW	kW
Manual motor protector	PKZ2/ZM-0.6		0.09	0.12	0.18	0.25	0.25
	PKZ2/ZM-1		0.18	0.25	0.25	0.37	0.55
	PKZ2/ZM-1.6		0.25	0.55	0.55	0.8	1.1
	PKZ2/ZM-2.4		0.37	0.8	1.1	1.1	1.5
	PKZ2/ZM-4		0.8	1.5	1.5	2.2	3
	PKZ2/ZM-6		1.5	2.5	3	3	4
	PKZ2/ZM-10		2.5	4	5	5.5	7.5
	PKZ2/ZM-16		4	7.5	9	10	13.5
	PKZ2/ZM-25		5.5	12.5	12.5	15	22
	PKZ2/ZM-32		7.5	15	17.5	22	22
Motor protector + contactor combination	PKZ2/ZM-40		11	20	22	24	30
	PKZ2/ZM-0.6/S...		0.09	0.12	0.18	0.25	0.25
	PKZ2/ZM-1/S...		0.18	0.25	0.25	0.37	0.55
	PKZ2/ZM-1.6/S...		0.25	0.55	0.55	0.8	1.1
	PKZ2/ZM-2.4/S...		0.37	0.8	1.1	1.1	1.5
	PKZ2/ZM-4/S...		0.8	1.5	1.5	2.2	3
	PKZ2/ZM-6/S...		1.5	2.5	3	3	4
	PKZ2/ZM-10/S...		2.5	4	5	5.5	7.5
	PKZ2/ZM-16/S...		4	7.5	9	10	13.5
	PKZ2/ZM-25/S...		5.5	12.5	12.5	15	22
PKZ2/ZM-32/S...		7.5	15	17.5	22	22	
PKZ2/ZM-40/S...		11	20	22	24	30	

# PKZ 2 Manual Motor Protectors Dimensions

## Manual motor protector, trip blocks

PKZ2/(Z)M-...,  
ZMR-...-PKZ2

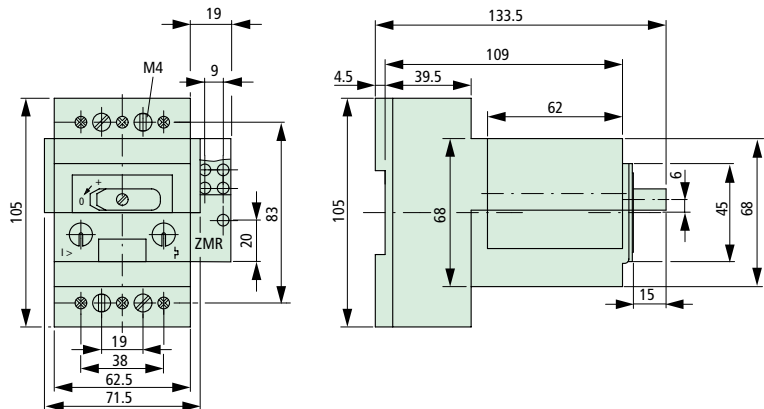

## Trip-indicating auxiliary contact

AGM 2-11-PKZ2

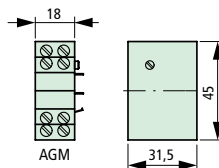

## Standard auxiliary contact

NHI...PKZ2

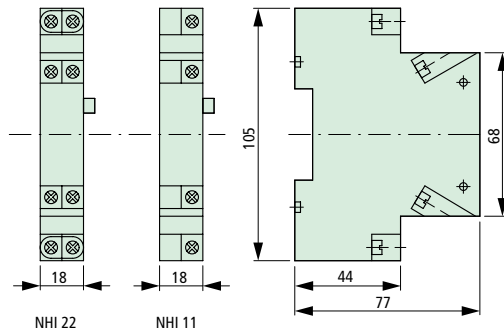

## Remote control drive

RE-PKZ2 (...)  
RS-PKZ2 (...)

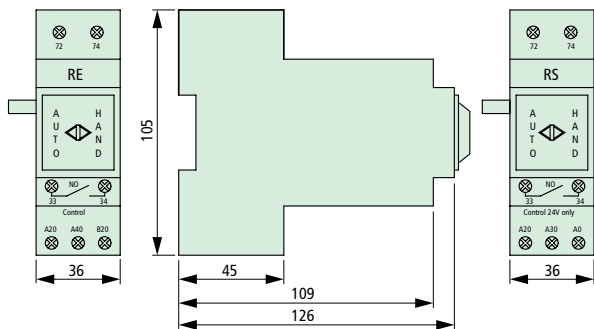

## Voltage trips

U-PKZ2 (...)  
A-PKZ2-...

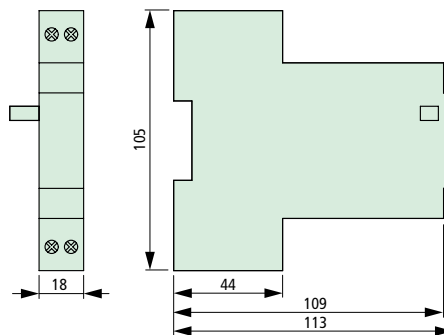

# PKZ 2 Manual Motor Protectors and Motor Protector Combinations

## Dimensions

### High-capacity magnetic motor protector combination

PKZ2/ZM-.../S(-SP)  
PKZ2/ZM-.../S-G

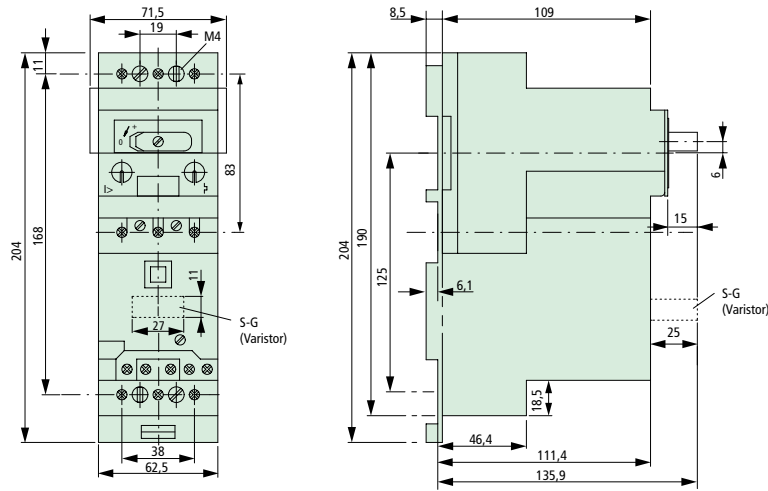

### Standard auxiliary contacts for high-capacity magnetic motor protector combination

NHI...S-PKZ2

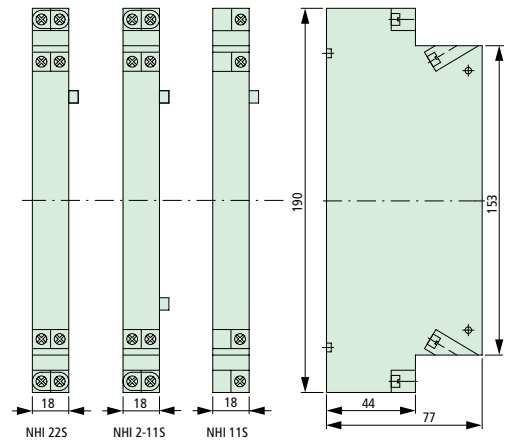

### S(-G) high-capacity contact modules CL current limiters

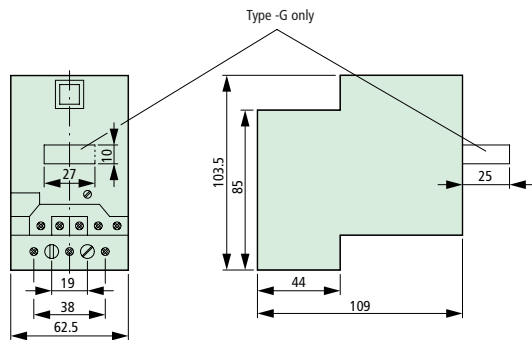

### EZ base for separate mounting HI11-S/EZ standard auxiliary contact for EZ separate mounting

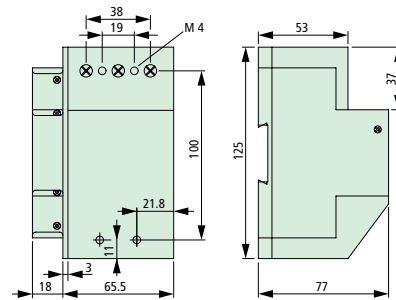

### Enclosure for surface mounting CI19EE-PKZ2-NA

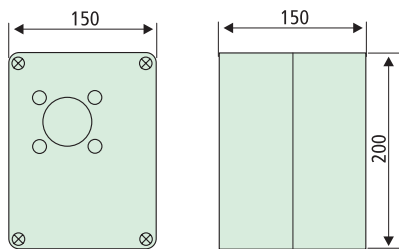

### CS3-PKZ2

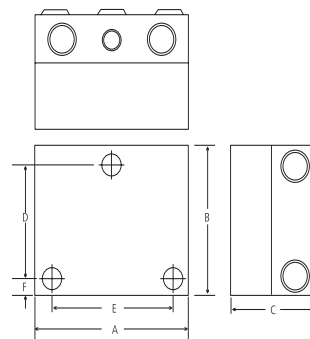

### CI43X-150-PKZ2-SP

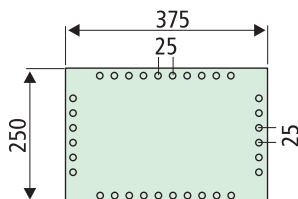

### GKP23-PKZ2

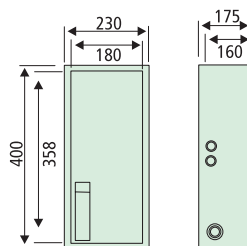

# PKZ 2 Manual Motor Protectors and Motor Protector Combinations

## Dimensions

Door coupling handle  
(R)H-PKZ2

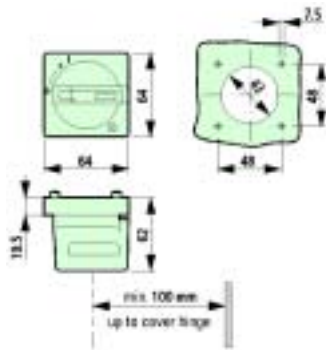

Three-phase feeder bus connector  
B3.1/3-PKZ2

B3.1/2-PKZ2

Terminal  
BK50/3-PKZ2

Cover for unused terminals  
HB-3-PKZ2

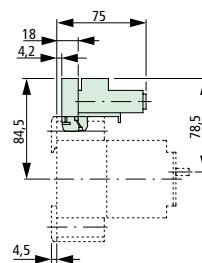
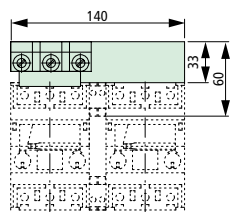
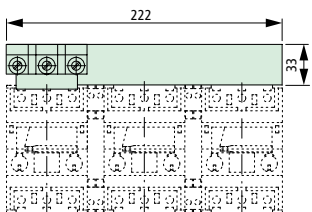

Mechanical interlock for high-capacity contactor modules  
MV-PKZ2

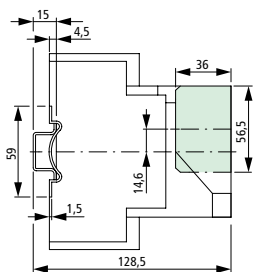
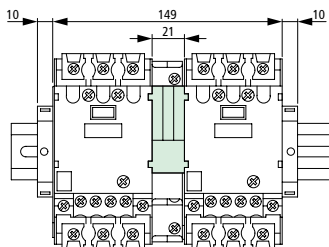

Component adapters

AD40/5(10)-1

AD40/5(10)-2

