

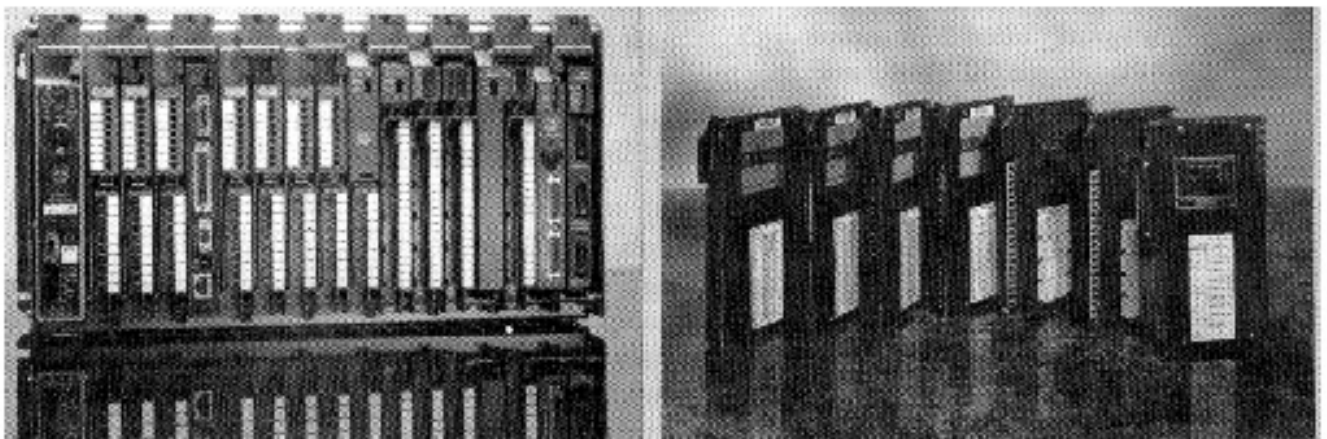

1771 Digital I/O AC Input and Output Modules

Product Data



Interfaces your ON/OFF devices to Allen-Bradley programmable controllers within the 1771 Universal I/O structure. Allen-Bradley digital ac I/O modules interface to ON/OFF devices such as limit switches, pushbuttons, motor starters, pilot lights, and annunciators. These modules are compatible with all current Allen-Bradley programmable controllers. This saves on spare parts, system engineering, inventory, and training costs.

Supports high-power operations. The ac solid-state family of digital I/O modules meets requirements for applications from 10-276V ac. These modules exhibit long life (20 million to over 100 million operations).

Provides system protection and troubleshooting aids. The ac I/O modules include electrical-optical isolation and filter circuits. To help you troubleshoot your system, module indicators are provided to show input or output status.

Table of Contents

AC/DC Input Module (Cat. No. 1771-IA Series C, and 1771-IA2) . . .	<u>12</u>
AC/DC Input Module (Cat. No. 1771-IAD Series D)	<u>14</u>
AC Input Module (Cat. No. 1771-IAN)	<u>16</u>
Isolated AC/DC Input Module (Cat. No.1771-ID)	<u>18</u>
Isolated AC/DC Input Module (Cat. No. 1771-ID01)	<u>20</u>
Isolated AC/DC Input Module (Cat. No 1771-ID16)	<u>22</u>
AC/DC Input Module (Cat. No. 1771-IM)	<u>24</u>
AC/DC Input Module (Cat. No. 1771-IMD Series B)	<u>26</u>
AC Input Module (Cat. No. 1771-IN)	<u>28</u>
AC/DC Input Module (Cat. No. 1771-IND Series B)	<u>30</u>
AC Output Module (Cat. No. 1771-OA Series B)	<u>32</u>
AC Output Module (Cat. No. 1771-OAD Series C)	<u>34</u>
AC Output Module (Cat. No. 1771-OAN)	<u>36</u>
Isolated AC Output Module (Cat. No. 1771-OD Series C)	<u>38</u>
Isolated AC Output Module (Cat. No. 1771-OD16)	<u>40</u>
Isolated AC Output Module (Cat. No. 1771-ODD)	<u>42</u>
Isolated AC Output Module (Cat. No. 1771-ODZ)	<u>44</u>
AC Output Module (Cat. No. 1771-OM)	<u>46</u>
AC Output Module (Cat. No. 1771-OMD Series B)	<u>48</u>
AC Output Module (Cat. No. 1771-ON)	<u>50</u>
AC Output Module (Cat. No. 1771-OND Series B)	<u>52</u>
Protected AC Output Module (Cat. No. 1771-OP)	<u>54</u>
Isolated AC Output Module (Cat. No. 1771-OR Series B)	<u>56</u>
Support Services	<u>59</u>
Technical Support	<u>59</u>
Engineering and Field Services	<u>59</u>
Technical Training	<u>59</u>
Repair and Exchange Services	<u>59</u>

Overview

Understanding the Digital I/O Modules

Allen-Bradley offers a digital I/O product line consisting of three families:

Family	Document
Digital AC Input and Output Modules	1771-2.182
Digital DC Input and Output Modules	1771-2.180
Digital Relay Contact Output Modules	1771-2.181

System Compatibility

The individual specification sheets included in this document show compatibility and use of the data table for each module.

Status Indicators

The front panel of each ac discrete I/O module contains status indicators. Each status indicator shows the ON/OFF condition of an individual input or output. Some modules have additional indicators such as Fuse Blown and/or Triac Fail.

Keying

Plastic keying bands shipped with each I/O chassis let you key your I/O slots to accept only one type of module. You can key any backplane connector in an I/O chassis to receive your module except for the leftmost connector, which is reserved for adapter or processor modules.

Power Supply Requirements

Modules receive power through the 1771 I/O chassis backplane from the associated chassis power supply. Total the current requirements for all the modules in the chassis to avoid overloading the power supply or the I/O chassis backplane.

Module Placement Guidelines

Group your modules to minimize adverse effects from radiated electrical noise and/or heat.

- Group analog input and low voltage dc modules away from ac modules or high voltage dc modules in the chassis to minimize electrical noise interference.
- Place analog input modules and other I/O modules that are sensitive to heat away from slot power supplies to minimize adverse heat effects.

Overview

Addressing Modes

Your Allen-Bradley processor can address its I/O in 2-slot, 1-slot or 1/2-slot I/O groups. You select the addressing method for the chassis in which a processor or I/O adapter resides with the I/O chassis backplane switch assembly. You make the selection for each chassis independently, choosing one method of addressing for each chassis.

Fault Mode Selection

Some digital ac modules let you select last state or reset for input or output failure configuration.

You select one of the two options by positioning a configuration plug (jumper) on the edge of the printed circuit board. This plug is independent of the last state switch on the I/O chassis backplane. You set the jumper to determine whether the module's inputs or outputs do one of the following when the module detects a fault:

- remain in their last state
- are turned off (reset)

When the input module detects a fault, its input-image bits are put into the state indicated by the jumper position. When the output module detects a fault its outputs are put into the state indicated by the jumper position. Refer to the table below for the state of inputs or outputs after a module detects a fault, and jumper settings.

Jumper Settings and the State of Inputs or Outputs

If you want module inputs and outputs to:	Set jumper to:
Stay in their last state when a module detects a fault	last state (LS)
Reset to off when a module detects a fault	reset

For instructions on how to set the configuration jumper on those modules that allow you to select the fault mode, refer to the individual module specification sheets.

AC Input Modules

1771 digital ac input modules convert ac signals from user devices to the appropriate logic level for use within the processor. Typical input devices include:

- proximity switches
- limit switches
- selector switches
- float switches
- pushbutton switches

Overview

Allen-Bradley ac input modules are available with a wide range of input terminals per module. The table below lists the Allen-Bradley ac input modules, the image bits per module and addressing modes you can use with the I/O chassis and chassis compatibility for each input module.

Data Table Usage and I/O Chassis Compatibility for ac Input Modules

Module Type and Catalog Number	Series	Use of Data Table		Addressing			Compatible Chassis
		Input Image Bits	Output Image Bits	1/2-Slot	1-Slot	2-Slot	
AC Input Modules							
1771-IA Module	C	8		Y	Y	Y	A, B
1771-IA2 Module	A	8		Y	Y	Y	A, B
1771-IAD Module	D	16		Y	Y	R	B
1771-IAN Module	A	32		Y	R	N	B
1771-ID Module	A	8		Y	Y	Y	A, B
1771-ID01 Module	A	8		Y	Y	Y	A, B
1771-ID16 Module	A	16		Y	Y	R	B
1771-IM Module	A	8		Y	Y	Y	A, B
1771-IMD Module	B	16		Y	Y	R	B
1771-IN Module	A	8		Y	Y	Y	A, B
1771-IND Module	B	16		Y	Y	R	B

A = Compatible with superseded chassis (1771-A1, -A2, -A4)
 B = Compatible with current chassis (1771-A1B, -A2B, -A3B, -A3B1, -A4B, -AM1, -AM2)
 Y = Compatible without restriction
 R = Conditional module placement; you must use an input module and an output module in two adjacent slots (even/odd) of the I/O chassis beginning with slot 0.
 N = Not compatible

Input Filtering

Input filtering limits the effect of voltage transients caused by contact bounce and/or electrical noise. If not filtered, voltage transients could produce false data.

Backplane circuits, module logic circuits, and the rest of the system are protected from possible damage due to electrical transients by opto-electrical isolation.

Certain modules allow you to configure filter times. Refer to the individual module specifications in this document for more information.

Overview**AC Output Modules**

1771 digital ac output modules contain the output circuitry necessary to control the ON/OFF status of ac user devices. Typical output devices compatible with your output module include:

- ac motor starters
- solenoids
- indicators

The Allen-Bradley ac digital output modules, their image bits per module, the addressing modes you can use with I/O chassis and chassis compatibility for each output module are shown below.

Data Table Usage and I/O Chassis Compatibility for ac Output Modules

Module Type and Catalog Number	Series	Input Image Bits	Output Image Bits	1/2-Slot	1-Slot	2-Slot	Compatible Chassis
AC Output Modules							
1771-OA Module	B		8	Y	Y	Y	A, B
1771-OAD Module	C	See note	16	Y	Y	R	B
1771-OAN Module	A		32	Y	R	N	B
1771-OD Module	C		8	Y	Y	Y	A, B
1771-OD16 Module	A		16	Y	Y	R	B
1771-ODD Module	A		16	Y	Y	R	B
1771-ODZ Module	A		8	Y	Y	Y	A, B
1771-OM Module	A		8	Y	Y	Y	A, B
1771-OMD Module	B		16	Y	Y	R	A, B
1771-ON Module	A		8	Y	Y	Y	A, B
1771-OND Module	B		16	Y	Y	R	B
1771-OP Module	A		8	Y	Y	Y	A, B
1771-OR Module	B		8	Y	Y	Y	A, B

A = Compatible with superseded chassis (1771-A1, -A2, -A4)

B = Compatible with current chassis (1771-A1B, -A2B, -A3B, -A3B1, -A4B, -AM1, -AM2)

Y = Compatible without restriction

R = Conditional module placement; you must use an input module and an output module in two adjacent slots (even/odd) of the I/O chassis beginning with slot 0.

N = Not compatible

NOTE: Uses input image table bits for fuse-blown indication when internal jumper is set to CSI position. Do not use module in complementary mode when jumper is in CSI position.

Surge Suppression

Output modules contain surge suppression circuitry for the output triacs. The output modules provide a metal-oxide varistor (MOV) between each set of terminals to suppress high-voltage transients from the ac line. In each output circuit, an RC network limits the magnitude of voltage transients that may occur when a device is wired in parallel or series with hard contacts.

Overview

Important: We recommend that you use an additional suppression device if an output module is being used to control an inductive device such as:

- relays
- motor starters
- solenoids
- motors

and is in series with or parallel to a “hard contact” such as:

- pushbuttons
- selector switches

By adding a suppression device directly across the coil of an inductive device, you will prolong the life of the switch contacts. The diagram below shows an output module with a suppression device.

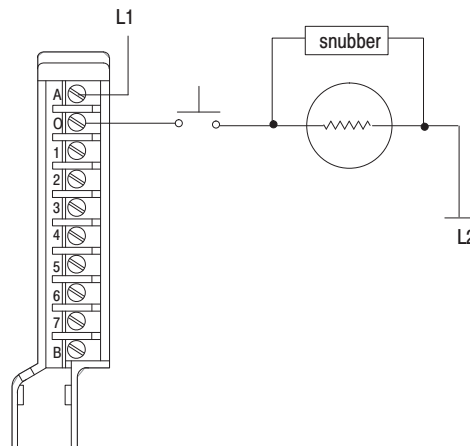

12346-I

The impedance characteristic is the most important factor in selecting a suppression device; thus no single suppression device can be recommended for every possible load. Acceptable Allen-Bradley suppression devices and their catalog numbers for typical loads are shown below.

Allen-Bradley Suppression Devices

Suppression Device	Catalog Number
Motor Starter Bulletin 509	599-K04 ¹
Motor Starter Bulletin 709	1401-N10 ¹
Relay Bulletin 700 Type N or P	700-N24 ²
Miscellaneous	700-N24 ³

¹ For starters with 120V ac coils

² Maximum coil voltage 150V ac or dc

³ Bulletin 700-N24 is a universal surge suppressor. You can use it on electromagnetic devices with the limitation of 35 sealed VA, 150V.

Overview
Fuses

The outputs on most modules are fused to protect module circuitry from overload. Some module outputs are individually fused and some modules have one fuse for all module circuits.

Fused Wiring Arm Information

The optional Fused Wiring Arm (1771-WHF or -WHFB) provides fuse protection for each output. It also allows simple fuse replacement without removing the wiring arm from the I/O chassis. You can use this wiring arm as an alternative to the 1771-WH Wiring Arm.

Replacement Fuse Kits

Allen-Bradley provides optional fuse kits for output modules. Refer to the Table below for descriptions and usage.

Use with:	Kit Catalog Number	Kit Contents
8-point output modules	1771-FC	5 each of the following: 125 Volt, 2A 250 Volt, 2A Slow Blow 250 Volt, 2A Normal Blow 25 Volt, .032A
16-point output modules using the nonfused 1771-WH field wiring arm		5 each of the following: 125 Volt, 2A 250 Volt, 2A Slow Blow 250 Volt, 2A Normal Blow 25 Volt, .032A
1771-WHF Field Wiring Arm	1771-FD	8 2AG 3A fuses; 2 fuse holders
1771-WHFB Field Wiring Arm	1771-FD2	8 2AG 1.5A fuses; 2 fuse holders

Overview

Compliance to European Union Directives

If this product has the CE mark it is approved for installation within the European Union and EEA regions. It has been designed and tested to meet the following directives.

EMC Directive

This product is tested to meet Council Directive 89/336/EEC Electromagnetic Compatibility (EMC) and the following standards, in whole or in part, documented in a technical construction file:

- EN 50081-2EMC – Generic Emission Standard, Part 2 – Industrial Environment
- EN 50082-2EMC – Generic Immunity Standard, Part 2 – Industrial Environment

This product is intended for use in an industrial environment.

Low Voltage Directive

This product is tested to meet Council Directive 73/23/EEC Low Voltage, by applying the safety requirements of EN 61131-2 Programmable Controllers, Part 2 – Equipment Requirements and Tests.

For specific information required by EN 61131-2, see the appropriate sections in this publication, as well as the following Allen-Bradley publications:

- Industrial Automation Wiring and Grounding Guidelines For Noise Immunity, publication 1770-4.1
- Guidelines for Handling Lithium Batteries, publication AG-5.4
- Automation Systems Catalog, publication B111

Agency Certification

Individual discrete I/O modules can also comply with various other agency requirements when product or packaging is so marked.

Agency Certification (when product or packaging is marked)	<ul style="list-style-type: none"> • CSA certified • CSA Class I, Division 2, Groups A, B, C, D certified • UL listed • CE marked for all applicable directives
---	---

Overview**Associated Publications**

Each input and output module ships with an installation instruction. The table below lists the modules and associated publications.

Associated Publications

Module Type	Installation Instructions
AC Input Modules	
1771-IA/-IA2 Module	1771-2.1
1771-IAD Module	1771-5.23
1771-IAN Module	1771-5.32
1771-ID Module	1771-2.19
1771-ID01 Module	1771-2.102
1771-ID16 Module	1771-2.189
1771-IM Module	1771-2.20
1771-IMD Module	1771-2.104
1771-IN Module	1771-2.41
1771-IND Module	1771-2.96
AC Output Modules	
1771-OA Module	1771-2.5
1771-OAD Module	1771-5.24
1771-OAN Module	1771-5.31
1771-OD Module	1771-2.12
1771-OD16 Module	1771-2.190
1771-ODD Module	1771-5.20
1771-ODZ Module	1771-2.130
1771-OM Module	1771-2.18
1771-OMD Module	1771-5.26
1771-ON Module	1771-2.42
1771-OND Module	1771-5.41
1771-OP Module	1771-2.23
1771-OR Module	1771-2.40

Overview**Where to Look**

For specifications for individual modules, refer to the table below.

Module Type	Refer to:
AC Input Modules	
1771-IA/-IA2 Module	Page 11
1771-IAD Module	Page 13
1771-IAN Module	Page 15
1771-ID Module	Page 17
1771-ID01 Module	Page 19
1771-ID16 Module	Page 21
1771-IM Module	Page 23
1771-IMD Module	Page 25
1771-IN Module	Page 27
1771-IND Module	Page 29
AC Output Modules	
1771-OA Module	Page 31
1771-OAD Module	Page 33
1771-OAN Module	Page 35
1771-OD Module	Page 37
1771-OD16 Module	Page 39
1771-ODD Module	Page 41
1771-ODZ Module	Page 43
1771-OM Module	Page 45
1771-OMD Module	Page 47
1771-ON Module	Page 49
1771-OND Module	Page 51
1771-OP Module	Page 53
1771-OR Module	Page 55

AC/DC Input Module (Cat. No. 1771-IA Series C, and 1771-IA2)

Simplified Schematic

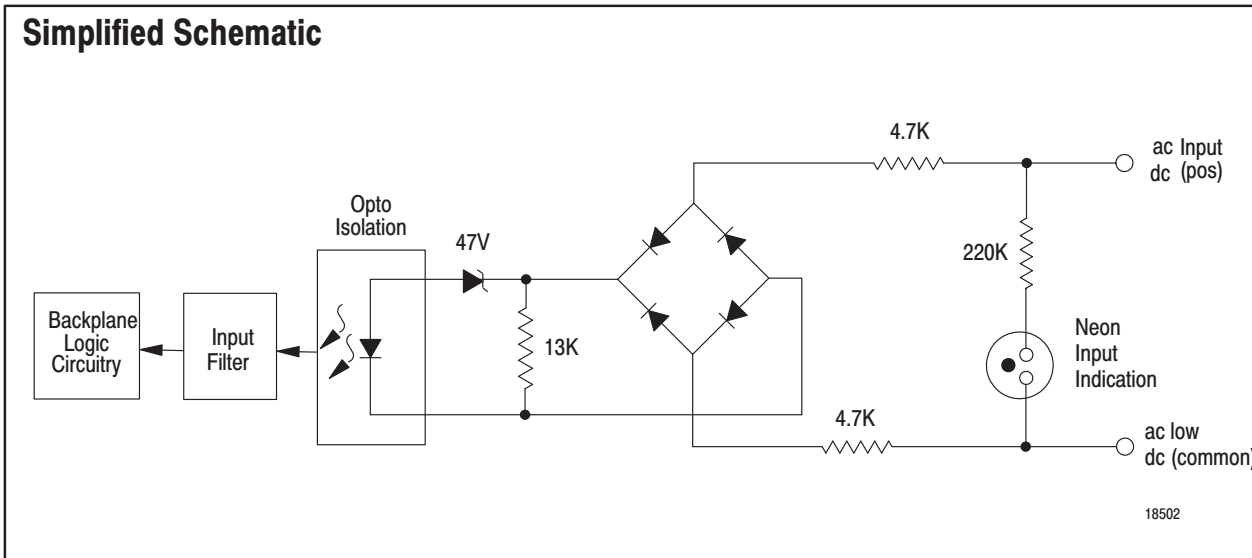

Application Notes

Device Compatibility. This module is designed to operate with ac proximity switches such as Allen-Bradley Bulletin 871P and other input devices with an off-state leakage current less than 2.8mA.

Connection to Output Modules. You can use an ac (120V) output module (cat. no. 1771-OA) to directly drive terminals on an ac/dc (120V) input module (cat. no. 1771-IA, IA2), but you must connect a 2.5K ohm, 10W resistor or an electrocube snubber (part number RG-1676-1) between the output terminal and L2 (ac low). Use the same power source to power both modules to ensure proper phasing and to prevent module damage.

Status Indicators. The front panel has eight orange status indicators. The indicators are provided for field side indication of individual inputs. When an indicator is illuminated, voltage is present on the terminal. The module transfers this information to the backplane for the processor to read.

Inrush Current Considerations. The peak inrush current at turn-on can be calculated as follows:

$$\text{Peak inrush current} = (V_{PS} - 47)/9.4K \text{ ohms}$$

Where: V_{PS} = customer supply peak voltage

Connection Diagram

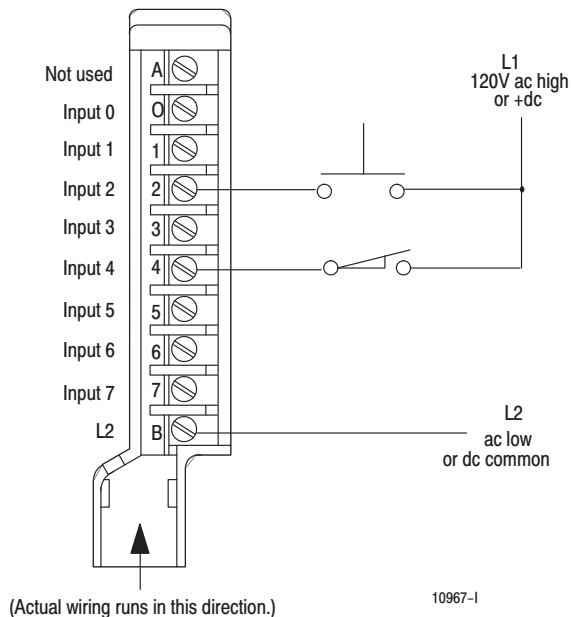

AC/DC Input Module (Cat. No. 1771-IA Series C, and 1771-IA2)

Specifications (Cat. No. 1771-IA/C, -IA2)	
Inputs per Module	8
Module Location	1771 I/O chassis
Nominal Input Voltage	120V ac @ 47 – 63Hz 125V dc
Nominal Input Current	6.83mA @ 120V ac 50Hz 7.9mA @ 120V ac 60Hz 7.4mA @ 125V dc
On-state Voltage Range	87V ac to 138V ac 97V dc to 138V dc
On-state current (minimum)	5.2mA
Off-state Voltage (maximum)	46V ac peak 57V dc
Off-state Current (maximum)	2.8mA ac peak or dc
Input Impedance	Refer to simplified schematic
Input Signal Delay	Off to On On to Off
	24±10ms for ac 10±4ms for dc 24±10ms for ac 20±9ms for dc
Power Dissipation	10.7 Watts (max.), 0.4 Watts (min.)
Thermal Dissipation	36.5 BTU/hr (max.), 1.4 BTU/hr (min.)
Backplane Current	75mA
Isolation Voltage	Isolation meets or exceeds UL Standard 508, and CSA Standard C22.2 No. 142.
Environmental Conditions	
Operational Temperature	0° to 60°C (32° to 140°F)
Storage Temperature	-40° to 85°C (-40° to 185°F)
Relative Humidity	5 to 95% without condensation
Conductors	Wire Size Category
	14 gauge (2mm ²) stranded maximum 3/64 inch (1.2mm) insulation maximum 1 ¹
Keying	Between 4 and 6 Between 10 and 12
Field Wiring Arm	Catalog Number 1771-WA
Wiring Arm Torque	7-9 inch-pounds
Agency Certification (when product or packaging is marked)	<ul style="list-style-type: none"> • CSA certified • CSA Class I, Division 2, Groups A, B, C, D certified • UL listed • CE marked for all applicable directives
Installation Instructions	1771-2.1

¹ You use this conductor-category information for planning conductor routing as described in the system-level installation manual

Status Indicators

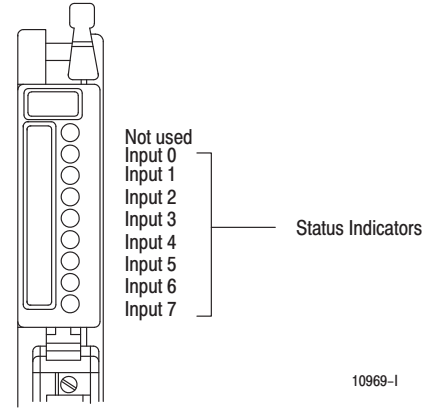

Sample Connection Diagram – Driving a 1771-IA Module with a 1771-OA Module

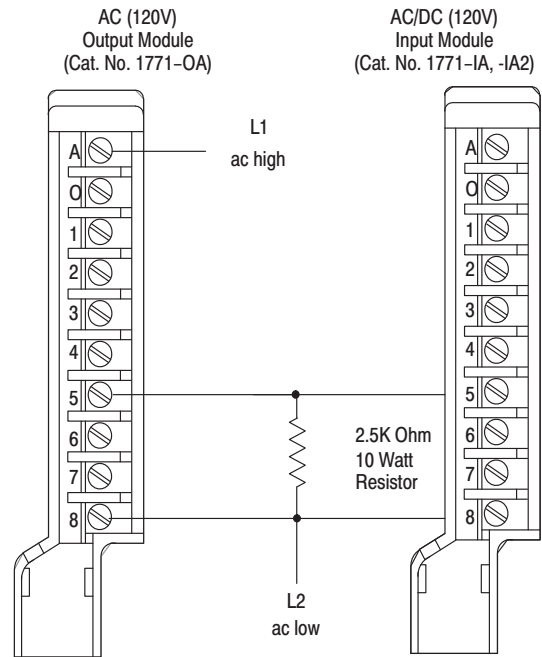

AC/DC Input Module (Cat. No. 1771-IAD Series D)

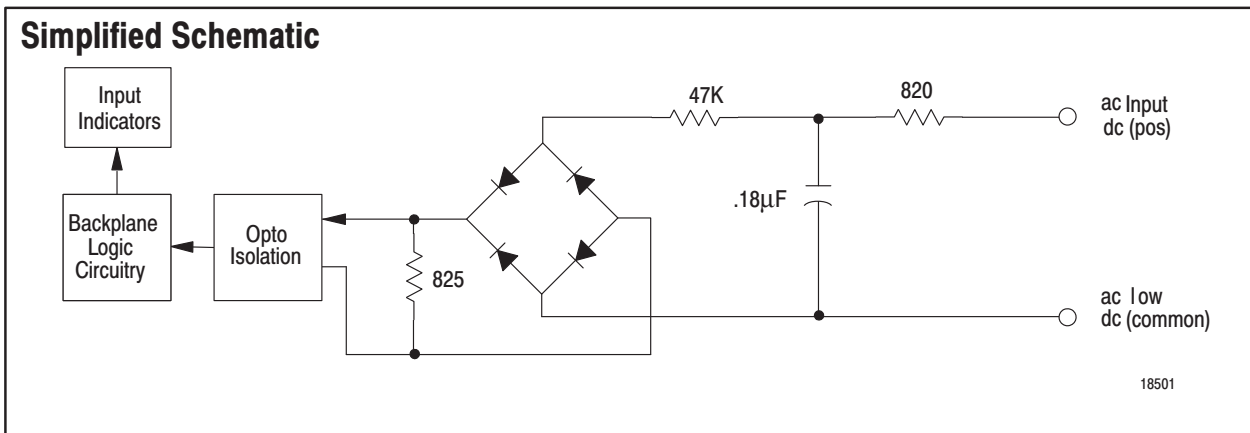

Application Notes

Product Compatibility. This module must be used with a 1771-A1B thru -A4B or later I/O chassis.

Connection to Output Modules. You can use an ac (120V) output module (cat. no. 1771-OAD) to directly drive terminals on an ac/dc (120V) input module (cat. no. 1771-IAD). You can use a 1771-OA output module to drive an ac/dc (120V) input module (cat. no. 1771-IAD), but you must connect a 2.5K ohm, 10W resistor or an electrocube snubber (part number RG-1676-1) between the output terminal and L2 (common). Use the same power source to power both modules to ensure proper phasing and to prevent module damage.

Setting the Delay Time Jumper. Use the jumper located at the top of the circuit board to set the delay time to 5ms (typical) or 20ms (for high noise environments).

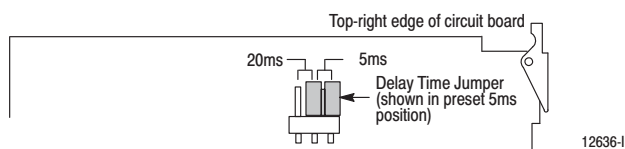

Status Indicators. The front panel has one green module active indicator, and 16 red status indicators. Once the 5V dc backplane voltage has stabilized, the green module active indicator is illuminated. Each status indicator provides system logic side indication of individual inputs. When an indicator is illuminated, voltage is present on the terminal.

Inrush Current Considerations. Due to capacitive impedance input, there is an initial current associated with the 1771-IAD. The peak inrush current at turn-on can be calculated as follows:

Peak Inrush Current = $V_{PS}/820$ ohm
 where: V_{PS} = customer supply peak voltage.

Connection Diagram

Terminal A must be connected to L1 to balance the line in ungrounded applications or for additional filtering of noise in grounded systems.

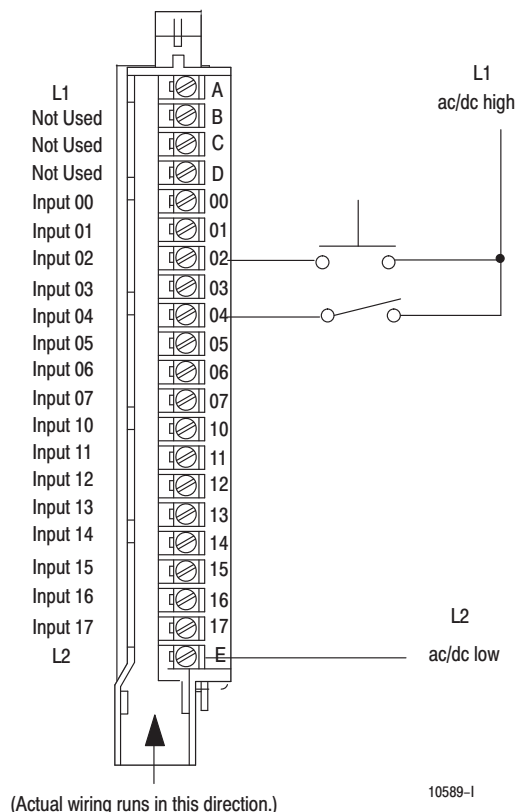

AC/DC Input Module (Cat. No. 1771-IAD Series D)

Specifications (Cat. No. 1771-IAD Series D)

Inputs per Module	16
Module Location	1771-A1B thru -A4B or later I/O chassis, 1771-AM1, -AM2 chassis
Nominal Input Voltage	120V ac@ 50/60Hz; 125V dc
Nominal Input Current	8.7mA @ 120V ac 50Hz 9.9mA @ 120V ac 60Hz 2.56mA @ 125V dc
On-state Voltage Range	79V ac to 138V ac or dc
On-state Current (minimum)	5.95mA @ 79V ac 60Hz 1.5mA @ 79V dc
Off-state Voltage (maximum)	43V ac peak 43V dc
Off-state Current (maximum)	3.0mA @ 43V ac 60Hz; 0.8mA @ 43V dc
Input Impedance	11.2K Ohms @ 60Hz (0.18 microfarad in parallel with 47K Ohms, in series with 820 ohms)
Input Signal Delay	Off to On: 120V ac/60Hz: 5ms (±3ms) or 20ms(±5ms) selectable 120V dc: 3ms (±0.1ms) or 10ms (±1ms) selectable On to Off: 25ms (±5ms) for 120V ac or dc
Power Dissipation	8.8 Watts (max.), 1.0 Watts (min.)
Thermal Dissipation	30.1 BTU/hr (max.), 3.42 BTU/hr (min.)
Backplane Current	195mA @ 5V
Isolation Voltage	Isolation meets or exceeds UL Standard 508, and CSA Standard C22.2 No. 142.
Environmental Conditions	Operational Temperature: 0° to 60°C (32° to 140°F) Storage Temperature: -40° to 85°C (-40° to 185°F) Relative Humidity: 5 to 95% without condensation
Conductors Wire Size	14 gauge (2mm ²) stranded maximum 3/64 inch (1.2mm) insulation maximum
Category	1 ¹
Keying	Between 10 and 12 Between 14 and 16
Field Wiring Arm	Catalog Number 1771-WH
Wiring Arm Screw Torque	7-9 inch-pounds
Agency Certification (when product or packaging is marked)	<ul style="list-style-type: none"> • CSA certified • CSA Class I, Division 2, Groups A, B, C, D certified • UL listed • CE marked for all applicable directives
Installation Instructions	1771-5.23

¹ You use this conductor-category information for planning conductor routing as described in the system-level installation manual

Status Indicators

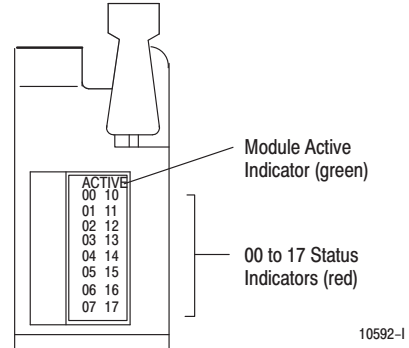

Sample Connection Diagram – Driving a 1771-IAD Module with a 1771-OAD Module

AC (12-120V) Output Module (Cat. No. 1771-OAD) AC/DC (120V) Input Module (Cat. No. 1771-IAD)

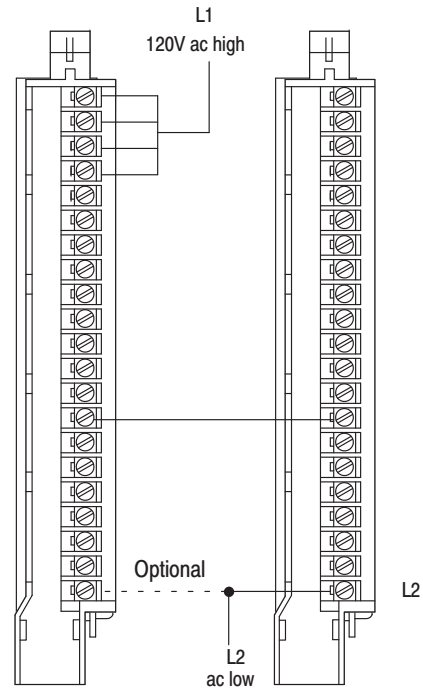

Note: 1771-OAD output voltage range is 10-138V ac. However, the on-state voltage range of the 1771-IAD is 77-138V ac.

10591-1

AC Input Module (Cat. No. 1771-IAN)

Simplified Schematic

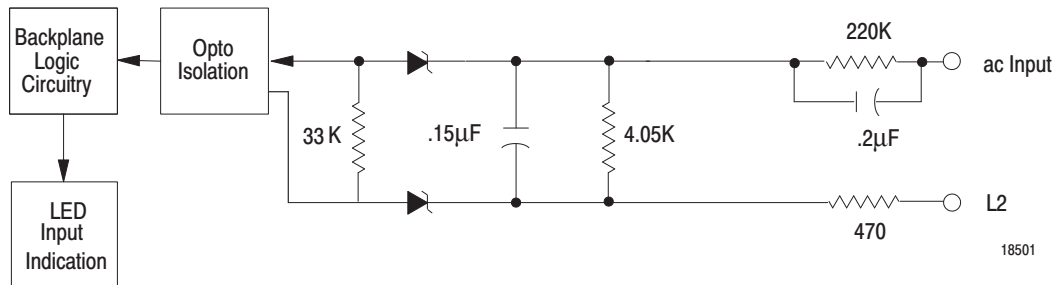

Application Notes

Product Compatibility. This module must be used with a 1771-A1B thru -A4B or later I/O chassis. If you are using 1/2-slot addressing, you can use any combination of I/O modules. When using 1-slot addressing, make sure no other input module or single slot block transfer module is placed in the same I/O group. This module is not compatible with 2-slot addressing.

Connection to Output Modules. You can use an ac (120V) output module (cat. no. 1771-OAN) to directly drive terminals on an ac/dc input module (cat. no. 1771-IAN). You can also use a 1771-OAD or -OA output module to drive an ac/dc (120V) input module (cat. no. 1771-IAN), but you must connect a 2.5K ohm, 10W resistor or an electrocube snubber (part number RG-1676-1) between the output terminal and L2 (common). **Use the same power source to power both modules to ensure proper phasing and to prevent module damage.**

Status Indicators. The front panel has 32 red status indicators. Each status indicator provides system logic side indication of an individual input. When an indicator is illuminated, voltage is present on the terminal. The module transfers this information to the backplane for the processor to read.

Inrush Current Considerations. Due to capacitive impedance input, there is an initial current associated with the 1771-IAN. The peak inrush current at turn-on can be calculated as follows:

$$\text{Peak Inrush Current} = (V_{PS} - 17)/470 \text{ ohms}$$

where: V_{PS} = customer supply peak voltage.

Connection Diagram

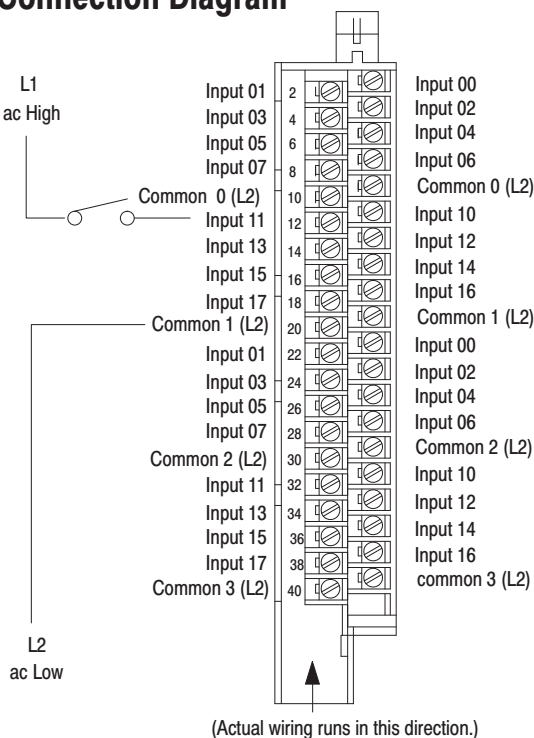

Note: Terminals on the left are even numbered (2 thru 40), and terminals on the right are odd numbered (1 thru 39).

(See applicable codes and laws.)

11854-1

AC Input Module (Cat. No. 1771-IAN)

Specifications (Cat. No. 1771-IAN)

Inputs per module	32 (4 groups of 8)	
Module Location	1771-A1B thru -A4B or later I/O Chassis 1771-AM1, -AM2 Chassis	
Nominal Input Voltage	120V ac	
Voltage Range	85 to 138V ac, 50/60Hz	
Nominal Input Current	8.2mA @ 115V ac, 60Hz 6.8mA @ 115V ac, 50Hz	
On-state Current (minimum)	5.2mA @ 85V ac, 60Hz 4.2mA @ 85V ac, 50Hz	
Off-state Current (maximum)	2.3mA @ 30V ac, 60Hz 1.9mA @ 30V ac, 50Hz	
Off-state Voltage (maximum)	30V ac	
Input Impedance	0.2uF in parallel with 220K ohms (13.3K ohms @ 60Hz); in series with 470 ohms	
Input Signal Delay	Off to On On to Off	10.0ms (±7ms) 20.0ms (±15ms)
Isolation Voltage	Isolation meets or exceeds UL Standard 508, and CSA Standard C22.2 No. 142.	
Power Dissipation	7.0W (max); 1.0W (min)	
Thermal Dissipation	24.1 BTU/hr (max); 3.4 BTU/hr (min)	
Backplane Current	280mA @ 5V DC maximum	
Environmental Conditions		
Operational Temperature	0° to 60°C (32° to 140°F)	
Storage Temperature	-40° to 85°C (-40° to 185°F)	
Relative Humidity	5 to 95% (without condensation)	
Conductors Wire Size	14 gauge (2mm ²) stranded (max) ² 3/64 inch (1.2mm) insulation (max)	
Category	1 ¹	
Keying	Between 16 and 18 Between 20 and 22	
Field Wiring Arm	1771-WN	
Wiring Arm Screw Torque	7-9 inch pounds	
Agency Certification (when product or packaging is marked)	<ul style="list-style-type: none"> • CSA certified • CSA Class I, Division 2, Groups A, B, C, D certified • UL listed • CE marked for all applicable directives 	
Installation Instructions	1771-5.32	

¹ You use this conductor-category information for planning conductor routing as described in the system-level installation manual.

² 14 gauge wire connected to all terminals may not allow the field wiring arm cover to close. A smaller gauge wire may be required.

Status Indicators

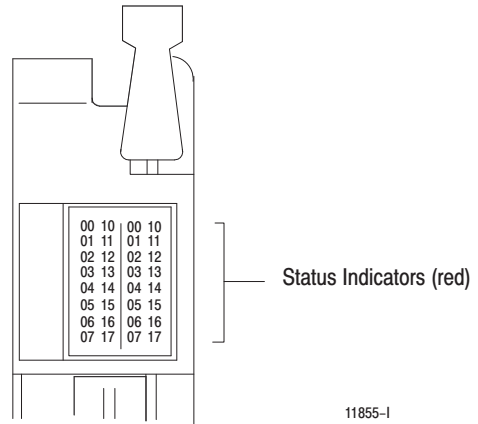

Sample Connection Diagram – Driving a 1771-IAN Module with a 1771-OAN Module

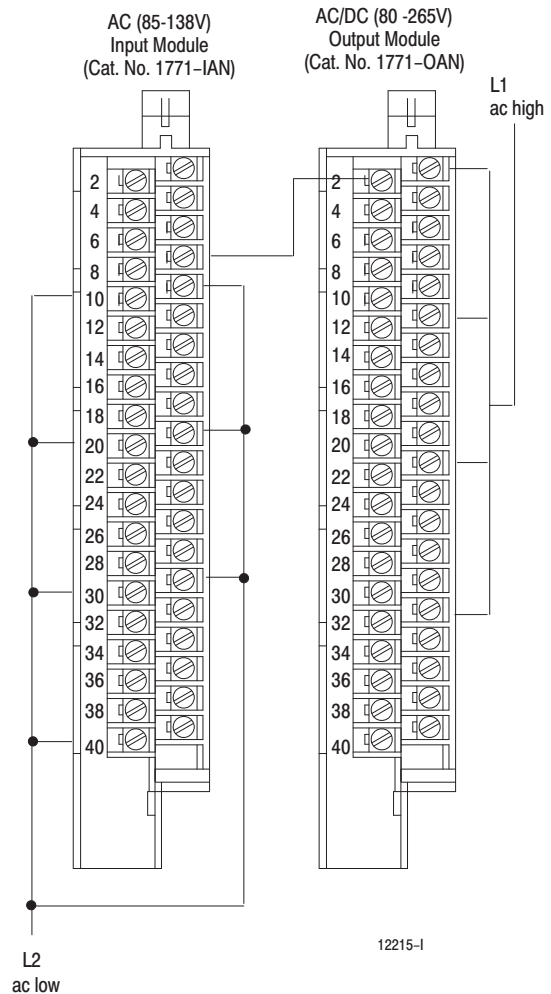

Isolated AC/DC Input Module (Cat. No.1771-ID)

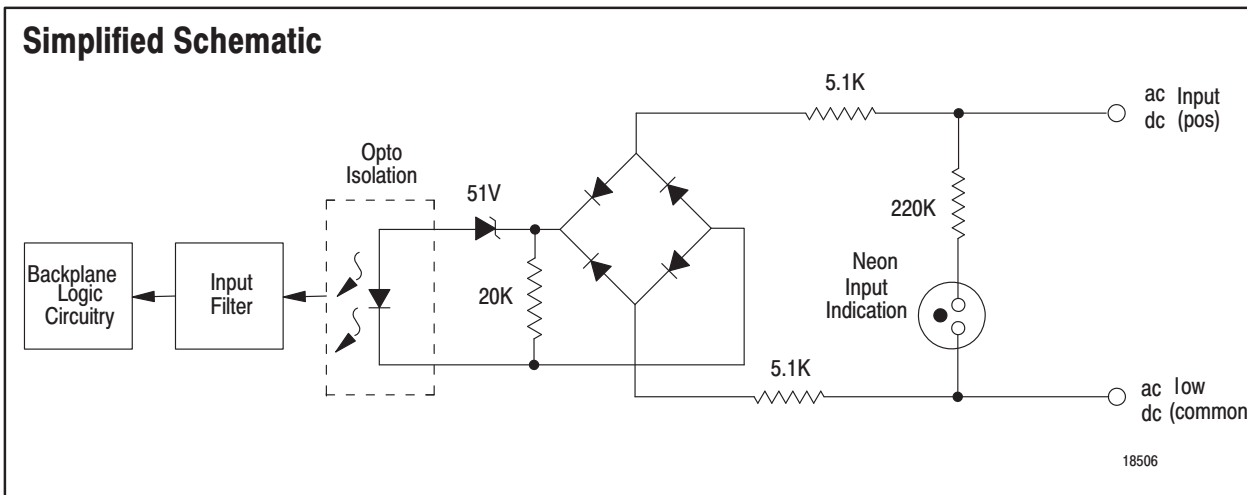

Application Notes

Device Compatibility. This module is designed to operate with limit switches, float switches, selector switches, and pushbutton switches.

Connection to Output Modules. You can use an ac output module (cat. no. 1771-OA, -OAD, -OD, or -OP) to directly drive terminals on an ac/dc (120V) input module (cat. no. 1771-ID), but you must connect a 2.5K ohm, 10W resistor or an electrocube (part number RG-1676-1) between the output terminal and L2 (common). Use the same ac power source to power both modules to ensure proper phasing and to prevent module damage.

Status Indicators. The front panel has 6 red status indicators. Each status indicator is illuminated when its corresponding circuit has ac/dc voltage applied to it. The indicators are provided for field side indication of individual inputs.

Inrush Current Considerations. The peak inrush current at turn-on can be calculated as follows:

$$\text{Peak inrush current} = (V_{PS} - 52)/10K \text{ ohms}$$

Where: V_{PS} = customer supply peak voltage

Connection Diagram

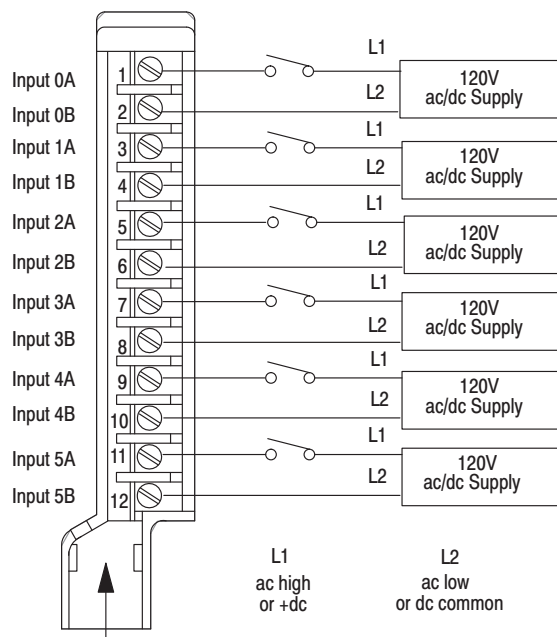

Actual wiring runs in this direction.

10437-1

Isolated AC/DC Input Module (Cat. No.1771-ID)

Specifications (Cat. No. 1771-ID)	
Inputs per Module	6
Module Location	1771 I/O chassis
On-state Voltage Range	92-138V ac/dc, 47-63Hz
Nominal Input Current	6.91mA @ 120V ac 50Hz 8.0mA @ 120V ac 60Hz 8.0mA @ 120V dc
Input Signal Delay	Off to On On to Off
	24±10ms for ac 10±4ms for dc 24±10ms for ac 20±9ms for dc
On-state Current (minimum)	5.0mA
Off-state Current (maximum)	1.7mA
Off-state Voltage (maximum)	45V ac
Input Impedance	Refer to simplified schematic
Power Dissipation	4.4 Watts (max.), 0.4 Watts (min.)
Thermal Dissipation	15.0 BTU/hr (max.), 1.3 BTU/hr (min.)
Backplane Current	74mA
Isolation Voltage	Isolation meets or exceeds UL Standard 508, and CSA Standard C22.2 No. 142.
Environmental Conditions	
Operational Temperature	0° to 60°C (32° to 140°F)
Storage Temperature	-40° to 85°C (-40° to 185°F)
Relative Humidity	5 to 95% without condensation
Conductors	Wire Size Category
	14 gauge (2mm ²) stranded maximum 3/64 inch (1.2mm) insulation maximum 1 ¹
Keying	Between 4 and 6 Between 28 and 30
Field Wiring Arm	Catalog Number 1771-WD
Wiring Arm Screw Torque	7-9 inch-pounds
Agency Certification (when product or packaging is marked)	<ul style="list-style-type: none"> • CSA certified • CSA Class 1, Division 2, Groups A, B, C, D certified • UL listed • CE marked for all applicable directives
Installation Instructions	1771-2.19

¹ You use this conductor-category information for planning conductor routing as described in the system-level installation manual.

Status Indicators

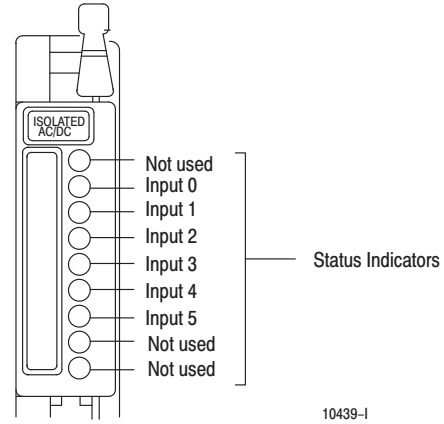

Sample Connection Diagram – Driving a 1771-ID Module with an Output Module

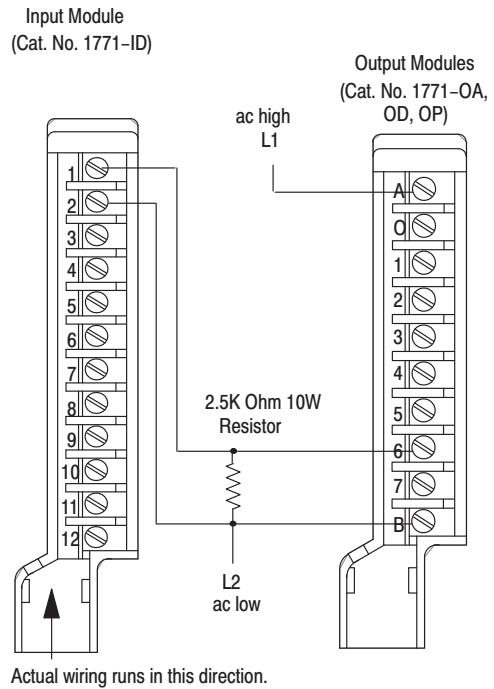

Isolated AC/DC Input Module (Cat. No. 1771-ID01)

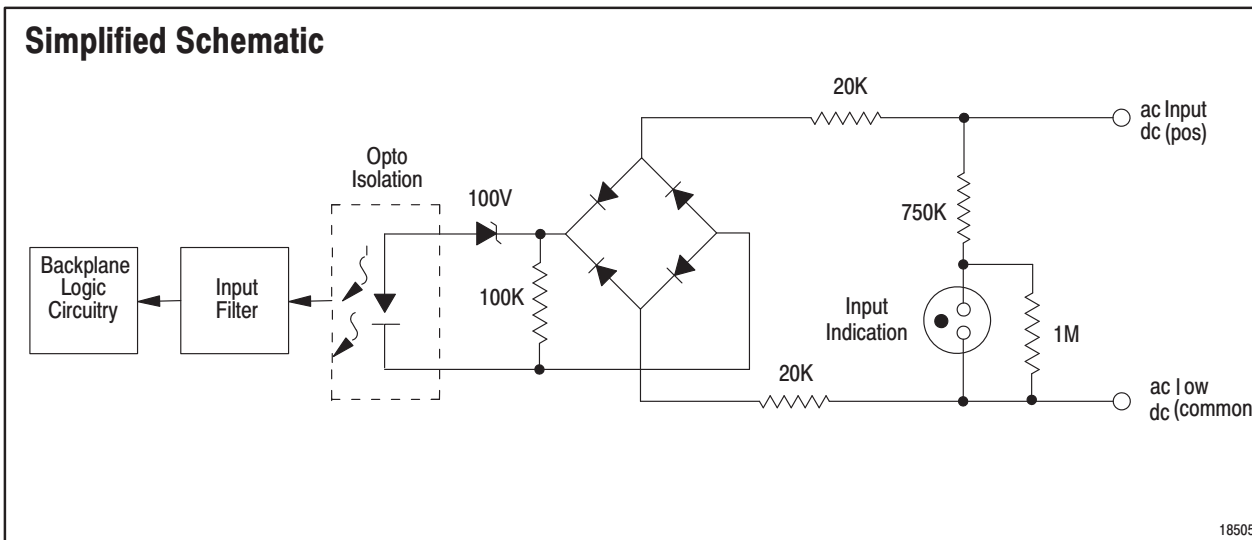

18505

Application Notes

Device Compatibility. This module is designed to operate with ac input devices such as limit switches, float switches, selector switches and pushbutton switches.

Connection to Output Module. You can use an ac (220/240V) output module (cat. no. 1771-OM) to directly drive terminals on an ac/dc (220/240V) input module (cat. no. 1771-ID01), but you must connect a 3.3K ohm 20W resistor or an electrocube snubber (part number RG-1676-32) between the output terminal and L2 (common). Use the same ac power source to power both modules to ensure proper phasing and prevent module damage.

Status Indicators. The front panel has 6 orange status indicators. Each status indicator is illuminated when its corresponding circuit has ac/dc voltage applied to it. The indicators are provided for system field side indication of individual inputs.

Inrush Current Considerations. The peak inrush current at turn-on can be calculated as follows:

$$\text{Peak inrush current} = (V_{PS} - 100)/40K \text{ ohms}$$

Where: V_{PS} = customer supply peak voltage

Connection Diagram

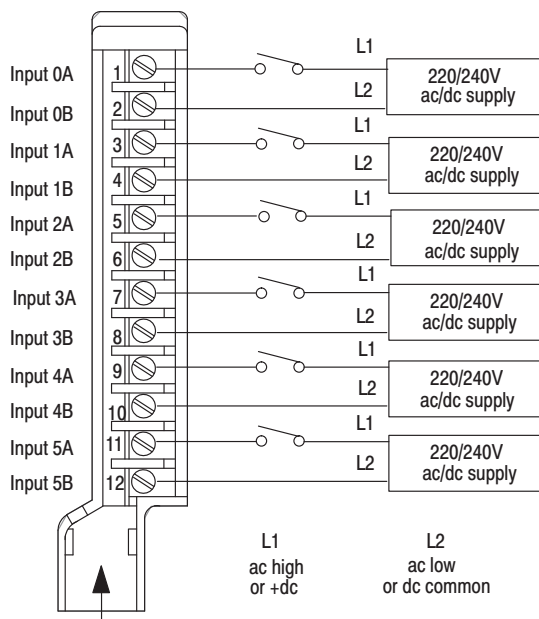

(Actual wiring runs in this direction.)

(See applicable codes and laws.)

11920-1

Isolated AC/DC Input Module (Cat. No. 1771-ID01)

Specifications (Cat. No. 1771-ID01)

Inputs per Module	6	
Module Location	1771 I/O chassis	
Nominal Input Voltage	220/240V ac @ 47 - 63Hz 240V dc	
Nominal Input Current	3.0mA @ 220V ac 50Hz 3.5mA @ 220V ac 60Hz 3.0mA @ 220V dc	
Input Voltage Range	184V ac to 276V ac; 184V dc to 276V dc	
Input Signal Delay	Off to On On to Off	20±10ms for ac 10±4ms for dc 20±10ms for ac 20±9ms for dc
On-state Current (minimum)	1.8mA	
On-state Voltage (minimum)	184V ac	
Off-state Current (maximum)	ac: 0.7mA; dc: 1.0mA	
Off-state Voltage (maximum)	102.09V ac; 144.4V dc	
Input Impedance	Refer to simplified schematic	
Power Dissipation	2.4 Watts (max.), 0.4 Watts (min.)	
Thermal Dissipation	8.2 BTU/hr (max.), 1.4 BTU/hr (min.)	
Backplane Current	74mA	
Isolation Voltage	Isolation meets or exceeds UL Standard 508, and CSA Standard C22.2 No. 142.	
Environmental Conditions		
Operational Temperature	0° to 60°C (32° to 140°F)	
Storage Temperature	-40° to 85°C (-40° to 185°F)	
Relative Humidity	5 to 95% without condensation	
Conductors	Wire Size Category	14 gauge (2mm ²) stranded maximum 3/64 inch (1.2mm) insulation maximum 1 ¹
Keying		Between 4 and 6 Between 14 and 16 Between 28 and 30
Field Wiring Arm	Catalog Number 1771-WD	
Wiring Arm Screw Torque	7-9 inch-pounds	
Agency Certification (when product or packaging is marked)		<ul style="list-style-type: none"> • CSA certified • CSA Class I, Division 2, Groups A, B, C, D certified • UL listed • CE marked for all applicable directives
Installation Instructions	1771-2.102	

¹ You use this conductor-category information for planning conductor routing as described in the system-level installation manual.

Status Indicators

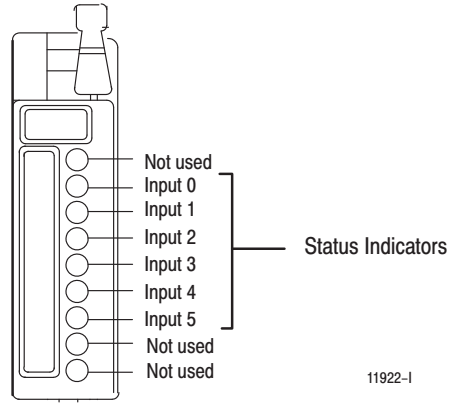

Sample Connection Diagram - Driving a 1771-ID01 Module with a 1771-OM Module

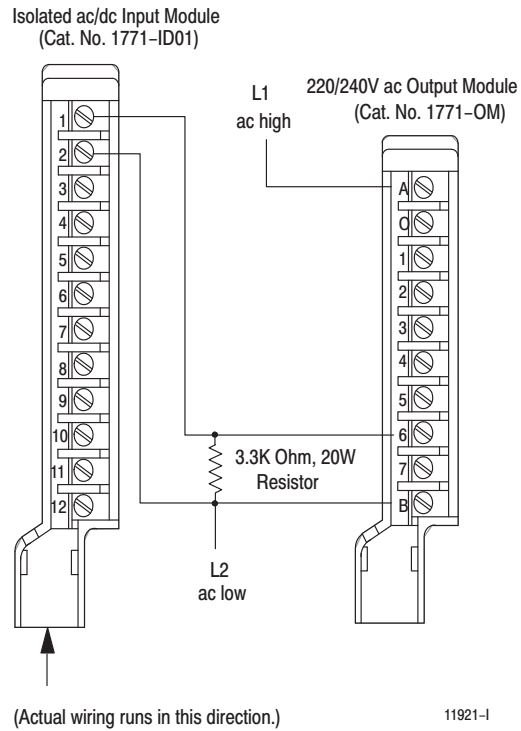

Isolated AC/DC Input Module (Cat. No 1771-ID16)

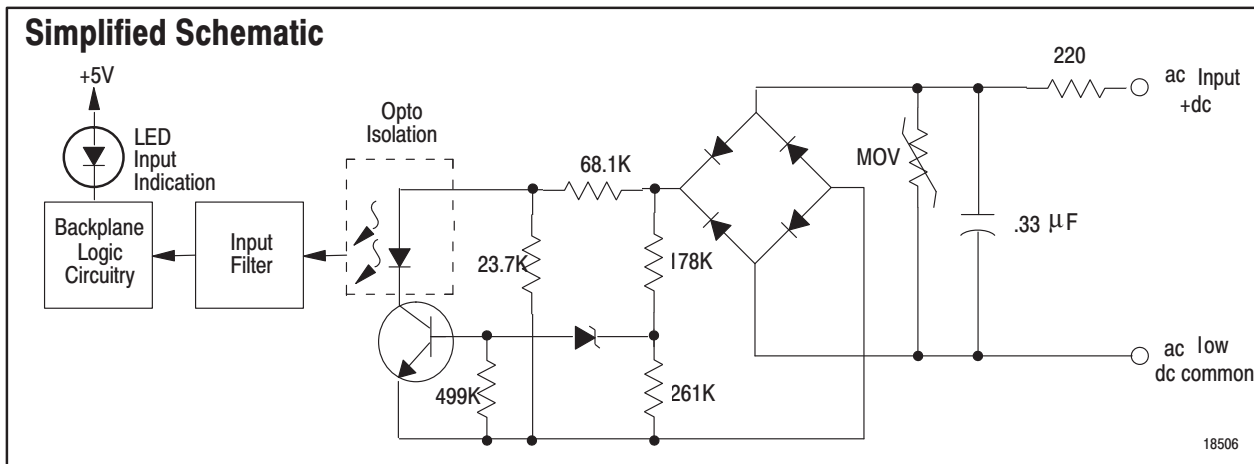

Application Notes

Device Compatibility. This module is designed to operate with limit switches, float switches, selector switches and pushbutton switches.

Product Compatibility. This module must be used with a 1771-A1B thru -A4B or later I/O chassis.

Connection to Output Modules. You can use an ac output module (Cat. No. 1771-OA, 1771-OD or 1771-OP) to directly drive terminals on an ac (120V) input module (Cat. No. 1771-ID16), but you must connect a 2.5K ohm, 10W resistor between the output terminal an L2 (common). You can use an ac (120V) output module (Cat. No. 1771-OD16 or -OAD) to drive the 1771-ID16 module without using a resistor.

Setting the Filter Time Jumpers. Use the figure below to set the filter time jumpers to fast or normal.

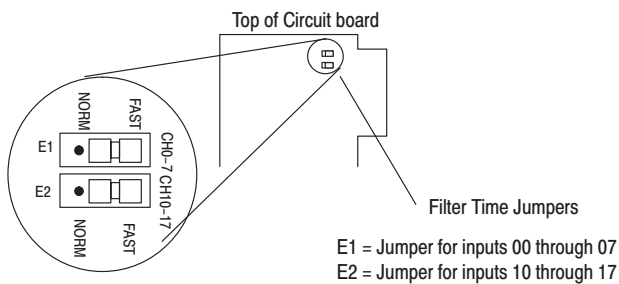

Status Indicators. The front panel has one green module active indicator and 16 red status indicators. The 16 status indicators will light when the field load has been applied to the field wiring arm of the module. The active indicator will light when the module has successfully started up and initialized.

Inrush Current Considerations. Due to capacitive impedance input, there is an initial current associated with the 1771-ID16. The peak inrush current at turn-on can be calculated as follows:

Peak Inrush Current = $(V_{PS})/220$ ohms
 where: V_{PS} = customer supply peak voltage.

Connection Diagram

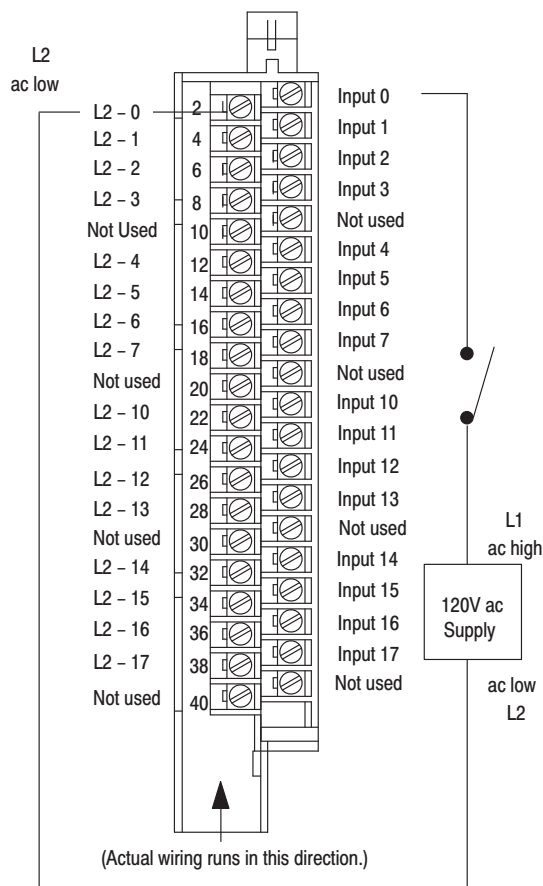

Isolated AC/DC Input Module (Cat. No 1771-ID16)

Specifications (Cat. No. 1771-ID16)

Inputs per Module	16
Module Location	1771-A1B thru -A4B or later I/O chassis 1771-AM1, -AM2 Chassis
Input Voltage Range	74-138V ac, 47-63Hz; 105-138V dc
Nominal Input Voltage	120V ac/dc
Nominal Input Current	120V ac: 12.4mA @ 50Hz; 14.9mA @ 60Hz 120V dc: 2.5mA
On-state Voltage (minimum)	74V ac; 105V dc
On-state Current (minimum)	6.0mA @ 74V ac, 47-63Hz 2.0mA @ 105V dc
Off-state Voltage (maximum)	45V ac; 66V dc
Off-state Current (minimum)	4mA @ 45V ac, 47-63Hz; 0.8mA @ 63V dc
Input Signal Delay	Off to On On to Off 1.0ms for ac; 1.0ms for dc Selectable: 9ms or 18.0ms for ac; 9ms for dc
Input Impedance (minimum)	ac: 9.3K ohms @ 47Hz; 6.9K ohms @ 63Hz dc: 75K ohms off; 48K ohms on
Power Dissipation	7.0 Watts (max.), 0.3 Watts (min.)
Thermal Dissipation	23.8 BTU/hr (max.), 1.0 BTU/hr (min.)
Backplane Current	75mA maximum
Isolation Voltage	Isolation meets or exceeds UL Standard 508, and CSA Standard C22.2 No. 142.
Maximum Cable Length	1000ft (304.8m)
Environmental Conditions	
Operational Temperature	0° to 60°C (32° to 140°F)
Storage Temperature	-40° to 85°C (-40° to 185°F)
Relative Humidity	5 to 95% (without condensation)
Conductors Wire Size	14 gauge (2mm ²) stranded maximum ² 3/64 inch (1.2mm) insulation maximum
Category	1 ¹
Keying	Between 22 and 24 Between 26 and 28
Field Wiring Arm	Catalog Number 1771-WN
Wiring Arm Screw Torque	7-9 inch-pounds
Agency Certification (when product or packaging is marked)	<ul style="list-style-type: none"> • CSA certified • CSA Class I, Division 2, Groups A, B, C, D certified • UL listed • CE marked for all applicable directives
Installation Instructions	1771-2.189

¹ You use this conductor-category information for planning conductor routing as described in the system-level installation manual.
² 14 gauge wire connected to all terminals may not allow the field wiring arm cover to close. A smaller gauge wire may be required.

Status Indicators

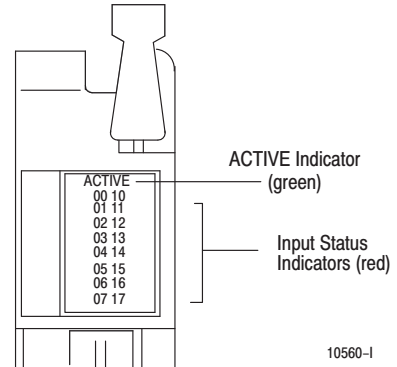

Sample Connection Diagram – Driving a 1771-ID16 Module with a 1771-OD16 Module

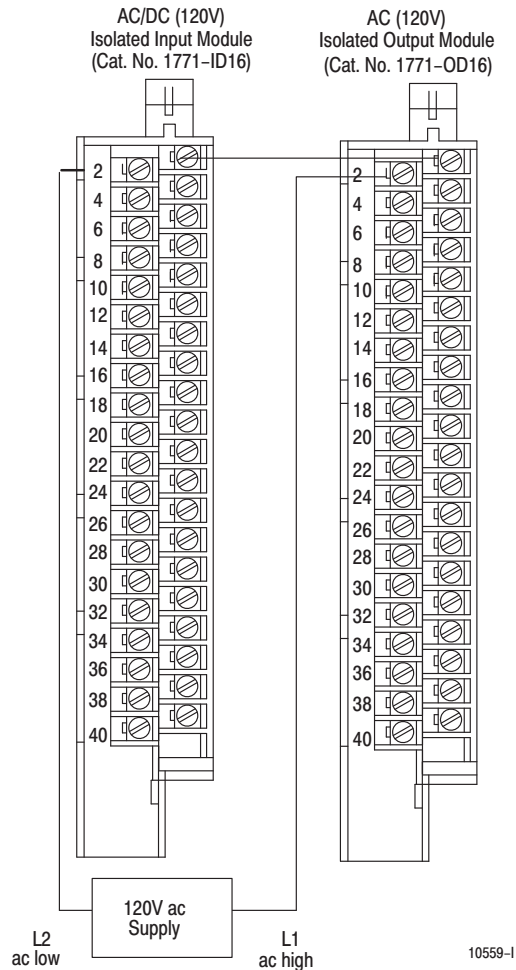

AC/DC Input Module (Cat. No. 1771-IM)

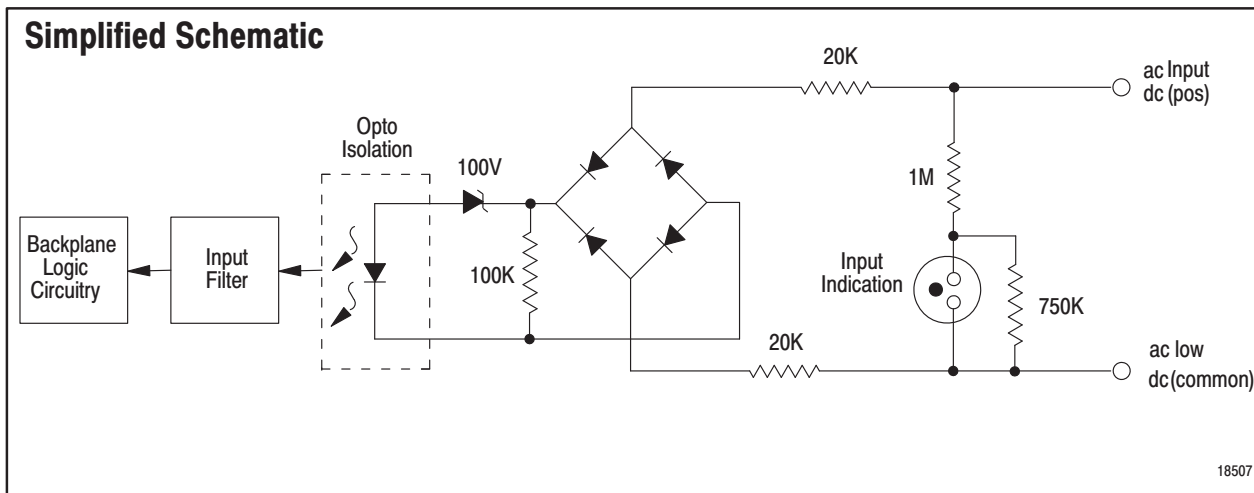

18507

Application Notes

Device Compatibility. This module is designed to operate with ac limit switches, selector switches, float switches and pushbutton switches.

Connection to Output Module. You can use an ac (220/240V) output module (cat. no.1771-OM, -OMD, -OR) to directly drive terminals on an ac/dc (220/240V) input module (cat. no.1771-IM), but you must connect a 3.3K ohm, 20W resistor between the output terminal and L2 (common). As an alternative you can use an electrocube snubber (part number RG-1676-32). Use the same ac power source to power both modules to ensure proper phasing and to prevent module damage.

Status Indicators. The front panel has 8 status indicators. Each indicator is illuminated when its corresponding input circuit has ac/dc voltage applied. The indicators are provided for field side indication of individual inputs.

Inrush Current Considerations. The peak inrush current at turn-on can be calculated as follows:

$$\text{Peak inrush current} = (V_{PS} - 100)/40K \text{ ohms}$$

Where: V_{PS} = customer supply peak voltage

Connection Diagram

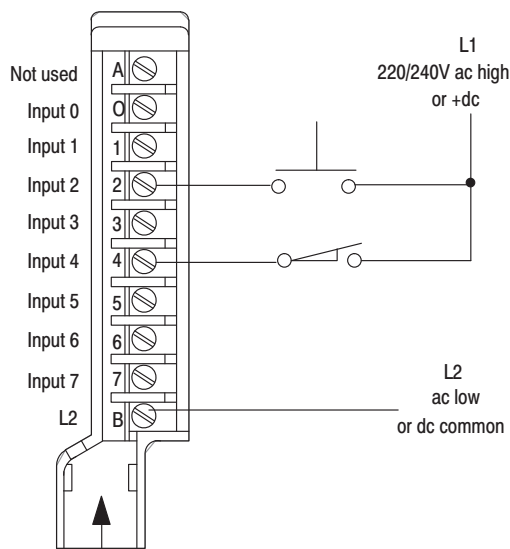

(Actual wiring runs in this direction.)

11836-1

AC/DC Input Module (Cat. No. 1771-IM)

Specifications (Cat. No. 1771-IM)	
Inputs per Module	8
Module Location	1771 I/O chassis
Nominal Input Voltage	220/240V ac @ 47 - 63Hz 240V dc
Nominal Input Current	3.0mA @ 220V ac 50Hz 3.5mA @ 220V ac 60Hz 2.6mA @ 240V dc
On-state Current (minimum)	2.9mA
Off-state Current (maximum)	1.0mA
Off-state Voltage (maximum)	92V ac/114V ac
Input Voltage Range	184V ac to 276V ac on-state 184V dc to 276V dc on-state
Input Impedance	Refer to simplified schematic
Input Signal Delay	Off to On On to Off
	20±6ms for ac 10±4ms for dc 20±6ms for ac 20±9ms for dc
Power Dissipation	2.4 Watts (max.); 0.4 Watts (min.)
Thermal Dissipation	10.9 BTU/hr (max.); 3.2 BTU/hr (min.)
Backplane Current	75mA
Isolation Voltage	Isolation meets or exceeds UL Standard 508, and CSA Standard C22.2 No. 142.
Environmental Conditions	
Operational Temperature	0° to 60°C (32° to 140°F)
Storage Temperature	-40° to 85°C (-40° to 185°F)
Relative Humidity	5 to 95% without condensation
Conductors	Wire Size Category
	14 gauge (2mm ²) stranded maximum 3/64 inch (1.2mm) insulation maximum 1 ¹
Keying	Between 6 and 8 Between 30 and 32
Field Wiring Arm	Catalog Number 1771-WA
Wiring Arm Screw Torque	7-9 inch-pounds
Agency Certification (when product or packaging is marked)	<ul style="list-style-type: none"> • CSA certified • CSA Class I, Division 2, Groups A, B, C, D certified • UL listed • CE marked for all applicable directives
Installation Instructions	1771-2.20

¹ You use this conductor-category information for planning conductor routing as described in the system-level installation manual.

Status Indicators

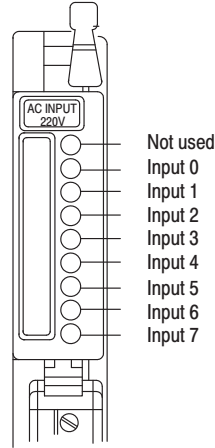

11838-1

Sample Connection Diagram – Driving a 1771-IM Module with a 1771-OM Module

AC (220/240V) Output Module (Cat. No. 1771-OM) AC/DC (220/240V) Input Module (Cat. No. 1771-IM)

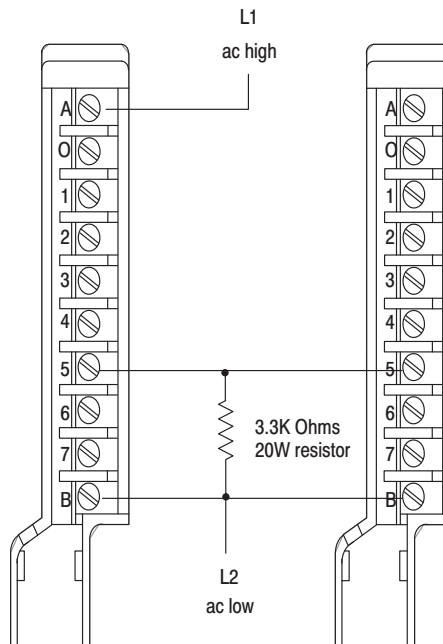

11837-1

AC/DC Input Module (Cat. No. 1771-IMD Series B)

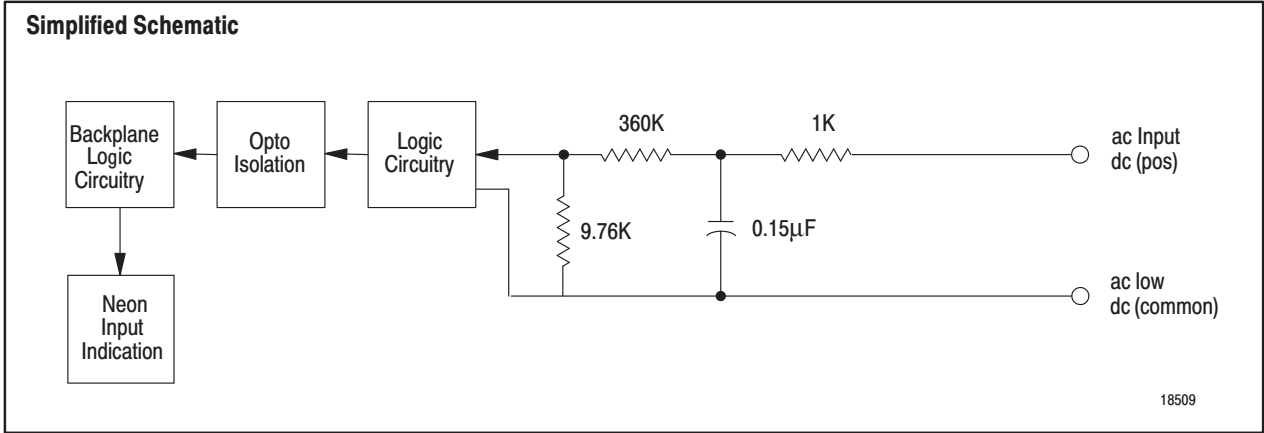

Application Notes

Product Compatibility. This module must be used with a 1771-A1B thru -A4B or later I/O chassis.

Connection to Output Modules. You can use an ac (220V) output module (cat. no. 1771-OMD) to directly drive terminals on an ac (220V) input module (cat. no. 1771-IMD). You can also use a 1771-OM or -OR output module to drive an ac (220V) input module (cat. no. 1771-IMD) but you must connect a 10K ohm 10W resistor between the output terminal and L2 (common). **Use the same ac power source to power both modules to ensure proper phasing and prevent module damage.**

Setting the Fault Mode. Use the jumper below to set the fault mode to last state (LS) or reset.

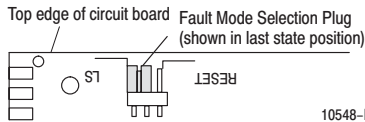

Status Indicators. The front panel has one green, module-active indicator, and 16 red status indicators. The 1771-IMD performs diagnostics in a handshaking mode when first powered up. Upon successful completion of the diagnostics, the green module-active indicator is illuminated. Each status indicator is provided for system logic side indication of individual inputs. When a status indicator is illuminated, voltage is present on the terminal.

Inrush Current Considerations. Due to capacitive impedance input, there is an initial current associated with the 1771-IMD. The peak inrush current at turn-on can be calculated as follows:

Peak Inrush Current = $V_{PS}/1K$ ohms
 where: V_{PS} = customer supply peak voltage.

Connection Diagram

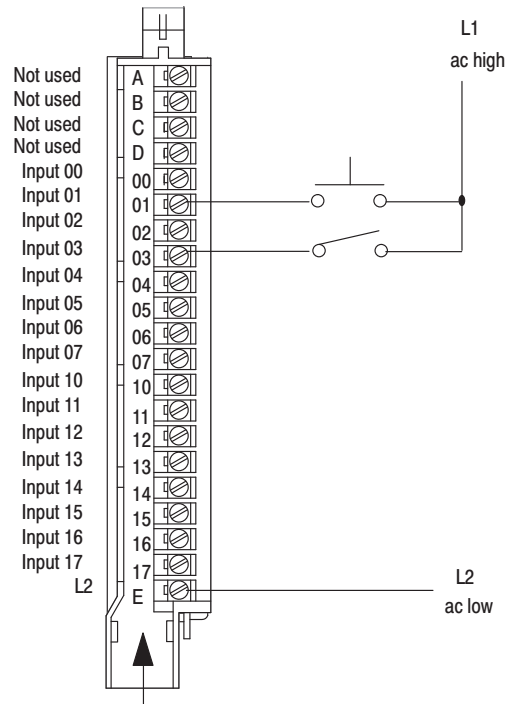

(Actual wiring runs in this direction.)

10549-1

AC/DC Input Module (Cat. No. 1771-IMD Series B)

Specifications (Cat. No. 1771-IMD/B)

Inputs per Module	16	
Module Location	1771-A1B thru -A4B or later I/O Chassis 1771-AM1, -AM2 I/O chassis	
Nominal Input Voltage	220V ac @ 50/60Hz; 220V dc	
Nominal Input Current	9.9mA @ 220V ac 50Hz 10.4mA @ 220V ac 60Hz 0.6mA @ 220V dc	
On-state Voltage Range	184V to 250V ac 166V to 230V dc	
On-state Current (minimum)	8.7mA at 184V ac, 50Hz 0.43mA at 166V dc	
Off-state Voltage (maximum)	92V ac or dc	
Off-state Current (maximum)	3mA at 92V ac 0.25mA at 92V dc	
Input Impedance	0.15µF capacitor (21.2K impedance at 50Hz) in parallel with a 370K resistor; in series with 1K ohm	
Input Signal Delay	Off to On On to Off	15±8ms for ac and dc 172±56ms for ac and dc
Power Dissipation	5.8 Watts (max.), 1.3 Watts (min.)	
Thermal Dissipation	19.8 BTU/hr (max.), 4.5 BTU/hr (min.)	
Backplane Current	250mA @ 5V dc ±5%	
Isolation Voltage	Isolation meets or exceeds UL Standard 508, and CSA Standard C22.2 No. 142.	
Environmental Conditions		
Operational Temperature	0° to 60°C (32° to 140°F)	
Storage Temperature	-40° to 85°C (-40° to 185°F)	
Relative Humidity	5 to 95% without condensation	
Conductors	Wire Size	14 gauge (2mm ²) stranded maximum
Category		3/64 inch (1.2mm) insulation maximum
		1 ¹
Keying		Between 2 and 4 Between 12 and 14
Field Wiring Arm		Catalog Number 1771-WH
Wiring Arm Screw Torque		7-9 inch-pounds
Agency Certification (when product or packaging is marked)		<ul style="list-style-type: none"> • CSA certified • CSA Class I, Division 2, Groups A, B, C, D certified • UL listed • CE marked for all applicable directives
Installation Instructions		1771-5.27

¹ You use this conductor-category information for planning conductor routing as described in the system-level installation manual.

Status Indicators

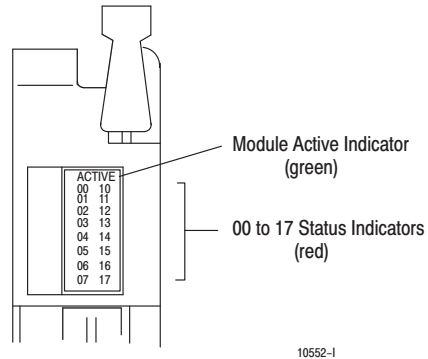

10552-1

Sample Connection Diagram – Driving a 1771-IMD Module with a 1771-OMD Module

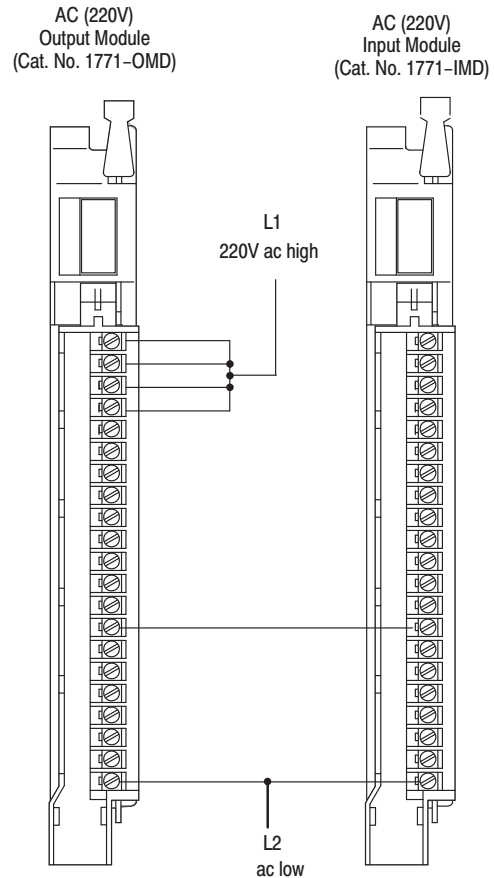

10550-1

AC Input Module (Cat. No. 1771-IN)

Simplified Schematic

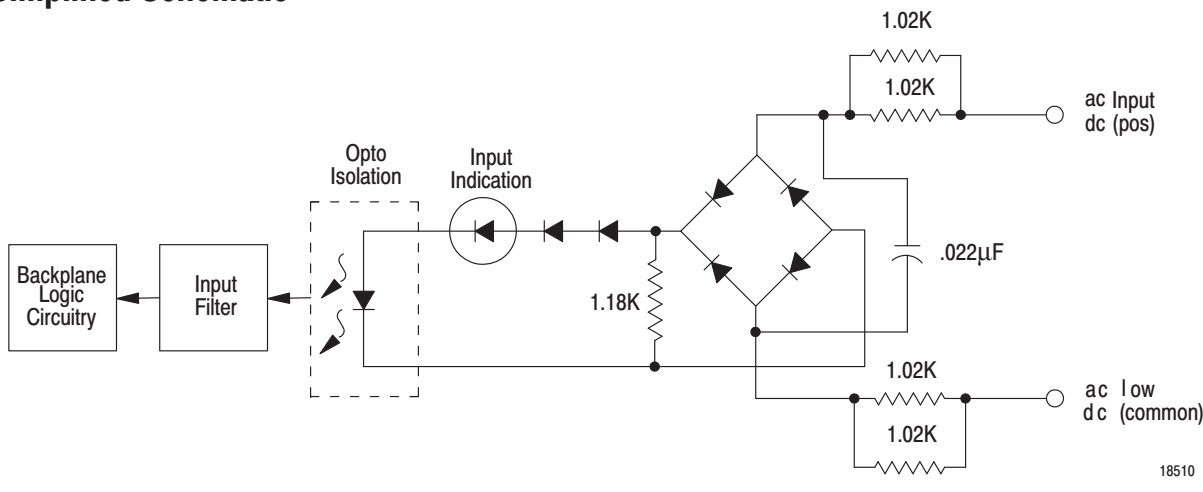

Application Notes

Device Compatibility. This module is designed to operate with ac proximity switches and other input devices with an off-state leakage current less than 2.8mA peak.

Connection to Output Module. You can use an ac (24V) output module (cat. no. 1771-ON) to directly drive terminals on an ac/dc (24V) input module (cat. no. 1771-IN), but you must connect a 250 ohm, 5W resistor between the output terminal and L2 (common). **Use the same ac power source to power both modules to ensure proper phasing and to prevent module damage.**

Status Indicators. The front panel has eight red status indicators. Each status indicator is provided for field side indication of individual inputs. An indicator lights when the corresponding input circuit has ac power applied to it.

Inrush Current Considerations. Due to capacitive impedance input, there is an initial current associated with the 1771-IN. The peak inrush current at turn-on can be calculated as follows:

$$\text{Peak Inrush Current} = V_{PS} / 1.02K \text{ ohms}$$

where: V_{PS} = customer supply peak voltage.

Connection Diagram

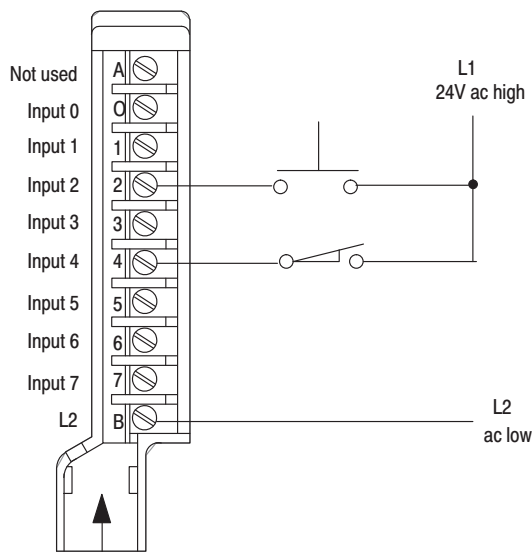

(Actual wiring runs in this direction.)

11902-1

AC Input Module (Cat. No. 1771-IN)

Specifications (Cat. No. 1771-IN)		
Inputs per Module	8	
Module Location	1771 I/O chassis	
Nominal Input Voltage	24V ac @ 47-63Hz	
Nominal Input Current	15.5mA @ 24V ac 50Hz 18.0mA @ 24V ac 60Hz	
On-state Current (minimum)	7.4 mA	
On-state Voltage Range	12 to 28V ac	
Off-state Voltage (maximum)	10.5V ac	
Off-state Current (maximum)	2.8mA ac	
Input Impedance	Refer to simplified schematic	
Input Signal Delay	Off to On On to Off	18±10ms 18±10ms
Power Dissipation	3.1 Watts (max.), 0.4 Watts (min.)	
Thermal Dissipation	10.6 BTU/hr (max.), 1.4 BTU/hr (min.)	
Backplane Current	80mA	
Isolation Voltage	Isolation meets or exceeds UL Standard 508, and CSA Standard C22.2 No. 142.	
Environmental Conditions		
Operational Temperature	0° to 60°C (32° to 140°F)	
Storage Temperature	-40° to 85°C (-40° to 185°F)	
Relative Humidity	5 to 95% without condensation	
Conductors	Wire Size	14 gauge (2mm ²) stranded maximum 3/64 inch (1.2mm) insulation maximum 2 ¹
	Category	
Keying	Between 4 and 6 Between 10 and 12	
Field Wiring Arm	Catalog Number 1771-WA	
Wiring Arm Screw Torque	7-9 inch pounds	
Agency Certification (when product or packaging is marked)	<ul style="list-style-type: none"> • CSA certified • CSA Class I, Division 2, Groups A, B, C, D certified • UL listed • CE marked for all applicable directives 	
Installation Instructions	1771-2.41	

¹ You use this conductor-category information for planning conductor routing as described in the system-level installation manual.

Status Indicators

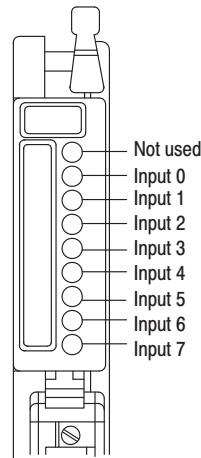

11904-I

Sample Connection Diagram – Driving a 1771-IN Module with a 1771-ON Module

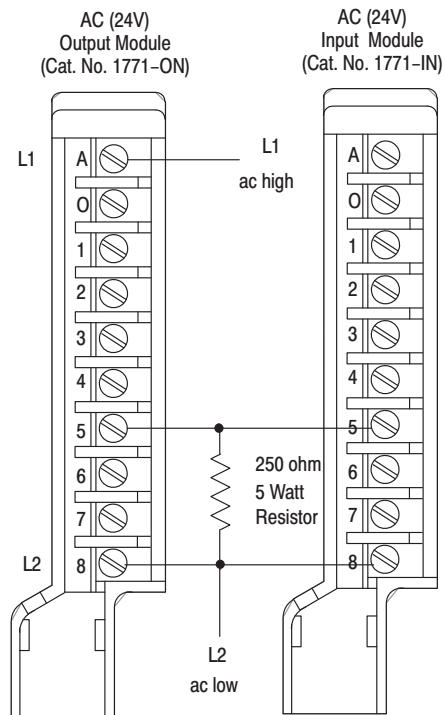

11903-I

AC/DC Input Module (Cat. No. 1771-IND Series B)

Simplified Schematic

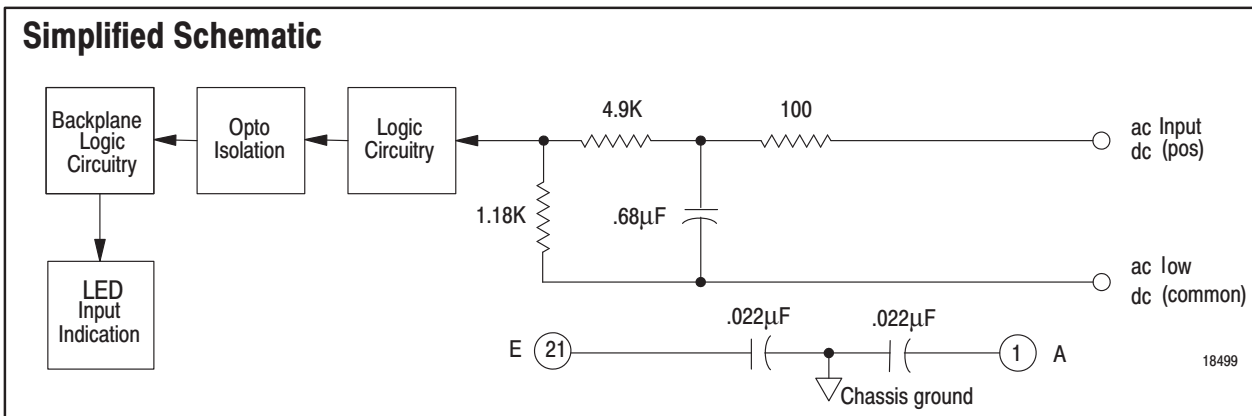

Application Notes

Product Compatibility. This module must be used with a 1771-A1B thru -A4B or later I/O chassis.

Connection to Output Modules. You can use an ac (24V) output module (cat. no. 1771-OND) to directly drive terminals on an ac (24V) input module (cat. no. 1771-IND). You can also use an output module (cat. no. 1771-ON) to drive an ac input module (cat. no. 1771-IND), but you must connect a 470 ohm, 3W resistor between the output terminal and L2 (common). Use the same ac power source to power both modules to ensure proper phasing and prevent module damage.

Setting the Fault Mode. Use the jumper below to set the fault mode to last state (LS) or reset position.

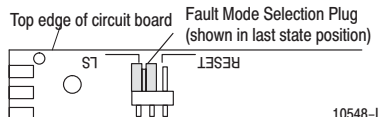

Status Indicators. The front panel has one green, module-active indicator, and 16 red status indicators. The 1771-IND performs diagnostics in a handshaking mode when first powered up. Upon successful completion of the diagnostics, the module-active indicator is illuminated. The status indicators are provided for system logic side indication of individual inputs. Each indicator is illuminated when its corresponding circuit has ac/dc voltage applied to it.

Inrush Current Considerations. Due to capacitive impedance input, there is an initial current associated with the 1771-IND. The peak inrush current at turn-on can be calculated as follows:

Peak Inrush Current = $V_{PS}/100$ ohms
 where: V_{PS} = customer supply peak voltage.

Connection Diagram

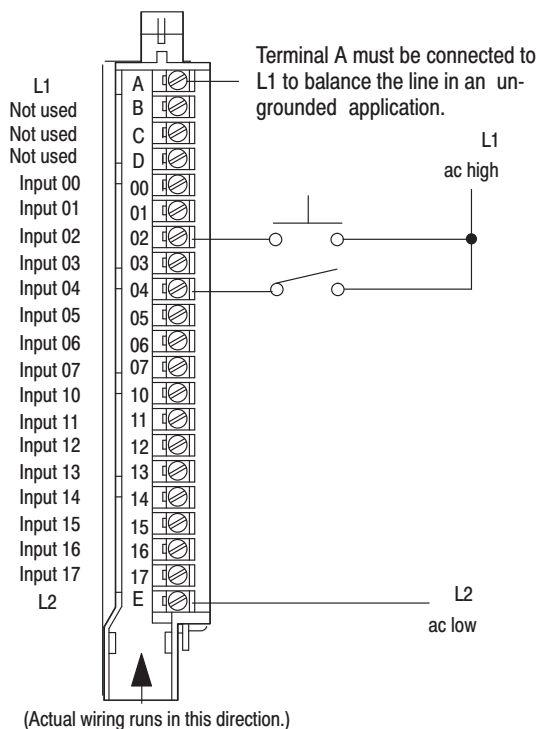

10426-I

AC/DC Input Module (Cat. No. 1771-IND Series B)**Specifications (Cat. No. 1771-IND/B)**

Inputs per Module	16	
Module Location	1771-A1B thru -A4B or later I/O chassis -AM1, -AM2 I/O chassis	
Nominal Input Voltage	24V ac @ 50/60Hz 24V dc	
Nominal Input Current	6.3mA @ 24V ac 50Hz 7.2mA @ 24V ac 60Hz 3.8mA at 24V dc	
On-state Voltage Range	16V to 30V ac 9V to 30V dc	
On-state Current (minimum)	3.0mA at 10V ac, 60Hz 1.4mA at 9V dc	
Off-state Voltage (maximum)	5V ac at 50/60Hz; 3.7V dc	
Off-state Current (maximum)	1.5mA at 5V ac, 60Hz 0.6mA at 5V dc	
Input Impedance	0.68 μ F in parallel with 6.28K (3.9K ohms at 60Hz); in series with 100 ohms	
Peak Inrush Current	$V_{ps}/100$ ohms, where V_{ps} = customer supply peak voltage	
Input Signal Delay	Off to On	35ms \pm 10ms for 24V ac 10ms for 24V dc
	On to Off	45ms \pm 15ms for 24V ac 50ms for 24V dc
Power Dissipation	8.3 Watts (max.), 1.3 Watts (min.)	
Thermal Dissipation	28.4 BTU/hr (max.), 4.4 BTU/hr (min.)	
Backplane Current	250mA @ 5V dc \pm 5%	
Isolation Voltage	Isolation meets or exceeds UL Standard 508, and CSA Standard C22.2 No. 142.	
Environmental Conditions		
Operational Temperature	0 $^{\circ}$ to 60 $^{\circ}$ C (32 $^{\circ}$ to 140 $^{\circ}$ F)	
Storage Temperature	-40 $^{\circ}$ to 85 $^{\circ}$ C (-40 $^{\circ}$ to 185 $^{\circ}$ F)	
Relative Humidity	5 to 95% (without condensation)	
Conductors	Wire Size	14 gauge (2mm 2) stranded maximum 3/64 inch (1.2mm) insulation maximum
	Category	1 ¹
Keying	Between 20 and 22 Between 34 and 36	
Field Wiring Arm	Catalog Number 1771-WH	
Wiring Arm Screw Torque	7-9 inch-pounds	
Agency Certification (when product or packaging is marked)	<ul style="list-style-type: none"> • CSA certified • CSA Class I, Division 2, Groups A, B, C, D certified • UL listed • CE marked for all applicable directives 	
Installation Instructions	1771-2.96	

¹ You use this conductor-category information for planning conductor routing as described in the system-level installation manual.

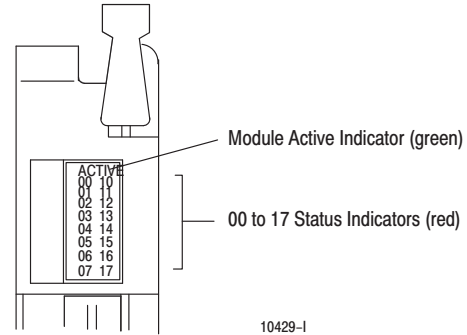
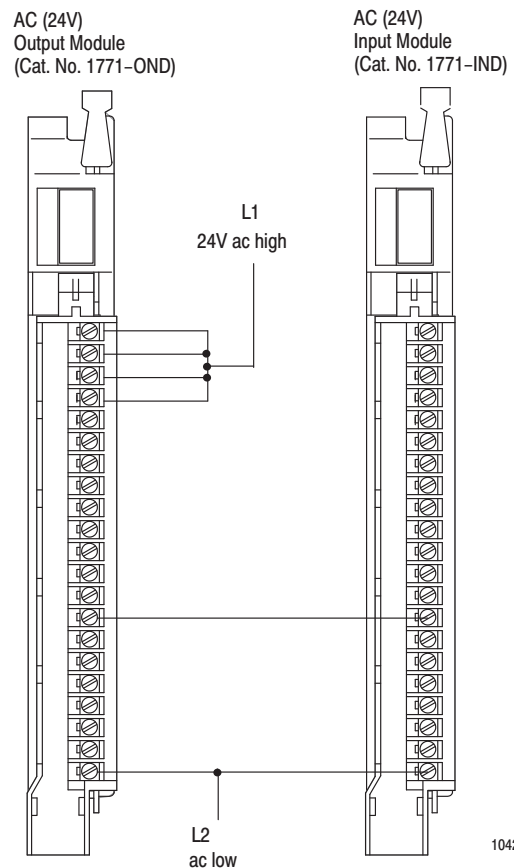
Status Indicators**Sample Connection Diagram – Driving a 1771-IND Module with a 1771-OND Module**

AC Output Module (Cat. No. 1771-OA Series B)

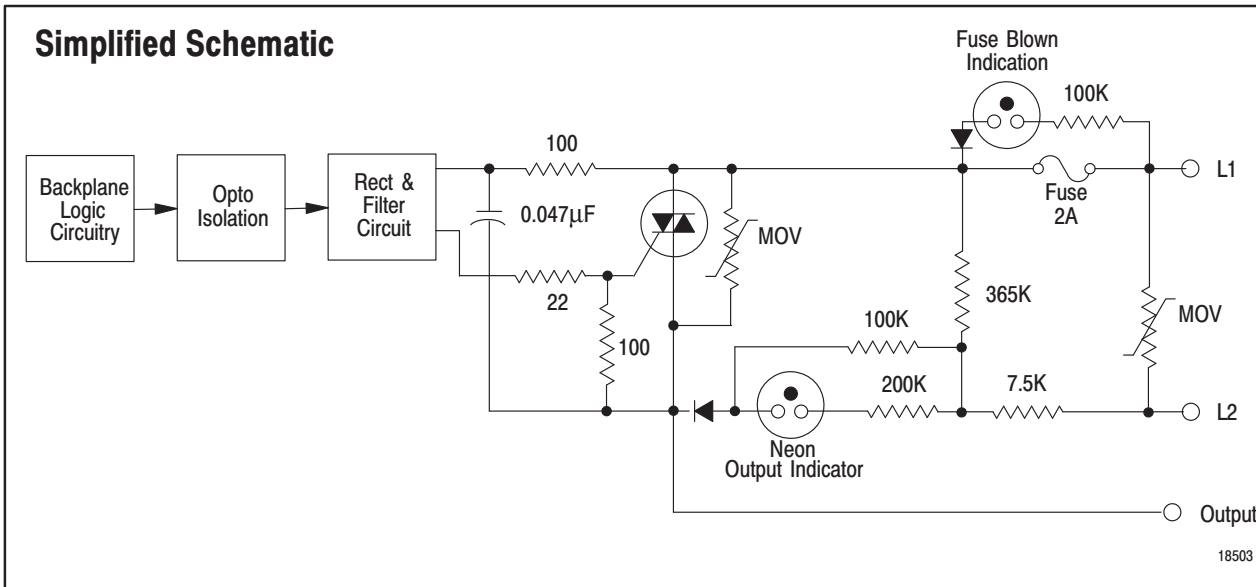

Application Notes

Device Compatibility. An output on the 1771-OA module can drive an Allen-Bradley motor starter up to a size 4, provided its supply voltage does not drop below 92V ac.

Minimum/Maximum Load Current. The module needs a minimum load current of 50mA to stay on. If your device pulls less than 50mA the triac may not operate. The maximum load current the module can deliver is 1.5A per output, not to exceed 6A total per module.

Connection to Input Modules. You can use an output of the 1771-OA module to drive an input of a 120V ac input module (1771-IA, -IA2, -ID, and -IAD). However, you must connect a 2.5K ohm, 10W resistor between the output and L2 (ac low). As an alternative you can connect an electrocube snubber (part number RG-1676-1). Use the same ac power source to power both modules to ensure proper phasing and prevent module damage.

Status Indicators. The module has eight status indicators and a fuse-blown indicator. The status indicators show the ON/OFF condition of an individual output. When the indicator is illuminated, the corresponding output is energized. The fuse-blown indicator, normally OFF, is illuminated when you blow a fuse. The indicators are provided for field side indication of individual outputs.

Connection Diagram

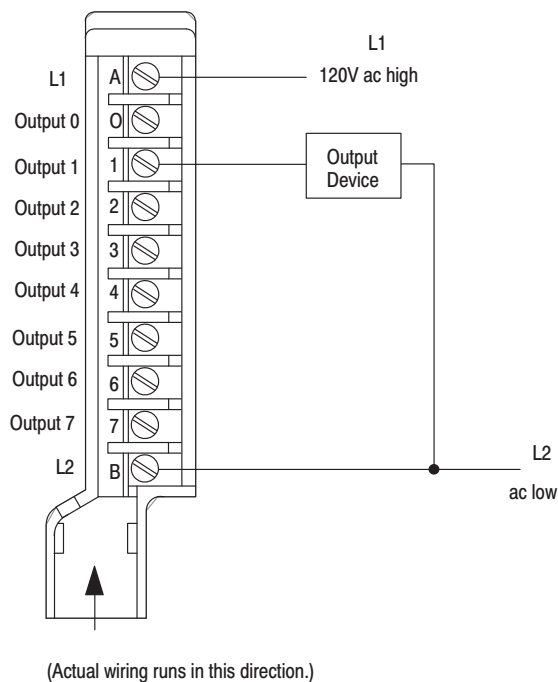

AC Output Module (Cat. No. 1771-OA Series B)

Specifications (Cat. No. 1771-OA/B)

Outputs per Module	8	
Module Location	1771 I/O chassis	
Output Voltage Range	92 to 138V ac @ 47 – 63Hz	
Output Current Rating	1.5A per output — not to exceed 6A per module	
Surge Current (maximum)	4A per output for 8.3ms at 120V ac, repeatable every 1 second	
Load Current (minimum)	50mA per output @ 120V ac, 60Hz	
On-State Voltage Drop	2V at 100mA	
Off-State Leakage Current (max.)	5mA per output @ 120V ac	
Signal Delay	Off to On On to Off	1.0ms 8.3ms @ 60Hz
Power Dissipation	10.7 Watts, 2V (max.), 1.1 Watts (min.)	
Thermal Dissipation	36.6 BTU/hr (max.), 3.4 BTU/hr (min.)	
Backplane Current	210mA @ 5V dc ±5%	
Isolation Voltage	Isolation meets or exceeds UL Standard 508, and CSA Standard C22.2 No. 142.	
Environmental Conditions		
Operational Temperature	0° to 60°C (32° to 140°F)	
Storage Temperature	-40° to 85°C (-40° to 185°F)	
Relative Humidity	5 to 95% (without condensation)	
Conductors	Wire Size	14 gauge (2mm ²) stranded maximum 3/64 inch (1.2mm) insulation maximum
	Category	1 ¹
Keying	Between 4 and 6 Between 12 and 14	
Fuse	2A, 250V Buss AGC-2 fuse Littlefuse Part No. 312002	
Field Wiring Arm	Catalog Number 1771-WA	
Wiring Arm Screw Torque	7-9 inch pounds	
Agency Certification (when product or packaging is marked)	<ul style="list-style-type: none"> • CSA certified • CSA Class I, Division 2, Groups A, B, C, D certified • UL listed • CE marked for all applicable directives 	
Installation Instructions	1771-2.5	

¹ You use this conductor-category information for planning conductor routing as described in the system-level installation manual.

Status Indicators

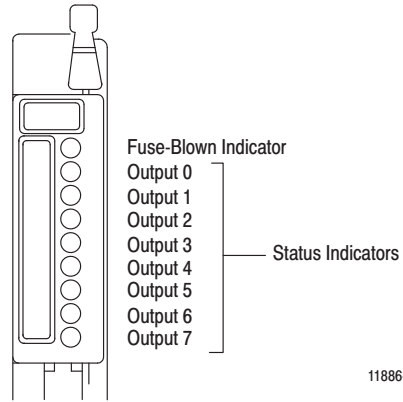

Sample Connection Diagram – Driving a 1771-IAD Module with a 1771-OA Module

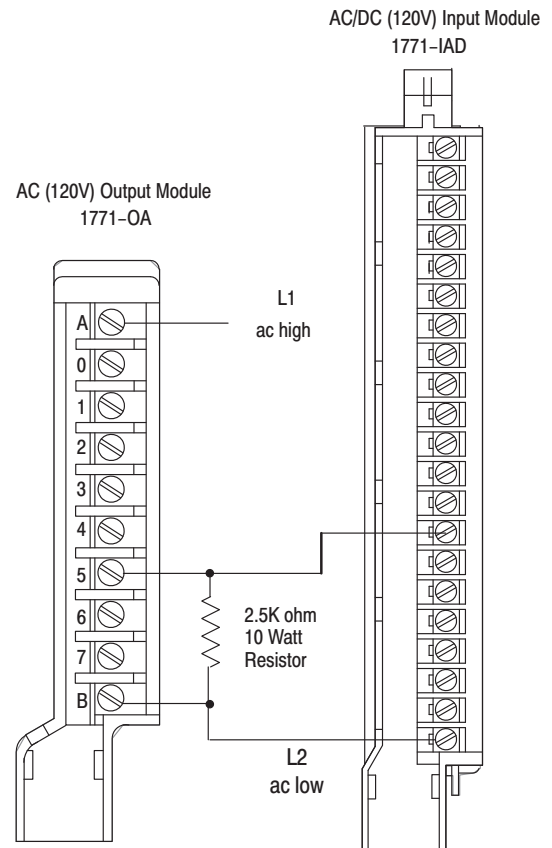

AC Output Module (Cat. No. 1771-OAD Series C)

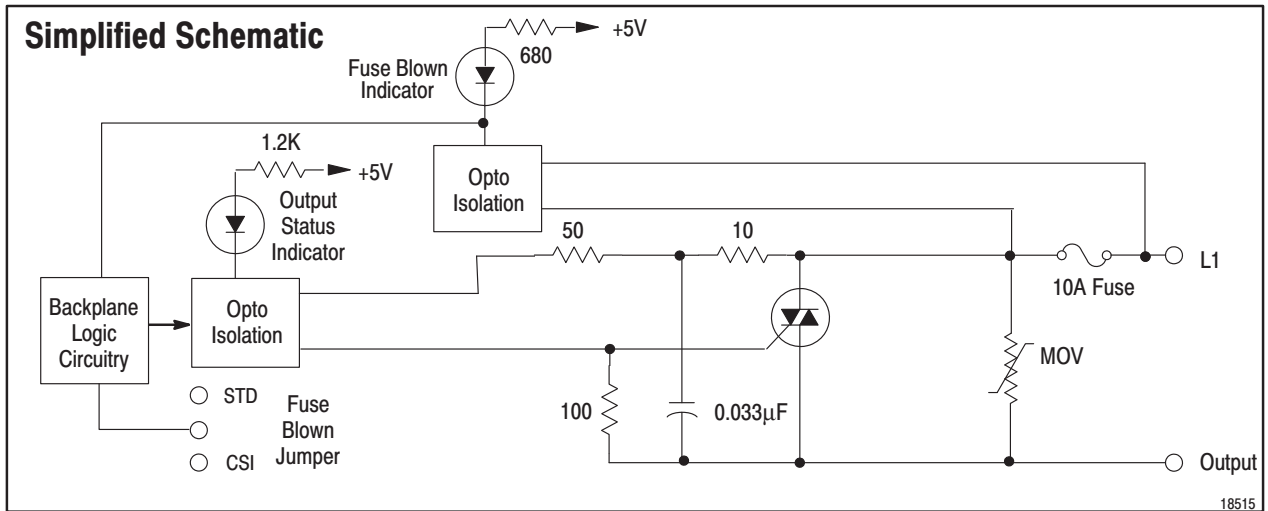

Application Notes

Product Compatibility. This module must be used with a 1771-A1B thru -A4B or later I/O chassis. An output from this module can drive an Allen-Bradley size 5 motor starter provided its supply voltage does not drop below 92V ac.

Connection to Wiring Arm. You need four ac (L1) connections on the wiring arm to accommodate the total required surge rating on the module without overstressing any single connection on the field wiring arm. Connect all ac (L1) connections to the copper four-position jumper (part number 976328-01) . The jumper is included on the wiring arm supplied with the 1771-OAD module.

Connection to Input Modules. This module can directly drive terminals on ac/dc input modules (cat. nos. 1771-IAD, -IND). It can also drive ac/dc input modules (cat. no. 1771-IA or -ID) but you must connect a 2500 ohm 10W resistor between the outputs and L2 (common). As an alternative you can use an electrocube snubber (part number RG-1676-1). **Use the same power source to ensure proper phasing and prevent module damage.**

Setting the Fuse-blown Mode Jumper. Set the jumper to STD for display of a fuse-blown condition on the indicator only. Set the jumper to CSI to display a fuse-blown condition on the indicator, and to set all 16 bits in the input image table for monitoring fuse-blown status in the user program. **NOTE: Do not set the jumper to CSI if using the module in a complementary mode.**

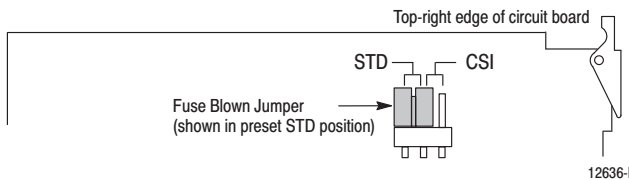

Status Indicators. The front panel has one green, module-active indicator, 16 red status indicators and one red fuse-blown indicator. In STD mode, the module-active indicator lights when the module is powered and the processor is in RUN mode. In CSI mode, the module-active indicator lights when the 5V dc backplane current has stabilized.

The module-active indicator must be on to properly interpret the status indicators. The status indicators provide system logic side indication of individual outputs. They indicate the state to which the triac is commanded by the processor, and are powered by circuitry within the module. The indicators turn on and off as commanded by the processor. They do not indicate the presence or absence of ac power at an output terminal.

Connection Diagram

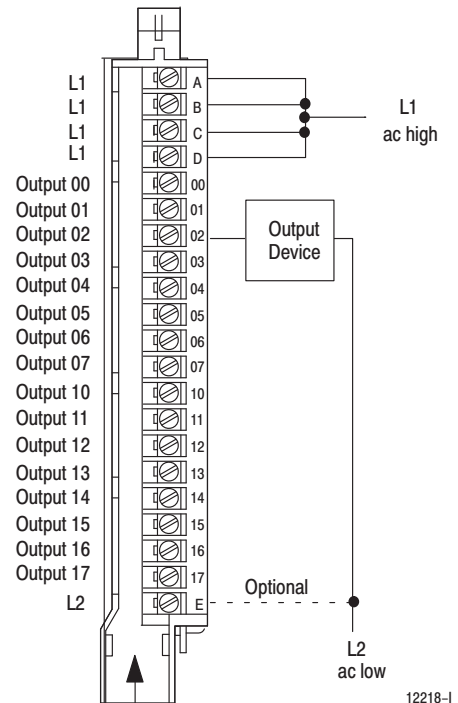

(Actual wiring runs in this direction.)

AC Output Module (Cat. No. 1771-OAD Series C)

Specifications (Cat. No. 1771-OAD Series C)

Outputs per Module	16	
Module Location	1771-A1B thru -A4B or later I/O chassis, 1771-AM1, -AM2 I/O chassis	
Output Voltage Range	10 to 138V ac @ 47 - 63Hz	
Output Current Rating	2A per output - not to exceed 8A per module	
Surge Current (maximum)	25A per output for 100ms, repeatable every 1 second 25A per module for 100ms, repeatable every 1 second	
Load Current (minimum)	5mA per output	
On-State Voltage Drop (max.)	1.5V at load current < 50mA 5.8V at load current > 50mA	
Off-State Leakage Current (max.)	3.0mA per output @ 138V ac	
Signal Delay	Off to On On to Off	Zero crossing: 8.3ms @ 60Hz; 10.0ms @ 50Hz Zero crossing: 8.3ms @ 60Hz; 10.0ms @ 50Hz
Power Dissipation	13.0 Watts (max.), 1.5 Watts (min.)	
Thermal Dissipation	48.0 BTU/hr (max.), 5.13 BTU/hr (min.)	
Backplane Current	295mA	
Isolation Voltage	Isolation meets or exceeds UL Standard 508, and CSA Standard C22.2 No. 142.	
Environmental Conditions		
Operational Temperature	0° to 60°C (32° to 140°F)	
Storage Temperature	-40° to 85°C (-40° to 185°F)	
Relative Humidity	5 to 95% (without condensation)	
Conductors	Wire Size	14 gauge (2mm ²) stranded maximum 3/64 inch (1.2mm) insulation maximum
	Category	1 ¹
Keying	Between 10 and 12 Between 20 and 22	
Fuse	10A, 250V rectifier fuse (1/4 x 1-1/4 inch), Littelfuse PN 322010	
Field Wiring Arm	Standard Optional Fused	Catalog Number 1771-WH Cat. No. 1771-WHF
Wiring Arm Screw Torque	7-9 inch pounds	
Relay Compatibility	700-HC14A1 700-HC14A1-4 700-HT12AA1 700-HF32A1 700-HTM12RA1 700-HP32A1-4 700-HB32A1 100-A09 100-A30 100-A18	
Agency Certification (when product or packaging is marked)	<ul style="list-style-type: none"> • CSA certified • CSA Class I, Division 2, Groups A, B, C, D certified • UL listed • CE marked for all applicable directives 	
Installation Instructions	1771-5.24	

¹ You use this conductor-category information for planning conductor routing as described in the system-level installation manual.

Status Indicators

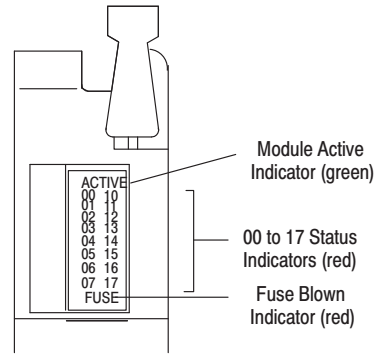

12220-1

Sample Connection Diagram - Driving a 1771-IAD Module with a 1771-OAD Module

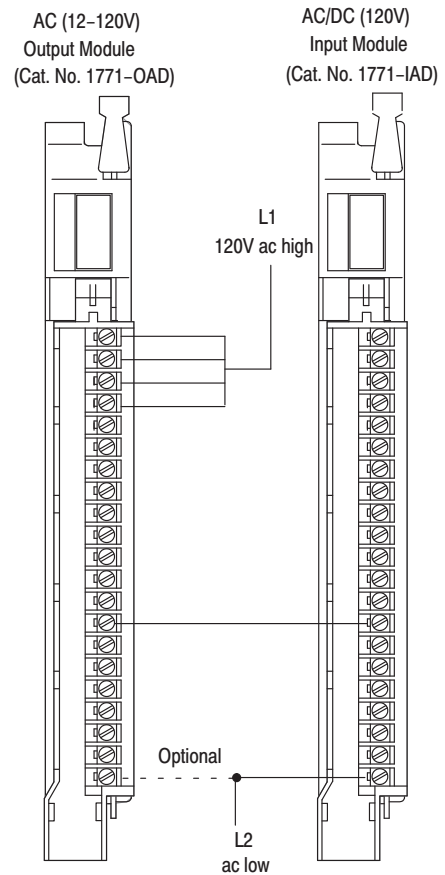

12219-1

AC Output Module (Cat. No. 1771-OAN)

Simplified Schematic

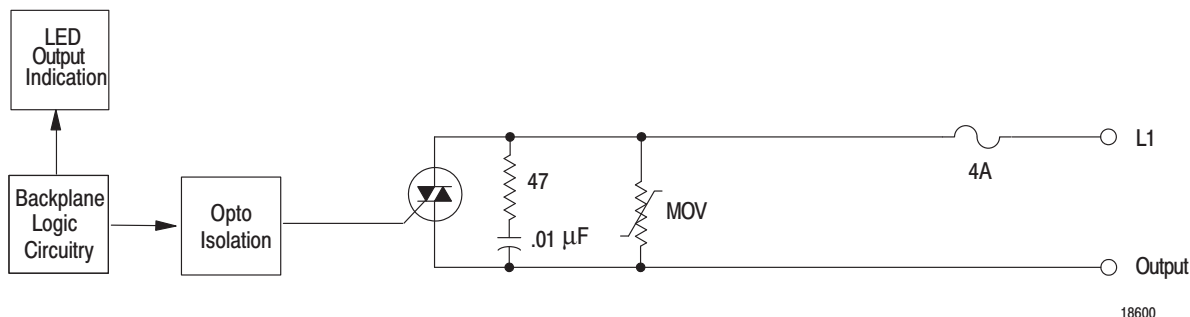

Application Notes

Product Compatibility. This module must be used with a 1771-A1B thru -A4B or later I/O chassis. An output from this module can drive an Allen-Bradley size 2 motor starter, provided its supply voltage does not drop below 120V ac.

Connection to Input Modules. You can use this module to directly drive terminals on ac/dc input modules (cat. nos. 1771-IA/IA2, -IAD, or -IAN).

Status Indicators. The front panel has 32 status indicators. The status indicators provide system logic side indication of individual outputs. Each indicator is lit when its corresponding output is energized

Connection Diagram

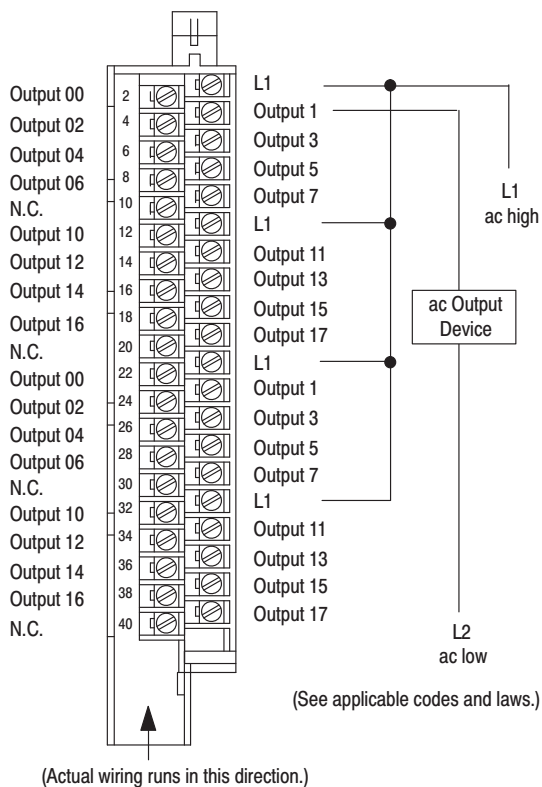

11852-1

AC Output Module (Cat. No. 1771-OAN)

Specifications (Cat. No. 1771-OAN)

Outputs per module	32 (4 groups of 8)
Module Location	1771-A1B thru -A4B or later I/O Chassis 1771-AM1, -AM2 I/O Chassis
Voltage Range	80 to 265V ac, 47-63Hz
Nominal Voltage	120V ac
Maximum Output Current	
Per Point	1.0A at 30°C; Derate linearly to 0.3A at 60°C
Per Group	2.0A at 30°C; Derate linearly to 0.6A at 60°C
Per Module	8.0A at 30°C; Derate linearly to 2.4A at 60°C
Maximum Surge Current	10A for 25ms at 1Hz and 30°C 10A for 25ms at 0.5Hz and 60°C
Minimum Load Current	10mA per output
Maximum On-state Voltage Drop	1.5V ac (rms) @ 1A
Maximum Off-state Leakage Current	2.3mA per output @ 230V ac, 60Hz 1.2mA per output @ 120V ac, 60Hz
Output Signal Delay	Off to On On to Off
	1.0ms maximum 9.3ms @ 60Hz, 11.0ms @ 50Hz (maximum)
Power Dissipation	16.2W (max); 1.0W (min)
Thermal Dissipation	55.4 BTU/hr (max); 3.4 BTU/hr (min)
Isolation Voltage	Isolation meets or exceeds UL Standard 508, and CSA Standard C22.2 No. 142.
Backplane Current	800mA @ 5V dc maximum
Environmental Conditions	
Operational Temperature	0° to 60°C (32° to 140°F)
Storage Temperature	-40° to 85°C (-40° to 185°F)
Relative Humidity	5 to 95% (without condensation)
Conductors	
Wire Size	14 gauge (2mm ²) stranded (max) ² 3/64 inch (1.2mm) insulation (max)
Category	1 ¹
Keying	Between 16 and 18 Between 22 and 24
Fuses	Four 4.0A, 250V normal blow fuses (1 per group)
Field Wiring Arm	1771-WN
Wiring Arm Screw Torque	7-9 inch-pounds
Agency Certification (when product or packaging is marked)	<ul style="list-style-type: none"> • CSA certified • CSA Class I, Division 2, Groups A, B, C, D certified • UL listed • CE marked for all applicable directives
Installation Instructions	1771-5.31

¹ You use this conductor-category information for planning conductor routing as described in the system-level installation manual
² 14 gauge wire connected to all terminals may not allow the cover on the field wiring arm to close. A smaller gauge wire may be required.

Status Indicators

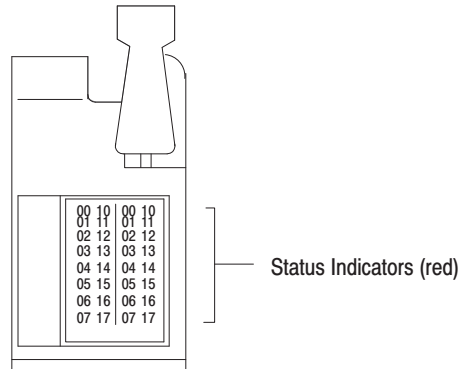

11853-I

Sample Connection Diagram – Driving a 1771-IAN Module with a 1771-OAN Module

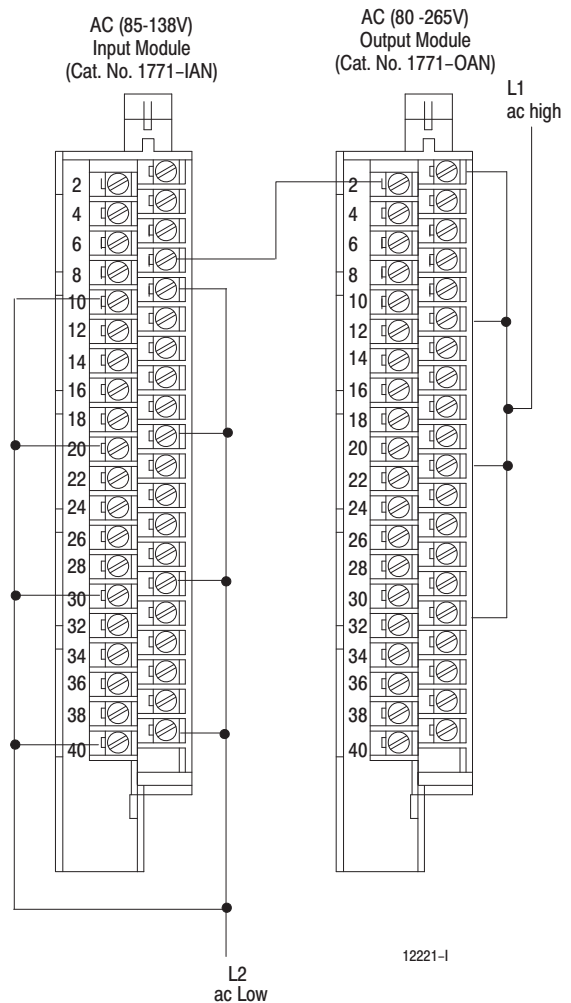

Isolated AC Output Module (Cat. No. 1771-OD Series C)

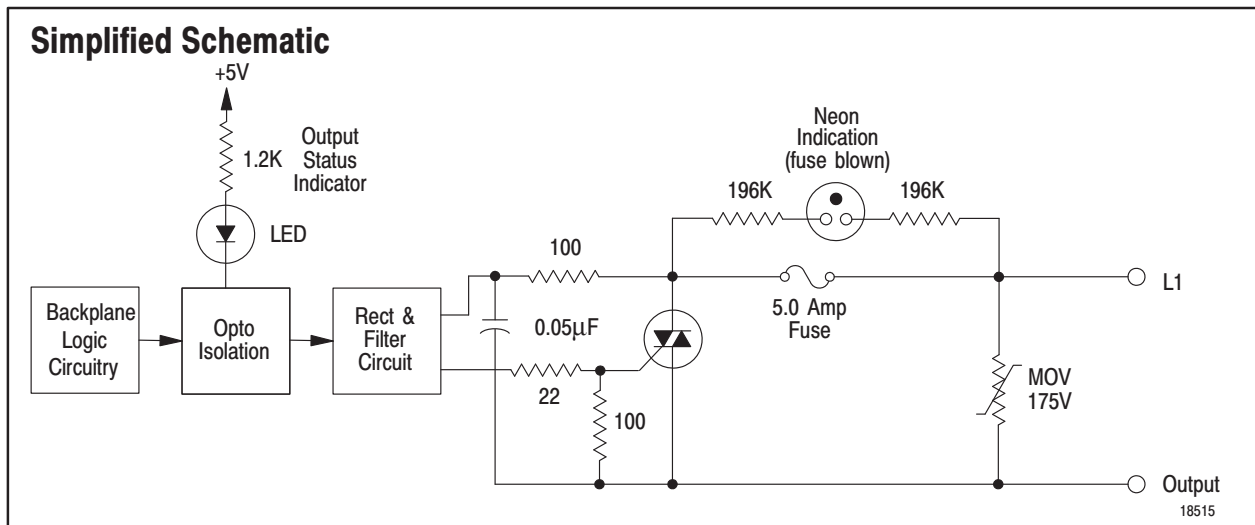

Application Notes

Device Compatibility. An output from this module can drive an Allen-Bradley Size 5 motor starter provided its supply voltage does not drop below 92V ac.

Output Leakage Current. The switching device in the output circuit is a triac. There is a small leakage current in the off state due to both triac and output snubber circuits. The maximum leakage current per output is 5mA at 138V ac. Nominal leakage current is 1mA. The on-state voltage drop across the output terminals is no more than 2.0V ac at 100mA.

Connection to Input Modules. You can use the output of (Cat. no. 1771-OD) to drive input modules (Cat. No. 1771-IA, -IA2, -ID, -IAD). However, you must connect a 2.5K ohm 10W resistor between the output and L2 (common). As an alternative you can connect an electrocube snubber (part number RG-1676-1). Inputs configured with the output module are not isolated from each other unless you are using the Cat. No. 1771-ID module.

Minimum/Maximum Load Current. The triac needs a minimum of 60mA load current to stay on. If your device pulls less than 60mA, the triac may not operate. The total continuous current the module supports is 6A (2A maximum per channel). If this rating is exceeded, the module overheats and damage may occur.

Status Indicators. The module has 12 status indicators. The top six red indicators show the state of each output and are driven by the logic circuitry on the programmable controller side of the module. These indicators light when their corresponding outputs are energized. The bottom six indicators display a blown-fuse condition at the respective output regardless of the state of the output. These outputs are driven by the user's power supply.

Connection Diagram

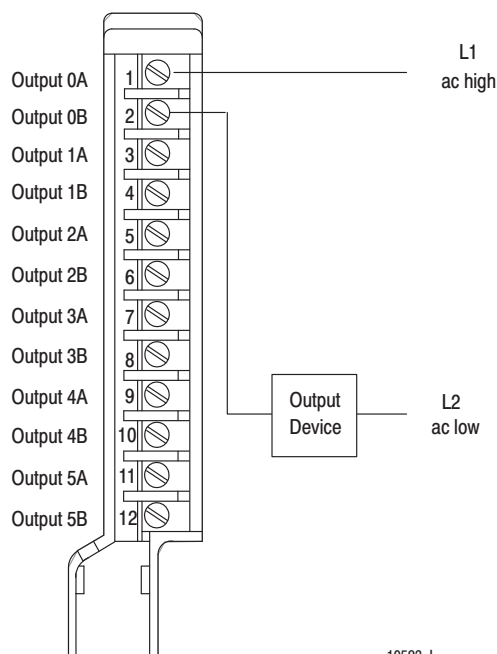

10593-I

Isolated AC Output Module (Cat. No. 1771-OD Series C)

Specifications (Cat. No. 1771-OD/C)

Outputs per Module	6	
Module Location	1771 I/O Chassis	
Voltage Rating	92 to 138V ac @ 47-63 Hz	
Output Current Rating (per channel)	2A per output (not to exceed 6A per module)	
Surge Current (maximum)	20A maximum for 100ms Repeatable every 5 seconds	
Load Current (minimum)	60mA per output	
On-state Voltage Drop	2V ac (max) at 100mA	
Off-state Leakage Current	5mA (max) per output at 138V ac	
Signal Delay	Off to On	1.0ms
	On to Off	8.3ms @ 60Hz
Power Dissipation	13.2 Watts (max); 1.2 Watts (min)	
Thermal Dissipation	45.2 BTU/hr (max); 4.1 BTU/hr (min)	
Backplane Current	225mA	
Isolation Voltage	Isolation meets or exceeds UL Standard 508, and CSA Standard C22.2 No. 142.	
Maximum Cable Length	1000 ft (304.8 m)	
Environmental Conditions		
Operational Temperature	0° to 60°C (32° to 140°F)	
Storage Temperature	-40° to 85°C (-40° to 185°F)	
Relative Humidity	5 to 95% (without condensation)	
Conductors	Wire Size	14 gauge (2mm ²) stranded maximum 3/64 inch (1.2mm) insulation maximum
	Category	1 ¹
Keying	Between 4 and 6 Between 30 and 32	
Fuse	5A, 250V 3AG normal blow fuses (1 per output) Buss AGC-5, Littelfuse 312005	
Field Wiring Arm	Catalog Number 1771-WD	
Wiring Arm Screw Torque	7-9 inch-pounds	
Agency Certification (when product or packaging is marked)	<ul style="list-style-type: none"> • CSA certified • CSA Class I, Division 2, Groups A, B, C, D certified • UL listed • CE marked for all applicable directives 	
Installation Instructions	1771-2.12	

¹ You use this conductor-category information for planning conductor routing as described in the system-level installation manual.

Status Indicators

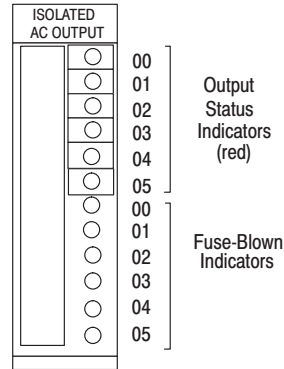

10595-1

Sample Connection Diagram – Driving a 1771-IAD Module with a 1771-OD Module

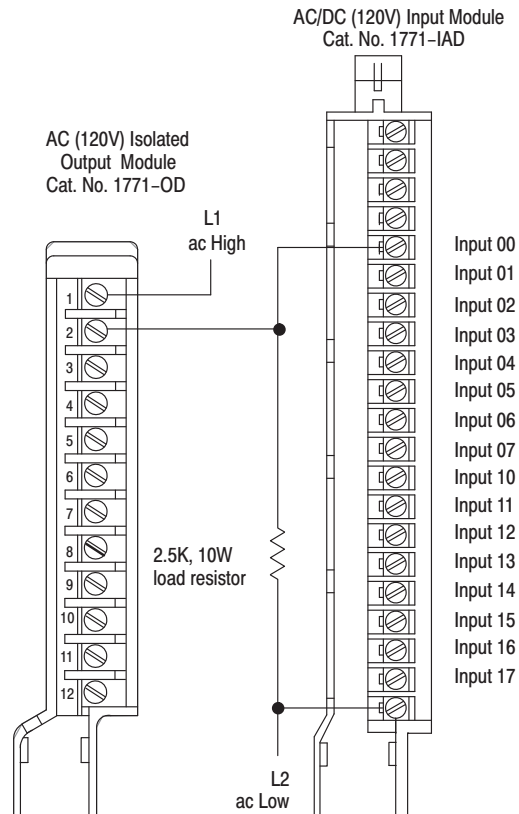

10594-1

Isolated AC Output Module (Cat. No. 1771-OD16)

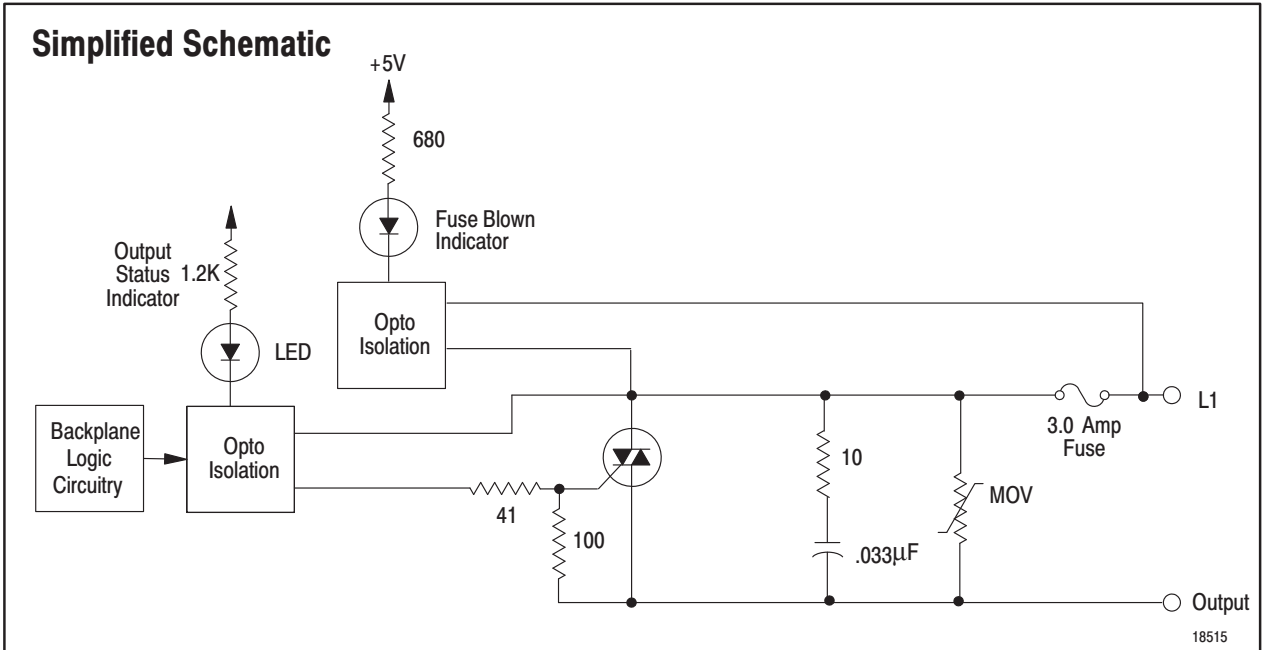

Application Notes

Device Compatibility. An output from this module can drive an Allen-Bradley Size 5 motor starter provided its supply voltage does not drop below 92V ac.

Product Compatibility. This module must be used with a 1771-A1B thru -A4B or later I/O chassis.

Connection to Input Modules. You can use an output of the 1771-OD16 module to drive an input of a 120V ac input module (1771-IA, -IA2, IAD, -ID or ID16). Inputs configured with the output module are not isolated from each other.

Status Indicators. The front panel has one green active indicator, one red fuse-blown indicator and 16 red status indicators. The active indicator lights when the module has started up and successfully initialized. The fuse-blown indicator lights when a fuse has cleared or been removed and the channel associated with that fuse has been turned "on." The fuse-blown circuit will not operate if the applied line voltage is above the module's specified minimum on-state voltage, and the output load current is less than or equal to 5mA. The fuse-blown indicator will reset after the fuse has been replaced and chassis power has been recycled. The indicators are provided for field side indication of individual outputs.

Connection Diagram

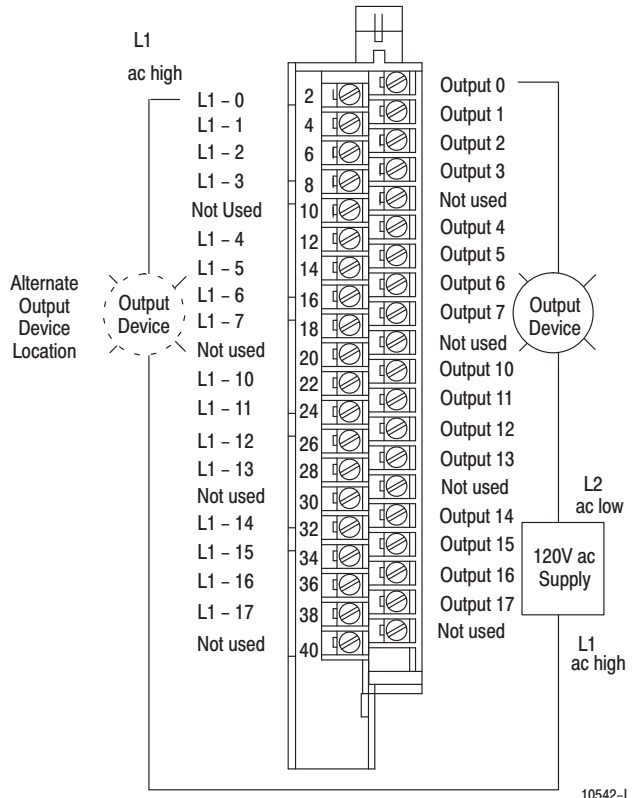

Isolated AC Output Module (Cat. No. 1771-OD16)

Specifications (Cat. No. 1771-OD16)

Outputs per Module	16
Module Location	1771-A1B thru -A4B or later I/O Chassis
Voltage Rating	74 to 138V ac, 47-63Hz
Current Rating (per channel)	5mA-2A continuous (max) 20A surge for 100ms; repeatable every 2 seconds 8A continuous per module (maximum)
Power Rating	3 Watts per output (max) @ 2A
On-state Voltage Drop (each output)	5.7V rms (max.) @ load current <70mA 1.5V rms (max.) @ load current >70mA
On-state Load Current	5mA minimum
Off-state Leakage Current	3.0mA max. @ 138V ac; 1.5mA (typical) @ 120V ac
Zero Voltage Turn-on	25V ac maximum; 15V ac typical
Signal Delay Times	
Off to On	8.8ms @ 60Hz max; 10.6ms @ 50Hz max
On to Off	8.8ms @ 60Hz max; 10.6ms @ 50Hz max (zero cross switching)
Power Dissipation	13.0 Watts (max); 1.0 Watts (min)
Thermal Dissipation	44.4 BTU/hr (max); 3.4 BTU/hr (min)
Backplane Current	200mA maximum
Isolation Voltage	Isolation meets or exceeds UL Standard 508, and CSA Standard C22.2 No. 142.
Maximum Cable Length	1000 ft (304.8 m)
Environmental Conditions	
Operational Temperature	0° to 60°C (32° to 140°F)
Storage Temperature	-40° to 85°C (-40° to 185°F)
Relative Humidity	5 to 95% (without condensation)
Conductors Wire Size	14 gauge (2mm ²) stranded maximum ² 3/64 inch (1.2mm) insulation maximum
Category	1 ¹
Keying	Between 22 and 24 Between 34 and 36
Fuses	3A 2AG Slo-Blo fuses (1 per output), Littelfuse P/N 229003
Optional Fuse Kit	Cat. No. 1771-FE (contains 5 fuses)
Field Wiring Arm	Catalog Number 1771-WN
Wiring Arm Screw Torque	7-9 inch-pounds
Agency Certification (when product or packaging is marked)	<ul style="list-style-type: none"> • CSA certified • CSA Class I, Division 2, Groups A, B, C, D certified • UL listed • CE marked for all applicable directives
Installation Instructions	1771-5.21

¹ You use this conductor-category information for planning conductor routing as described in the system-level installation manual.
² 14 gauge wire connected to all terminals may not allow the field wiring arm cover to close. A smaller gauge wire may be required.

Status Indicators

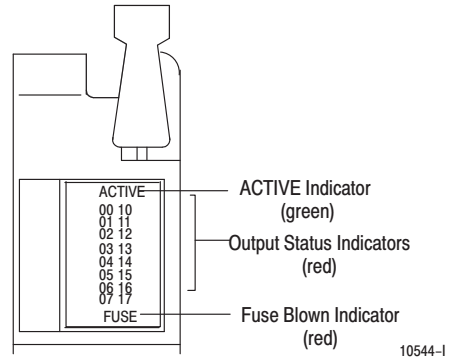

Sample Connection Diagram - Driving a 1771-ID16 with a 1771-OD16

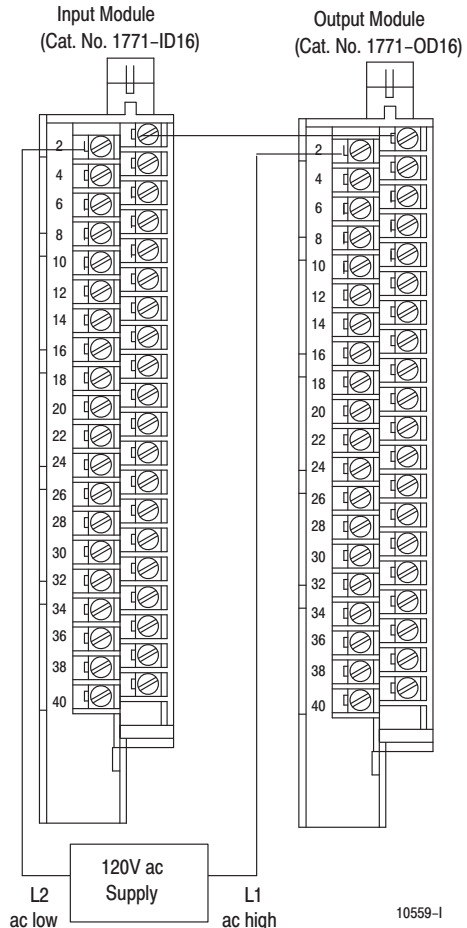

Isolated AC Output Module (Cat. No. 1771-ODD)

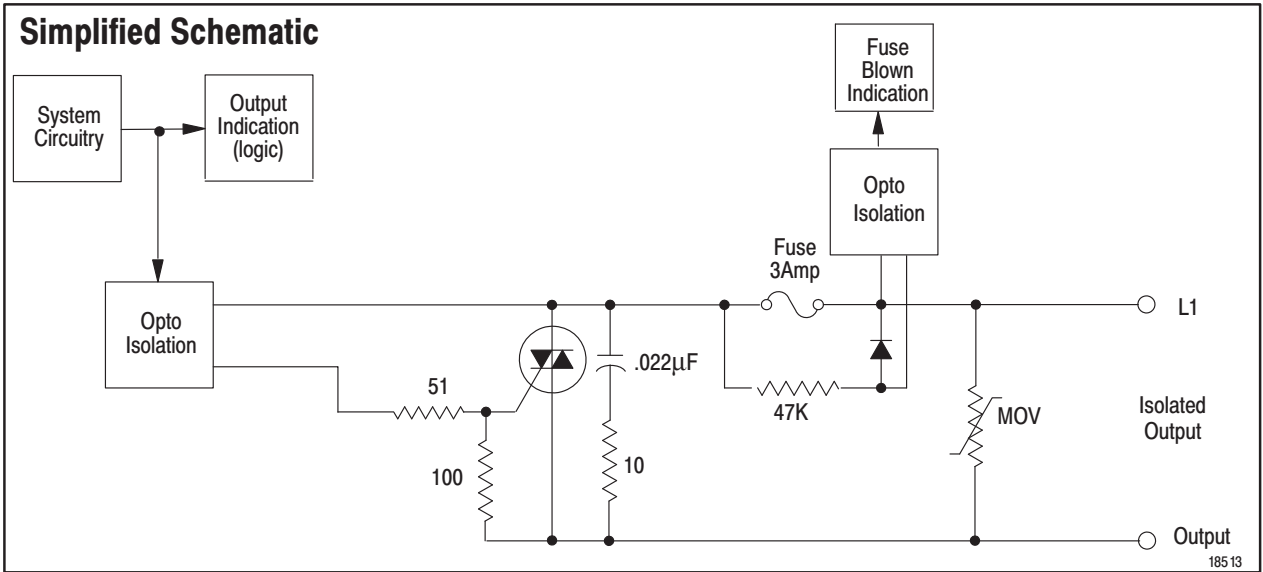

Application Notes

Device Compatibility. An output from this module can drive an Allen-Bradley Size 5 motor starter, provided its supply voltage does not drop below 92V ac.

Product Compatibility. This module must be used with a 1771-A1B thru -A4B or later I/O chassis.

Connection to Input Modules. You can use this module (Cat. No. 1771-ODD) to drive input modules (Cat. Nos. 1771-IA, -IA2, -IAD, -ID). Inputs configured with the output module are not isolated from each other unless you are using the 1771-ID or 1771-ID16.

Minimum/Maximum Load Current. The 1771-ODD module is designed for a 10mA minimum current on each output circuit. The total continuous current the module supports is 8A (2A maximum per channel). If this rating is exceeded, the module overheats and damage may occur.

Status Indicators. The module has 32 status indicators. The 16 indicators on the left side show the state of each output and are driven by the logic circuitry on the programmable controller side of the module. They light when their corresponding outputs are energized. The 16 indicators on the right side display a blown-fuse condition. A fuse-blown indicator displays a blown-fuse condition at the respective output regardless of the state of the output and are driven by the user's power supply.

Connection Diagram

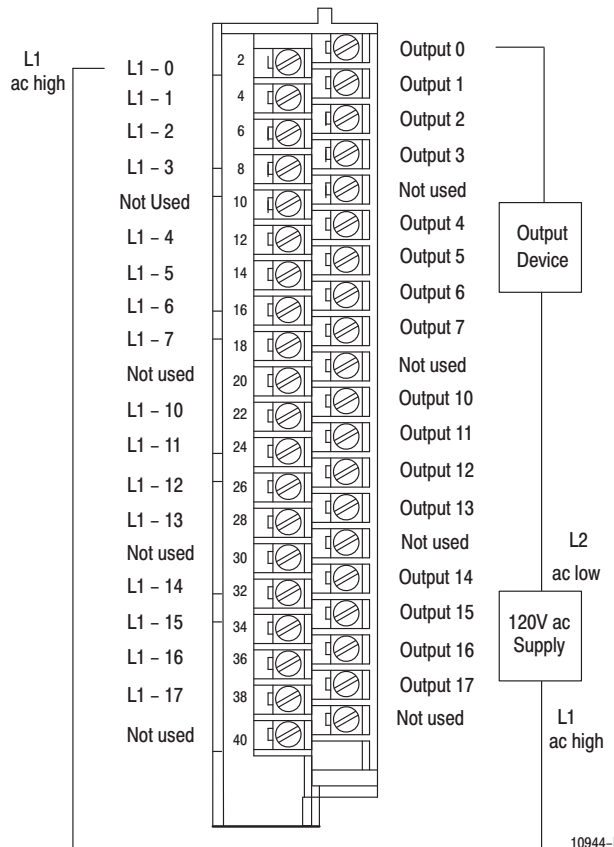

Isolated AC Output Module (Cat. No. 1771-ODD)

Specifications (Cat. No. 1771-ODD)

Outputs per Module	16
Module Location	1771-A1B thru -A4B or later I/O chassis, 1771-AM1, -AM2 I/O Chassis
Voltage Rating	85 to 138V ac, 47-63Hz
Current Rating (per channel)	10mA-2A continuous (max) 20A surge for 100ms; repeatable every 2 seconds 8A per module maximum
On-state Voltage Drop (each output)	6.5V RMS (max.) @ load current <65mA 1.5V RMS (max.) @ load current >65mA
On-state Load Current	10mA minimum
Off-state Leakage Current	3.0mA @ 138V ac; 1.5mA @ 120V ac
Signal Delay	Off to On 8.8ms @ 60Hz max; 10.6ms @ 50Hz max On to Off 8.8ms @ 60Hz max; 10.6ms @ 50Hz max (zero cross switching)
Power Dissipation	14.2 Watts (max); 0.1 Watts (min)
Thermal Dissipation	48.5 BTU/hr (max); 0.4 BTU/hr (min)
Backplane Current	420mA 5V dc ± 5%
Isolation Voltage	Isolation meets or exceeds UL Standard 508, and CSA Standard C22.2 No. 142.
Cable Length (maximum)	1000 ft (304.8 m)
Environmental Conditions	Operational Temperature 0° to 60°C (32° to 140°F) Storage Temperature -40° to 85°C (-40° to 185°F) Relative Humidity 5 to 95% (without condensation)
Conductors	Wire Size 14 gauge (2mm ²) stranded maximum ² 3/64 inch (1.2mm) insulation maximum Category 1 ¹
Keying	Between 4 and 6 Between 30 and 32
Fuses	3A 2AG Slo-Blo fuses (1 per output) Littelfuse part number 229003
Field Wiring Arm	Catalog Number 1771-WN
Wiring Arm Screw Torque	7-9 inch pounds
Agency Certification (when product or packaging is marked)	<ul style="list-style-type: none"> • CSA certified • CSA Class I, Division 2, Groups A, B, C, D certified • UL listed • CE marked for all applicable directives
Installation Instructions	1771-5.20

¹ You use this conductor-category information for planning conductor routing as described in the system-level installation manual.
² 14 gauge wire connected to all terminals may not allow the field wiring arm cover to close. A smaller gauge wire may be required.

Status Indicators

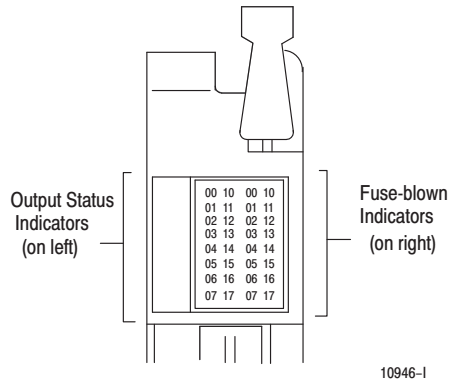

10946-1

Sample Connection Diagram – Driving a 1771-IAD with a 1771-ODD

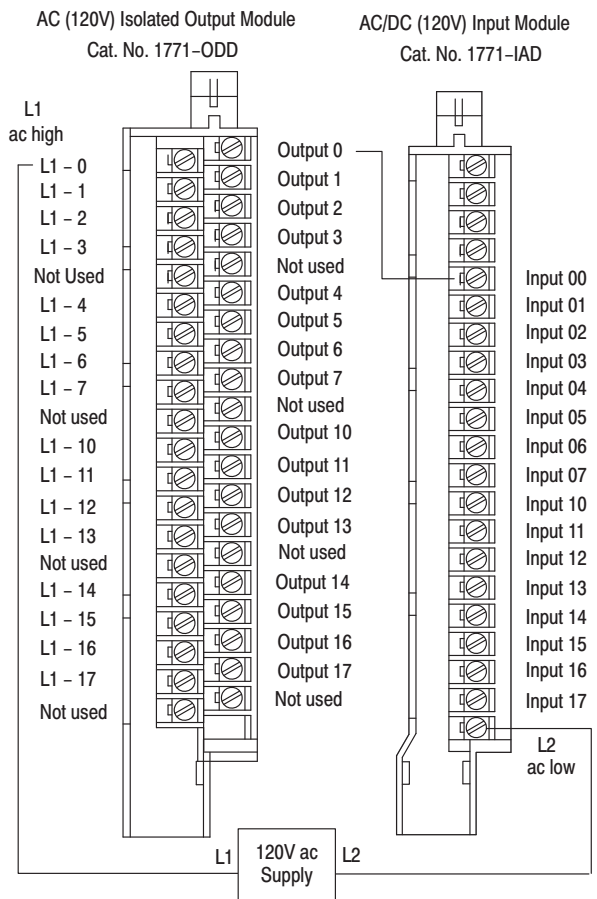

10945-1

Isolated AC Output Module (Cat. No. 1771-ODZ)

Simplified Schematic

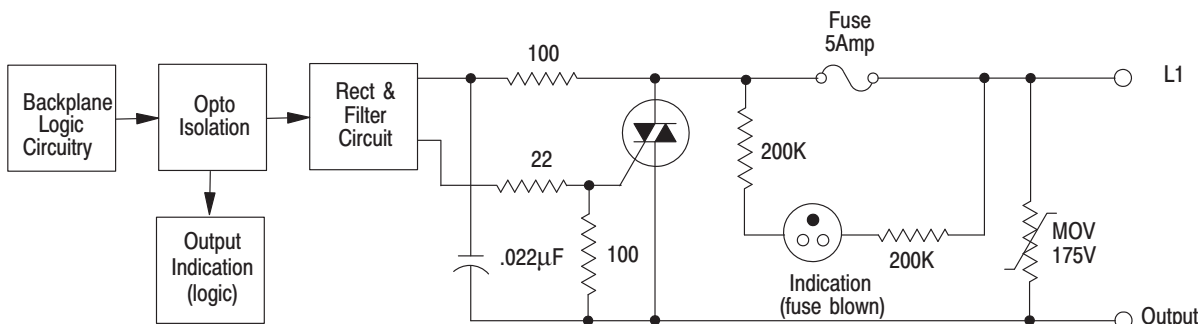

18512

Application Notes

Device Compatibility. Output from this module can drive an Allen-Bradley Size 5 motor starter, provided its supply voltage does not drop below 92V ac.

Connection to Input Modules. You can use an output of this module (Cat. No.1771-ODZ) to drive an input of a 120V ac input module (Cat. Nos. 1771-IA, -IA2, -ID, -IAD, -ID16, -IAN) to indicate status of turning on a motor starter.

Minimum/ Maximum Load Current. The triac needs a minimum of 15mA load current to stay on. If your device pulls less than 15mA, the circuit may not operate. The total continuous current the module supports is 6A (2A maximum per channel). If this rating is exceeded, the module overheats and damage may occur.

Status Indicators. The module has 16 status indicators. The red indicators show the state of each output and are driven by the logic circuitry on the programmable controller side of the module. They light when their corresponding outputs are energized. The 8 orange indicators display a fuse-blown condition at the respective output regardless of the state of the output and are driven by the user's power supply.

Connection Diagram

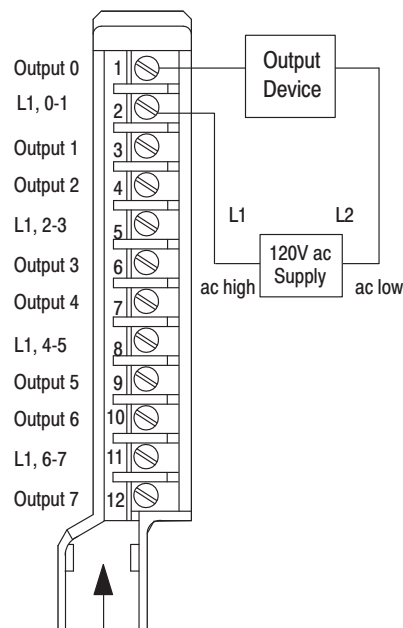

(Actual wiring runs in this direction.)

10422-1

Isolated AC Output Module (Cat. No. 1771-ODZ)

Specifications (Cat. No. 1771-ODZ)

Outputs per Module	8
Module Location	1771 I/O Chassis
Output Voltage Range	92 to 138V ac, 47 to 63Hz
Output Load Current (maximum)	2A per output, not to exceed 6A per module
Maximum Surge Current per Output and Module	20A for 100ms; repeatable every 5 seconds
Minimum Load Current	15mA per output
On-state Voltage Drop (max)	1.6V maximum at 2A
Off-state Leakage Current (max)	2mA per output at 138V ac
Signal Delay Times	Off to On: 1ms On to Off: 8.3ms @ 60Hz
Power Dissipation	11.4 Watts (max.); 1.8 Watts (min.) per module
Thermal Dissipation	38.9 BTU/hr (max); 6.14 BTU/hr (min.)
Backplane Current	350mA @ 5V dc ± 5%
Isolation Voltage	Isolation meets or exceeds UL Standard 508, and CSA Standard C22.2 No. 142.
Environmental Conditions	
Operational Temperature	0 to 60°C (32 to 140°F)
Storage Temperature	-40 to 85°C (-40 to 185°F)
Relative Humidity	5 to 95% without condensation
Conductors	
Wire Size	14 gauge (2mm ²) stranded (max) 3/64 inch (1.2mm) insulation (max)
Category	1 ¹
Keying	Between 4 and 6 Between 34 and 36
Fuse	5A, 250V 3AG Normal Blow, Littelfuse part number 312005
Field Wiring Arm	Cat. No. 1771-WD
Wiring Arm Screw Torque	7-9 inch pounds
Agency Certification (when product or packaging is marked)	<ul style="list-style-type: none"> • CSA certified • CSA Class I, Division 2, Groups A, B, C, D certified • UL listed • CE marked for all applicable directives
Installation Instructions	1771-2.130

¹ You use this conductor-category information for planning conductor routing as described in the system-level installation manual.

Status Indicators

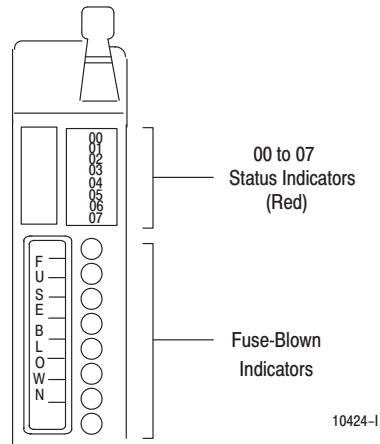

10424-1

Sample Connection Diagram – Driving a 1771-IA Module with a 1771-ODZ Module

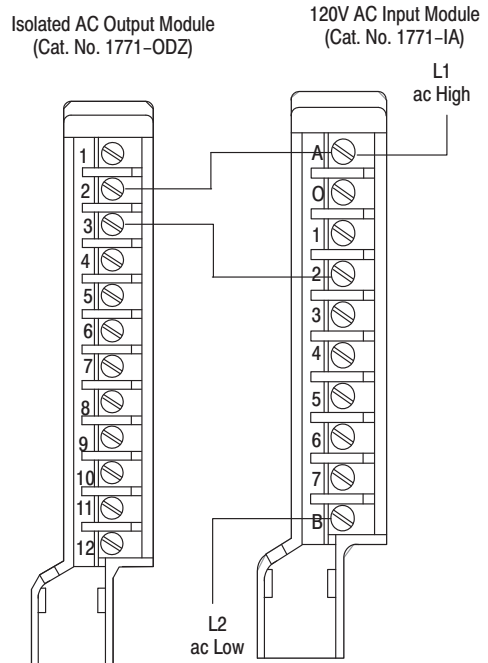

10423-1

AC Output Module (Cat. No. 1771-OM)

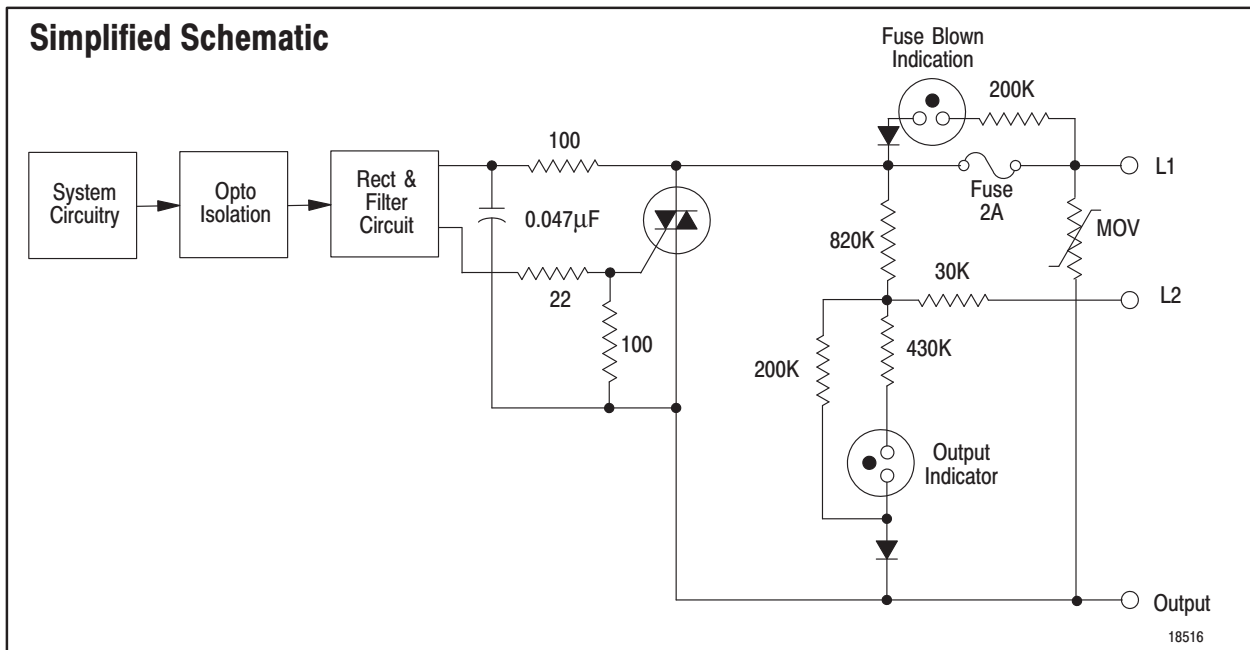

Application Notes

Device Compatibility. You can drive an Allen-Bradley motor starter size 4, provided its supply voltage does not drop below 184 V.

Minimum/Maximum Load Current. The module needs a minimum load current of 60mA to stay on. If your device pulls less than 60mA the triac will not operate. The maximum load current the module can deliver is 2A per output, not to exceed 6A total per module.

Connection to Input Modules. You can use an ac (220/240V) output module (cat. no. 1771-OM) to drive terminals on an ac (220/240V) input module (cat. no. 1771-IM), but you must connect a 3.3K ohm, 20 Watt resistor between the output terminal and L2 (common). You can also use an ac (220/240V) output module (cat. no. 1771-OM) to drive terminals on an ac (220V) input module (cat. no. 1771-IMD), but you must connect a 10K ohm, 10 Watt resistor or an electrocube snubber (part number RG-1676-32) between the output terminal and L2 (common). **Use the same power source to power both modules to ensure proper phasing, and to prevent module damage.**

Status Indicators. The front panel has eight orange status indicators and one orange fuse-blown indicator. The status indicators light when the corresponding output is energized. The fuse-blown indicator lights when any of the 8 fuses in the module are blown. The indicators are provided for field side indication of individual outputs.

Connection Diagram

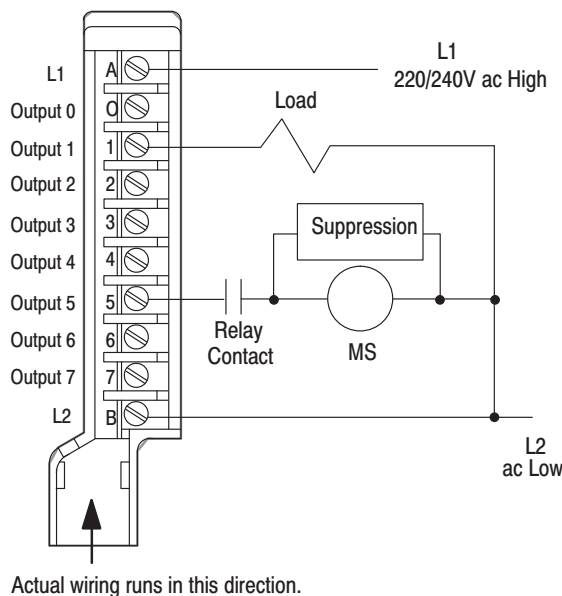

Actual wiring runs in this direction.

11896-1

AC Output Module (Cat. No. 1771-OM)

Specifications (Cat. No. 1771-OM)

Outputs per Module	8	
Module Location	1771 I/O chassis	
Output Voltage Range	184 to 250V ac @ 47 - 63Hz	
Output Current Rating	2A per output — not to exceed 6A per module	
Surge Current (maximum) per Output and Module	20A for 100ms, repeatable every 10 seconds	
Load Current (minimum)	60mA per output @ 220V ac, 60Hz	
On-State Voltage Drop (max.)	1.6V at 2A	
Off-State Leakage Current (max.)	2mA per output @ 220V ac	
Signal Delay	Off to On	1.0ms
	On to Off	8.3ms @ 60Hz
Power Dissipation	13.2 Watts (max.), 1.2 Watts (min.)	
Thermal Dissipation	45.1 BTU/hr (max.), 4.1 BTU/hr (min.)	
Backplane Current	225mA @ 5V dc ±5%	
Isolation Voltage	Isolation meets or exceeds UL Standard 508, and CSA Standard C22.2 No. 142.	
Environmental Conditions		
Operational Temperature	0° to 60°C (32° to 140°F)	
Storage Temperature	-40° to 85°C (-40° to 185°F)	
Relative Humidity	5 to 95% (without condensation)	
Conductors	Wire Size	14 gauge (2mm ²) stranded maximum
	Category	3/64 inch (1.2mm) insulation maximum 2 ¹
Keying	Between 6 and 8 Between 28 and 30	
Fuse	2A, 250V 3AG Normal Blow (1 per output) Buss Fuse AGC-2, Littelfuse 312002	
Field Wiring Arm	Catalog Number 1771-WA	
Wiring Arm Screw Torque	7-9 inch pounds	
Agency Certification (when product or packaging is marked)	<ul style="list-style-type: none"> • CSA certified • CSA Class I, Division 2, Groups A, B, C, D certified • UL listed • CE marked for all applicable directives 	
Installation Instructions	1771-2.18	

¹ You use this conductor-category information for planning conductor routing as described in the system-level installation manual.

Status Indicators

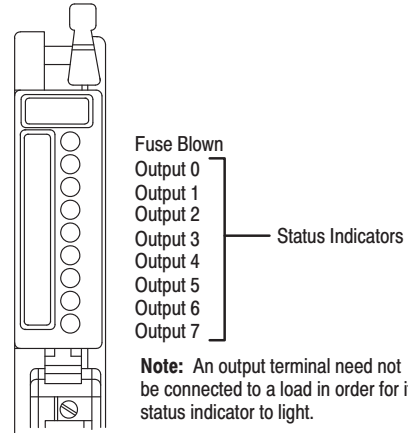

11898-I

Sample Connection Diagram – Driving a 1771-IMD Module with a 1771-OM Module

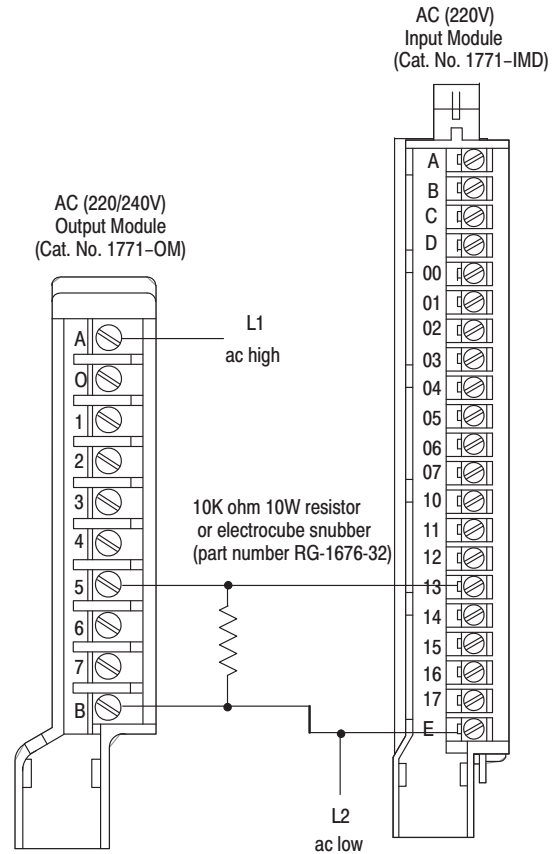

11897-I

AC Output Module (Cat. No. 1771-OMD Series B)

Simplified Schematic

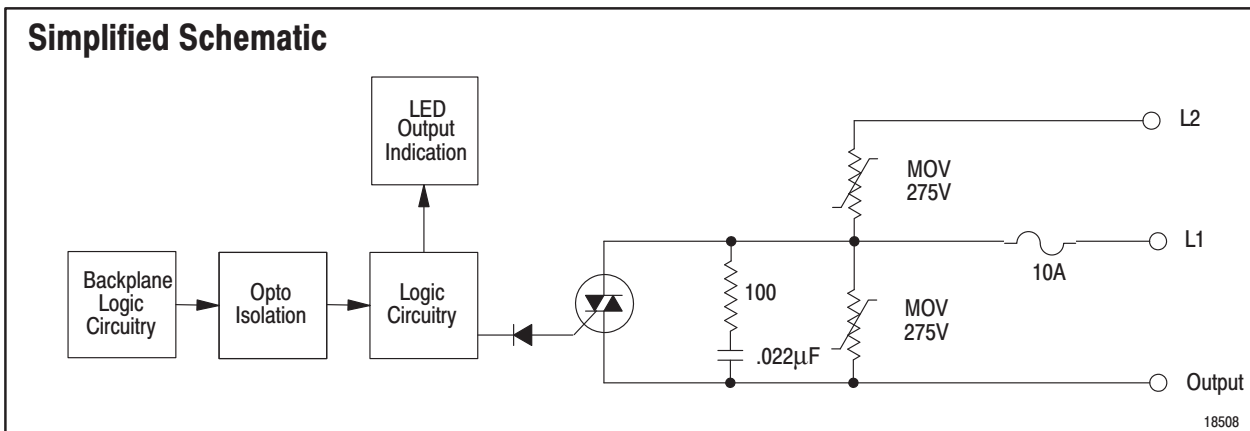

Application Notes

Device Compatibility. An output from this module can drive an Allen-Bradley size 5 motor starter provided its supply voltage does not drop below 184V.

Product Compatibility. This module must be used with a 1771-A1B thru -A4B or later I/O chassis.

Connection to Wiring Arm. You need 4 ac (L1) connections on the wiring arm to accommodate the total surge rating on the module without overstressing any single connection on the field wiring arm. Use the copper four-position jumper (part number 976328-01) that comes with the wiring arm supplied with the 1771-OMD module for distributing ac (L1) across the connections.

Connection to Input Modules. This module can directly drive terminals on ac/dc input modules (cat. nos. 1771-IMD). You can also use a 1771-OMD to drive ac/dc input modules (cat. nos. 1771-IM, -ID01) but you must connect a 10K ohm 10W resistor between the outputs and L2 (common). As an alternative you can use an electrocube snubber (part number RG-1676-32). **Use the same ac power source to ensure proper phasing and prevent module damage.**

Setting the Fault Mode. Use the jumper below to set the fault mode to the last state (LS) or reset position.

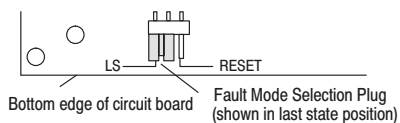

Status Indicators. The front panel has one green, module-active indicator, 16 red status indicators and one red fuse-blown indicator. The 1771-OMD performs diagnostics in a handshaking mode when first powered up. Upon successful completion of the diagnostics, the module-active indicator lights. It turns off if a fault occurs in the data paths or the opto-isolators. Each status indicator provides system logic side indication of individual outputs. They light when the corresponding output is energized.

Connection Diagram

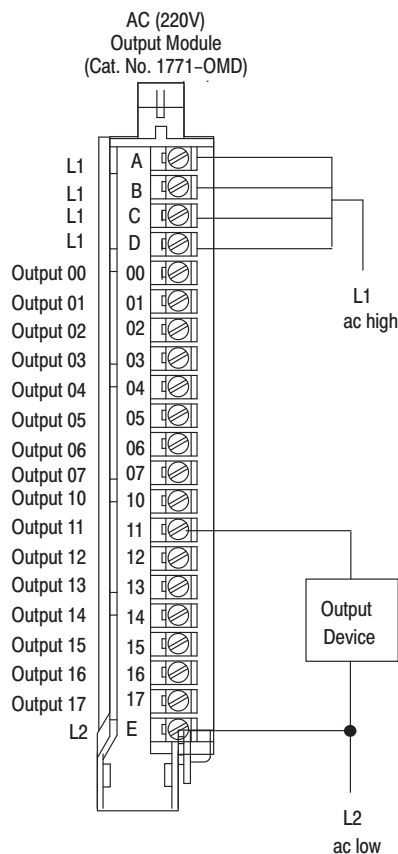

11924-1

AC Output Module (Cat. No. 1771-OMD Series B)

Specifications (Cat. No. 1771-OMD/B)

Outputs per Module	16
Module Location	1771-A1B thru -A4B or later I/O chassis 1771-AM1, -AM2 I/O chassis
Output Voltage Range	184 to 250V ac @ 47 – 63Hz
Output Current Rating	2A per output – not to exceed 8A per module
Surge Current (maximum)	25A per output for 100ms, repeatable every 1 second 25A per module for 100ms, repeatable every 1 second
Load Current (minimum)	10mA per output @ 220V ac, 60Hz
On-State Voltage Drop	1.5V at 2A (max.)
Off-State Leakage Current	4mA per output @ 220V ac (max.)
Signal Delay	Off to On 1.0ms On to Off 8.3–9.1ms @ 60Hz
Power Dissipation	17.3 Watts (max.); 3.7 Watts (min.)
Thermal Dissipation	59.0 BTU/hr (max.); 12.6 BTU/hr (min.)
Backplane Current	700mA @ 5V dc ±5%
Isolation Voltage	Isolation meets or exceeds UL Standard 508, and CSA Standard C22.2 No. 142.
Environmental Conditions	
Operational Temperature	0° to 60°C (32° to 140°F)
Storage Temperature	-40° to 85°C (-40° to 185°F)
Relative Humidity	5 to 95% without condensation
Conductors	Wire Size 14 gauge (2mm ²) stranded maximum 3/64 inch (1.2mm) insulation maximum Category 1 ¹
Keying	Between 2 and 4 Between 6 and 8
Fuse	10A, 250V rectifier fuse (1/4 x 1-1/4 inch), Littelfuse PN 322010 3AB
Field Wiring Arm	
Standard	Catalog Number 1771-WH
Optional Fused	Catalog Number 1771-WHF, -WHFB
Wiring Arm Screw Torque	7-9 inch pounds
Agency Certification (when product or packaging is marked)	<ul style="list-style-type: none"> • CSA certified • CSA Class I, Division 2, Groups A, B, C, D certified • UL listed • CE marked for all applicable directives
Installation Instructions	1771-5.26

¹ You use this conductor-category information for planning conductor routing as described in the system-level installation manual.

Status Indicators

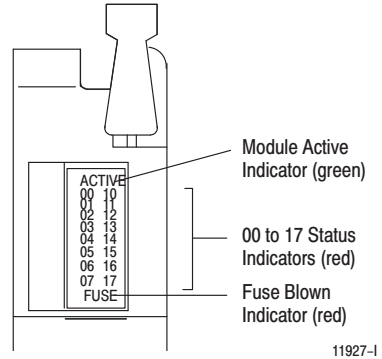

11927-1

Sample Connection Diagram – Driving a 1771-IM Module with a 1771-OMD Module

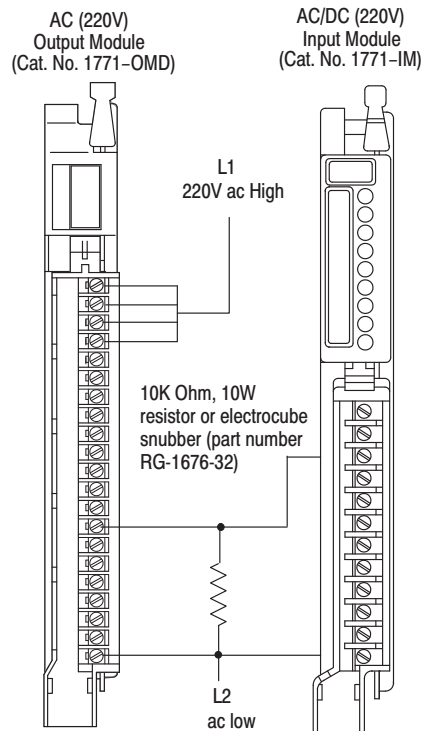

Note: 1771-OMD output voltage range is 184–250V ac. However, the on-state voltage range of the 1771-IM is 184–276V ac.

11926-1

AC Output Module (Cat. No. 1771-ON)

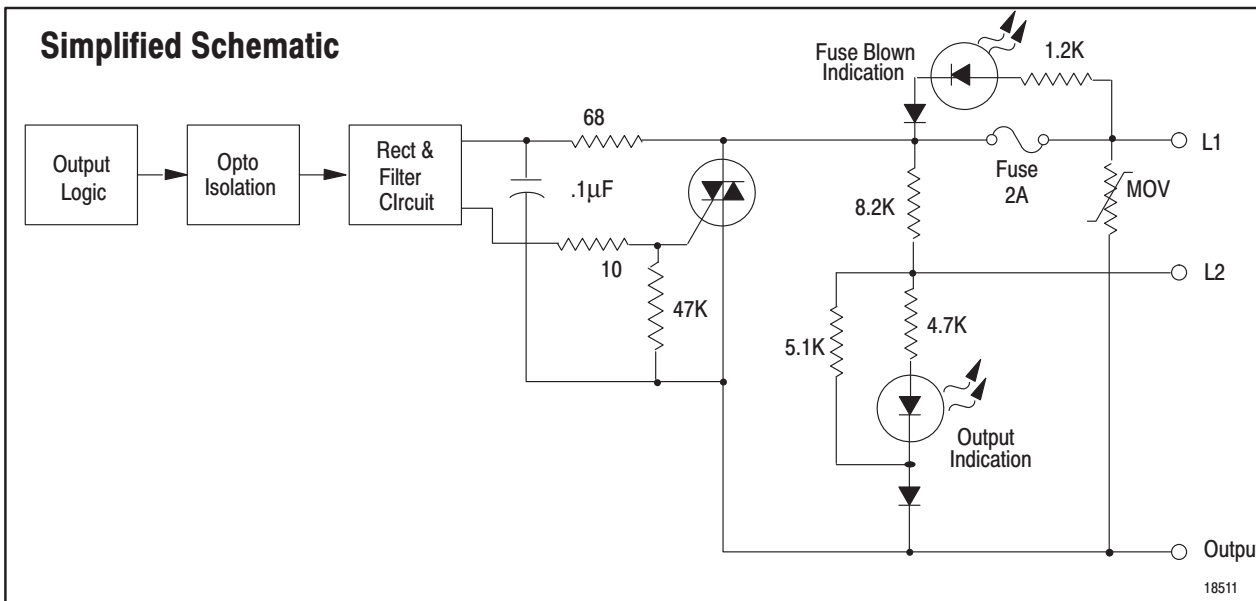

Application Notes

Device Compatibility. An output on the 1771-ON module can drive an Allen-Bradley motor starter up to a size 3, provided its supply voltage does not drop below 20V ac.

Connection to Input Modules. You can use an ac (24V) output module (Cat. No. 1771-ON) to drive an ac (24V) input module (Cat. No. 1771-IN) but you must connect a 250 ohm 5W resistor between the output terminal and L2 (common). When using a (Cat. No. 1771-ON) to drive an ac (24V) input module (Cat. No. 1771-IND) connect a 470 ohm, 3W resistor between the output terminal and L2 (common). Use the same ac power source to power both modules to ensure proper phasing and prevent module damage.

Status Indicators. The front panel has eight red status indicators and a fuse-blown indicator. The top indicator lights when a fuse has blown. The eight status indicators light when the corresponding output is energized. The indicators are provided for field side indication of individual outputs.

Connection Diagram

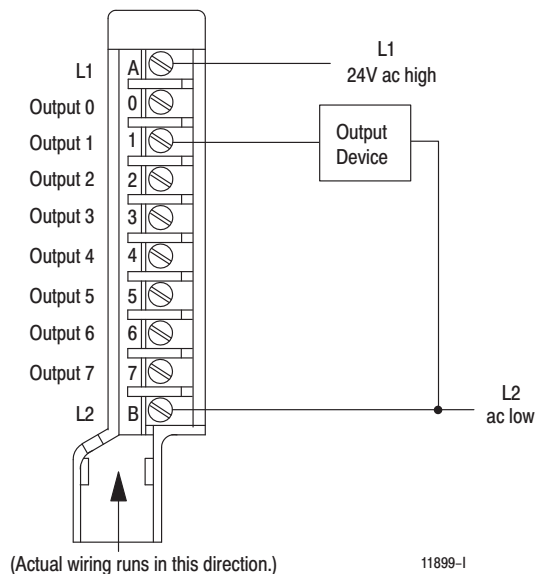

AC Output Module (Cat. No. 1771-ON)

Specifications (Cat. No. 1771-ON)

Outputs per Module	8
Module Location	1771 I/O chassis
Output Voltage Range	20 to 30V ac @ 47 - 63Hz
Nominal Output Voltage	24V ac, 50/60Hz
Output Current Rating (maximum)	1.5A per output - not to exceed 6A per module
Surge Current (maximum) per Output and Module	4A for 10msec
Minimum Load Current	100mA per output @ 24V ac, 60Hz
On State Voltage Drop (max.)	2V at 100mA
Off State Leakage Current (max.)	4mA per output @ 30V ac
Signal Delay	Off to On On to Off
	1.0ms 8.3ms @ 60Hz
Power Dissipation	13.2 Watts (max.), 1.2 Watts (min.)
Thermal Dissipation	45.1 BTU/hr (max.), 4.1 BTU/hr (min.)
Backplane Current	225mA @ 5V dc ± 5%
Isolation Voltage	Isolation meets or exceeds UL Standard 508, and CSA Standard C22.2 No. 142.
Environmental Conditions	
Operational Temperature	0° to 60°C (32° to 140°F)
Storage Temperature	-40° to 85°C (-40° to 185°F)
Relative Humidity	5 to 95% (without condensation)
Conductors	Wire Size Category
	14 gauge (2mm ²) stranded maximum 3/64 inch (1.2mm) insulation maximum 1 ¹
Keying	Between 4 and 6 Between 12 and 14
Fuse	250V 2A Normal Blow Bussman Fuse AGC-2 Littelfuse 312002
Field Wiring Arm	Catalog Number 1771-WA
Wiring Arm Screw Torque	7-9 inch pounds
Agency Certification (when product or packaging is marked)	<ul style="list-style-type: none"> • CSA certified • CSA Class I, Division 2, Groups A, B, C, D certified • UL listed • CE marked for all applicable directives
Installation Instructions	1771-2.42

¹ You use this conductor-category information for planning conductor routing as described in the system-level installation manual.

Status Indicators

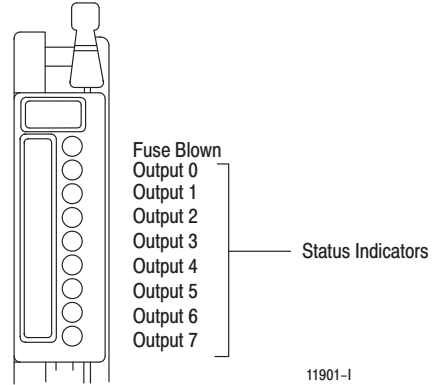

Sample Connection Diagram - Driving a 1771-IN Module with a 1771-ON Module

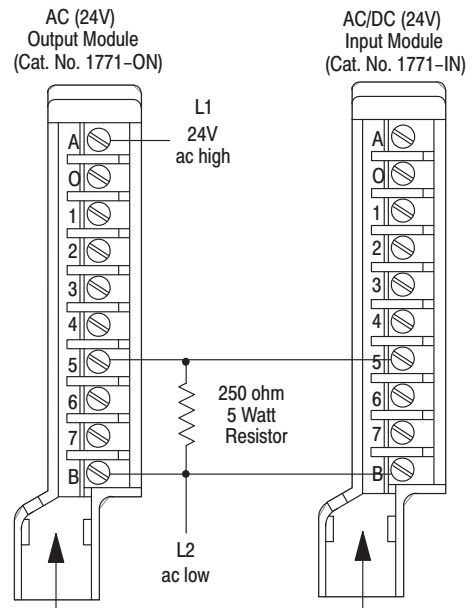

11900-I

AC Output Module (Cat. No. 1771-OND Series B)

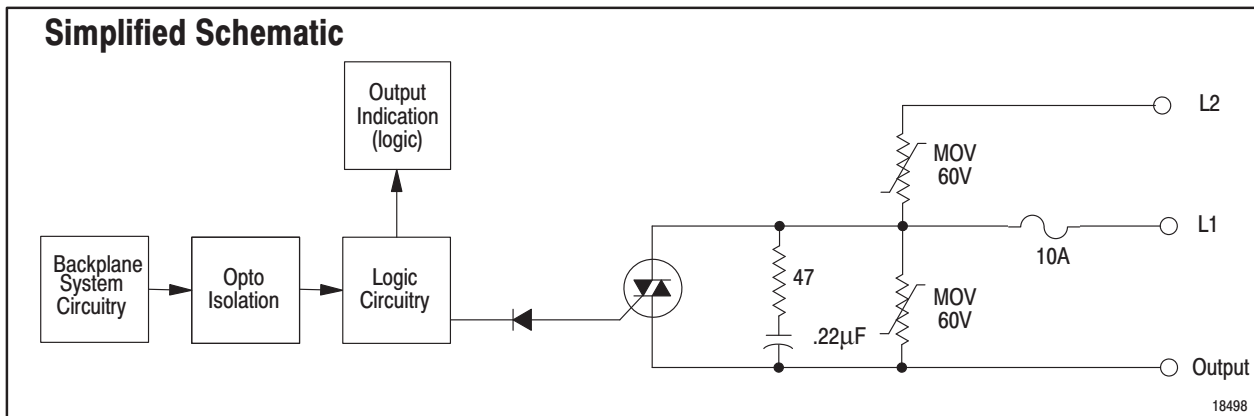

Application Notes

Device Compatibility. An output from this module can drive an Allen-Bradleysize 3 motor starter provided its supply voltage does not drop below 20 V ac.

Product Compatibility. This module must be used with a 1771-A1B thru -A4B or later I/O chassis.

Connection to Wiring Arm. You need 4 ac (L1) connections on the wiring arm to accommodate the total required surge rating on the module without over stressing any single connection on the field wiring arm. Make ac (L1) connection to the wiring arm using the copper four-position jumper (pt. no. 976328-01) supplied with the field wiring arm to connect the top 4 terminals.

Connection to Input Modules. You can use an ac (24V) output module (cat. no. 1771-OND) to directly drive terminals on an ac input module (cat. no. 1771-IND). You can also use an output module (cat. no. 1771-OND) to drive an ac (24V) input module (cat. no. 1771-IN) but you must connect a 250 ohm, 5W resistor between the output terminal and L2 (common). **Use the same power source to power both modules to ensure proper phasing and to prevent module damage.**

Setting the Fault Mode. Use the jumper below to set the fault mode to the last state (LS) or reset position.

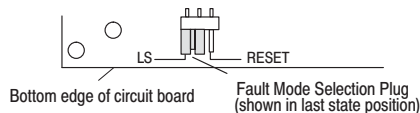

Status Indicators. The module front panel has one green module-active indicator, 16 red status indicators and one red fuse-blown indicator. The 1771-OND performs diagnostics in a handshaking mode when first powered up. Upon successful completion of the diagnostics, the green module-active indicator lights. It turns off if a fault occurs in the data paths or the opto-isolators. The status indicators provide system logic side indication of individual outputs. They light when the corresponding output has been energized.

Connection Diagram

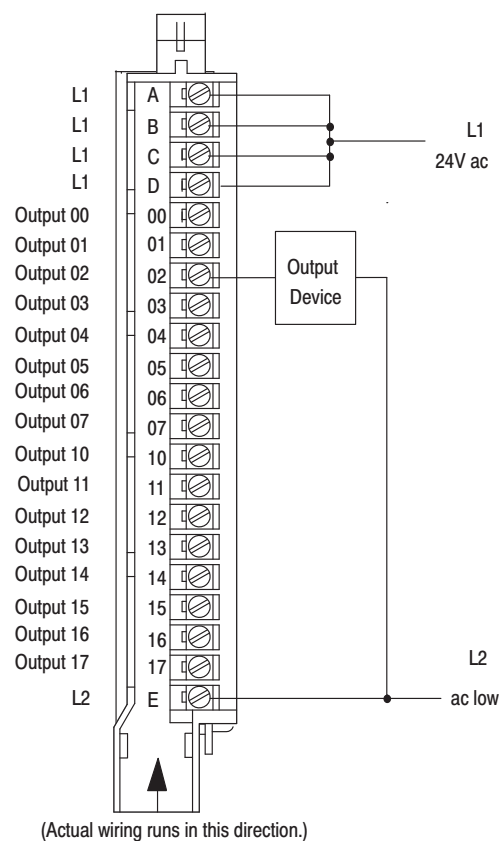

10674-1

AC Output Module (Cat. No. 1771-OND Series B)**Specifications (Cat. No. 1771-OND/B)**

Outputs per Module	16	
Module Location	1771-A1B thru -A4B I/O chassis 1771-AM1, -AM2 I/O Chassis	
Output Voltage Range	10 to 60V ac @ 47 - 63Hz	
Output Current Rating	2A per output —not to exceed 8A per module	
Surge Current (maximum)	25A per output for 100ms, repeatable every 1 second 25A per module for 100ms, repeatable every 1 second	
Load Current (minimum)	50mA per output @ 24V ac, 60Hz	
On-State Voltage Drop (max.)	1.6V at 2A	
Off-State Leakage Current (max.)	3mA per output @ 24V ac	
Signal Delay	Off to On On to Off	1.0ms 8.3-9.1ms @ 60Hz
Power Dissipation	16.5 Watts (max.); 3.7 Watts (min.)	
Thermal Dissipation	56.2 BTU/hr (max.); 12.6 BTU/hr (min.)	
Backplane Current	700mA @ 5V dc \pm 5%	
Isolation Voltage	Isolation meets or exceeds UL Standard 508, and CSA Standard C22.2 No. 142.	
Environmental Conditions		
Operational Temperature	0° to 60°C (32° to 140°F)	
Storage Temperature	-40° to 85°C (-40° to 185°F)	
Relative Humidity	5 to 95% (without condensation)	
Conductors	Wire Size	14 gauge (2mm ²) stranded maximum 3/64 inch (1.2mm) insulation maximum
	Category	1 ¹
Keying		Between 20 and 22 Between 32 and 34
Fuse		10A, 250V rectifier fuse (1/4 x 1-1/4 inch), Littelfuse PN 322010
Field Wiring Arm Standard		Catalog Number 1771-WH Catalog Number 1771-WHF, -WHFB
Optional Fused		
Wiring Arm Screw Torque		7-9 inch-pounds
Agency Certification (when product or packaging is marked)		<ul style="list-style-type: none"> • CSA certified • CSA Class I, Division 2, Groups A, B, C, D certified • UL listed • CE marked for all applicable directives
Installation Instructions		1771-5.41

¹ You use this conductor-category information for planning conductor routing as described in the system-level installation manual.

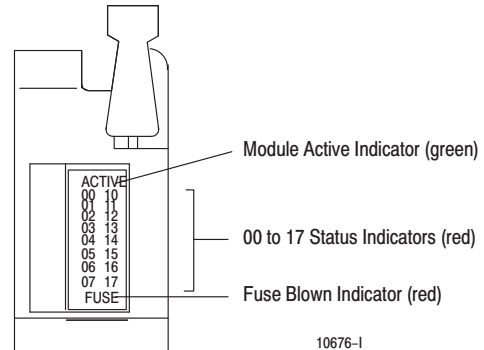
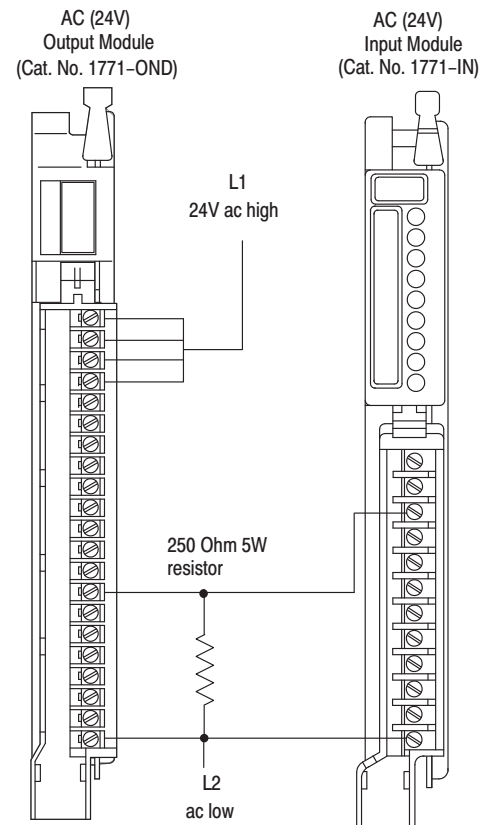
Status Indicators**Sample Connection Diagram – Driving a 1771-IN Module with a 1771-OND Module**

Protected AC Output Module (Cat. No. 1771-OP)

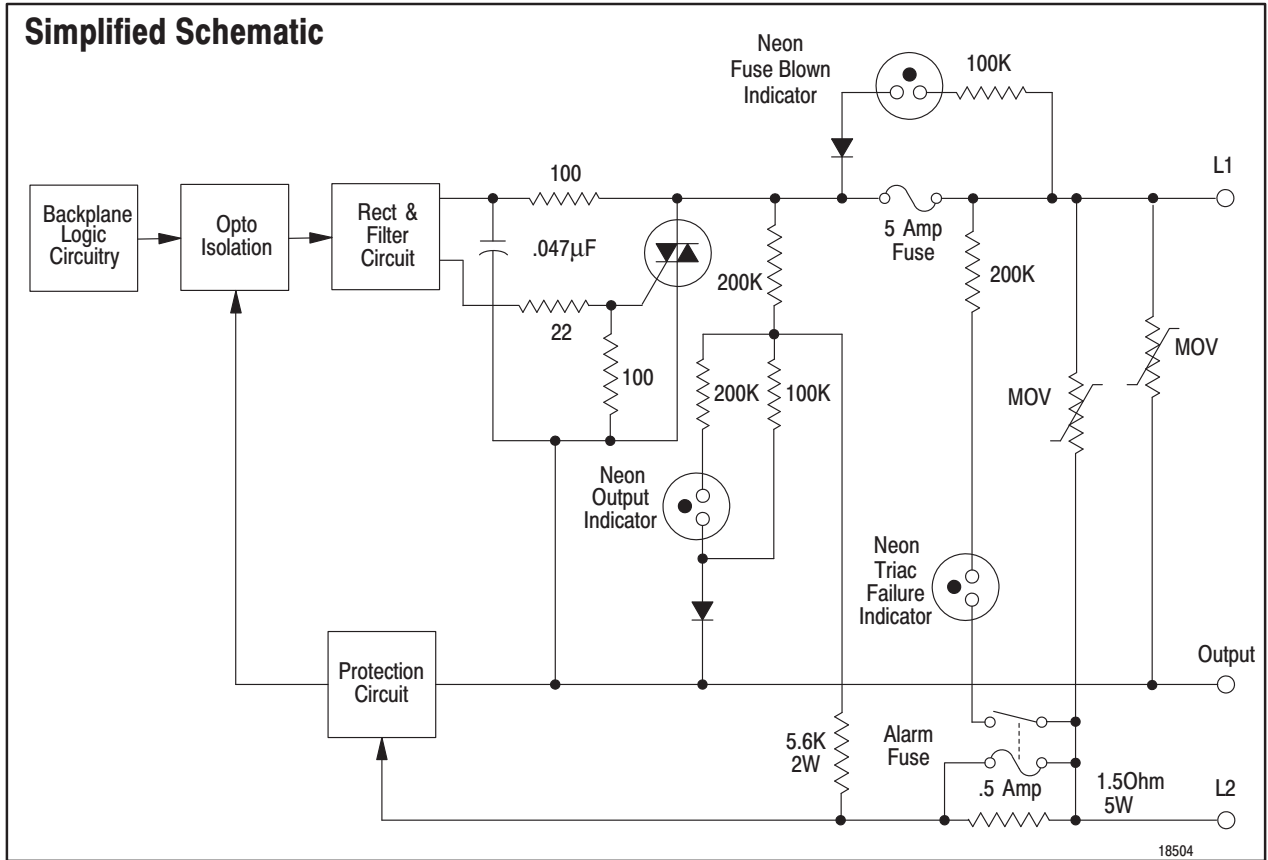

Application Notes

Device Compatibility. An output from this module can drive an Allen-Bradley Size-5 motor starter, provided its supply voltage does not drop below 92V ac.

Minimum/Maximum Load Current. The maximum load current the module can deliver is 2A per output not to exceed 6A per module. The triac needs a minimum of 80mA of load current to stay on.

Connection to Input Modules. The cat. no. 1771-OP can drive an input of a 120V ac input module (1771-IA, -IA2, -IAD, -ID). However, you must connect a 2.5K ohm, 10W external resistor or an electrocube (part number RG-1676-1) between the output terminal and L2 (common). **Use the same ac power source to power both modules to ensure proper phasing and to prevent module damage.**

Status Indicators. The front panel has six status indicators. The Triac Fail indicator lights when one of the output triacs has failed and caused the output fuse to open. The fuse-blown indicator lights when an output fuse has opened. The four output indicators show the ON/OFF state of outputs. The indicators provide field side indication of individual outputs.

ATTENTION: Do not configure the module so that 120V ac is fed back into the output of the module. Failure to observe this caution can result in damage to the module circuitry.

Connection Diagram

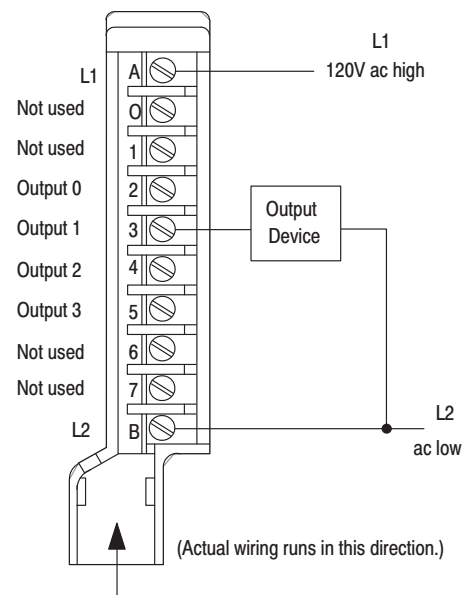

11891-1

Protected AC Output Module (Cat. No. 1771-OP)

Specifications (Cat. No. 1771-OP)

Outputs per Module	4	
Module Location	1771 I/O chassis	
Output Voltage Range	92 to 138V ac @ 47 – 63Hz	
Output Current Rating (maximum)	2A per output — not to exceed 6A per module	
Surge Current (maximum) per Output and Module	20A for 60ms, repeatable every 2 seconds	
Load Current (minimum)	80mA per output @ 120V ac, 60Hz	
On-State Voltage Drop (max.)	2V ac at 100mA	
Off-State Leakage Current (max.)	6mA per output @ 120V ac	
Signal Delay	Off to On	1.0ms
	On to Off	8.3ms at 60Hz
Power Dissipation	13.9 Watts (max.), 1.8 Watts (min.)	
Thermal Dissipation	47.2 BTU/hr (max.), 6.1 BTU/hr (min.)	
Backplane Current	350mA @ 5V dc ± 5%	
Isolation Voltage	Isolation meets or exceeds UL Standard 508, and CSA Standard C22.2 No. 142.	
Environmental Conditions		
Operational Temperature	0° to 60°C (32° to 140°F)	
Storage Temperature	-40° to 85°C (-40° to 185°F)	
Relative Humidity	5 to 95% without condensation	
Conductors	Wire Size	14 gauge (2mm ²) stranded maximum
	Category	3/64 inch (1.2mm) insulation maximum ¹
Keying	Between 6 and 8 Between 26 and 28	
Fuses	0.5A Bussmann GLD1/2 5A Bussmann 250V Normal Littelfuse 312005 5A	
Field Wiring Arm	Catalog Number 1771-WA	
Wiring Arm Screw Torque	7-9 inch-pounds	
Agency Certification (when product or packaging is marked)	<ul style="list-style-type: none"> • CSA certified • CSA Class I, Division 2, Groups A, B, C, D certified • UL listed • CE marked for all applicable directives 	
Installation Instructions	1771-2.23	

¹ You use this conductor-category information for planning conductor routing as described in the system-level installation manual.

Status Indicators

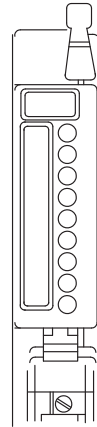

Triac Fail
Fuse Blown
Output 0
Output 1
Output 2
Output 3
Not used
Not used

Note: The Triac Fail indicator illuminates when one of the output triacs has shorted and caused the output fuse to open. If the light is on, the module should be returned to Allen-Bradley for repair.

11893-I

Sample Connection Diagram - Driving a 1771-IA Module with a 1771-OP Module

Protected AC (120V) Output Module Cat. No. 1771-OP AC (120V) Input Module Cat. No. 1771-IA

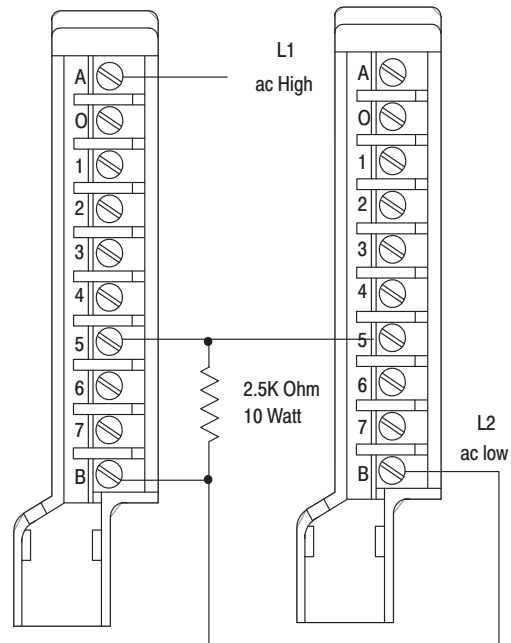

11892-I

Isolated AC Output Module (Cat. No. 1771-OR Series B)

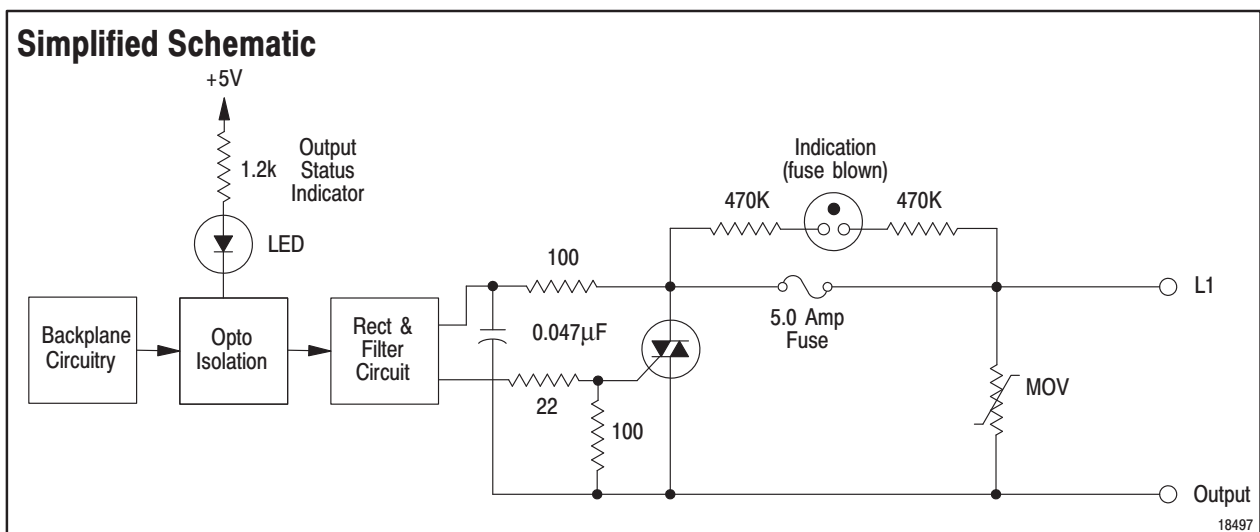

Application Notes

Device Compatibility. An output from this module can drive an Allen-Bradley size 5 motor starter provided its supply voltage does not drop below 184V ac.

Minimum/ Maximum Load Current. The maximum load current the module can handle is 2A per output not to exceed 6A per module. The triac needs a minimum load current of 60mA to stay on.

Connection to Input Modules. You can use an isolated ac (220V) output module (cat. no.1771-OR) to directly drive terminals on an ac input module (cat. no. 1771-IM or -IMD). However, you must connect a 3.3K ohm, 20W resistor between the output terminal and L2 (common).

Status Indicators. The front panel has 12 status indicators. The top six indicators show the state of each output and are driven by the logic circuitry on the controller side of the module. An indicator lights when the corresponding output is energized. The bottom six indicators indicate a fuse-blown condition at the respective output.

Connection Diagram

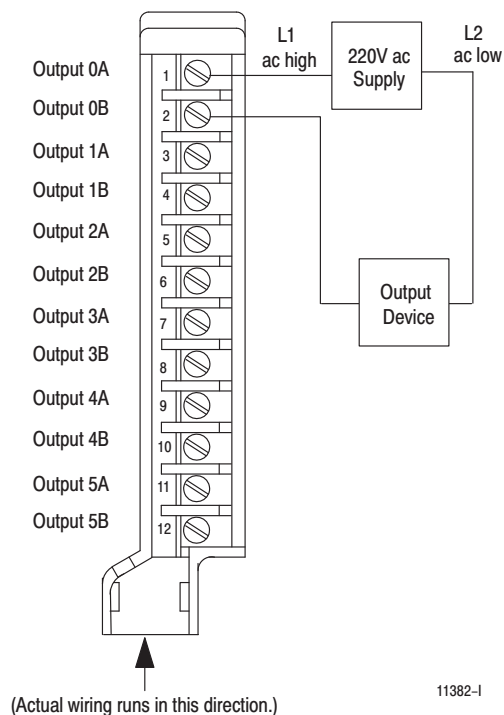

11382-1

Isolated AC Output Module (Cat. No. 1771-OR Series B)

Specifications (Cat. No. 1771-OR/B)

Outputs per Module	6	
Module Location	1771 I/O chassis	
Nominal Output Voltage	220V ac, 50/60Hz	
Output Voltage Range	184 to 276V ac @ 47 - 63Hz	
Output Current Rating	2A per output - not to exceed 6A per module	
Surge Current (maximum) per Output and Module	15A for 100ms, repeatable every 2 seconds	
Load Current (minimum)	60mA per output @ 220V ac, 60Hz	
On-state Voltage Drop (max.)	2V at 100mA	
On-state Leakage Current (max.)	10mA per output @ 276V ac	
Signal Delay	Off to On	1.0ms
	On to Off	8.3ms @ 60Hz
Power Dissipation	13.2 Watts (max.), 1.2 Watts (min.)	
Thermal Dissipation	45.1 BTU/hr (max.), 4.1 BTU/hr (min.)	
Backplane Current	255mA @ 5V dc ± 5%	
Isolation Voltage	Isolation meets or exceeds UL Standard 508, and CSA Standard C22.2 No. 142.	
Environmental Conditions		
Operational Temperature	0° to 60°C (32° to 140°F)	
Storage Temperature	-40° to 85°C (-40° to 185°F)	
Relative Humidity	5 to 95% (without condensation)	
Conductors	Wire Size	14 gauge (2mm ²) stranded maximum 3/64 inch (1.2mm) insulation maximum
	Category	1 ¹
Keying	Between 4 and 6 Between 30 and 32 Between 34 and 36	
Fuse	5A, 250V 3AG Normal Blow (1 per output) Littelfuse 312005 Bussman Fuse AGC-5	
Field Wiring Arm	Catalog Number 1771-WD	
Wiring Arm Screw Torque	7-9 inch-pounds	
Agency Certification (when product or packaging is marked)	<ul style="list-style-type: none"> • CSA certified • CSA Class I, Division 2, Groups A, B, C, D certified • UL listed • CE marked for all applicable directives 	
Installation Instructions	1771-2.40	

¹ You use this conductor-category information for planning conductor routing as described in the system-level installation manual.

Status Indicators

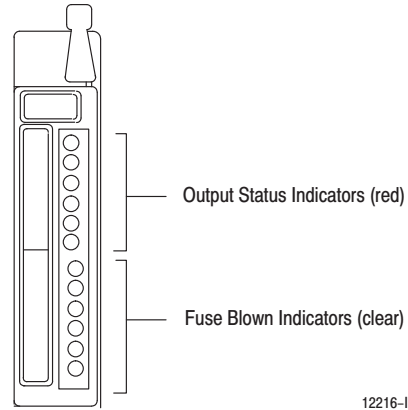

Sample Connection Diagram - Driving a 1771-IM Module with a 1771-OR Module

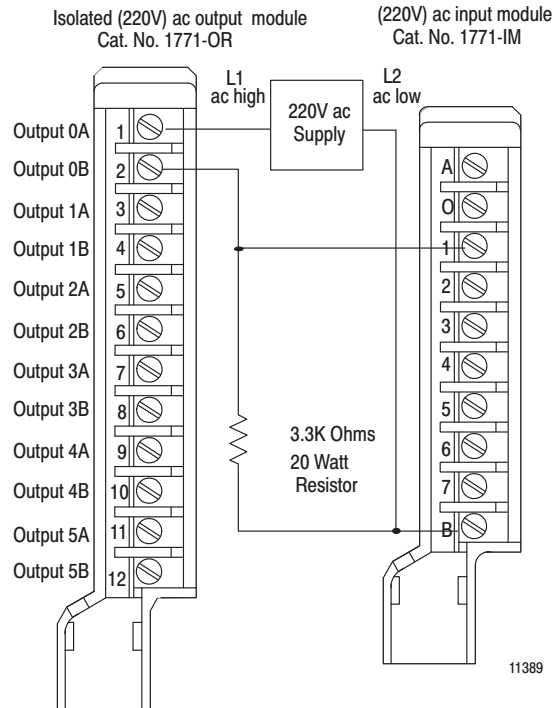

11389

Notes

Notes

Support Services

At Allen-Bradley, customer service means experienced representatives at Customer Support Centers in key cities throughout the world for sales service and support. Our value-added services include:

Technical Support

- SupportPlus programs
- telephone support and 24-hour emergency hotline
- software and documentation updates
- technical subscription services

Engineering and Field Services

- application engineering assistance
- integration and start-up assistance
- field service
- maintenance support

Technical Training

- lecture and lab courses
- self-paced computer and video-based training
- job aids and workstations
- training needs analysis

Repair and Exchange Services

- your only “authorized” source
- current revisions and enhancements
- worldwide exchange inventory
- local support



Allen-Bradley, a Rockwell Automation Business, has been helping its customers improve productivity and quality for more than 90 years. We design, manufacture and support a broad range of automation products worldwide. They include logic processors, power and motion control devices, operator interfaces, sensors and a variety of software. Rockwell is one of the world's leading technology companies.



Worldwide representation.

Argentina • Australia • Austria • Bahrain • Belgium • Brazil • Bulgaria • Canada • Chile • China, PRC • Colombia • Costa Rica • Croatia • Cyprus • Czech Republic • Denmark • Ecuador • Egypt • El Salvador • Finland • France • Germany • Greece • Guatemala • Honduras • Hong Kong • Hungary • Iceland • India • Indonesia • Ireland • Israel • Italy • Jamaica • Japan • Jordan • Korea • Kuwait • Lebanon • Malaysia • Mexico • Netherlands • New Zealand • Norway • Pakistan • Peru • Philippines • Poland • Portugal • Puerto Rico • Qatar • Romania • Russia-CIS • Saudi Arabia • Singapore • Slovakia • Slovenia • South Africa, Republic • Spain • Sweden • Switzerland • Taiwan • Thailand • Turkey • United Arab Emirates • United Kingdom • United States • Uruguay • Venezuela • Yugoslavia

Allen-Bradley Headquarters, 1201 South Second Street, Milwaukee, WI 53204 USA, Tel: (1) 414 382-2000 Fax: (1) 414 382-4444