

Chapter 8

16 Circuit DC Input/Output Blocks

Four different types of 16-Circuit DC I/O Blocks are available. There are two source blocks, which provide current to field output devices:

- **24 VDC Source block (IC660BBD022)**, for use with 2-wire and 3-wire solid state sensors and electromechanical sensors.
- **24/48 VDC Source block (IC660BBD020)**, for use with 3-wire solid state sensors and electromechanical sensors.

There are also two sink blocks, which receive current from field output devices:

- **24 VDC Sink block (IC660BBD023)**, for use with 2-wire and 3-wire solid state sensors and electromechanical sensors.
- **24/48 VDC Sink block (IC660BBD021)**, for use with 3-wire solid state sensors and electromechanical sensors.

Features

Genius 16 Circuit DC Input/Output blocks have 16 discrete circuits, each easily configured to be an input, tristate input, or output. Output circuits can be connected directly to input circuits without the use of other components or inversion of logic states.

Control power is tapped off the input/output device voltages wired to the terminals. No separate block power supply is needed.

Configurable features include:

- Output Pulse Test capability
- Selectable Input Filter Time from 10mS to 100mS
- Output power up defaults
- Output Hold Last State or default
- CPU Redundancy type
- Bus Switching Module control

The block's advanced diagnostics can pinpoint causes of installation and run-time errors. Each circuit has electronic circuit protection that shuts down an output if inductive surge current exceeds 15 amps for more than 10mS. The output is easily restored by command from a Hand-held Monitor or the CPU.

Additional diagnostics of these blocks are:

- Overtemperature Failed Switch
- Open Wire for Tristate Inputs
- Overload Detection and Shutdown
- No-load Detection

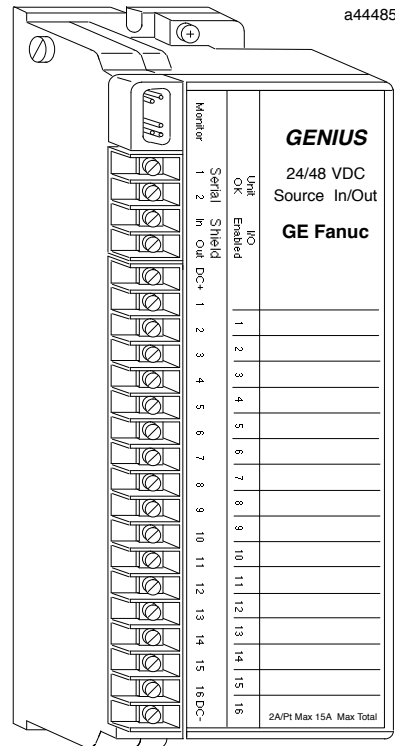

Compatibility

These blocks can be used with any Genius bus controller. They can also be used with a PCIM or QBIM module. They are compatible with all Genius Hand-held Monitors.

Specifications

Block Type: Catalog Numbers: 24/48VDC 16 Circuit Source I/O Block Terminal Assembly only Electronics Assembly only 24VDC Source 16 Circuit Source I/O Block Terminal Assembly only Electronics Assembly only 24/48VDC 16 Circuit Sink I/O Block Terminal Assembly only Electronics Assembly only 24VDC 16 Circuit Sink I/O Block Terminal Assembly only Electronics Assembly only	16 circuit discrete input and output IC660BBD020 IC660TSD020 IC660EBD020 (same as block IC660BBD022) IC660BBD022 IC660TBD022 IC660EBD020 (same as block IC660BBS020) IC660BBD021 IC660TSD021 IC660EBD021 (same as block IC660BBD023) IC660BBD023 IC660TBD023 IC660EBD021 (same as block IC660BBD021)																											
Size (height x width x depth): Weight: LEDS (block): LEDS (each circuit): Heat Dissipation: Block to Block Isolation:	8.83" (22.44cm) x 3.50" (8.89cm) x 3.94" (10.00cm) 4 lbs. (1.8 kg) Unit OK, I/O Enabled Individual load side indicators 68.8 Watts with 16 outputs on at 2 amps. 1500 V																											
Operating voltage: Ripple (maximum): Required DC power: Power supply dropout time:	18–56 VDC (24/48 V), 18–30 VDC (24 V) 10% 150mA typical / 300mA maximum 10mS																											
Input Characteristics: For standard input, voltage relative to (DC-)	<table border="0"> <thead> <tr> <th></th> <th style="text-align: center;">Source Blocks</th> <th style="text-align: center;">Sink Blocks</th> </tr> </thead> <tbody> <tr> <td>Input ON, 24 VDC supply</td> <td>16–24 VDC</td> <td>0–8 VDC</td> </tr> <tr> <td> 48 VDC supply*</td> <td>32–48 VDC *</td> <td>0–16 VDC*</td> </tr> <tr> <td>Input OFF, 24 VDC supply</td> <td>0–7 VDC</td> <td>17–24 VDC</td> </tr> <tr> <td> 48 VDC supply*</td> <td>0–14 VDC*</td> <td>34–48 VDC*</td> </tr> <tr> <td>Input processing time (typical)</td> <td colspan="2">5.6K ohms (24/48V), 1.8K ohms (24V)</td> </tr> <tr> <td>Input impedance (typical)</td> <td colspan="2">1.7mS (plus selectable filter delay)</td> </tr> <tr> <td>Selectable input filter times</td> <td colspan="2">5–100mS</td> </tr> <tr> <td>Input diagnostics</td> <td colspan="2">Open wire, Overtemperature, Failed Switch</td> </tr> </tbody> </table>		Source Blocks	Sink Blocks	Input ON, 24 VDC supply	16–24 VDC	0–8 VDC	48 VDC supply*	32–48 VDC *	0–16 VDC*	Input OFF, 24 VDC supply	0–7 VDC	17–24 VDC	48 VDC supply*	0–14 VDC*	34–48 VDC*	Input processing time (typical)	5.6K ohms (24/48V), 1.8K ohms (24V)		Input impedance (typical)	1.7mS (plus selectable filter delay)		Selectable input filter times	5–100mS		Input diagnostics	Open wire, Overtemperature, Failed Switch	
	Source Blocks	Sink Blocks																										
Input ON, 24 VDC supply	16–24 VDC	0–8 VDC																										
48 VDC supply*	32–48 VDC *	0–16 VDC*																										
Input OFF, 24 VDC supply	0–7 VDC	17–24 VDC																										
48 VDC supply*	0–14 VDC*	34–48 VDC*																										
Input processing time (typical)	5.6K ohms (24/48V), 1.8K ohms (24V)																											
Input impedance (typical)	1.7mS (plus selectable filter delay)																											
Selectable input filter times	5–100mS																											
Input diagnostics	Open wire, Overtemperature, Failed Switch																											
Output Characteristics: Output current (steady state) Maximum inrush current Block output current Output OFF leakage current Maximum switching frequency Output turn-on delay (maximum) Output voltage drop Minimum Recommended Load Output Diagnostics	2 amps per circuit 10 amps up to 10mS 15 amps at 35C 1.0mA Once per second (high inrush current) 1mS 2.0 volts maximum at 2 amps inrush 50 mA with No Load nabled Short Circuit, Overload, No Load, Failed Switch, Overtemperature																											
Environmental: Operating temperature Storage temperature Humidity Vibration	0 to +60C (32 to +140F) –40 to +100C (–40 to +212F) 5 to 95% (non-condensing) 5–10Hz 0.2" (5.08mm) displacement, 10–200Hz at 1G																											

* for 24/48VDC blocks

Block Operation

Each circuit can be configured as an input, a tristate input, or an output. If the block is configured as a combination block, output feedback is provided via the corresponding input references.

16 Circuit DC Source I/O Blocks

A DC source block has all output devices connected to the negative (-) side of the power supply. Inputs control the positive (+) side.

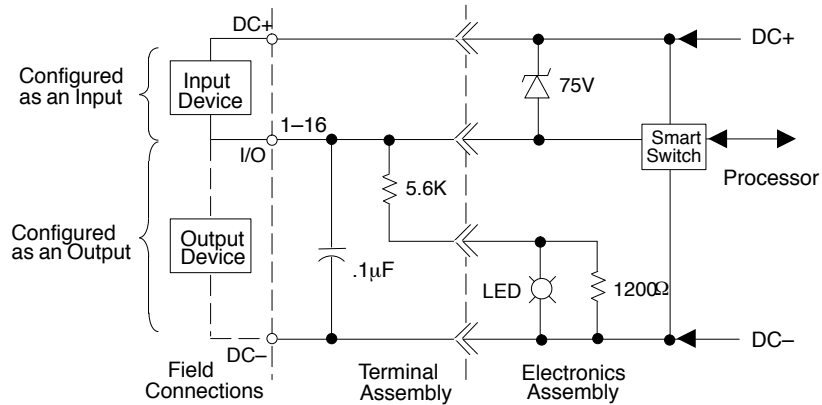

16 Circuit DC Sink Blocks

A DC sink block has all output devices externally connected to the positive (+) side of the power supply. Inputs control the negative (-) side.

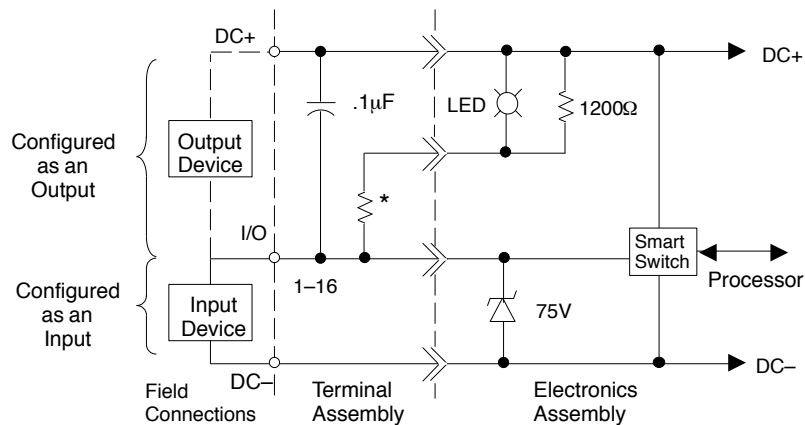

* 5.6K ohms for 24/48 VDC blocks.
1.8K ohms for 24 VDC blocks

For 24/48 Volt DC Blocks, the internal resistor is 5.6K ohms. For 24 Volt DC blocks, the internal resistor is 1.8K ohms.

Circuit LEDs

Each circuit has its own LED. If the circuit is configured as an input, the LED indicates the presence of threshold voltage at the input terminal. If the circuit is configured as an output, the LED indicates the actual state of the load.

Inputs and Outputs

The block can be configured as an inputs-only, outputs-only, or combination block. Regardless, the block always broadcasts two bytes of data each bus scan, and accepts two bytes of data each bus scan.

If the block is configured as an inputs-only block, all circuits must be regular inputs or tristate inputs. The block will use 16 input references and NO output references.

If the block is configured as an outputs-only block, all circuits must be regular outputs; no feedback analysis will be performed. The block will use 16 output references and NO input references.

If the block is configured as a combination block circuits can be any mix of inputs and/or outputs. The block will use 16 input references and 16 output references. The actual state of each output circuit will be returned to the CPU in the corresponding input references location. The CPU can monitor the feedback state to verify (after an appropriate delay) that the output switching device has operated properly and that the load has the proper voltage and current applied.

Appendix B shows reference usage for a Series 90, Series Six, or Series Five PLC.

Input Data Format

A 16 Circuit DC I/O Block broadcasts 2 bytes of input data each bus scan.

Byte #	Description
0	Inputs 1 – 8 (input 1 in bit 0)
1	Inputs 9 – 16 (input 9 in bit 0)

Output Data Format

The block receives 2 bytes of output data from the bus controller each bus scan.

Byte #	Description
0	Outputs 1 – 8 (output 1 in bit 0)
1	Outputs 9 – 16 (output 9 in bit 0)

Hand-held Monitor I/O Display

The Hand-held Monitor displays the I/O types (line 3) and current states (line 4) of all circuits on the Monitor Block screen.

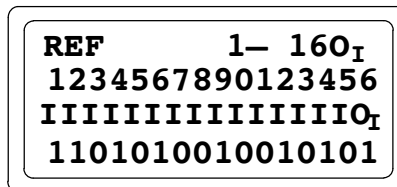

Individual circuits are displayed on the Monitor/Control Reference screen (which also shows a circuit's fault and force status).

Diagnostics

The block always performs its standard diagnostic checks, plus two optional output diagnostics. The block reports all faults to the Hand-held Monitor, and takes appropriate corrective action.

Individual circuits can be configured not to send diagnostic messages to the CPU if a fault occurs. If the CPU requests diagnostic information from the block using Read Diagnostics datagrams, the block returns current diagnostics for all circuits, including any with CPU fault reporting disabled.

Overtemperature Diagnostic

Each circuit has a built-in thermal sensor. If the block's internal temperature exceeds 100C, the block sends an OVERTEMPERATURE message and turns off the circuit to protect its internal electronics. This diagnostic is always performed for both inputs and outputs.

Short Circuit Diagnostic

Automatic output diagnostic. Output circuits are protected by a short circuit level sensor at the switching device. If the instantaneous current on an output exceeds 10 amps at turn-on, the block turns the output off within microseconds. The block will try to restart the load; if two attempts are unsuccessful, the output circuit is forced off and the block sends a SHORT CIRCUIT message. To restore normal operation to output the cause of the current surge must be removed, then the diagnostic must be cleared from the HHM or the CPU.

This diagnostic detects shorts across the load only. Also, systems with floating power supplies do not detect shorts of I/O points to ground because there is no return current path. Systems with power supplies grounded on the negative side detect grounded output points either as Failed Switch (sink blocks) or Short Circuit (source blocks).

Partial (high resistance) shorts may not draw enough current during a Pulse Test to be detected by the Pulse Test.

Failed Switch Diagnostic

The block automatically monitors all circuits for several types of faults, which may be reported as Failed Switch diagnostics.

For an output, Failed Switch is reported if the circuit's switch state is not the same as its commanded state. The block sends a FAILED SWITCH message identifying the failed circuit. The logic state of the circuit is set to OFF.

When an output fault occurs, the actual condition of the output switch is not known. If the output switch has failed shorted (or closed), current flow is not interrupted when the block forces the output state OFF. Action external to the block must be taken to remedy the problem. The FAILED SWITCH message can alert personnel or cause program logic to be activated, possibly shutting off power to the block, I/O section, or process.

Several additional switch faults independent of the output state are detected and reported as Failed Switch faults on both input and output-configured circuits. Examples include loss of communications with the block's internal microprocessor and some internal power supply faults.

Open Wire Diagnostic

The block automatically performs this diagnostic on any circuit configured as a tristate input. It will detect an electrical (not mechanical) malfunction in a circuit. In addition to being configured as a tristate input, the circuit must have a non-inductive resistor placed as close as practical to the actual dry contacts (such as across the field device terminals). For the 24/48 VDC blocks (IC660BBD020 and 021), a 5.1K ohm external resistor should be used. For the 24 VDC blocks (IC660BBD022 and 023), a 1.6K ohm external resistor should be used.

DC Source Block Tristate Input Thresholds

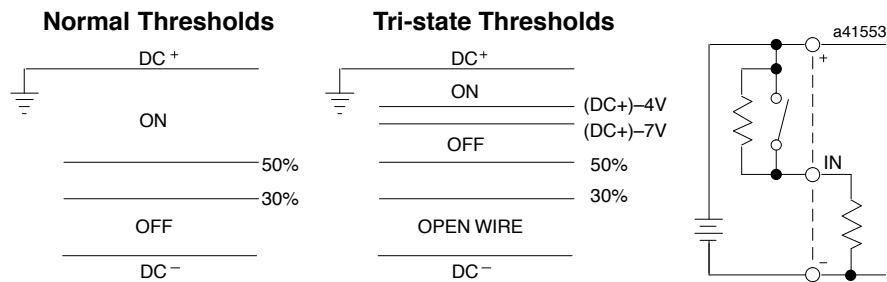

DC Sink Block Tristate Input Thresholds

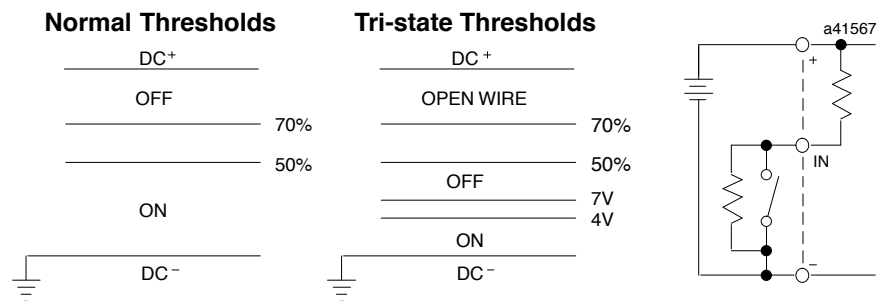

With the switch closed (ON state), the circuit senses the low source impedance. With the switch open (OFF state), the circuit senses the added resistance. If a wire is broken, cut or removed, impedance becomes very high. The block will transmit 0 as the state of the input, and send an OPEN WIRE message.

Since faulty input circuit monitoring requires specific current flows, devices as photo-sensors, electronic high-speed counters, instrumentation, fiber optic sensors, and similar electronic devices cannot be monitored for Open Wire conditions. Such devices should be set up as standard, not tristate, inputs.

GE offers compatible input devices including a 5.1K ohm monitoring resistor with its line of General Purpose Control sensor devices.

No Load Diagnostic

The optional No Load diagnostic can be enabled or disabled for individual outputs.

For a new block, outputs are configured to report No-Load conditions. In this configuration, energizing the output activates a no-load current level. If the load does not continuously draw 50mA from the output circuit, the block sends a NO LOAD message. Because this diagnostic monitors both current and voltage, a No Load condition may cause an HHM monitoring the block to display 0 for the circuit although there is voltage at the output and the circuit LED is on.

This diagnostic should not be used for circuits on which very small loads (small relays, transformers, or indicating lamps) will draw less than 50 mA.

Overload Diagnostic

Like No-Load detection, this diagnostic is optional for individual outputs on the block.

In addition to the protection provided by the block's built-in Short Circuit detection, Overload Shutdown provides further protection for output loads, field wiring, and switching devices. If a load exceeds 2.8 amps DC continuously for 10mS, the block will turn the output off and send an OVERLOAD message if Overload Shutdown is enabled.

For a load that requires more than 2 amps DC, the output can be configured not to shut off at this level or send the OVERLOAD message. These restrictions apply:

1. Maximum load current: 5 amps DC
2. Maximum duty cycle: limit duty cycle so that: (load current) x (% ON) is less than 1.0 amp.
3. Maximum ON time: 1 minute
4. Maximum total current of all outputs ON at the same time is less than 16 amps.

For example, a maximum 5 amp load can be pulsed at a 20% duty cycle, or up to 1 minute ON and 9 minutes OFF. Higher repetition rates can be used if the duty cycle is maintained. The duty cycle derating to an average of 1 amp output current and the ON time limit are needed to avoid overheating due to increased power dissipation in the block at these high currents. Exceeding these limits may cause an overtemperature fault.

Field Wiring

All field wiring to this block are standard screw, clamp-type terminals which can be operated with a flat or phillips-head screwdriver. Each terminal accepts one AWG #12 or two AWG #14 wires. The minimum recommended wire size is AWG #22. The terminals can accommodate spade or ring terminals up to 0.27 inch (6.85 mm) in width with a minimum opening for a #6 screw, and up to 0.20 inch (5.1 mm) depth from the screw center to the back barrier.

Connect a DC power source to the DC+ terminal (5) and the return to the DC- terminal (22). Depending on the layout and current loads, positive and negative connections can be bussed and made by individual wires back to the block or power source.

Connections for a DC Sink Block

Any circuit can be an input or output. Connect one terminal of the device to the block (terminals 6-21). Connect outputs to DC+ and inputs to DC-.

DC Sink Block, Power Disconnects

Since block power is the same as circuit power, it is important to wire block power disconnects so that block power and input power will be removed *at the same time*.

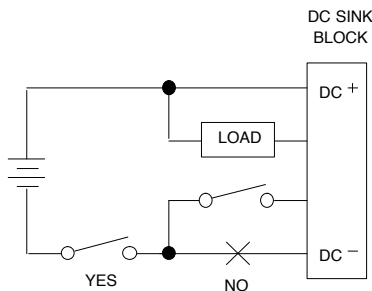

Caution

If circuit power is not removed at the same time as block power, the block may power up when multiple inputs are activated, even though one leg of power has been removed from the block.

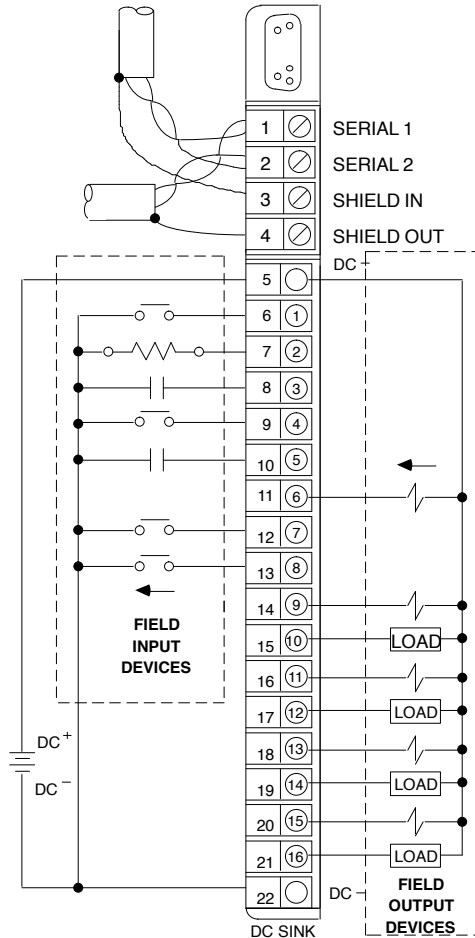

Sink Block, Wiring for Tristate Inputs

If any input is configured as a Tristate Input, install a resistor across the dry contacts of the input device. This added resistance is required to use the Open Wire diagnostic.

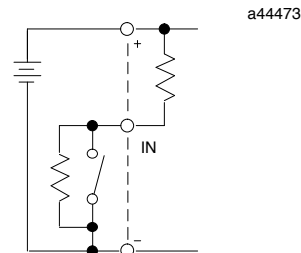

For a 24/48 VDC block, the resistor should be 5.1K ohms, 1/2 Watt or larger. For a 24 VDC block, the resistor should be 1.6K ohms.

Connections for a DC Source Block

Any circuit can be an input or output. Connect one terminal of the device to the block (terminals 6–21). Connect outputs to DC– and inputs to DC+.

For a DC source block, connect outputs to the negative side of the power supply and inputs to the positive side. No logic inversion is needed.

a41552

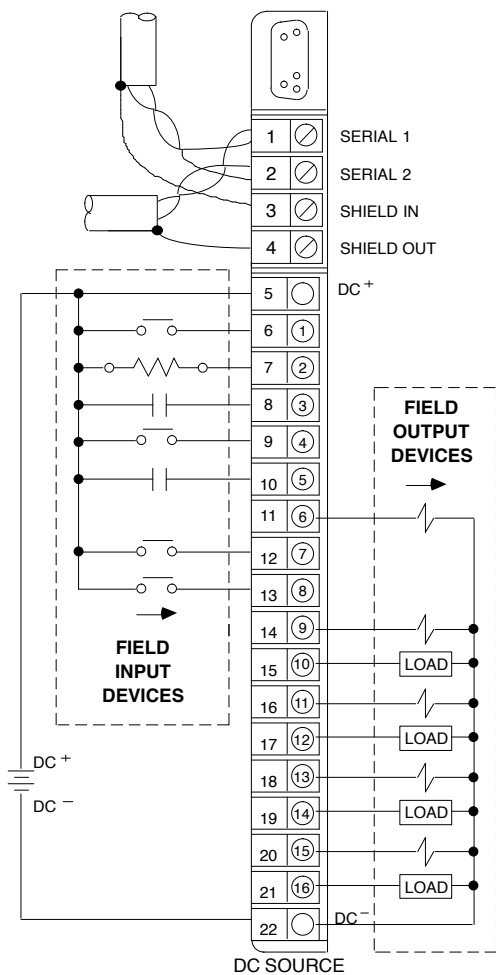

DC Source Block, Power Disconnects

Since block power is the same as circuit power, it is important to wire block power disconnects so that block power and input power will be removed *at the same time*. Locate the power disconnect as shown at right above.

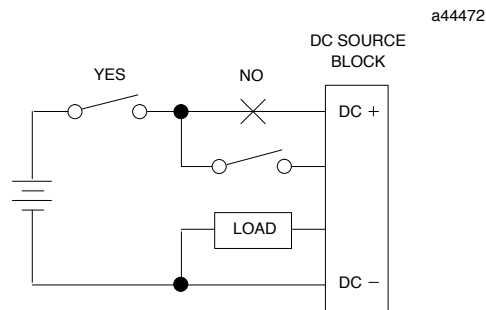

Caution

If circuit power is not removed at the same time as block power, the block may power up when multiple inputs are activated, even though one leg of power has been removed from the block.

Source Block, Wiring for Tristate Inputs

If any input is configured as a Tristate Input, install a resistor across the dry contacts of the input device. This added resistance is required to use the Open Wire diagnostic.

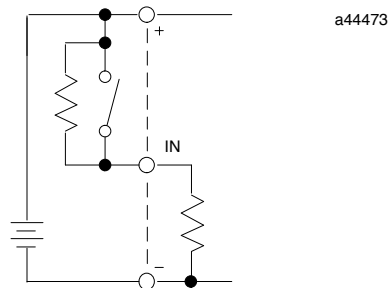

For a 24/48 VDC block, the resistor should be 5.1K ohms, 1/2 Watt or larger. For a 24 VDC block, the resistor should be 1.6K ohms.

Wiring for a Bus Switching Module

If the block will be a BSM Controller, attach the BSM like a load to circuit 1. Connect either BSM pigtail wire to terminal 6. For a DC Sink block, connect the other BSM wire to DC+. For a DC Source block, connect the other BSM wire to DC–.

Block Configuration

The configurable features of a 16 Circuit DC Input/Output Block are listed below. For many, the factory setting may not need to be changed.

Feature	Circuit or Block	Selections	Factory Setting
Device Number*	Block	null	0 to 31 (a number must be selected)
Reference Address*	Block	none	Depends on host CPU type
BlockI/OType*	Block	input	input, output, combination
Baud Rate*	Block	153.6std	153.6 std, 153.6 ext, 76.8, 38.4 Kbd
Pulse Test for Outputs	Block	enabled	enabled, disabled
Input Filter Time	Block	20mSec	10–100mSec in 10mS steps
CircuitI/OType	Circuit	input	input, output, tristate input
Report Faults	Circuit	yes	yes, no
Hold Last State	Circuit	no	yes, no
Output Default State	Circuit	off	on, off
Detect No Load	Circuit	yes	yes, no
Overload Shutdown	Circuit	yes	yes, no
BSM Present	Block	no	yes, no
BSM Controller	Block	no	yes, no
Output Default Time	Block	3 bus scans	(for bus redundancy) 2.5 or 10 sec
Redundancy Mode	Block	none	none, hot standby, duplex, GMR
Duplex Default	Block	off	on, off

Features marked with an asterisk in the table are configured from the Program Block ID screen of the Hand-held Monitor, as explained in chapter 3.

The rest of the features can be configured either using a Hand-held Monitor, or by sending a Write Configuration datagram to the block from the host.

Before configuration begins, the feature of each 16 Circuit DC Input/Output Block should be decided upon, then recorded on copies of the Configuration Worksheet printed on the next page.

16 Circuit DC I/O Blocks Configuration Worksheet

Block _____ Location _____

Block Features:

Configuration Protected (Y/N) _____

Block Number (0–31) _____ Block Type (Input/Output/Combination) _____

Reference Address _____ through _____

Baud Rate (153.6 Kb Std/153.6 Kb Ext/76.8 Kb/38.4 Kb) _____

Pulse Test (Enabled/Disabled) _____ Input Filter Time (5–100) mS _____

Redundancy Features:

Redundancy Mode (None/Standby/Duplex, GMR) _____ Duplex Default (on/off) _____

BSM Present (Y/N) _____ BSM Controller (Y/N) _____ Outputs Default (2.5/10 sec) _____

Circuit Features:

Ckt #	Reference Number	I/O Type (I/O/I _T *)	Report Faults (yes/no)	(output) Hold Last State (yes/no)	(output) Default State (ON/OFF)	(output) Report No Load (yes/no)	(output) Overload Shutdown (yes/no)
1	_____	_____	_____	_____	_____	_____	_____
2	_____	_____	_____	_____	_____	_____	_____
3	_____	_____	_____	_____	_____	_____	_____
4	_____	_____	_____	_____	_____	_____	_____
5	_____	_____	_____	_____	_____	_____	_____
6	_____	_____	_____	_____	_____	_____	_____
7	_____	_____	_____	_____	_____	_____	_____
8	_____	_____	_____	_____	_____	_____	_____
9	_____	_____	_____	_____	_____	_____	_____
10	_____	_____	_____	_____	_____	_____	_____
11	_____	_____	_____	_____	_____	_____	_____
12	_____	_____	_____	_____	_____	_____	_____
13	_____	_____	_____	_____	_____	_____	_____
14	_____	_____	_____	_____	_____	_____	_____
15	_____	_____	_____	_____	_____	_____	_____
16	_____	_____	_____	_____	_____	_____	_____

* I_T (Tristate Input) must have 5.1K Ω resistor across dry contacts of input device

Pulse Test

Pulse Testing verifies the ability of a block's outputs to change state. A new block is configured to enable Pulse Testing. Pulse Testing should remain enabled if the block has loads that hold one state for long periods of time, *unless any load(s) are sensitive to pulses or interruptions of up to 16mS*. It should be disabled if the block's loads will normally change state as the program executes. These will report faults during normal operation, and do not need to be pulsed.

Hand-held Monitor Configuration Steps

```
PULSE TEST
REF
ENABLED
  tgl entr nxt
```

1. To change the current selection, press F2 (tgl). Press F3 (enter).
2. Press F4 (next) to advance to the next configuration display.

Pulse Testing Outputs

Outputs can be pulse-tested from a Hand-held Monitor or by sending a command from the CPU. Pulse Testing checks the continuity of each output circuit including the switch device, power source, wiring, interposing devices (fuses, circuit breakers, terminals), and output device. It works whether or not there is minimum current to check for a No-Load condition. Pulse testing will not activate mechanical devices such as motor starters, relays, or solenoid valves.

Pulse Testing should momentarily cause outputs that are OFF to turn ON and outputs that are ON to go OFF. Progressively longer pulses are applied until the desired circuit function is sensed. If the pulse width reaches the maximum of 16mS without detecting valid operation, one of these fault conditions is reported:

Failed Switch: If the output does not change state when pulsed.

Short Circuit: If the load on an output that was OFF exceeds 10 amps when pulsed ON.

No Load: If the load on an output that was OFF draws less than 50 mA when pulsed ON.

If the output was OFF, no current flow when the output is pulsed indicates an open circuit or failed switch. Similarly, continued current flow when ON outputs are pulsed OFF indicates a shorted switch (both malfunctions are reported to the CPU).

Pulse Test Description

Pulse Testing switches a load to the opposite state then back again. This should occur so quickly that there is no effect on the mechanics or contact outputs of the load device.

Specific Pulse Test operation depends on whether or not No Load detection is enabled.

- A. If No Load detection is enabled, the block looks for presence or absence of load current, using the normal No Load threshold. This verifies load continuity.
- B. If No Load detection is NOT enabled, Pulse Testing tests only that the block output is switching voltage.

Pulse Testing begins with narrow pulses. If the appropriate condition described above is found on the first try, the test is complete. If the condition is not found, the test is repeated with successively longer pulses (2.5mS increments) until successful. The maximum Pulse Test time is 16 mS. If this time is reached and the result is still not successful, a fault message is generated.

The normal pulse width seen by the load is typically shorter than the maximum 16mS.

- A. With No Load detection enabled, the pulses required may be longer due to the rise time of the load current and the load inductance.

Power devices such as contactors and actuators will typically encounter maximum width pulses. Such devices draw moderate currents and are not affected by pulsing.

Low-power signal relays may have low current draw, high-inductance coils, and fast operation. Such devices may have to be examined closely.

- B. With No Load detection NOT enabled, a successful Pulse Test normally occurs in 4mS to 6mS. The time may be slightly longer if there are capacitive loads.

Suitable Loads for Pulse Testing

A resistive and/or inductive load is suitable for Pulse Testing if any of the following is true:

- A. If No Load detection is enabled:
 - 1. The minimum pickup current of the load is less than the No Load threshold of the block. The maximum threshold of the block is 50mA, but typical values are 20mA to 35mA.

When testing on-off-on operation, typical devices with rated currents of 75mA and up are suitable.

When testing off-on-off operation, certain devices may require the addition of a flyback diode directly across the load coil to increase the dropout time.
 - 2. The minimum pickup delay is greater than 16mS, and the dropout delay is greater than 5mS. Devices that have slow or delayed operation may be unsuitable because they will ride through the maximum width pulses.
 - 3. The rise time of current in the load, at normal voltage, allows the peak current to reach the threshold in less time than the device delay, as well as less than the 16mS maximum pulse width. The load current must reach 50mA before the contacts switch. If necessary, the load current can be increased by adding a resistor load across the coil, and the device end of the wiring. This will permit testing of wiring continuity, but it may not detect an open coil.
- B. If No Load detection is NOT enabled, the minimum pickup or dropout delay is greater than 5mS.

Input Filter Time

An input filter time of 5mS to 100mS can be selected for the block. The default filter time is 20mS.

The block continuously samples an input for the length of the filter time period. If the input remains either on or off for the length of the Filter Time, the block recognizes its state. For example:

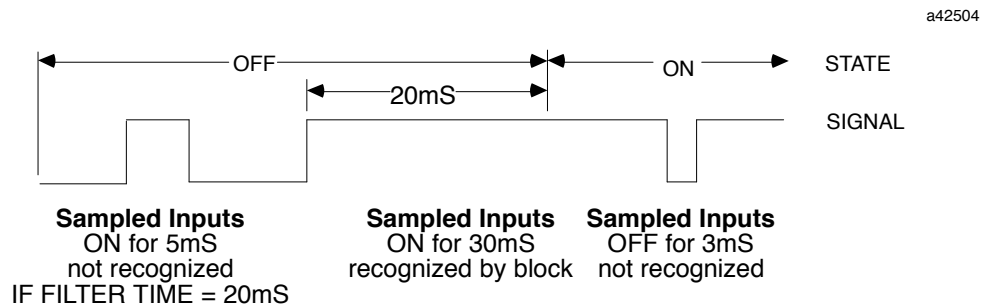

An input filter helps reject spurious noise spikes and multiple inputs generated by the bounce of mechanical devices. In controlled, noise-free environments, signals generated by clean, solid state electronics may be unnecessarily slowed by a filter, delaying system response. In such an environment, no additional filter time is needed.

In noisy environments, use a longer filter time to prevent noise from possibly causing erratic or unsafe system operations.

For a block with tristate inputs, the minimum recommended Input Filter Time is 50mS.

Hand-held Monitor Configuration Steps

```

INPUT FILTR TIME
REF
FILTER= 20mS
tgl entr nxt
  
```

1. The screen displays the currently-selected filter time. If this time should be changed, press F2 (tgl) to display the other filter times. To save a new selection, press F3 (entr).
2. Press F4 (next) to advance to the next configuration display.

I/O Circuit Type

An earlier configuration step selected the Block I/O type (on the Program Block ID screen). That step determined whether the block would be assigned all input references, all output references, or both. The default configuration for each circuit on the block is input. On the screen shown below, the I/O type of each circuit can be changed.

If the Block I/O Type selection was Input, each circuit can be either an regular input (I) or a tristate input (I_T). Select **Tristate Input** for any input circuit that should report the Open Wire diagnostic.

If the Block I/O Type is Output, each circuit must be an output (O).

If the Block I/O Type is Combination, each circuit can be configured as an input (I), an output (O), or a tristate input (I_T). Select **Tristate Input** for any input circuit that should report the Open Wire diagnostic.

Hand-held Monitor Configuration Steps

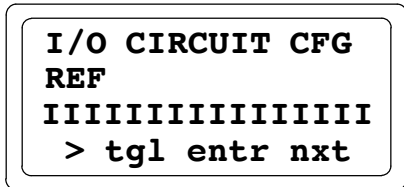

1. The screen displays the current I/O type of each circuit on the block. On this screen,
 I = the circuit is configured as an input.
 O = the circuit is configured as an output
 I_T = the circuit is configured as a tristate input
2. To select a circuit, press F1 (>). To change a selection, press F2 (tgl).
3. To save the new selection, press F3 (entr).
4. Press F4 (next) to advance to the next configuration display.

Report Faults to CPU

Fault reports to the host can be disabled or enabled for any circuit on a block.

If fault reporting is enabled for a circuit, the block will send a message to the host if any fault occurs on that circuit.

If fault reporting is disabled, the block will not send fault reports to the CPU for that circuit.

Regardless of whether fault *reporting* is enabled, the block will detect faults on the circuit, and take appropriate actions. The Unit OK LED will blink when a fault occurs, and a fault report is sent to a Hand-held Monitor. The fault condition must be corrected for proper operation of the block.

If the CPU requests diagnostic information from the block using Read Diagnostics datagrams, the block returns current diagnostics for all circuits, including any with CPU fault reporting disabled.

Hand-held Monitor Configuration Steps

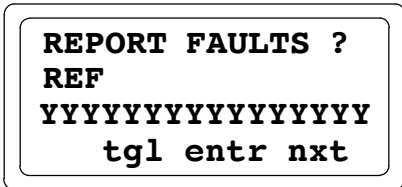

1. The screen displays the current Fault Reports selection for all circuits on the block. On this screen,
Y = report faults that occur on the circuit.
N = do not report faults
2. To select a circuit, press F1 (>).
3. To change the I/O type of the selected circuit, press F2 (tgl).
4. To save the new selection, press F3 (entr).
5. After configuring circuits, press F4 (next) to advance to the next configuration display.

Hold Last State

Each output can be independently configured to either hold its last state or to go to its powerup default state if the block loses CPU communications for at least 3 bus scans.

For a new block, Hold Last State is disabled for each output. With Hold Last State disabled, the block sets the output to its powerup default if CPU communications are lost.

If Hold Last State is enabled, the block continues to hold the output in its current state instead of setting it to the powerup default.

Outputs remain in their last state or default indefinitely or until one of the following occurs:

- Communications with the CPU are restored.
- The Hand-held Monitor changes the output by forcing it.
- Power is removed from the block.

Hand-held Monitor Configuration Steps

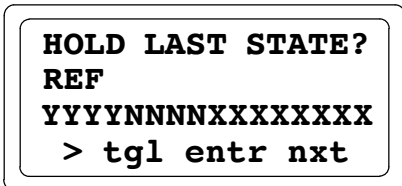

1. The screen displays the current Hold Last State configuration of all circuits. On this screen,
 - Y = hold last state.
 - N = go to default state (configured on the next HHM screen)
 - X = the circuit has been configured as an input.
2. To select a circuit, press F1 (>).
3. To change the selection for a circuit, press F2 (tgl).
4. To save the new selection, press F3 (entr).
5. Press F4 (next) when you are ready to advance to the next configuration display.

Output Default State

An output goes to its powerup default state when the block is first powered up.

If Hold Last State was NOT enabled, the block will also default the output if CPU communications are lost. On a non-redundant system, this occurs approximately 250mS after the third bus scan passes with no CPU communications. If the block is on a redundant bus downstream of a Bus Switching Module, more time is needed.

Hand-held Monitor Configuration Steps

```
OUTPUT DEFAULT
REF
000000111XXXXXX
> tgl entr nxt
```

1. The screen displays the Output Default state configuration of all circuits. On this screen,
0 = default is off.
1 = default is on.
X = the circuit has been configured as an input.
2. To select a circuit, press F1 (>).
3. To change the selection for a circuit, press F2 (tgl).
4. To save the new selection, press F3 (entr).
5. Press F4 (next) when you are ready to advance to the next configuration display.

Report No Load

By default, each output is configured to report No-Load diagnostics. Energizing the output activates a no-load current level. If the load does not continuously draw 50mA from the output circuit, the block sends a NO LOAD message.

Disable this diagnostic for any output where a very small load (small relay, transformer, or indicating lamp) will draw less than 50 mA.

Hand-held Monitor Configuration Steps

```
REPORT NO LOAD?
REF
YYYYYYNNXXXXXX
> tgl entr nxt
```

1. The screen displays the Report No Load configuration of all outputs. On this screen,
Y = the output will report No Load conditions.
N = the output will not report No Load conditions.
X = the circuit has been configured as an input.
2. To select a circuit, press F1 (>).
3. To change the selection for a circuit, press F2 (tgl).
4. To save the new selection, press F3 (entr).
5. Press F4 (next) when you are ready to advance to the next configuration display.

Overload Shutdown

Overload Shutdown protects output loads, field wiring, and switching devices. If a load exceeds 2.8 amps DC for 100mS and Overload Shutdown is enabled, the block turns the output off and sends an OVERLOAD message.

Under certain conditions (see page 8-7), Overload Shutdown detection and reporting can be disabled for output loads that require more than 2 amps RMS.

Hand-held Monitor Configuration Steps

```
OVRLOAD SHUTDWN?  
REF  
YYYN>NNNXXXXXXXXX  
> tgl entr nxt
```

1. The screen displays the Overload Shutdown configuration of all circuits. On this screen,
Y = overload will shut down output.
N = output will remain on.
X = the circuit has been configured as an input.
2. To select a circuit, press F1 (>).
3. To change the selection for a circuit, press F2 (tgl).
4. To save the new selection, press F3 (entr).
5. Press F4 (next) when you are ready to advance to the next configuration display.

BSM Present

If the block is connected to a single bus or to just one trunk of a dual bus, BSM Present should be set to NO.

Select YES if the block is located in a cluster connected to dual busses via a Bus Switching Module.

Hand-held Monitor Configuration Steps

```
BSM PRESENT ?  
REF  
STATUS = YES  
    tgl entr nxt
```

1. To change the BSM Present configuration, press F2 (tgl).
2. To save the new selection, press F3 (entr).
3. Press F4 (next) to advance to the next configuration display.

BSM Controller

A BSM Controller is a block to which a Bus Switching Module is directly attached, which controls the BSM's switching action. Selecting a block to be a BSM Controller block has no effect on the block's I/O type – the block can still be configured as an inputs-only block, but circuit #1 cannot be physically used as an input. The first circuit will not be under CPU control.

To change this configuration with a Hand-held Monitor, the block must first be configured for BSM PRESENT. The BSM CONTROLLER menu will not appear if BSM PRESENT is set to NO.

Hand-held Monitor Configuration Steps

```
BSM CONTROLLER?  
REF  
STATUS = NO  
    tgl entr nxt
```

1. To change the configuration, press F2 (tgl).
2. To save the new selection, press F3 (entr).
3. Press F4 (next) to advance to the next configuration display.

Output Default Time

When a Bus Switching Module is used, the Output Default Time must be long enough to allow the BSM to switch without causing outputs to default. Therefore, when BSM Present is selected (above), the block automatically changes its Output Default Time from 3 bus scans to 2.5 seconds.

If Hold Last State was selected, outputs will remain in their last state while the BSM Switches, instead of defaulting, so there is no need to change this selection.

If Hold Last State was set to NO for any output on a block, and total bus scan time will exceed 100mS, change this selection to 10 seconds.

Hand-held Monitor Configuration Steps

```

OUTPUT DEF.TIME
REF
TIME = 2.5 SECS
tgl entr nxt

```

1. To change the configuration, press F2 (tgl).
2. To save the new selection, press F3 (entr).
3. Press F4 (next) to advance to the next configuration display.

CPU Redundancy

The block can be configured for No Controller redundancy, Hot Standby or Duplex redundancy, or Genius Modular Redundancy (GMR). For new blocks, No Controller Redundancy is selected.

In Hot Standby mode, a block receives output data from both CPUs but uses the data from only one of them to drive its outputs. The block prefers outputs sent by the bus interface module (Bus Controller or PCIM) with Device Number 31. If those outputs are not available, the block will use outputs from the bus interface module with Device Number 30. If no outputs from a CPU are available, outputs will either Hold Last State or go to their defaults.

In Duplex redundancy mode, the block compares outputs received from two CPUs and sets any outputs for which there is disagreement to their Duplex Default state.

Select GMR mode only for blocks that will be part of a Genius Modular Redundancy system as described in the *GMR User's Manual*. **Do not try to configure a block for GMR mode without referring to the detailed configuration instructions in that book.**

Hand-held Monitor Configuration Steps

```

CPU REDUNDANCY
REF
NO CTRL REDUND
tgl entr nxt

```

1. To change the current selection, press F2 (tgl).
2. Press F3 (entr) to save the new selection.
3. Press F4 (next) to advance to the next configuration display.

Duplex Default State

In Duplex Redundancy mode, if the block receives different output states for given points, the block breaks the tie by outputting the Duplex Default State to those points. For new blocks, OFF is selected for all outputs. Change it if outputs should be ON.

Hand-held Monitor Configuration Steps

```
DUPLEX DEFAULT
REF
OFF
    tgl entr nxt
```

1. To change the Duplex Default state, press F2 (tgl). Press F3 (entr) to save the new selection.
2. Press F4 (next) to advance to the next configuration display.

Note

If the block loses communications with BOTH CPUs, individual outputs go to their configured Hold Last State or Output Default State.

Configuration Protection

This feature can be used to protect the block's configuration, preventing changes from the CPU or Hand-held Monitor. It can only be selected from the Hand-held Monitor. To make subsequent changes, protection must be removed again using the Hand-held Monitor. For a new block, configuration is unprotected. Before a block is used in the system, its configuration should be protected.

Hand-held Monitor Configuration Steps

```
CONFIG PROTECT
REF
DISABLED
    tgl entr nxt
```

1. To change the current selection, press F2 (tgl).
2. Press F3 (entr) to save the new selection.
3. Press F4 (next) to return to the first configuration display.