

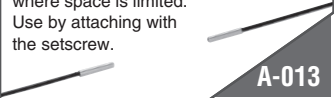







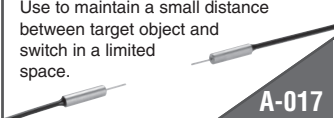
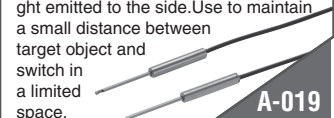

Fiber Units

HPF Series

Wide range of models for various applications and environments

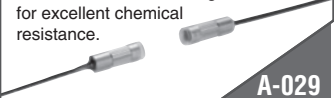
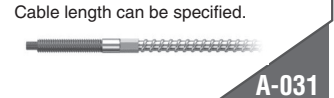
SEARCH BY TYPE OR APPLICATION

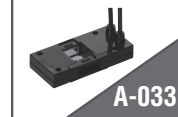
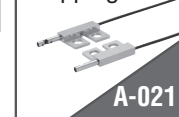
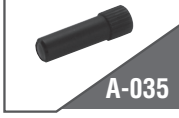
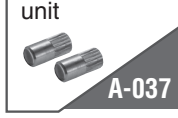
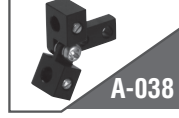
Select by shape or optical type	<p>Screw Most generally used. Use by attaching to a bracket, etc.</p>  <p>A-009</p>	<p>Cylindrical Suitable for installation where space is limited. Use by attaching with the setscrew.</p>  <p>A-013</p>	<p>Coaxial Used for target object positioning or in combination with spot lenses.</p>  <p>A-015</p>	
	<p>Sleeve Use to maintain a small distance between target object and switch in a limited space.</p>  <p>A-017</p>	<p>Side view Light emitted to the side. Use to maintain a small distance between target object and switch in a limited space.</p>  <p>A-019</p>	<p>Narrow view Light spread minimized. Use in a place where light intrusion is undesirable.</p>  <p>A-021</p>	
	<p>Flat/Vane Suitable for installation where space is limited. Attach directly to casing.</p>  <p>A-023</p>	<p>Selective reflection Resistant to ambient influences. Use for target object detection in a limited area.</p>  <p>A-024</p>	<p>Area Wide light beam. Use for target object with varying detection positions, detection of meandering, etc.</p>  <p>A-025</p>	
	Select by environment	<p>Heatproof Resistant to high temperatures. Use in environments up to 350 °C.</p>  <p>A-027</p>	<p>Chemical-proof Protected with PFA tubing for excellent chemical resistance.</p>  <p>A-029</p>	<p>Vacuum-proof Usable in a vacuum. Cable length can be specified.</p>  <p>A-031</p>
		Select by application	<p>Liquid level detection</p>  <p>A-034</p>	<p>Liquid level detection</p>  <p>A-033</p>
	<p>Passing chip detection</p>  <p>A-033</p>		<p>Wefer Mapping</p>  <p>A-021</p>	
Accessories	<p>Lens unit accessory</p>  <p>A-035</p>		<p>Long-distance lens / side view unit</p>  <p>A-037</p>	<p>Other accessories</p>  <p>A-038</p>

SEARCH BY MODEL NUMBER

Thru scan
(HPF-T□□□)

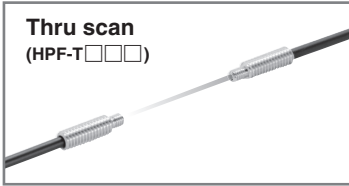

Diffuse scan
(HPF-D□□□)

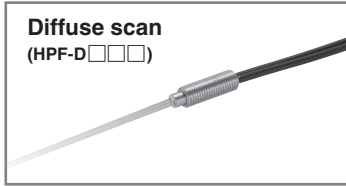

Lens unit accessory



Model No.	Page
HPF- T001	A-009
T002	A-013
T003	A-009
T004	A-013
T005	A-017
T006	A-017
T007	A-019
T008	A-009
T009	A-013
T010	A-009
T012	A-027
T014	A-027
T015	A-017
T017	A-027
T018	A-027
T019	A-021
T020	A-021
T021	A-025
T021T	A-025
T021S	A-025
T021WT	A-025
T023	A-021
T024	A-009
T025	A-009
T025B	A-009
T026	A-019
T028	A-023
T028LF	A-023
T029	A-029
T029E	A-029
T030	A-021,087
T031	A-013
T032	A-034,073
T032E	A-034,073
T032E-L02	A-034,073
T033	A-009
T034	A-034,073
T034E	A-034,073
T034E-L02	A-034,073
T035	A-029
T036	A-013
T037	A-019
T038	A-013
T039	A-017
T042	A-019
T043	A-013
T044	A-009
T046	A-013
T047	A-033,085
T054-L05	A-023
VT□□	A-031

Model No.	Page
HPF- D001	A-011
D002	A-011
D003	A-017
D004	A-011
D005	A-013
D006	A-017
D009	A-015
D010	A-015
D011	A-019
D012	A-011
D013	A-027
D014	A-029
D015	A-027
D018	A-011
D019	A-017
D021	A-017
D022	A-027
D023	A-027
D025	A-021
D026	A-025
D027	A-033,077
D028	A-024
D028F	A-024
D028T	A-024
D029	A-011
D030	A-011
D032	A-015
D032B	A-015
D033	A-033,077
D034	A-015
D035	A-015
D035C	A-015
D036	A-013
D037	A-011
D038	A-015
D039	A-017
D040	A-034,083
D041	A-019
D042	A-015
D043	A-019
D045LF	A-023
D049	A-015
VD□□	A-031

Model No.	Page
FE- PA-F1	A-038
PA-FB1	A-038
PA-FB2	A-038
PA-FB4	A-038
PA-L1	A-037
PA-S1	A-037
HPF- AT10	A-038
AT13	A-038
EU02A1	A-033,086
EU05	A-038
EU10	A-038
LU01	A-035
LU02	A-035
LU07	A-035
LU08	A-035
LU09	A-035
VA01	A-032
VA02-B	A-032
VJ03	A-032
VL05	A-032,037
VL06	A-032,037
HPX- PA06	A-038

●Introducing: Combination Amplifiers

High performance • Advanced functions

HPX-AG series

<Exterior view>



<Operation panel>



Typical models

Type	Model No.
Standard	HPX-AG00-1S
Space-saving(main unit)	HPX-AG00-3S
Space-saving(expansion unit)	HPX-AG00-5S

Double digital display
High-sensitivity, ultra-long distance detection Multifunctional models
(Alarm output, differential output, two outputs, databank, etc.)

<Standards compliance>



[▶ A-045 Page](#)

Volume

HPX-EG series

<Exterior view>



<Operation panel>



Typical models

Type	Model No.
Standard	HPX-AG00-1S
Space-saving(main unit)	HPX-AG00-3S
Space-saving(expansion unit)	HPX-AG00-5S

Double digital display
Built for usability
(Sensitivity auto-change function, threshold value tracking function)

<Standards compliance>



[▶ A-053 Page](#)

Standard

**HPX-A series
HPX-H series**

<Exterior view>



<Operation panel>



Typical models

Type	Model No.
Low hysteresis	HPX-A1
High sensitivity	HPX-H1

Sensitivity adjuster with indicator
Self-diagnostic display (output)
Slim 10 mm profile

<Standards compliance>



[▶ A-061 Page](#)

●Introducing: Fiber Customization Services

► Change the cable length

If fiber length is insufficient, you can specify a cable length.

<Example model number>

HPF-T001-L05

Base model number L02 : Fiber length 2 m
 L05 : Fiber length 5 m
 L10 : Fiber length 10 m

- Price: Determined by quantity
- Qty: No minimum (1 cable or more)

* For details on the scanning distances with a different cable length, see the Technical Guide (page A-039).
 * The cable cannot be lengthened on some models. For details, please contact our sales staff.

► Change the sleeve length

A range of on-site services are available, such as emergency switch additions and changes, and sample production evaluation.

■ Applicable models

Thru scan	Diffuse scan
HPF-T005	HPF-D003
HPF-T015	HPF-D006
HPF-T037	HPF-D011

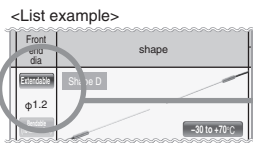

► A-017 / A-019 Page

Customizable models have this label.

■ Example model number

For an HPF-T005 with a 120 mm sleeve and 5 m fiber unit cable

HPF-T005-S120L05 is the model number.

The standard (base) model No. "S" + 3-digit sleeve length. Cable length. This can be omitted if length is standard.

- Price: Determined by quantity
- Quantity: No minimum (1 cable or more)

●Introducing: Element Types

Material of element

Plastic

Performance/Feature

General-purpose

Bend tolerant

Unbreakable

Heatproof

Multi-component glass

Heatproof Two types, 200°C and 350°C

Vacuum 350°C

<List example>

Cable			
Bend radius	Length	Amp	Element type
R1	2 m	HPX-AG	Indicates element type.
R1	2 m	HPX-EG	
R1	2 m	HPX-F	
R1	2 m	HPX-A	

■ Bend-tolerant fiber unit

R4

For use in moving environments



■ Cyclic bending test (reference)

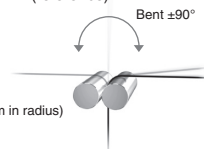

[Measurement conditions]
 Roller diameter: 8 mm (4 mm in radius)
 Load: 500 g

For example, HPF-T008 and -T009 withstand 1,000,000 bends under these conditions without breaking.

■ Unbreakable fiber unit (stationary bend type)

R1 / R2

Even if the cable is bent at a small radius, the light level does not change.

Thanks to multi-core structure bundling several 100s of fiber elements, bending the cable does not attenuate the light level.

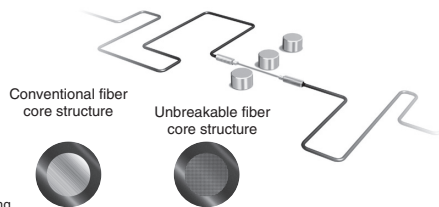

Applications

CASE STUDIES (WITH ACTUAL WORKPIECE DATA)

This section gives application case studies along with evaluation data using actual workpieces.

Liquid level detection

[Type] Specialized use (Thru scan)

[Catalog listing] **HPF-D027, HPF-D033**

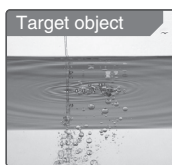
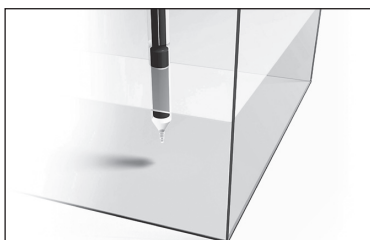

Water

Reference data Received light level display value

Combination amplifiers: HPX-EG series
(Sensing model : nL3)

Catalog listing	Presence of liquid	Absence of liquid
HPF-D027		
HPF-D033		

Liquid level detection ▶ A-077

Liquid level detection

[Type] Specialized use (Thru scan)

[Catalog listing] **HPF-T032_, HPF-T034_**

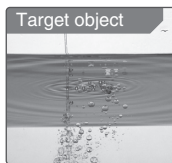

Water

Reference data Received light level display value

Combination amplifiers: HPX-AG series
(Sensing mode : nL3
For 8 mm dia. pipe only : nL2)

Catalog listing	Pipe diameter	Presence of liquid	Absence of liquid
HPF-T032 HPF-T032E	6 mm		
	8 mm		
HPF-T034 HPF-T034E	12 mm		
	19 mm		

Liquid level detection ▶ A-073

Liquid leak detection

[Type] Specialized use (Diffuse scan)

[Catalog listing] **HPF-D040**

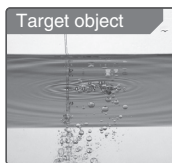
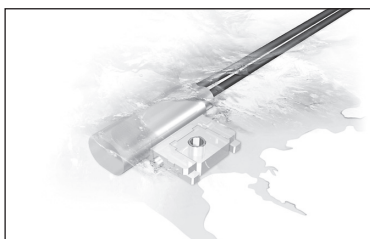

Water

Reference data Received light level display value

Combination amplifiers: HPX-EG series
(Sensing mode: nL3)

Catalog listing	Presence of liquid	Absence of liquid	Switch floating
HPF-D040			

Liquid leak detection ▶ A-083

Wafer mapping

[Type] Narrow view (Thru scan)

[Catalog listing] **HPF-T030**

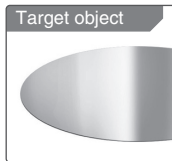
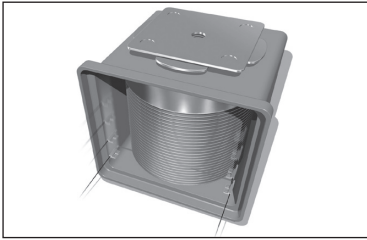

Silicon wafer (300 mm)

Reference data Light level change characteristics

Combination amplifiers: HPX-AG series
(Sensing model : HP3)

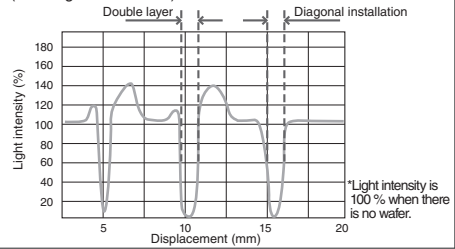

Narrow view ▶ A-087

Wafer projection detection

[Type] Narrow view (Thru scan)

[Catalog listing] **HPF-T020**

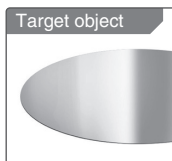
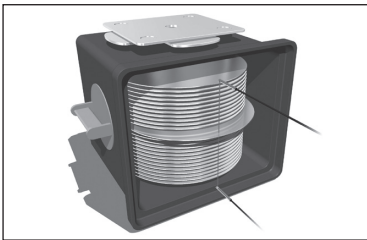

Silicon wafer (300 mm)

Reference data

Combination amplifiers: HPX-AG series
(Sensing model: HP3)

Item	Amount
σ	3 μm max.
Max - Min	11 μm

■ Edge detection repeatability accuracy

Narrow view ▶ A-021

Gold wire detection

[Type] Coaxial (Diffuse scan)

[Catalog listing] **HPF-D009**

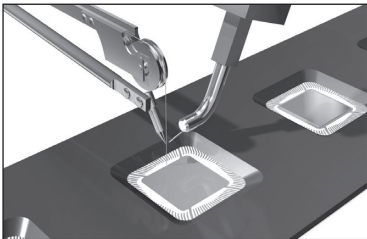

Gold wire ($\phi 17 \mu\text{m}$)

Reference data Detection area characteristics

Combination amplifiers: HPX-AG series
(Sensing model : HP, FT)

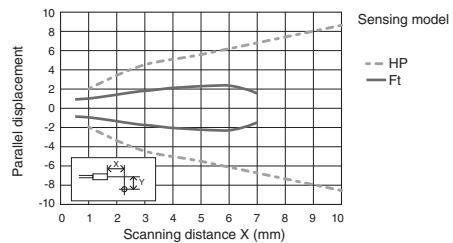

Coaxial ▶ A-015

Lead frame detection

[Type] Area (Diffuse scan)

[Catalog listing] **HPF-D026**

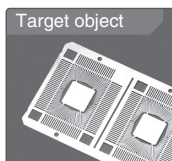
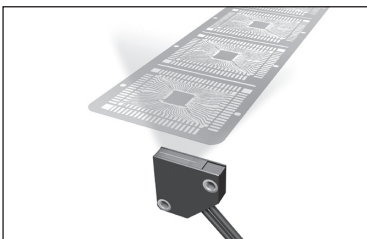

Lead frame size
35 mmx150 mm

Reference data Excess gain

Combination amplifiers: HPX-AG series
(Sensing model : HP3)

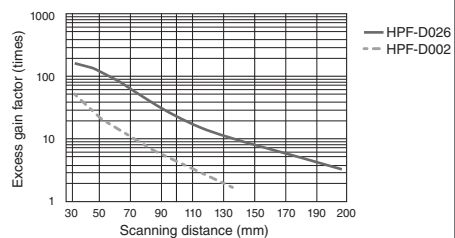

Area ▶ A-025

Note: The possibility of detection, as well as the measurement performance and degree of accuracy, are affected by the actual working conditions. Before using the fiber unit, carry out a careful operation check.

Passing chip detection

[Type] Specialized use (Thru scan)

[Catalog listing] **HPF-D027, HPF-D033**

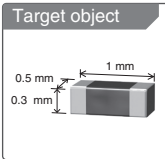
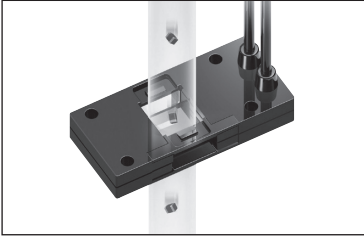

Target object size 1 mm x 0.5 mm
Thickness 0.3 mm

Reference data Light level change characteristics

Combination amplifiers: HPX-EG series (Sensing model : nL3)

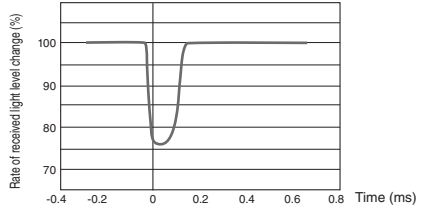

Notes: •The characteristic changes depending on the fall velocity and attitude of the chip.
•This chart shows data for when the adapter for a small-diameter pipe (HPF-AU04) is attached.

Passing chip detection ▶ A-015

Chip face/back discrimination

[Type] Coaxial (Diffuse scan)/ Micro-Spot Lens

[Catalog listing] **HPF-D034, HPF-LU07**

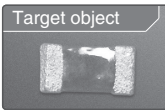
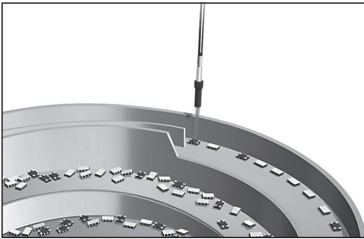

(Back)
Target size 1 mm x 0.5 mm

Reference data Received light level display value

Combination amplifiers: HPX-EG series (Sensing model : nL3)

Scanning distance	Front of component	Rear of component
-2 mm		
-1 mm		
Focal Distance		
+1 mm		
+2 mm		

Coaxial/Micro-Spot Lens ▶ A-015
A-035

Substrate "Bad" mark detection

[Type] Coaxial (Diffuse scan) / Micro-Spot Lens

[Catalog listing] **HPF-D038, HPF-LU08**

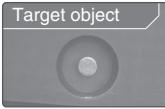
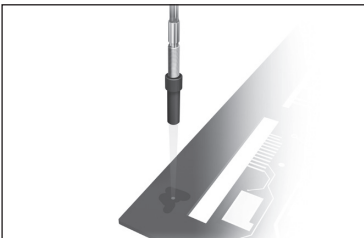

Gold pattern
Approx. 1 mm dia.

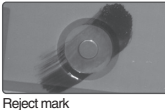

Reject mark
*The reject mark is applied to the gold pattern using an oil-based red felt pen.

Reference data Received light level display value

Combination amplifiers: HPX-AG series (Sensing model : Ft3)

Scanning distance	Mark	Reject mark
-2 mm		
-1 mm		
Focal Distance		
+1 mm		
+2 mm		

Coaxial/Micro-Spot Lens ▶ A-015
A-035

Detection of meandering

[Type] Area (Thru scan)

[Catalog listing] **HPF-T021T** □

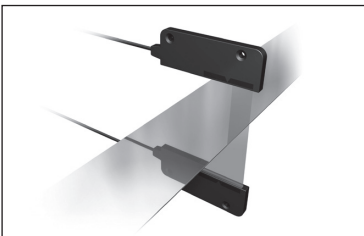

Opaque Sheet

Reference data Light level change characteristics

Combination amplifiers: HPX-MA series
(SENS:FINE RESP:NORMAL)

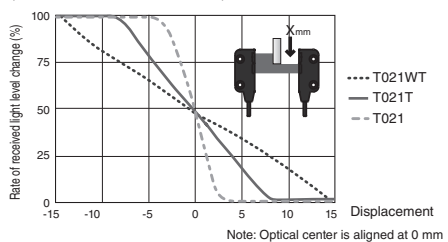

Note: Optical center is aligned at 0 mm

Area ▶ A-025

Glass detection

[Type] General-purpose screw (Diffuse scan)

[Catalog listing] Fiber: **HPF-D002** Amplifiers: **HPX-AG** series (HP3)

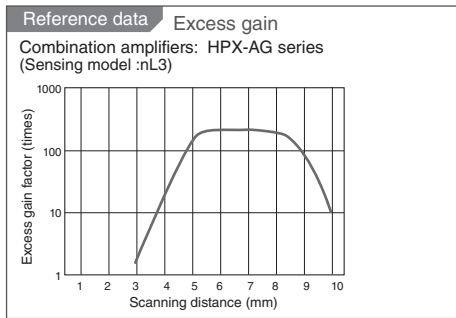
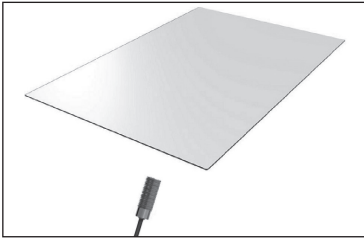

Screw ▶ A-011

Glass detection

[Type] Selective reflection (Diffuse scan)

[Catalog listing] **HPF-D028T**

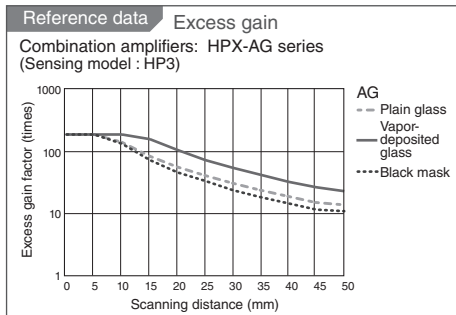
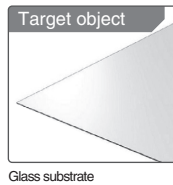
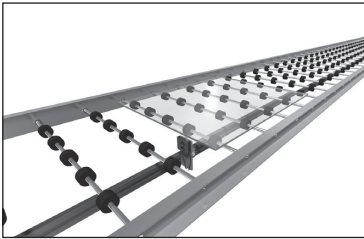

Selective reflection ▶ A-024

UNDERSTANDING THE GRAPHS

● Excess gain

The excess gain indicates the magnitude of output from the light-receiving element relative to the amount of light received by the fiber unit (which varies depending on the distance). The graph shows that at a distance of 1, the output from the light-receiving element is 10 times the level required for operation.

This surplus is available in case there is a decrease in the incoming light level due to misalignment of the optical axis, dirt on the light-receiving element, etc.

Note: On an excess gain graph, the minimum operating level of the amplifier is set at 1.

● Detection area

The detection area is a characteristic used for diffuse scans. The graph shows the operation points of the fiber switch when a standard target object (white paper) is moved perpendicular to the optical axis at the maximum sensitivity setting. This illustrates the extent of detectable light around the fiber unit.

Note: For the excess gain graph, the minimum operating level of amplifier unit is set as 1.

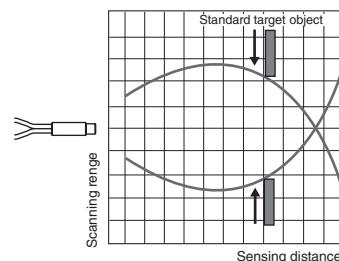
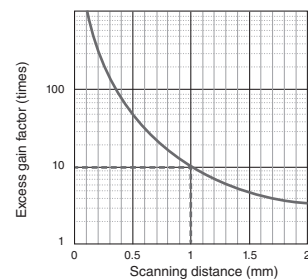

*Detection availability, measurement performance, and accuracy also depend on actual working conditions. Use the fiber unit after carrying out in advance an operation check and evaluation.

Screw Thru scan

Most generally used. Use by attaching to a bracket, etc.

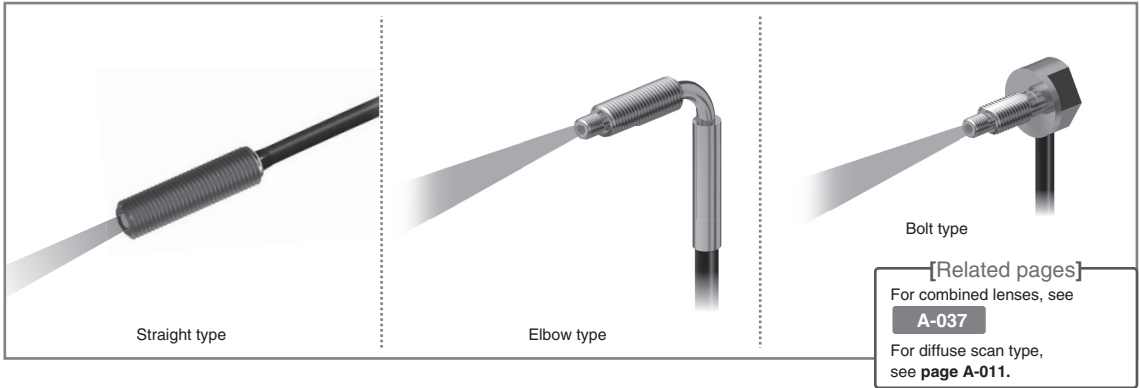

OUTER GUIDE

● Thru scan

Type	Size	Shape	Cable		Scanning distance (mm)			Core	Min. detectable size (mm)	Model No.
			Bend radius	Length	Amp	Mode	Distance			
Straight	M3	Shape A 	R1 Unbreakable	2 m Free cut	HPX-AG	HP FT = 140	φ0.5	φ0.005	HPF-T024	
					HPX-EG	nL FT = 50 FT = 29				
					HPX-H HPX-A	nL FT = 50 FT = 25				
		Shape B -30 to +70 °C	R4 Bend tolerant	2 m Free cut	HPX-AG	HP FT = 180	4×φ0.25	φ0.01	HPF-T008	
					HPX-EG	nL FT = 60 FT = 38				
					HPX-H HPX-A	nL FT = 100 FT = 40				
	M4	Shape B -30 to +70 °C	R20	2 m Free cut	HPX-AG	HP FT = 195 FT = 675	φ0.75	φ0.005	HPF-T044	
					HPX-EG	nL FT = 220 FT = 130				
					HPX-H HPX-A	nL FT = 220 FT = 110				
		Shape C Lens attachable -30 to +70 °C	R2	2 m Unbreakable	Free cut	HPX-AG	HP FT = 260 FT = 900	φ1.0	φ0.005	HPF-T025
						HPX-EG	nL FT = 310 FT = 180			
						HPX-H HPX-A	nL FT = 300 FT = 150			
Shape C -30 to +70 °C	R20	2 m Free cut	Free cut	HPX-AG	HP FT = 350 FT = 1,200	φ1.0	φ0.005	HPF-T003		
				HPX-EG	nL FT = 410 FT = 240					
				HPX-H HPX-A	nL FT = 400 FT = 200					
M4	Shape C -30 to +70 °C	R20	2 m Free cut	HPX-AG	HP FT = 630 FT = 2,175	φ1.4	φ0.01	HPF-T001		
				HPX-EG	nL FT = 770 FT = 450					
				HPX-H HPX-A	nL FT = 800 FT = 400					
	Shape D Lens attachable -30 to +70 °C	R4	2 m Bend tolerant	Free cut	HPX-AG	HP FT = 260 FT = 900	16×φ0.25	φ0.01	HPF-T033	
					HPX-EG	nL FT = 280 FT = 160				
					HPX-H HPX-A	nL FT = 265 FT = 130				
Bolt	M4	Shape E Lens attachable -30 to +70 °C	R2	2 m Unbreakable	Free cut	φ1.0	φ0.005	HPF-T025B		
									HPX-AG	HP FT = 260 FT = 900
									HPX-EG	nL FT = 310 FT = 180
									HPX-H HPX-A	nL FT = 300 FT = 150
Elbow	M4	Shape F Lens attachable -30 to +70 °C	R20	2 m Free cut	φ1.0	φ0.005	HPF-T010			
								HPX-AG	HP FT = 245 FT = 855	
								HPX-EG	nL FT = 300 FT = 170	
								HPX-H HPX-A	nL FT = 300 FT = 150	

*For scanning distances of the sensing modes, see the Technical Guide (page A-043).

*Response times for the sensing types: HP 5 ms, nL 1 ms, and FT 250 μs.

*The values shown in the Minimum detectable size column were obtained with optimal scanning distance and sensitivity settings (HPX-AG).

OUTER DIMENSIONS

(Unit:mm)

●Thru scan

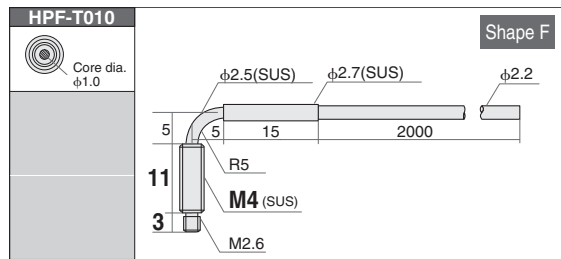
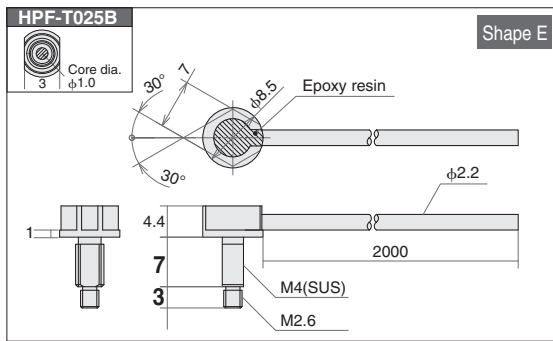
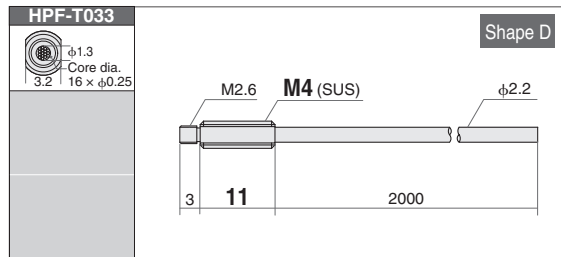
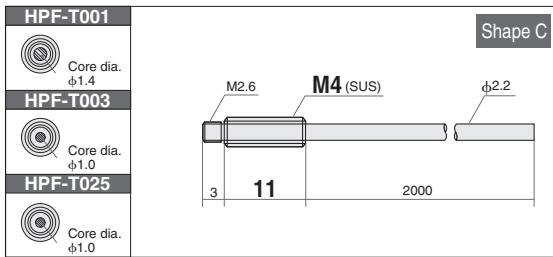
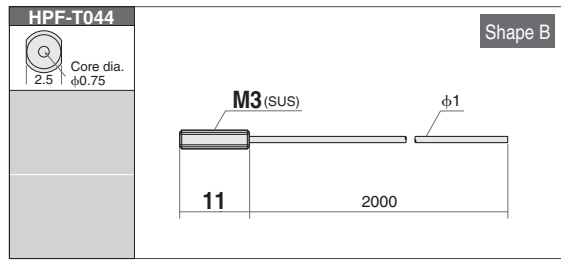
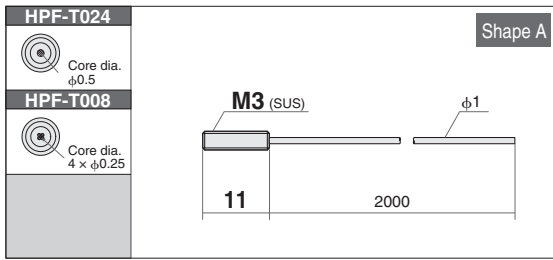

NOTEWORTHY

Products allowing either nut or setscrew installation are available for flexible operability, maintenance parts consolidation, and other factors.

HPF-T025B

Nut installation

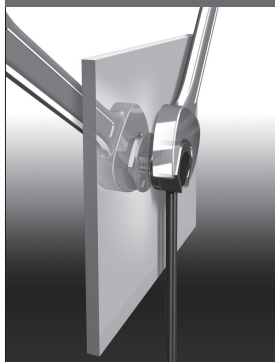

Setscrew installation

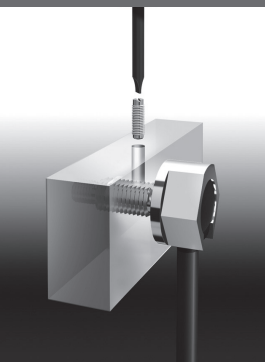

Attachment method selectable

◇Applicable model number

From	Type	Model no.
Thru scan	Straight	HPF-T033
Thru scan	Straight	HPF-T044
Thru scan	Bolt	HPF-T025B

D-Shape cutout





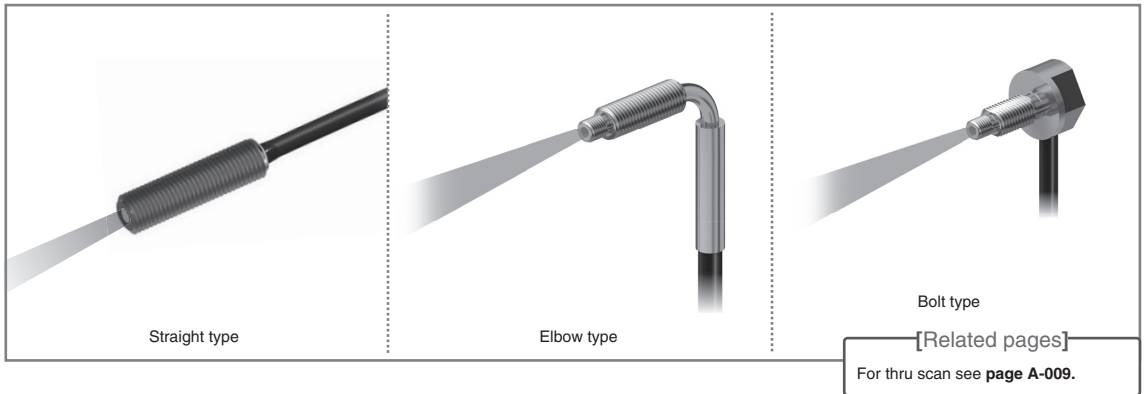

Screw Diffuse scan

Most generally used. Use by attaching to a bracket, etc.

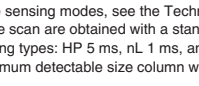

● OUDER GUIDE

● Diffuse scan

Type	Size	Shape	Cable		Scanning distance (mm)			Core	Min. detectable size (mm)	Model No.
			Bend radius	Length	Amp	Mode	Distance			
Straight	M3	Shape G 	R1	2 m Unbreakable Free cut	HPX-AG	HP FT 25 8	Receiver and emitter φ0.5	φ0.005	HPF-D029	
					HPX-EG	nL FT 10 5				
					HPX-H HPX-A	nL FT 10 5				
		Shape H 	R15	2 m Free cut	HPX-AG	HP FT 34 105	Receiver and emitter φ0.5	φ0.005	HPF-D004	
					HPX-EG	nL FT 43 25				
					HPX-H HPX-A	nL FT 40 20				
	M4	Shape I 	R4	2 m Bend tolerant Free cut	HPX-AG	HP FT 20 6	Receiver and emitter 2xφ0.25	φ0.005	HPF-D037	
					HPX-EG	nL FT 8 5				
					HPX-H HPX-A	nL FT 8 4				
		Shape J 	R15	2 m Free cut	HPX-AG	HP FT 65 200	Receiver and emitter φ0.75	φ0.005	HPF-D018	
					HPX-EG	nL FT 75 46				
					HPX-H HPX-A	nL FT 80 40				
M6	Shape J 	R2	2 m Unbreakable Free cut	HPX-AG	HP FT 69 210	Receiver and emitter φ1.0	φ0.005	HPF-D030		
				HPX-EG	nL FT 85 50					
				HPX-H HPX-A	nL FT 80 40					
	Shape J 	R4	2 m Bend tolerant Free cut	HPX-AG	HP FT 80 250	Receiver and emitter 16xφ0.25	φ0.005	HPF-D012		
				HPX-EG	nL FT 100 55					
				HPX-H HPX-A	nL FT 100 50					
Shape J 	R20	2 m Free cut	HPX-AG	HP FT 170 530	Receiver and emitter φ1.4	φ0.005	HPF-D001			
			HPX-EG	nL FT 210 120						
			HPX-H HPX-A	nL FT 230 120						
Shape J 	R20	2 m Free cut	HPX-AG	HP FT 130 400	Receiver and emitter φ1.0	φ0.005	HPF-D002			
			HPX-EG	nL FT 150 90						
			HPX-H HPX-A	nL FT 150 80						

*For scanning distances of the sensing modes, see the Technical Guide (page A-044).

*Scanning distances for diffuse scan are obtained with a standard target object (plain white paper).

*Response times for the sensing types: HP 5 ms, nL 1 ms, and FT 250 μs.

*The values shown in the Minimum detectable size column were obtained with optimal scanning distance and sensitivity settings (HPX-AG).

OUTER DIMENSIONS

(Unit:mm)

●Diffuse scan

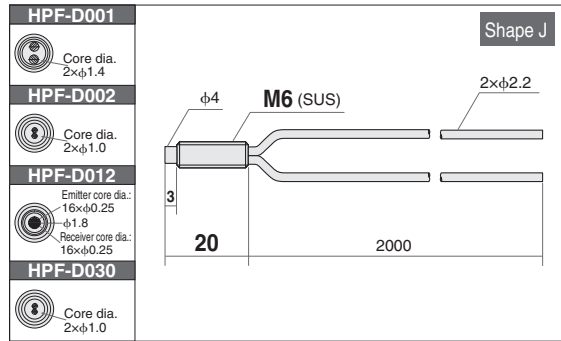
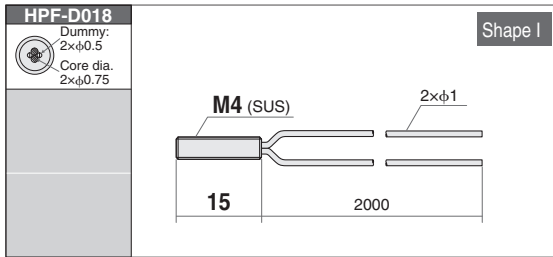
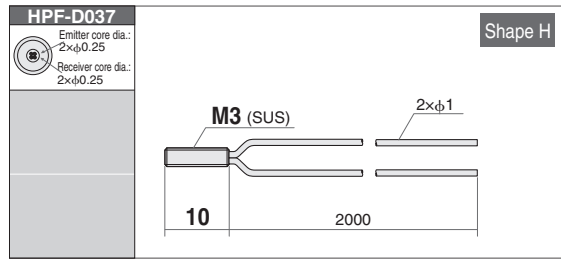
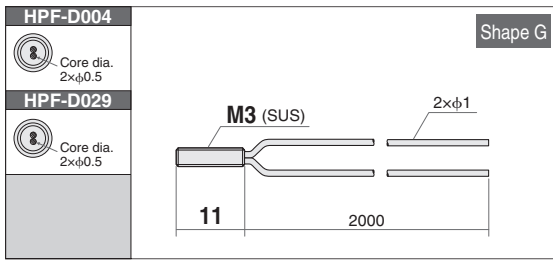

Cylindrical

Suitable for installation where space is limited. Use by attaching with the setscrew.

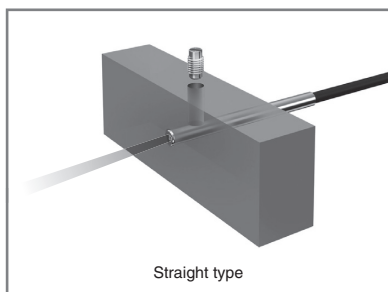

[Related pages]

Side-view switches **A-019**

Compatible lenses **A-037**

For head dia. of less than $\phi 1.0$ mm (thru scan) or $\phi 1.5$ mm (diffuse scan), select from sleeve-type switches.

A-017

ORDER GUIDE

● Thru scan

Type	Size	Shape	Cable		Scanning distance (mm)			Core	Min. detectable size (mm)	Model No.
			Bend radius	Length	Amp	Mode	Distance			
Straight	$\phi 1$	Shape A	R4	0.5 m	HPX-AG	HP FT	37 10	$\phi 0.25$	$\phi 0.005$	HPF-T038
		HPX-EG			nL FT	12 7				
					HPX-H HPX-A	12 6				
	Shape B	R4	2 m	Bend tolerant Free cut	HPX-AG	HP FT	180 52	4x $\phi 0.25$	$\phi 0.01$	HPF-T009
					HPX-EG	nL FT	60 38			
						HPX-H HPX-A	100 40			
	Shape C	R4	2 m	Bend tolerant Free cut	HPX-AG	HP FT	180 52	4x $\phi 0.25$	$\phi 0.01$	HPF-T046
					HPX-EG	nL FT	60 38			
						HPX-H HPX-A	100 40			
	Shape D	R4	0.5 m	Bend tolerant Free cut	HPX-AG	HP FT	18 5	$\phi 0.125$	$\phi 0.005$	HPF-T036
HPX-EG					nL FT	6 3				
					HPX-H HPX-A	6 3				
Shape E	R15	2 m	Free cut	HPX-AG	HP FT	85 300	$\phi 0.5$	$\phi 0.005$	HPF-T043	
				HPX-EG	nL FT	100 55				
					HPX-H HPX-A	100 50				
Shape F	R2	2 m	Unbreakable Free cut	HPX-AG	HP FT	900 260	$\phi 1.0$	$\phi 0.005$	HPF-T031	
				HPX-EG	nL FT	310 180				
					HPX-H HPX-A	300 150				
Shape G	R20	2 m	Free cut	HPX-AG	HP FT	350 1,200	$\phi 1.0$	$\phi 0.005$	HPF-T004	
				HPX-EG	nL FT	410 240				
					HPX-H HPX-A	400 200				
Shape G	R20	2 m	Free cut	HPX-AG	HP FT	630 2,175	$\phi 1.4$	$\phi 0.01$	HPF-T002	
				HPX-EG	nL FT	770 450				
					HPX-H HPX-A	800 400				

● Diffuse scan

Type	Size	Shape	Cable		Scanning distance (mm)			Core	Min. detectable size (mm)	Model No.
			Bend radius	Length	Amp	Mode	Distance			
Straight	$\phi 1.5$	Shape H	R4	1 m	HPX-AG	HP FT	20 6	Receiver and emitter 2x $\phi 0.25$	$\phi 0.005$	HPF-D036
		HPX-EG			nL FT	8 5				
Shape I	R15		2 m	Free cut	HPX-AG	HP FT	105 34	Receiver and emitter $\phi 0.5$	$\phi 0.005$	HPF-D005
		HPX-EG			nL FT	43 25				
Shape I	R15		2 m	Free cut	HPX-H HPX-A	40 20				

*For scanning distances of the sensing modes, see the Technical Guide (page A-043).

*Scanning distances for diffuse scan are obtained with a standard target object (plain white paper).

*Response times for the sensing types: HP 5 ms, nL 1 ms, and FT 250 μ s.

*The values shown in the Minimum detectable size column were obtained with optimal scanning distance and sensitivity settings (HPX-AG).

OUTER DIMENSIONS

(Unit:mm)

●Thru scan

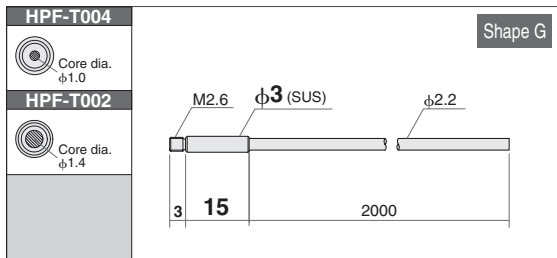
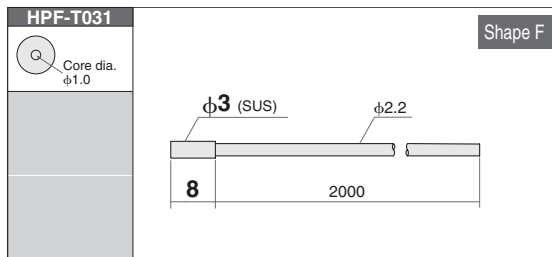
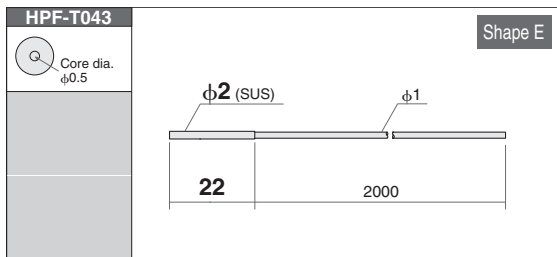
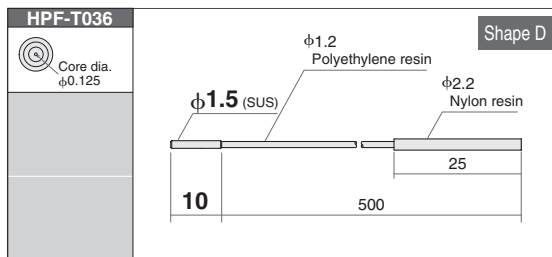
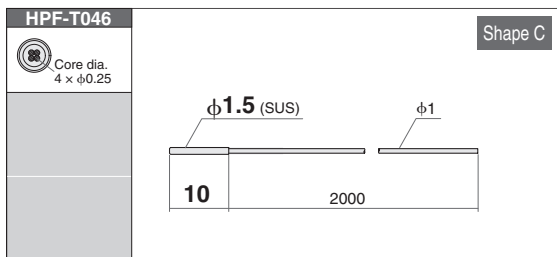
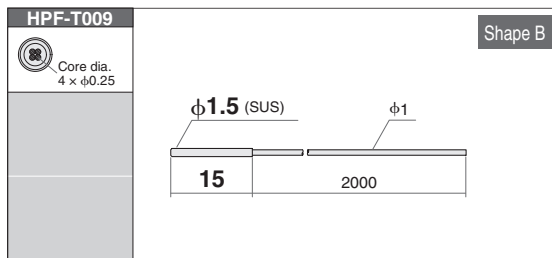
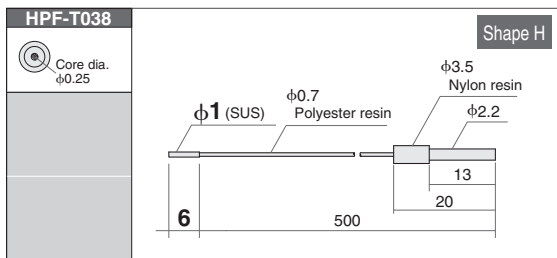

●Diffuse scan

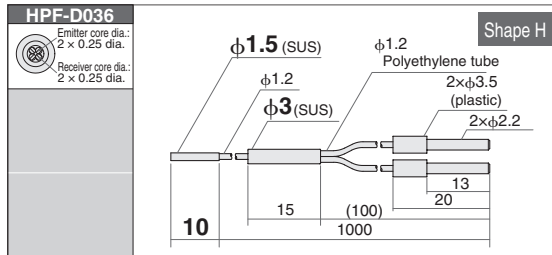
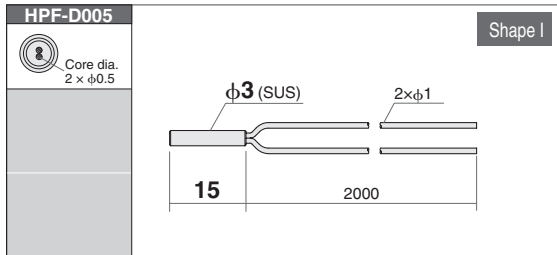

NOTEWORTHY

Smallest fiber unit head dia. (1.0 mm) in the industry

HPF-T038

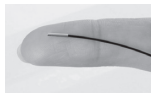

Compatible lens units are available for cylindrical types



FE-PA-L1(For long distance and narrow beam types)



FE-PA-S1(For side view types)

HPF-T004

Coaxial

Used for target object positioning or in combination with spot lenses.

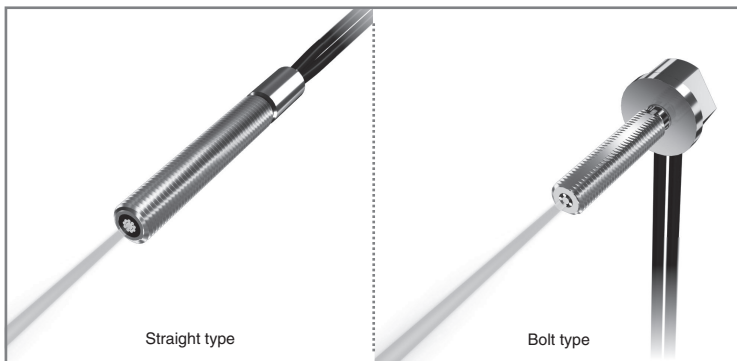

[Related pages]
For compatible micro-spot lenses
A-035

● OUDER GUIDE

● Diffuse scan

Type	Size	Shape	Cable		Scanning distance (mm)				Core	Min. detectable size (mm)	Model No.
			Bend radius	Length	Amp	Mode	Distance				
Straight	M3	Shape A Lens attachable -30 to +70°C	R4 Bend tolerant	0.5 m	HPX-AG HPX-EG HPX-H HPX-A	HP FT nL FT	60 19 25 15 25 13	Emitter : φ0.25 Receive : 6×φ0.25	φ0.005	HPF-D034	
		Shape B Lens attachable	Emitter: R1 Receiver: R4 Unbreakable	2 m Free cut	HPX-AG HPX-EG HPX-H HPX-A	HP FT nL FT	46 15 18 10 18 10	Emitter : φ0.5 Receive : 4×φ0.25			
		Shape C Lens attachable -30 to +70°C	R15 Free cut	2 m Free cut	HPX-AG HPX-EG HPX-H HPX-A	HP FT nL FT	86 28 35 21 40 20	Emitter : φ0.5 Receive : 4×φ0.25			
		Shape D Lens attachable -30 to +70°C	R4 Free cut	1 m Free cut	HPX-AG HPX-EG HPX-H HPX-A	HP FT nL FT	160 55 60 38 60 34	Emitter : φ0.5 Receive : 9×φ0.25			
		Shape E Lens attachable -30 to +70°C	Emitter:R1 Receiver:R4 Unbreakable	1 m Free cut	HPX-AG HPX-EG HPX-H HPX-A	HP FT nL FT	46 15 18 10 18 10	Emitter : φ0.5 Receive : 4×φ0.25			
Straight	M4	Shape F Lens attachable -30 to +70°C	R15 Free cut	2 m Free cut	HPX-AG HPX-EG HPX-H HPX-A	HP FT nL FT	95 43 50 29 50 25	Emitter : φ0.5 Receive : 9×φ0.25	φ0.005	HPF-D038	
		Shape G Lens attachable -30 to +70°C	R20 Free cut	2 m Free cut	HPX-AG HPX-EG HPX-H HPX-A	HP FT nL FT	400 130 150 90 150 80	Emitter : φ1.0 Receive : 16×φ0.25			
	φ2	Shape H Lens attachable -30 to +70°C	R15 Free cut	2 m Free cut	HPX-AG HPX-EG HPX-H HPX-A	HP FT nL FT	86 28 35 21 40 20	Emitter : φ0.5 Receive : 4×φ0.25	φ0.005	HPF-D042	
		Shape I Lens attachable -30 to +70°C	R15 Free cut	2 m Free cut	HPX-AG HPX-EG HPX-H HPX-A	HP FT nL FT	95 43 50 29 50 25	Emitter : φ0.5 Receive : 9×φ0.25			

*For scanning distances of the sensing modes, see the Technical Guide (page A-044).

*Scanning distances for diffuse scan are obtained with a standard target object (plain white paper).

*Response times for the sensing types: HP 5 ms, nL 1 ms, and FT 250 μs.

*The values shown in the Minimum detectable size column were obtained with optimal scanning distance and sensitivity settings (HPX-AG).

OUTER DIMENSIONS

(Unit: mm)

●Diffuse scan

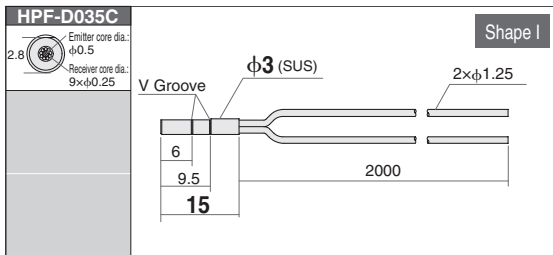
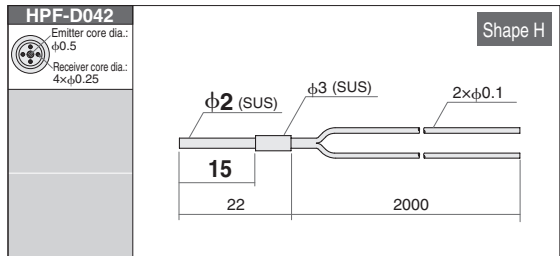
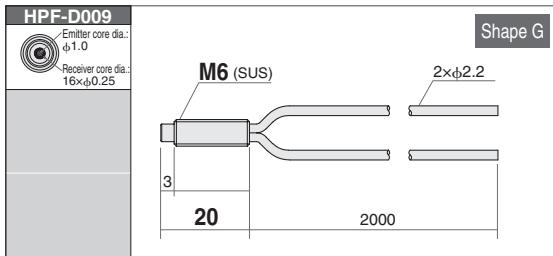
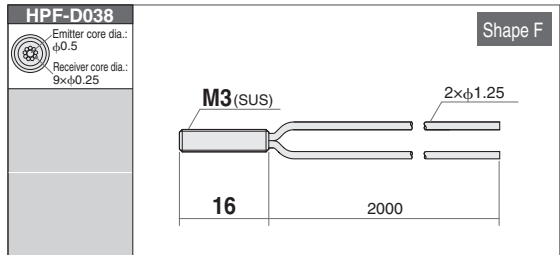
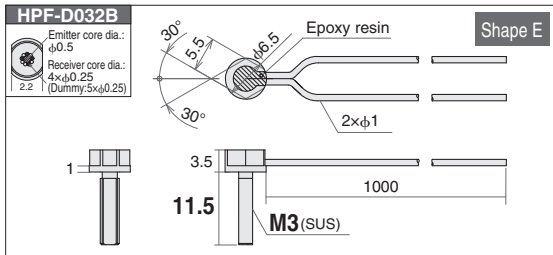
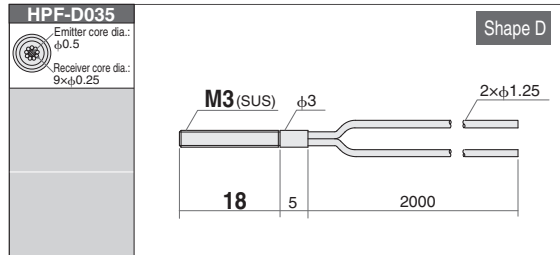
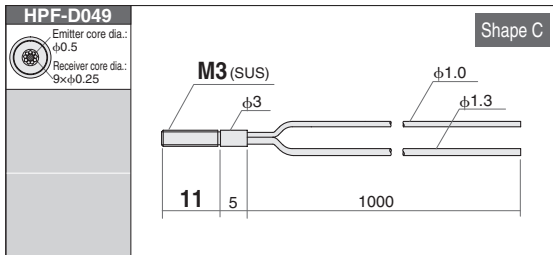
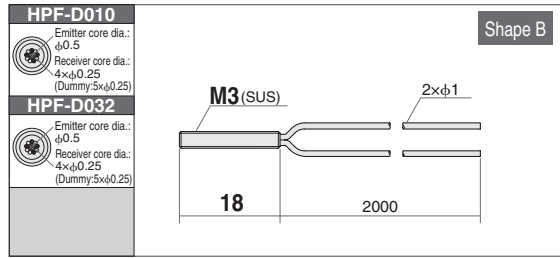
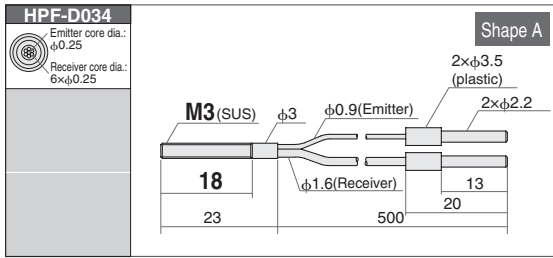

NOTEWORTHY

Coaxial fiber is recommended for use with micro-spot lenses and applications requiring highly precise positioning.

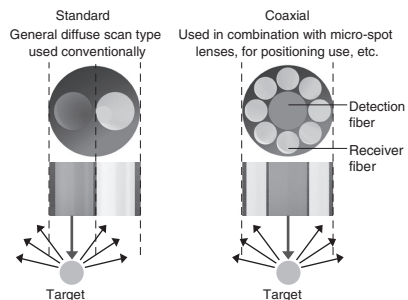

Sleeve

Use to maintain a small distance between target object and switch in a limited space.

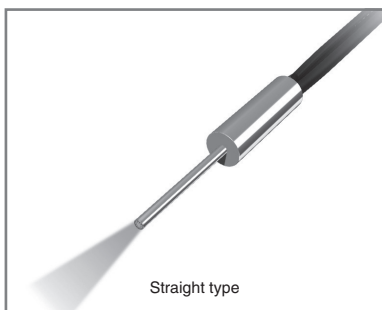

[Related pages]

Sleeve-length customization

A-008

Side-view sensing

A-019

ORDER GUIDE

● Thru scan

Front end dia.	Shape	Cable		Scanning distance (mm)			Core	Min. detectable size (mm)	Model No.
		Bend radius	Length	Amp	Mode	Distance			
φ0.4	Shape A -30 to +70°C	R4	0.5 m	HPX-AG	HP	18	φ0.125	φ0.005	HPF-T039
					FT	5			
				HPX-EG	nL	5			
φ0.5	Shape B -30 to +70°C	R15	2 m Free cut	HPX-AG	HP	37	φ0.25	φ0.005	HPF-T015
					FT	10			
				HPX-EG	nL	12			
φ1.2 Extendable Bendable (10-mm radius)	Shape C -30 to +70°C	R20	2 m Free cut	HPX-AG	HP	350	φ1.0	φ0.005	HPF-T005
					FT	1,200			
				HPX-EG	nL	410			
φ1.2 Bendable (10-mm radius)	Shape D -30 to +70°C	R20	2 m Free cut	HPX-AG	HP	400	φ1.0	φ0.005	HPF-T006
					FT	200			
				HPX-EG	nL	350			

● Diffuse scan

Front end dia.	Shape	Cable		Scanning distance (mm)			Core	Min. detectable size (mm)	Model No.
		Bend radius	Length	Amp	Mode	Distance			
φ0.82	Shape E -30 to +70°C	R4	0.5 m Bend tolerant Free cut	HPX-AG	HP	20	Receiver and emitter φ0.25	φ0.005	HPF-D039
					FT	6			
				HPX-EG	nL	4			
φ0.82	Shape F -30 to +70°C	R15	0.5 m Free cut	HPX-AG	HP	20	Receiver and emitter φ0.25	φ0.005	HPF-D019
					FT	6			
				HPX-EG	nL	4			
φ1.2 Extendable Bendable (10-mm radius)	Shape G -30 to +70°C	R15	2 m Free cut	HPX-AG	HP	105	Receiver and emitter φ0.5	φ0.005	HPF-D006
					FT	34			
				HPX-EG	nL	43			
φ1.5	Shape H -30 to +70°C	R15	2 m Free cut	HPX-AG	HP	86	Receiver and emitter φ0.5	φ0.005	HPF-D021
					FT	28			
				HPX-EG	nL	35			
φ2.5 Extendable Bendable (10-mm radius)	Shape I -30 to +70°C	R20	2 m Free cut	HPX-AG	HP	400	Receiver and emitter φ1.0	φ0.005	HPF-D003
					FT	130			
				HPX-EG	nL	150			

*For scanning distances of the sensing modes, see the Technical Guide (page A-043).

*Scanning distances for diffuse scan are obtained with a standard target object (plain white paper).

*Response times for the sensing types: HP 5 ms, nL 1 ms, and FT 250 μs.

*The values shown in the Minimum detectable size column were obtained with optimal scanning distance and sensitivity settings (HPX-AG).

OUTER DIMENSIONS

(Unit: mm)

●Thru scan

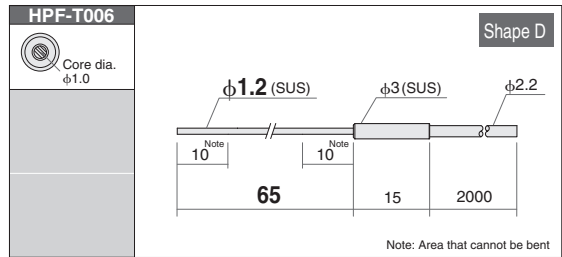
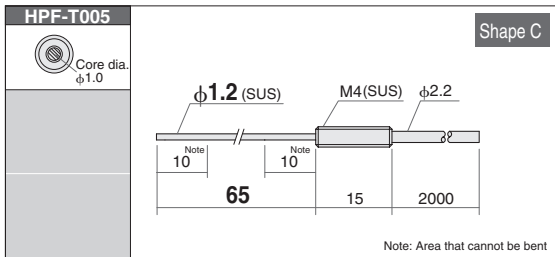
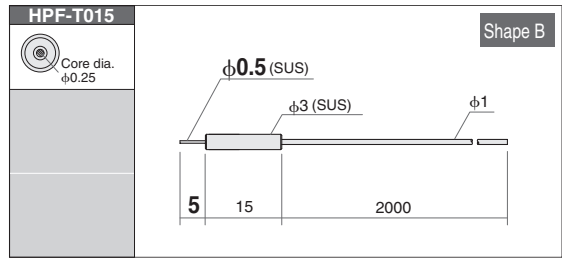
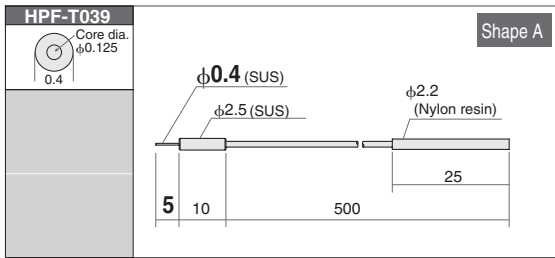

●Diffuse scan

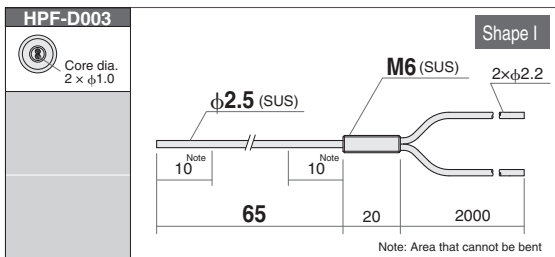
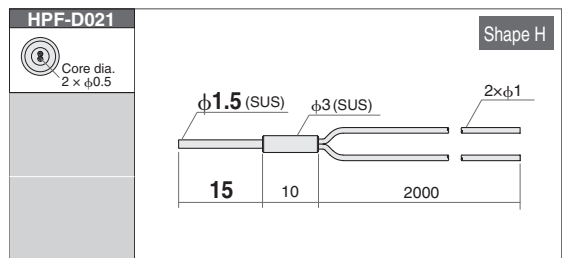
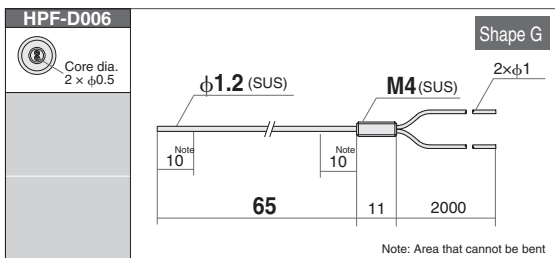
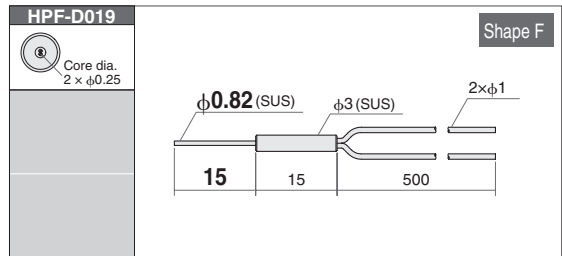
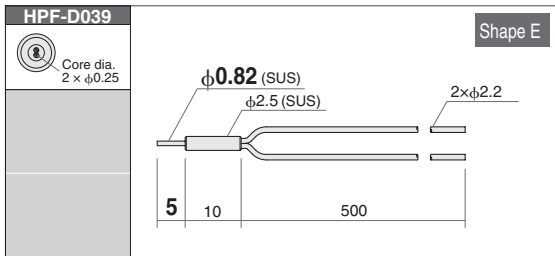

Side view

Light emitted to the side.

Use to maintain a small distance between target object and switch in a limited space.

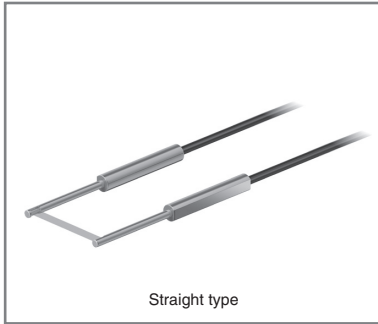

[Related pages]

Narrow view sensing

A-021

Sleeve-length customization

A-008

ORDER GUIDE

●Thru scan

Front end dia.	Center of optical axis (From front end)	Shape	Cable		Scanning distance (mm)			Core	Min. detectable size (mm)	Model No.
			Bend radius	Length	Amp	Mode	Distance			
Extendable φ0.88	0.6	Shape A -30 to +70°C	R5	1 m Free cut	HPX-AG	HP FT = 15	52	φ0.5	φ0.005	HPF-T037
					HPX-EG	nL FT = 11	20			
					HPX-H	20				
					HPX-A	10				
φ1	1.5	Shape B -30 to +70°C	R1	2 m Unbreakable Free cut	HPX-AG	HP FT = 15	52	φ0.5	φ0.005	HPF-T026
					HPX-EG	nL FT = 11	20			
					HPX-H	20				
					HPX-A	10				
φ1	1.5	Shape C -30 to +70°C	R15	2 m Free cut	HPX-AG	HP FT = 48	165	φ0.5	φ0.005	HPF-T007
					HPX-EG	nL FT = 33	55			
					HPX-H	60				
					HPX-A	30				
φ3	1.5	Shape D -30 to +70°C	R5	2 m Free cut	HPX-AG	HP FT = 15	190	φ0.5	φ0.005	HPF-T042
					HPX-EG	nL FT = 11	220			
					HPX-H	240				
					HPX-A	120				

●Diffuse scan

Front end dia.	Center of optical axis (From front end)	Shape	Cable		Scanning distance (mm)			Core	Min. detectable size (mm)	Model No.
			Bend radius	Length	Amp	Mode	Distance			
Extendable φ2	1.5	Shape E -30 to +70°C	R15	2 m Free cut	HPX-AG	HP FT = 13	40	Receiver and emitter φ0.5	φ0.005	HPF-D011
					HPX-EG	nL FT = 10	17			
					HPX-H	15				
					HPX-A	8				
φ2	1.5	Shape F -30 to +70°C	R15	2 m Free cut	HPX-AG	HP FT = 13	40	Receiver and emitter φ0.5	φ0.005	HPF-D041
					HPX-EG	nL FT = 10	17			
					HPX-H	15				
					HPX-A	8				
φ6	1.5	Shape G -30 to +70°C	R20	2 m Free cut	HPX-AG	HP FT = 52	160	Receiver and emitter φ1.0	φ0.005	HPF-D043
					HPX-EG	nL FT = 40	65			
					HPX-H	50				
					HPX-A	32				

*For scanning distances of the sensing modes, see the Technical Guide (page A-043).

*Scanning distances for diffuse scan are obtained with a standard target object (plain white paper).

*Response times for the sensing types: HP 5 ms, nL 1 ms, and FT 250 μs.

*The values shown in the Minimum detectable size column were obtained with optimal scanning distance and sensitivity settings (HPX-AG).

OUTER DIMENSIONS

(Unit: mm)

●Thru scan

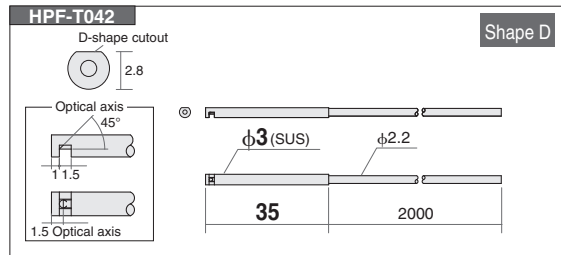
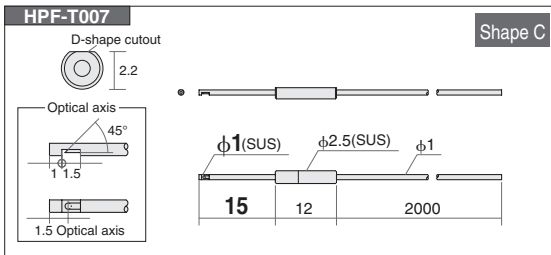
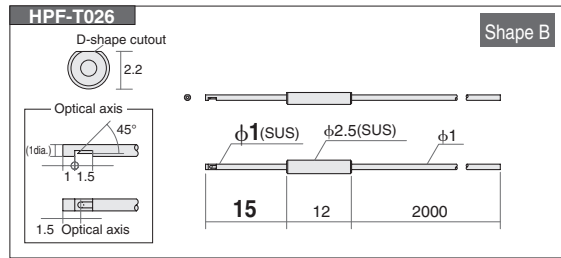
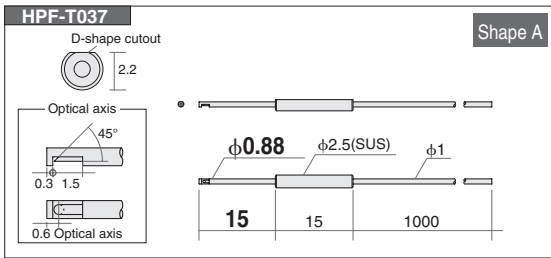

●Diffuse scan

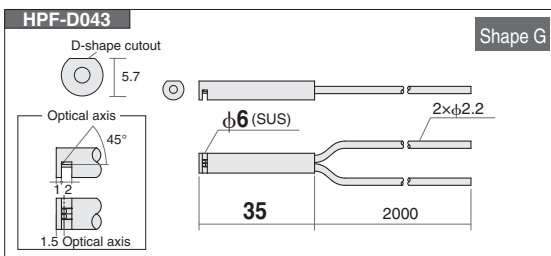
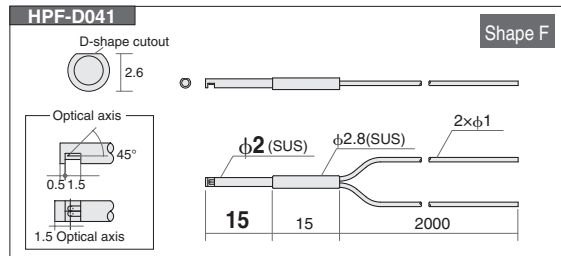
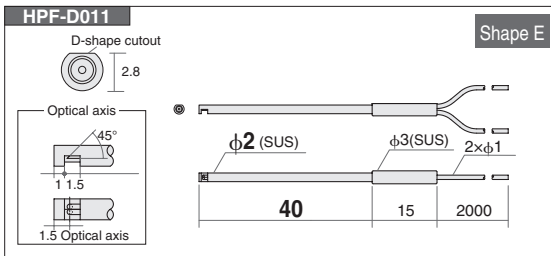

NOTEWORTHY

Unique feature

All side view types have D-shape cutout on the fiber unit head. This can greatly reduce adjustment man-hours during installation.

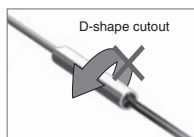
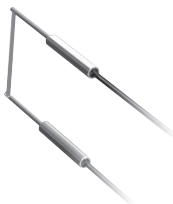

The D-shape cutout perpendicular to the optical axis facilitates alignment.

Selection point

The distance from the front end to the center of the optical axis depends on the product structure. Select the model that is suitable for your application.

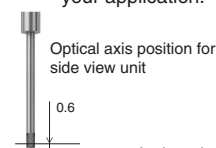

(Example)



In detection of small component dislocation, the distance from the front end to the center of the optical axis is important.

Narrow view

Light spread minimized. Use in a place where light intrusion is undesirable.

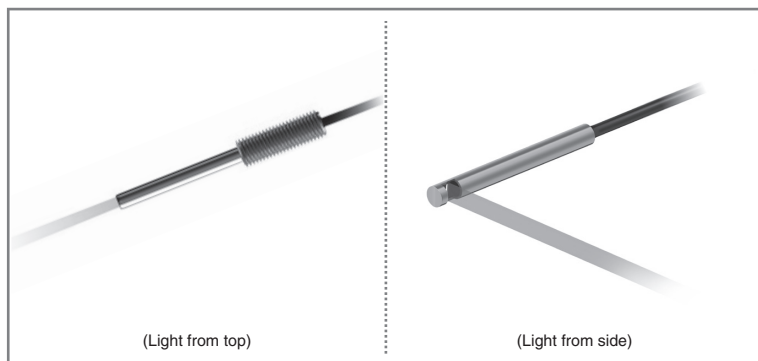

[Related pages]

If a narrow beam is not required:

Sleeve-type units : **A-017**

Side-view units : **A-019**

OUTER GUIDE

● Thru scan

Light emitter	Directional angle (half angle)	Shape	Cable		Scanning distance (mm)			Effective lens diameter	Min. detectable size (mm)	Model No.
			Bend radius	Length	Amp	Mode	Distance			
Side	1.5°	Shape A 	R5	2 m Free cut	HPX-AG	HP	500	φ1.5	φ0.005	HPF-T030
						FT	305			
					HPX-EG	nL	310			
						FT	180			
		HPX-H		350						
		HPX-A		175						
Top	1.5°	Shape B 	R15	2 m Free cut	HPX-AG	HP	3,600	φ1.7	φ0.1	HPF-T023
						FT	1,350			
					HPX-EG	nL	1,200			
						FT	730			
		HPX-H		1,200						
		HPX-A		600						
Top	2.5°	Shape C 	R20	2 m Free cut	HPX-AG	HP	4,100	φ2.1	φ0.1	HPF-T019
						FT	1,200			
					HPX-EG	nL	1,400			
						FT	840			
		HPX-H		1,500						
		HPX-A		750						
Side	3°	Shape D 	R20	2 m Free cut	HPX-AG	HP	4,500	φ2.6	φ0.1	HPF-T020
						FT	1,310			
					HPX-EG	nL	1,500			
						FT	920			
		HPX-H		1,600						
		HPX-A		800						

● Diffuse scan

Light emitter	Directional angle (half angle)	Shape	Cable		Scanning distance (mm)			Effective lens diameter	Min. detectable size (mm)	Model No.
			Bend radius	Length	Amp	Mode	Distance			
Top	—	Shape E 	R15	2 m Free cut	HPX-AG	HP	20	—	φ0.005	HPF-D025
						FT	20			
					HPX-EG	nL	20			
						FT	16			
		HPX-H		20						
		HPX-A		20						

*For scanning distances of the sensing modes, see the Technical Guide (page A-043).

*Scanning distances for diffuse scan are obtained with a standard target object (plain white paper).

*Response times for the sensing types: HP 5 ms, nL 1 ms, and FT 250 μs.

*The values shown in the Minimum detectable size column were obtained with optimal scanning distance and sensitivity settings (HPX-AG).

OUTER DIMENSIONS

(Unit: mm)

●Thru scan

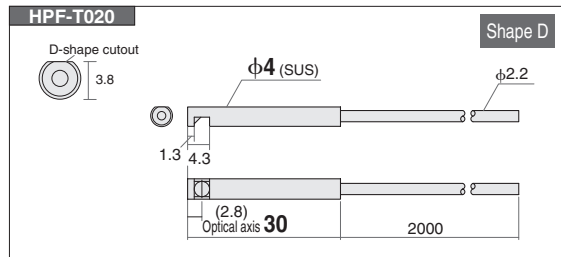
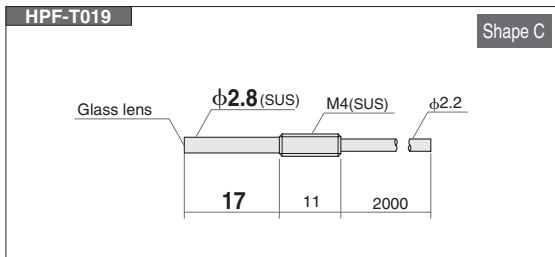
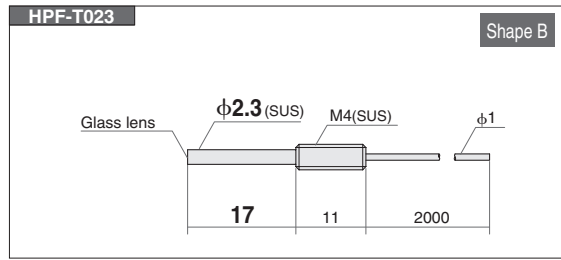
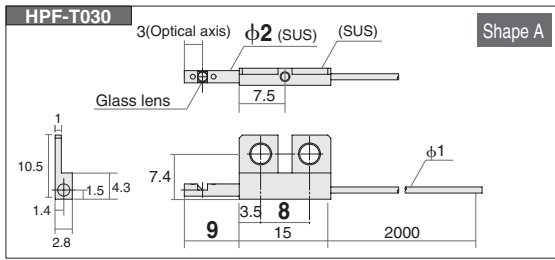

●Diffuse scan

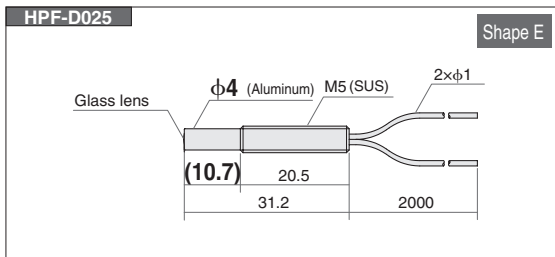

NOTEWORTHY

Narrow view types are available also by combination with long-distance lenses and side-view lenses.

(Typical examples)

Optical configuration	Lens unit	Fiber unit	Directional angle (half angle)
Top	FE-PA-L1	HPF-T003	Approx. 3°
Top	HPF-VL06	HPF-T003	Approx. 3°
Side	FE-PA-S1	HPF-T003	Approx. 10°
Side	HPF-VL05	HPF-T003	Approx. 8°

*For lens units, see page A-037.

Flat/Vane

Suitable for installation where space is limited. Attach directly to casing.

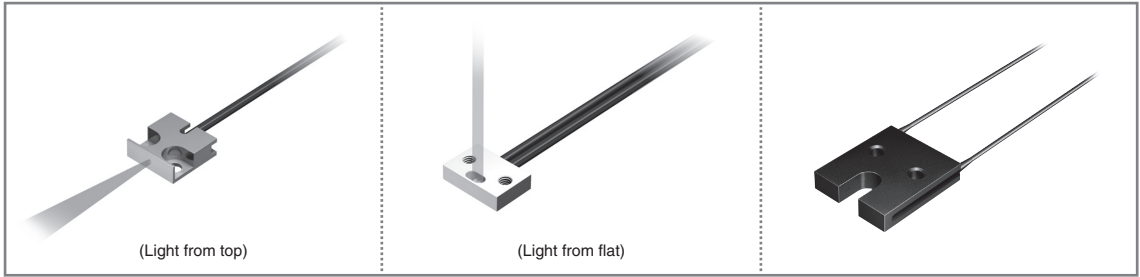

● OUTER GUIDE

● Thru scan

Type	Light emitter	Shape	Cable		Scanning distance (mm)			Core	Min. detectable size (mm)	Model No.
			Bend radius	Length	Amp	Mode	Distance			
Flat	Top	Shape A	R1	2 m	HPX-AG	HP FT	140	φ0.5	φ0.005	HPF-T028
					HPX-EG	nL FT	50			
					HPX-H	FT	29			
	Flat	Shape B	R5	2 m	HPX-AG	HP FT	210			
					HPX-EG	nL FT	80			
					HPX-H	FT	47			
Vane type	-	Shape C	R15	5 m	HPX-AG	HP FT	6	φ0.5	φ0.005	HPF-T054-L05
					HPX-EG	nL FT	6			
					HPX-H	FT	6			
					HPX-A	HP FT	6			
					HPX-A	nL FT	6			
					HPX-A	FT	6			

● Diffuse scan

Type	Light emitter	Shape	Cable		Scanning distance (mm)			Core	Min. detectable size (mm)	Model No.
			Bend radius	Length	Amp	Mode	Distance			
Flat	Flat	Shape D	R2	2 m	HPX-AG	HP FT	93	Receiver and emitter φ1.0	-	HPF-D045LF
					HPX-EG	nL FT	37			
					HPX-H	FT	21			
					HPX-A	HP FT	35			
					HPX-A	nL FT	17			
					HPX-A	FT	17			

*For scanning distances of the sensing modes, see the Technical Guide (page A-043).

*Scanning distances for diffuse scan are obtained with a standard target object (plain white paper).

*Response times for the sensing types: HP 5 ms, nL 1 ms, and FT 250 μs.

*The values shown in the Minimum detectable size column were obtained with optimal scanning distance and sensitivity settings (HPX-AG).

● OUTER DIMENSIONS

(Unit: mm)

● Thru scan

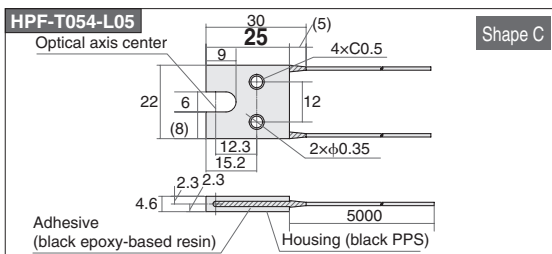
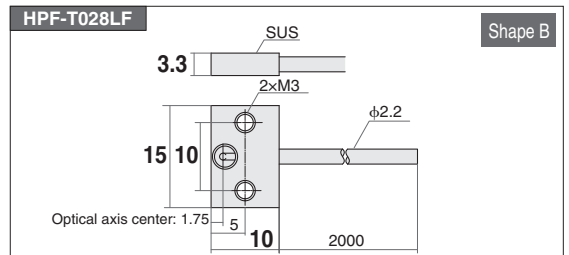
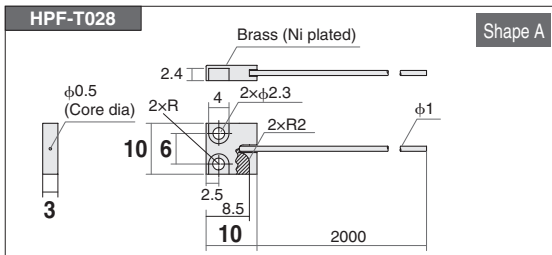

● Diffuse scan

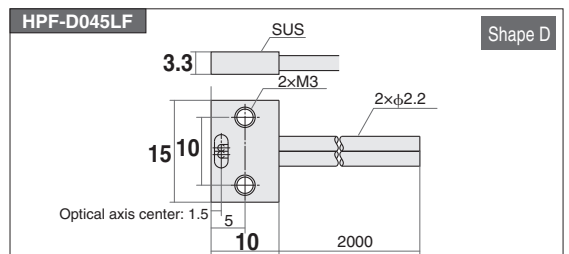

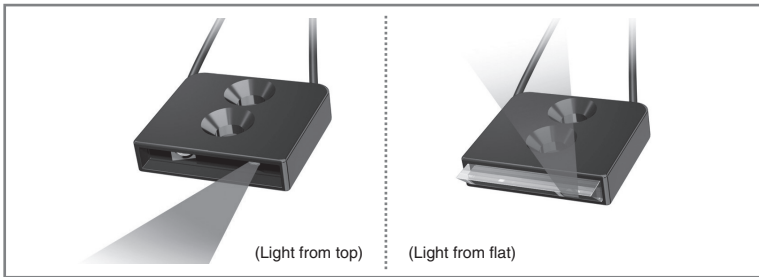

Selective reflection

Resistant to ambient influences. Use for target object detection in a limited area.

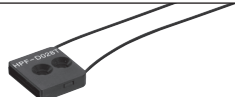

ORDER GUIDE

● Diffuse scan

Light emitter	Shape	Cable		Scanning distance (mm)			Min. detectable size (mm)	Model No.
		Bend radius	Length	Amp	Mode	Distance		
Top	Shape A 	R15	2 m Free cut	HPX-AG	HP	2.5±0.5	φ0.005	HPF-D028
	nL				2.5±0.5			
	Shape B 	R15	2 m Free cut	HPX-AG	HP	7.4±1.6	φ0.005	HPF-D028T
	nL				7.4±1.6			
	Shape C 	R15	2 m Free cut	HPX-AG	SF	2.5±0.5	φ0.005	HPF-D028F
					FT	2.5±0.5		
Flat	Shape C 	R15	2 m Free cut	HPX-EG	nL	7.4±1.2	φ0.005	HPF-D028F
					HP	5.2±1.6		
					nL	5.2±1.6		
					SF	5.2±1.6		
					FT	5.2±1.6		
				HPX-EG	nL	5.2±1.0		

*For scanning distances of the sensing modes, see the Technical Guide (page A-044).

*Scanning distances for diffuse scan are obtained with a standard target object (plain white paper).

*Response times for the sensing types: HP 5 ms, nL 1 ms, and FT 250 μs.

*The values shown in the Minimum detectable size column were obtained with optimal scanning distance and sensitivity settings (HPX-AG).

OUTER DIMENSIONS

(Unit: mm)

● Diffuse scan

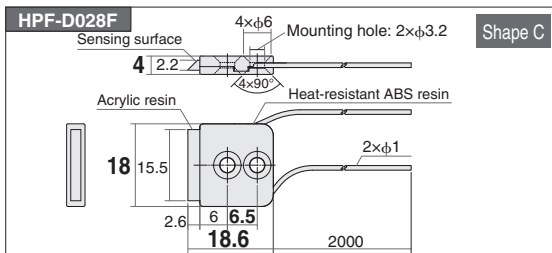
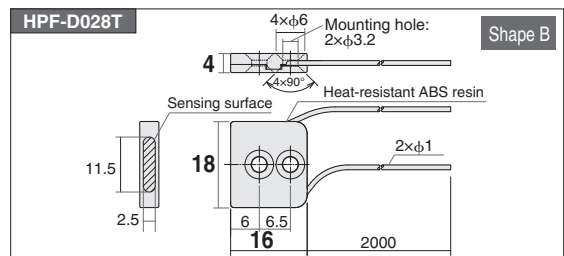
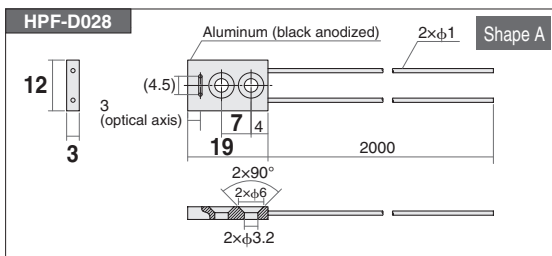

Area

Wide light beam.

Use for target object with varying detection positions, detection of meandering, etc.

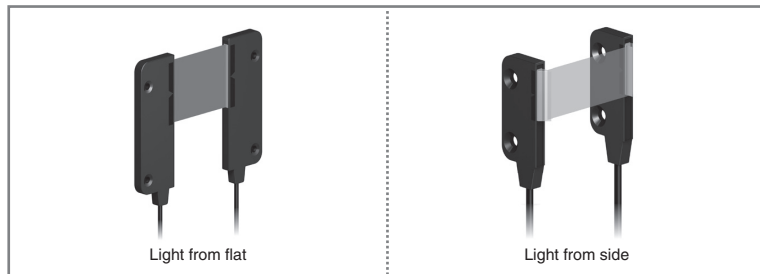

[Related pages]

Small part passage sensing

A-033

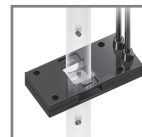

OUTER GUIDE

● Thru scan

Type	Optical configuration	Area width (mm)	Shape	Cable		Scanning distance (mm)			Min. detectable size (mm)	Model No.	
				Bend radius	Length	Amp	Mode	Distance			
Array	Flat	5.25	Shape A 	R4 Bend tolerant	2 m Free cut	HPX-AG	HP	225	780	φ0.2	HPF-T021
						HPX-EG	nL	270			
							FT	180			
						HPX-H		250			
						HPX-A		125			
Screen	Flat	15	Shape B 	R15	2 m Free cut	HPX-AG	HP	3,600		φ0.2	HPF-T021T
							FT	1,050			
						HPX-EG	nL	270	1,200		
							FT	180	710		
	Flat	30	Shape D 	R15	2 m Free cut	HPX-AG	HP	3,600		φ0.4	HPF-T021WT
							FT	1,750			
						HPX-EG	nL	2,000	1,100		
							FT	1,100			
	Side	15	Shape C 	R15	2 m Free cut	HPX-AG	HP	3,450		φ0.2	HPF-T021S
							FT	1,000			
						HPX-EG	nL	670	1,100		
							FT	550	1,100		

● Diffuse scan

Type	Optical configuration	Area width (mm)	Shape	Cable		Scanning distance (mm)			Min. detectable size (mm)	Model No.
				Bend radius	Length	Amp	Mode	Distance		
Array	Flat	10.85	Shape E 	R4	2 m	HPX-AG	HP	265	φ0.005	HPF-D026
							FT	85		
						HPX-EG	nL	100		
							FT	60		
						HPX-H		100		

*For scanning distances of the sensing modes, see the Technical Guide (page A-043).

*Scanning distances for diffuse scan are obtained with a standard target object (plain white paper).

*Response times for the sensing types: HP 5 ms, nL 1 ms, and FT 250 μs.

*The values shown in the Minimum detectable size column were obtained with optimal scanning distance and sensitivity settings (HPX-AG).

NOTEWORTHY

Type

Features

Array type



Small diameter fibers are aligned in a row. Smaller and slimmer switch heads are also available.

Screen type



Light is collimated using the lens. This increases the scanning range and makes the light uniform.

OUTER DIMENSIONS

(Unit: mm)

●Thru scan

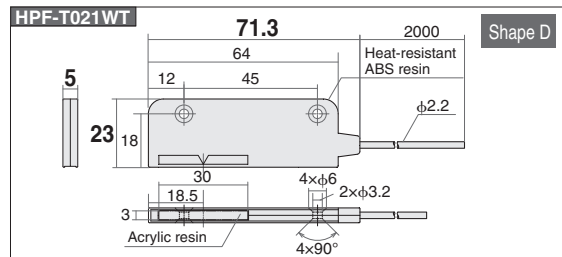
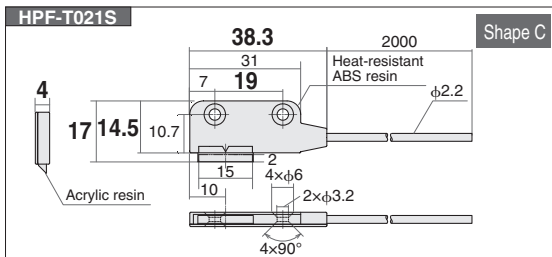
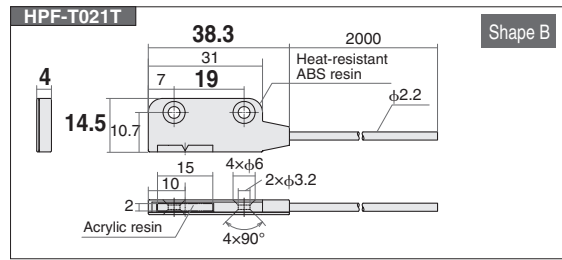
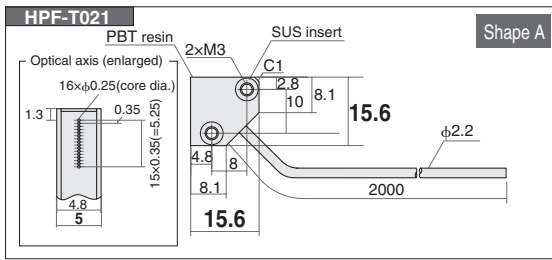

●Diffuse scan

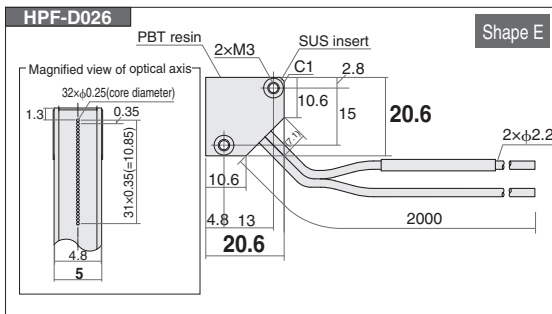

●Accessory

HPX-T021T

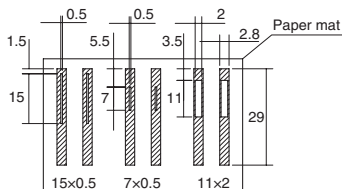

Note

Material: Transparent polyester film (black print on back)

HPF-T021T comes with slits.

Use the appropriate slit with the unit to achieve the desired scanning distance and resolution.

The slits can be bought as parts.

Model No : **HPX - PA07**

HPX-T021WT

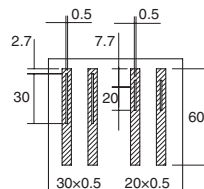

Note

Material: Transparent polyester film (black print on back)

HPF-T021WT comes with slits.

Use the appropriate slit with the unit to achieve the desired scanning distance and resolution.

Heatproof

Resistant to high temperatures. Use in environments up to 350°C.

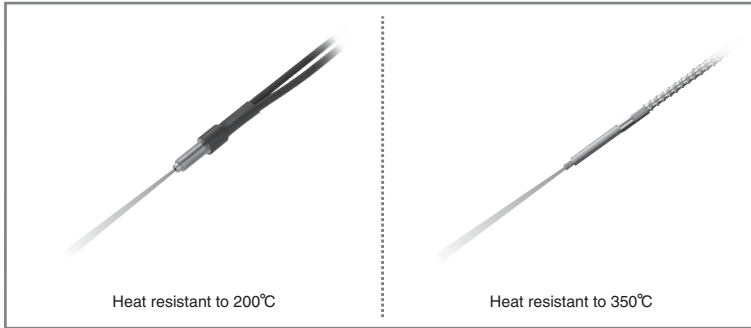

[Related pages]

Compatible lenses

A-037

OUDER GUIDE

● Thru scan

Heatproof	Size	Shape	Cable		Scanning distance (mm)			Element	Min. detectable size (mm)	Model No.	
			Bend radius	Length	Amp	Mode	Distance				
105°C	Straight	Shape A Lens attachable -30 to +105°C	R25	2 m Free cut	HPX-AG	HP	200	690	φ1.0	φ0.005	HPF-T012 ^{*1}
						FT	240	140			
						nL	250				
						FT	120				
150°C	Straight	Shape B -60 to +150°C	R35	2 m Free cut	HPX-AG	HP	350	1,200	φ1.5	φ0.01	HPF-T017 ^{*1}
						FT	410	240			
						nL	400				
						FT	200				
200°C	Straight	Shape C Lens attachable -30 to +200°C	R15	1 m	HPX-AG	HP	175	615	φ1.0	φ0.005	HPF-T018
						FT	140	80			
						nL	200				
						FT	100				
350°C	Straight	Shape D Lens attachable -30 to +350°C	R15	2 m	HPX-AG	HP	190	660	φ1.0	φ0.005	HPF-T014
						FT	220	130			
						nL	250				
						FT	120				

● Diffuse scan

Heatproof	Size	Shape	Cable		Scanning distance (mm)			Element	Min. detectable size (mm)	Model No.	
			Bend radius	Length	Amp	Mode	Distance				
105°C	Straight	Shape E -30 to +105°C	R25	2 m Free cut	HPX-AG	HP	85	190	Receiver and emitter φ1.0	φ0.005	HPF-D013 ^{*1}
						FT	100	55			
						nL	100				
						FT	50				
150°C	Straight	Shape F -60 to +150°C	R35	2 m Free cut	HPX-AG	HP	130	400	Receiver and emitter φ1.5	φ0.005	HPF-D022 ^{*1}
						FT	150	90			
						nL	150	80			
						FT	80				
200°C	Straight	Shape G -30 to +200°C	R15	1 m	HPX-AG	HP	55	170	φ1.4	φ0.005	HPF-D023
						FT	70	42			
						nL	50	50			
						FT	50				
350°C	Straight	Shape H -30 to +350°C	R25	2 m	HPX-AG	HP	75	160	φ1.5	φ0.005	HPF-D015
						FT	85	50			
						nL	90				
						FT	30				

*For scanning distances of the sensing modes, see the Technical Guide (page A-043).

*Scanning distances for diffuse scan are obtained with a standard target object (plain white paper).

*Response times for the sensing types: HP 5 ms, nL 1 ms, and FT 250 μs.

*The values shown in the Minimum detectable size column were obtained with optimal scanning distance and sensitivity settings (HPX-AG).

*1. If a fiber unit is continuously used in an environment where it is at the upper limit of the operating temperature range, the detection distance will decrease. When selecting a fiber unit, be sure to take the ambient temperature into account so that the switch is not continuously operating near its limits.

OUTER DIMENSIONS

(Unit: mm)

●Thru scan

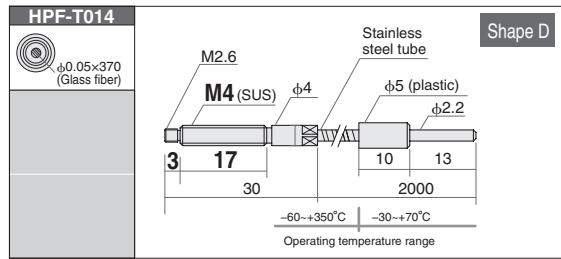
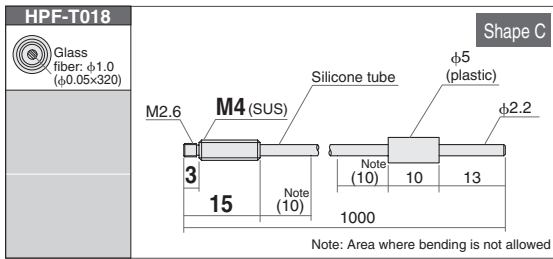
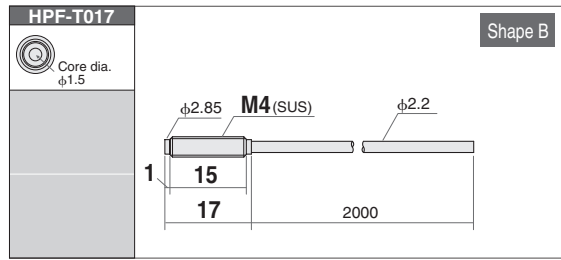
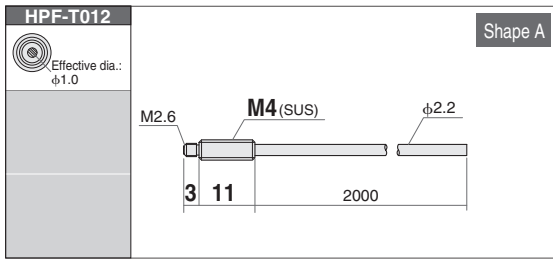

●Diffuse scan

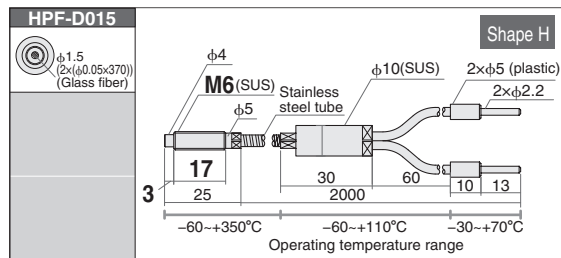
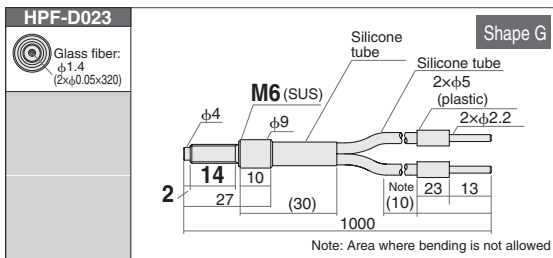
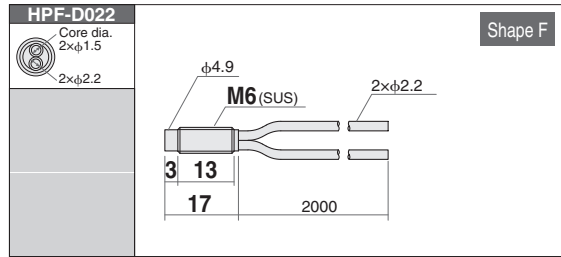
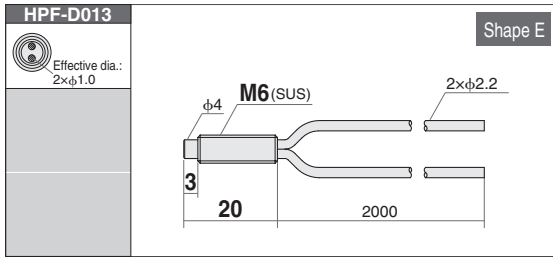

NOTEWORTHY

Use the lens unit appropriate for your application.

*Select a lens with the desired heat resistance.

Heatproof temp.	Lens	Type	Sensitivity
200°C	FE-PA-L1	Long distance	Approx. x6
	FE-PA-S1	Side	-
350°C	HPF-VL06	Long distance	Approx. x10
	HPF-VL05	Side	-

*Compatible lens units P. A-037

Chemical-proof

Protected with PFA tubing for excellent chemical resistance.

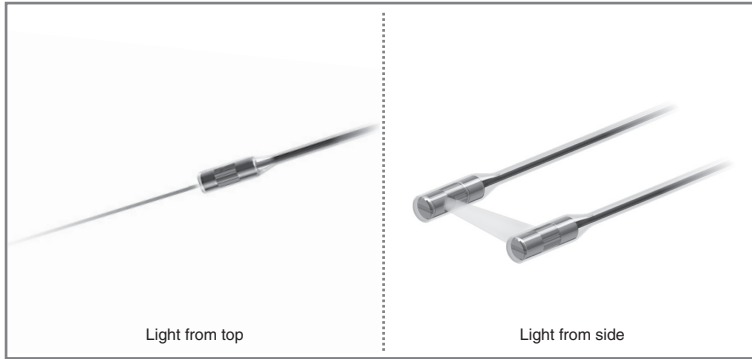

[Related pages]

Wet process switches for level & leak detection

A-033





Usage notes

A-170

OUTER GUIDE

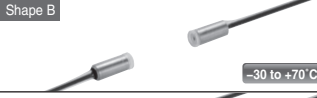
● Thru scan

Light emitter	Size	Shape	Cable		Scanning distance (mm)			Min. detectable size (mm)	Model No.	
			Bend radius	Length	Amp	Mode	Distance			
Top	φ4.7	Shape A  -30 to +70°C	R20	2 m Free cut	HPX-AG	HP	1,310	4,500	φ0.1	HPF-T029
					HPX-EG	nL	880	1,500		
					HPX-H	FT	1,500			
					HPX-A	FT	750			
Top	φ4.7	Shape B  -30 to +70°C	R20	2 m Free cut	HPX-AG	HP	240	825	φ0.1	HPF-T029E
					HPX-EG	nL	280			
					HPX-H	FT	160			
					HPX-A	FT	270			
Side	φ4.7	Shape C  -30 to +70°C	R20	2 m Free cut	HPX-AG	HP	300	1,030	φ0.1	HPF-T035
					HPX-EG	nL	350			
					HPX-H	FT	210			
					HPX-A	FT	340			

● Diffuse scan

Light emitter	Size	Shape	Cable		Scanning distance (mm)			Min. detectable size (mm)	Model No.	
			Bend radius	Length	Amp	Mode	Distance			
Top	φ6	Shape D  -30 to +70°C	PFA area: R80 Cable area: R20	2 m Free cut	HPX-AG	HP	170		-	HPF-D014
					HPX-EG	nL	55			
					HPX-H	FT	70			
					HPX-A	FT	42			

*For scanning distances of the sensing modes, see the Technical Guide (page A-043).

*Scanning distances for diffuse scan are obtained with a standard target object (plain white paper).

*Response times for the sensing types: HP 5 ms, nL 1 ms, and FT 250 μs.

*For chemical resistance of fluorine-resin, see the Technical Guide (page A-039).

*The values shown in the Minimum detectable size column were obtained with optimal scanning distance and sensitivity settings (HPX-AG).

OUTER DIMENSIONS

(Unit: mm)

●Thru scan

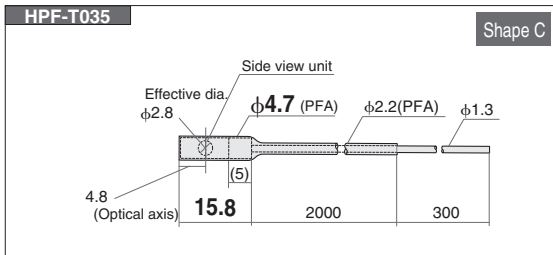
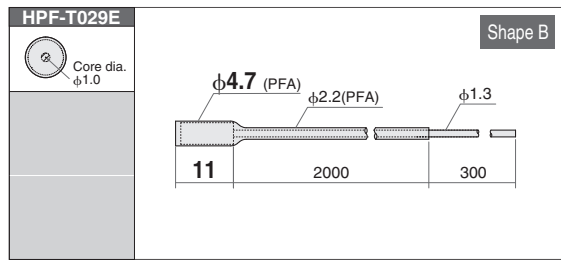
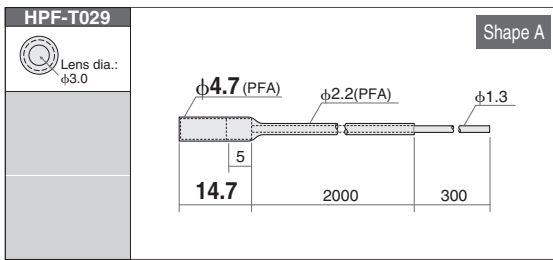

●Diffuse scan

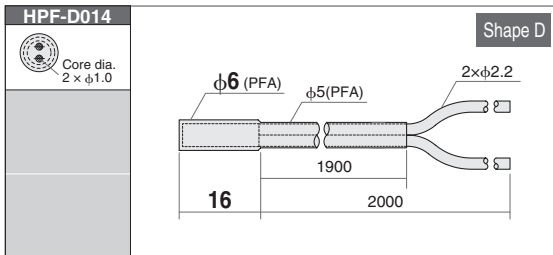

NOTEWORTHY

Installation man-hours greatly reduced

Simply cut the PFA-jacketed cable to length and insert as is into the amplifier.

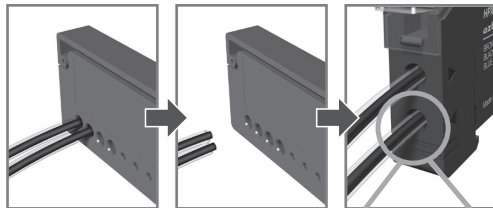

Simply cut the PFA-jacketed cable.

Insert as is into the amplifier. The insertion area requires no PFA working.

Conventionally



PFA tube must be stripped off before inserting fiber.

After improvement



Fiber cut with a cutter can be directly connected to an amplifier.

Saves space



Tube has small outside diameter of 2.2 mm, which can save considerable space compared with previous models. Bend radius is also greatly improved.

Vacuum-proof

Usable in a vacuum. Cable length can be specified.

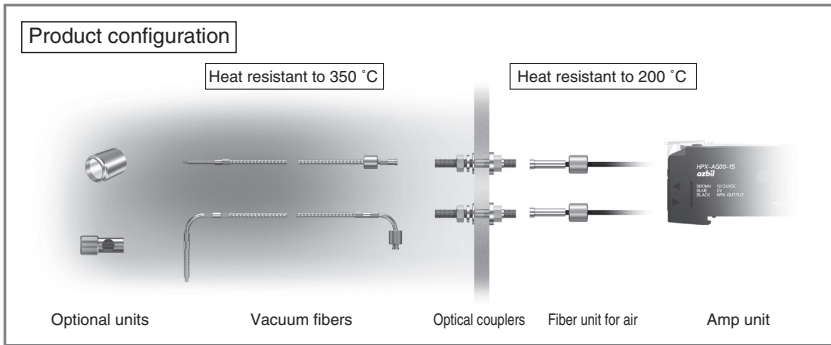

[Related pages]
Usage notes
A-154

CONFIGURATION OF VACUUM FIBER MODEL NUMBERS

HPF -VT 0 S -S1000 (Typical examples)

Base model No.	Model	Head shape	Coupler side shape	Cable length	Description	
HPF	-VT				Thru scan	
	-VD				Diffuse scan	
		0			Straight	
		1			Elbow (VT type only)	
			S		Straight	
			E		Elbow	
				Cable length	Ordering increment	
				-S□□□□	25 mm to 500 mm	25 mm
				-S□□□□	550 mm to 1500 mm	50 mm
				-S□□□□	1600 mm to 5000 mm	100 mm

Cable drawing

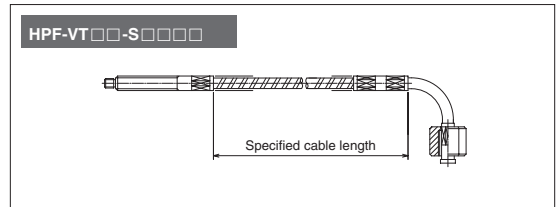
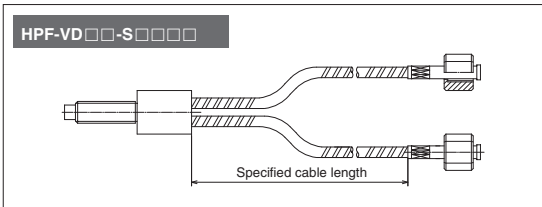

CHART

◇ Scanning distance characteristics

Thru scan

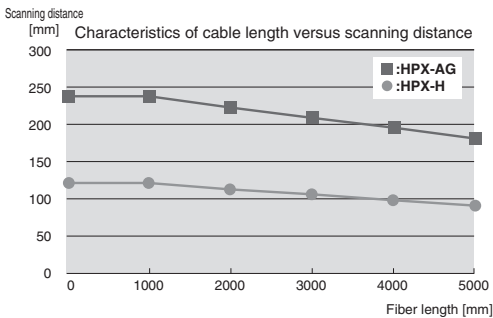

Diffuse scan

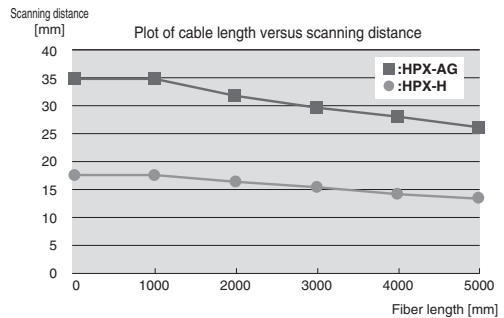

*For fiber units for air, HPF-VA01 is used for calculation.

*Scanning distances for diffuse-scan were obtained using a standard target object (plain white paper).

*For calculations, nL was used as the sensing type for HPX-AG.

OPTIONS FOR VACUUM FIBER UNIT

Product name	Shape	Heatproof	Other specifications	Model No.
Optical coupler (two units)		200°C	-	HPF-VJ03
Fiber unit for air (two units in a pair)		70°C	Cable length: 2 m Bend radius: R20 Free cut	HPF-VA01
		150°C	Cable length: 2 m Bend radius: R35 Free cut	HPF-VA02-B
Long-distance lens unit (two units)		350°C	Scanning distance: x10	HPF-VL06
Side-view unit (two units)		350°C	-	HPF-VL05

OUTER DIMENSIONS

(Unit: mm)

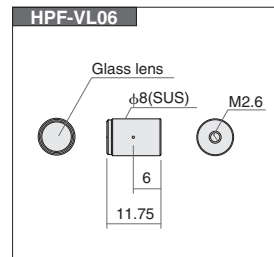
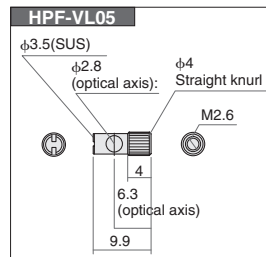
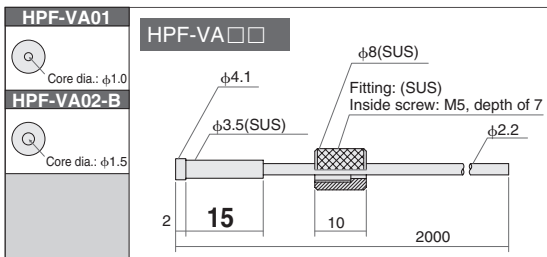
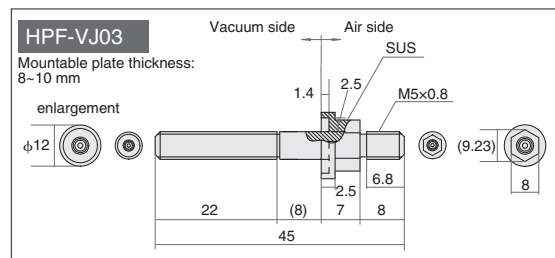
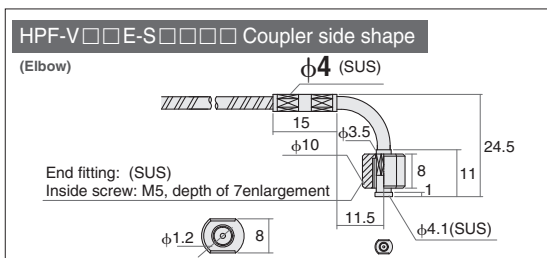
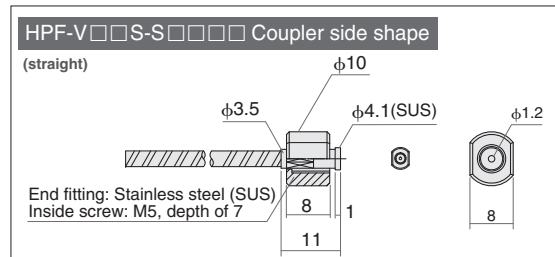
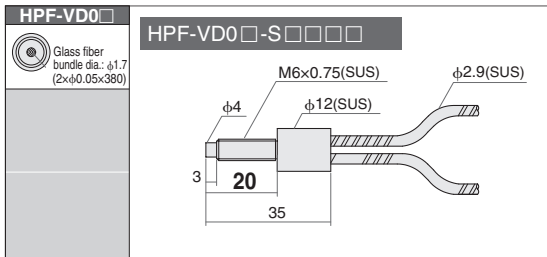
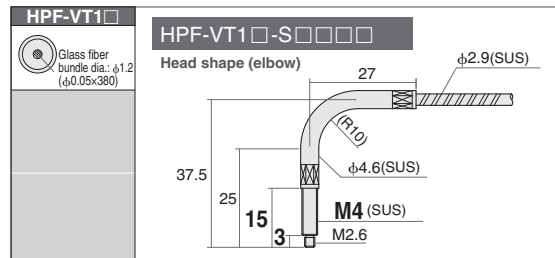
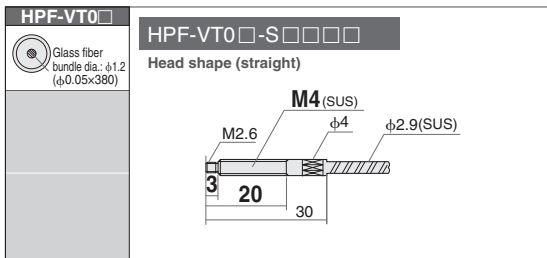

Select by application

Fiber Units for Small Parts Passage Detection

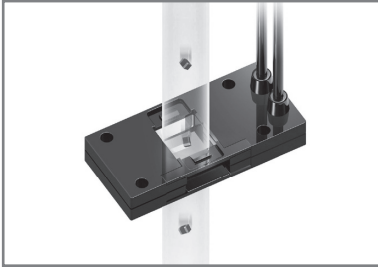

Reliable detection of small parts moving through the pipe.

[Related pages]

A-085

Reliably detects parts in the pipe.

Weighs only 12 g.



For operation inside a moving device, highly bend-tolerant optical fiber cable are used.

Wire lead-out follows the pipe, allowing a smaller footprint.

By changing the attachment, the width of the detection area can be adjusted to match the pipe diameter.

QUICK GUIDE

●Thru scan

Area width	Shape	Cable		Model No.
		Bend radius	Length	
12 mm	 -30 to +70°C	R4	0.5 m	HPF-T047
Mixed fiber unit	 -30 to +70°C	R25	2 m Free cut	HPF-EU02A1

*Area width can be changed with attachments (sold separately).

*Use HPF-T047 in combination with HPF-EU02A1.

*Use HPF-EU02A1 for scanning distances of 50 cm or more.

Contact-Type Liquid Level Fiber Units

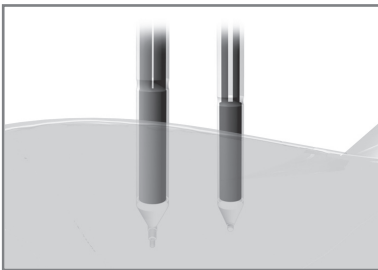

All-resin structure ensures no metal contamination.

[Related pages]



A-077

Problems due to liquid accumulation are reduced by Azbil corporation's innovative front end structure.

Product lineup includes a small-diameter model ($\phi 4$) for easier cable routing.

QUICK GUIDE

●Diffuse scan

Type	Shape	Cable		Model No.
		Bend radius	Length	
$\phi 4$	 -30 to +105°C	PFA area: R30 Cable area: R15	2 m Free cut	HPF-D033
$\phi 6$	 -30 to +105°C	PFA area: R40 Cable area: R25	2 m Free cut	HPF-D027

Pipe-Mounted Liquid Level Fiber Units

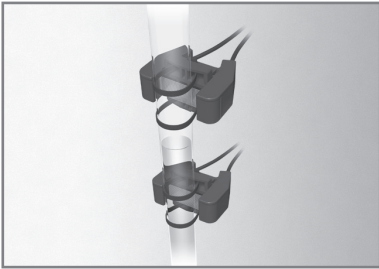



A 16-axis array of light beams greatly eliminates interference from water droplets and air bubbles.

- Product lineup includes differing detection methods for fail-safe detection.
- Can be used for pipe diameters of 3 to 19 mm.

[Related pages]
A-073

● OUDER GUIDE

●Thru scan (Attached to pipe)

Type	Compatible pipe dia.	Shape	Cable			Model No.
			Bend radius	Length	Coating material	
Liquid-absent received light	φ8~φ19 mm (3/4B)	 -30 to +70 °C	R4	5 m Free cut	PFA	HPF-T034
				2 m Free cut	Polyethylene	HPF-T034E
						HPF-T034E-L02
Liquid-present received light	φ3~φ13 mm	 -30 to +70 °C	R4	5 m Free cut	PFA	HPF-T032
				2 m Free cut	Polyethylene	HPF-T032E
						HPF-T032E-L02

Use with PFA transparent pipe with wall thickness of 1 mm.

Depending on the pipe actually used, as well as the liquid thru scan and refractive ratios, fiber unit detection may not be reliable, so be sure to test the operation before use.

If the fiber unit is used with other than the recommended pipe, material, or wall thickness, please test before use or consult our sales staff.

Liquid Leakage Fiber Units



PFA jacket affords outstanding ease of routing.

- Space-saving switch head height of only 9.9 mm
- Can be used in explosion-proof atmospheres because the cable is optical fiber.

[Related pages]
A-083

● OUDER GUIDE

●Diffuse scan

Shape(mm)	Cable		Model No.
	Bend radius	Length	
 -30 to +70 °C	R20	5 m Free cut	HPF-D040

Lens unit Micro-Spot Lens



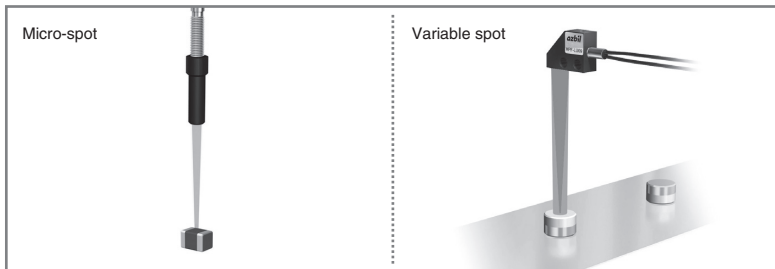







Lens unit achieving a micro-spot by combination with the coaxial type.
Lenses can be selected according to the target object size.



[Related pages]
Compatible fiber units
A-015 (Coaxial)

SELECTION GUIDE

● For diffuse scan type

Type	Shape	Minimum spot dia.	Focus distance	Combined fiber		Model No.		
				Model No.	Spot dia.			
Micro-spot	Shape A  Identification mark -30 to +70°C	Approx. 0.1 mm 	4.6mm ± 0.2mm	HPF-D034 HPF-D010 HPF-D032 HPF-D035	Approx. 0.1 mm Approx. 0.2 mm Approx. 0.2 mm Approx. 0.2 mm	HPF-LU07		
	Shape A  -30 to +70°C	Approx. 0.2 mm 	7.0mm ± 0.5mm	HPF-D034 HPF-D010 HPF-D032 HPF-D035	Approx. 0.2 mm Approx. 0.4 mm Approx. 0.4 mm Approx. 0.4 mm		HPF-LU01	
	Shape B  -30 to +70°C	Approx. 1.0 mm 	19mm ± 1.0mm	HPF-D034 HPF-D010 HPF-D032 HPF-D035	Approx. 0.2 mm Approx. 1.0 mm Approx. 2.0 mm Approx. 0.4 mm			HPF-LU02
	Shape C  -30 to +70°C	Approx. 1.0 mm 	33mm ± 2.0mm	HPF-D038	Approx. 1.0 mm			
Variable spot	Shape D  -30 to +70°C	Approx. 0.4 mm 	Fiber insertion depth: 6mm 7.0mm ± 1.0mm Fiber insertion depth: 9.5mm 10mm ± 1.0mm	HPF-D035C	φ0.4 to 3.5 mm	HPF-LU09		

CHART

◇ Characteristics of distance versus spot dia. (typical example)

HPF-LU01

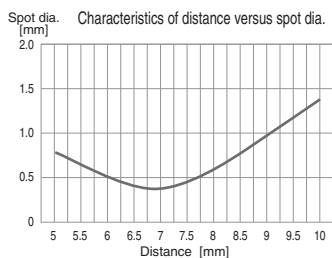

HPF-LU02

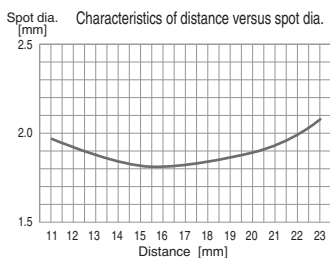

HPF-LU07

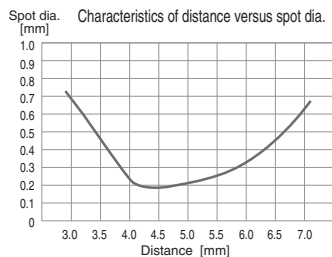

HPF-LU08

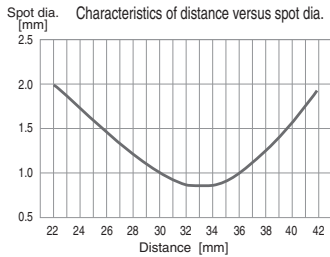

HPF-LU09

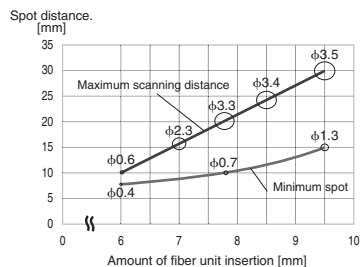

The chart shows the following characteristics in relation to the amount of fiber unit insertion:

- The set distance and spot dia. achieving the minimum spot
- The spot dia. at the maximum scanning distance

*Values are for the lens combined with an HPF-D035 fiber unit. *Measured values are calculated at 13.5% of the peak light level. (Only HPF-LU07 is calculated at 50%.)

OUTER DIMENSIONS

(Unit: mm)

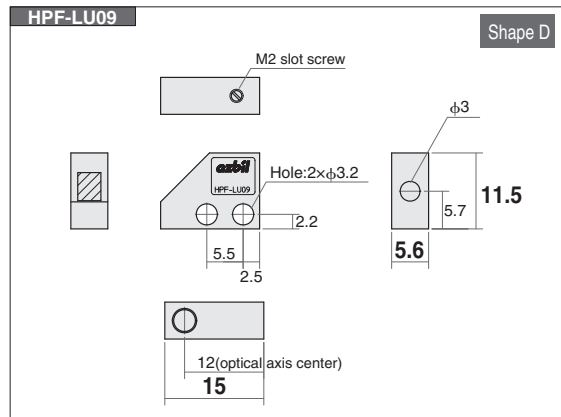
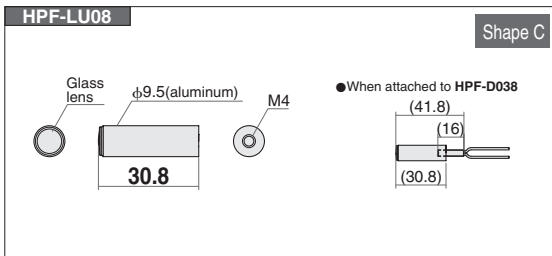
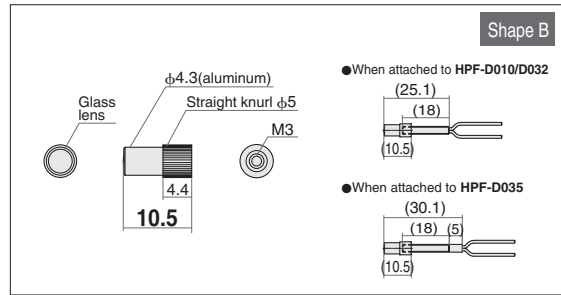
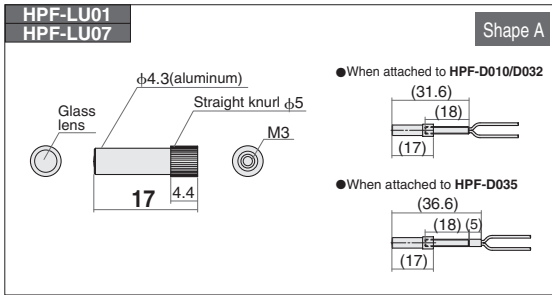

NOTEWORTHY

Improving detection performance yields many positive results

Because of irregular reflection inside a lens, some light is returned even when no workpiece is present, but it is a small amount compared with the light reflected when there is a workpiece.

In **HPF-LU** switches, the internal wall of the lens has a special feature that keeps this internal reflection to a minimum, so there is an increased amount of difference in light level when a workpiece is actually present.

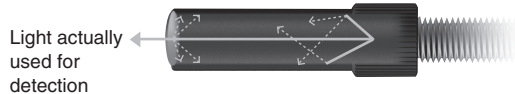

Problems due to scratches on the lens are greatly reduced.

The micro-spot lens is made of hard glass, so problems caused by a drop in light level due to lens scratches made by collisions with workpieces can be greatly reduced.



Lens unit Long-Distance Lens / Side View Unit

Longer distances and alternate optical configurations are available by combination with thru-scan switches.

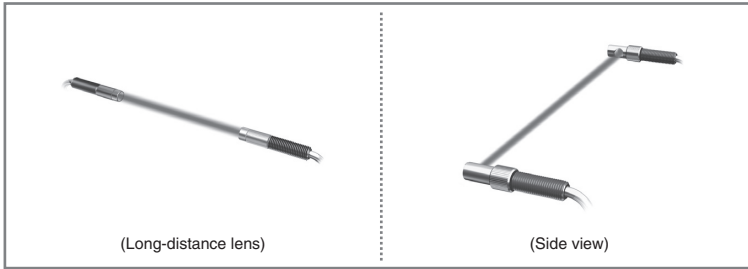

[Related pages]

For combined fibers:

A-009 (screw)





A-013 (cylindrical)

A-027 (heatproof)

A-031 (vacuum proof)

OUTER GUIDE

● For thru scan

Type	Shape	Scaling	Directional angle (half angle)	Fiber unit		Scanning distance (mm)				Model No.
				Model No.	Element type	HPX-AG	HPX-EG	HPX-H	HPX-A	
Long-distance lens	Shape A  (Two units) -40 to +200°C	×6	3°	HPF-T003	Standard	7,200	2,040	2,400	1,200	FE-PA-L1
				HPF-T018	Heatproof	3,690	690	900	600	
				HPF-T024	Unbreakable	840	240	300	150	
Long-distance lens	Shape B  (Two units) -40 to +350°C	×10	3°	HPF-T003	Standard	12,000	3,400	4,000	2,000	HPF-VL06
				HPF-T018	Heatproof	6150	1,150	1,500	1,000	
				HPF-T024	Unbreakable	1,400	410	500	250	
Side view	Shape C  (Two units) -40 to +200°C	-	10°	HPF-T003	Standard	1,200	340	400	200	FE-PA-S1
				HPF-T018	Heatproof	615	115	150	100	
	Shape D  (Two units) -40 to +350°C	-	8°	HPF-T003	Standard	1,200	340	400	200	HPF-VL05
				HPF-T018	Heatproof	615	115	150	100	
				HPF-T024	Unbreakable	140	41	50	25	

The scanning distances shown are nominal values. The actual scanning distances are limited by the fiber length (approx. 2 m × 2 m ≒ 4 m in the case of standard type).

For HPX-AG, the scanning distance shown is for HP mode (response time: 5 ms).

For HPX-EG, the scanning distance shown is for nL mode (response time: 1 ms).

The directional angles shown are typical examples obtained when the lens is combined with an HPF-T003.



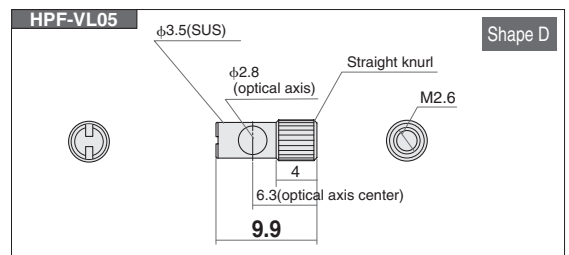
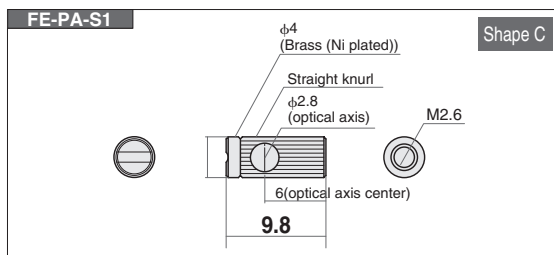
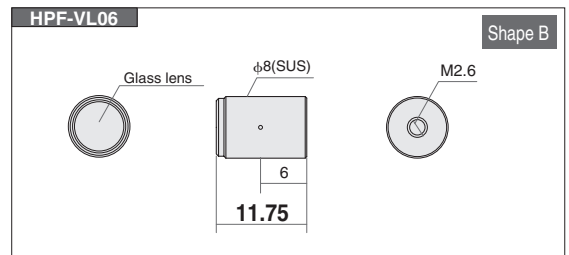
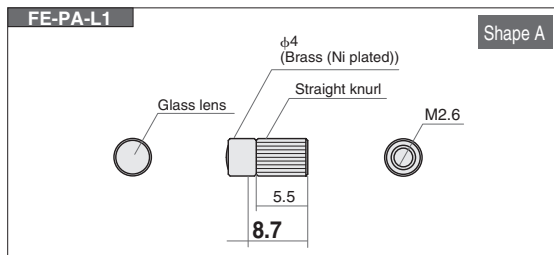

OUTER DIMENSIONS

(Unit: mm)



OTHER ACCESSORIES

Use in combination with various fiber units.

Product name	Shape	Description	Other specifications	Model No.
Angle adjustment bracket		Use with a thru-scan fiber unit to limit reflection, or use as side view type brackets.	Used for M4 and M3 heads, $\phi 4$ and $\phi 3$	HPX-PA06
Fiber-optic extender		Use to extend fibers by linking them. For scanning range see p. A-000.	Cable length: 5 m. Bend: 4 mm in radius Free cut	HPF-EU05
			Cable length: 10 m. Bend: 4 mm in radius Free cut	HPF-EU10
Fiber head bracket		Suitable for attaching a fiber head.	For M3 head	FE-PA-FB1
			For M4 head	FE-PA-FB2
			For M6 head	FE-PA-FB4
Small-diameter attachment (Two units)		Use in combination with small-dia. fiber units. *Supplied with applicable fibers.	For fibers with dia. of $\phi 1.0$	HPF-AT10
			For fibers with dia. of $\phi 1.3$	HPF-AT13
Fiber cutter		Use to cut fibers. *Supplied with applicable fibers.	Used for freehand cuttable fibers	FE-PA-F1

OUTER DIMENSIONS

(Unit: mm)

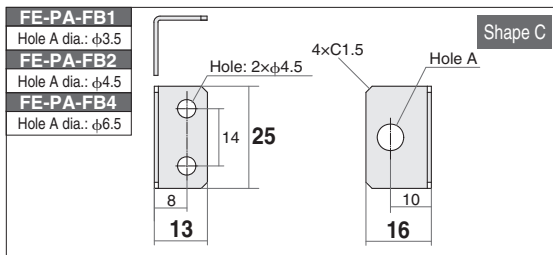
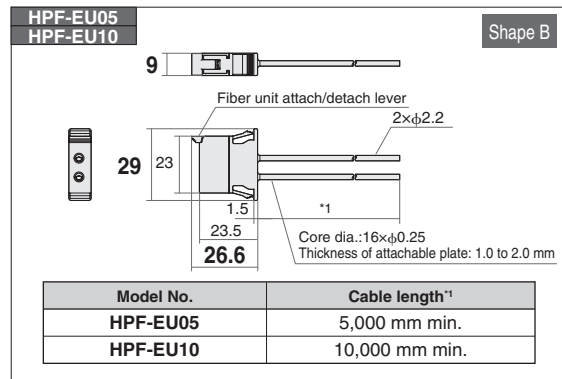
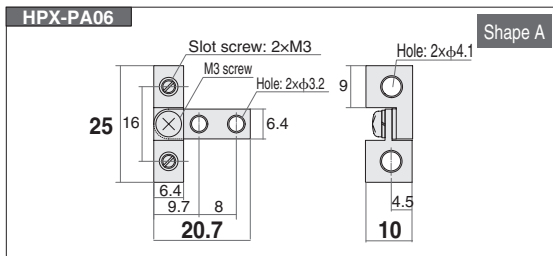

PFA CHEMICAL PROOF

Substance		PFA chemical proof
Heavy oils A/B/C		OK
Aniline	C ₆ H ₅ NH ₂	OK
Acrylonitrile	C ₂ H ₃ CN	OK
Asphalt		OK
Acetone	(CH ₃) ₂ CO	OK
Methanol	CH ₃ OH	OK
Ammonia	NH ₃	OK
Isocetane	i-C ₈ H ₁₈	OK
Isobutyl alcohol	i-C ₄ H ₉ OH	OK
Isobutyl methyl ketone	C ₄ H ₉ COCH ₃	OK
Ethanol	C ₂ H ₅ OH	OK
Ether	(CH ₃) ₂ O	OK
Ethylene glycol	C ₂ H ₄ (OH) ₂	OK
Enamel paint		OK
Ammonium chloride	NH ₄ Cl	OK
Calcium chloride	CaCl ₂	OK
Sodium chloride	NaCl	OK
Barium chloride	BaCl ₂	OK
Chlorine	Cl ₂	OK
Gasoline		OK
Glass ingredients		OK
Dilute hydrochloric acid	HCl	OK
Dilute sodium hydroxide	NaOH	OK
Dilute acetic acid	CH ₃ COOH	OK
Dilute nitric acid	HNO ₃	OK
Dilute sulfuric acid	H ₂ SO ₄	OK
Citric acid	C ₃ H ₄ (OH)(COOH) ₃	OK
Glycerin	C ₃ H ₅ (OH) ₃	OK
Cresol	C ₆ H ₄ (OH)(CH ₃)	OK
Chloroform	CH ₃ Cl	OK

Substance		PFA chemical proof
Light oil		OK
Paraffinum liquidum		OK
Sodium dichromate	Na ₂ Cr ₂ O ₇	OK
Barium nitrate	Ba(NO ₃) ₂	OK
Silicone oil		OK
Plant oil		OK
Thinner		OK
Barium hydroxide	Ba(OH) ₂	OK
Phenol	C ₆ H ₅ OH	OK
Turbine oil		OK
Sodium carbonate	Na ₂ CO ₃	OK
Turpentine		OK
Natural volatile oil		OK
Kerosine petroleum		OK
Trichloroethane	C ₂ H ₃ Cl ₃	OK
Trichlorethylene	C ₂ HCl ₃	OK
Toluene	C ₆ H ₅ CH ₃	OK
Naphtha	C ₇ H ₁₆	OK
Acidum lacticum		OK
Nitrobenzene	C ₆ H ₅ NO ₂	OK
Hydrofluoric acid (hydrogen fluoride)	HF	*
Ferrosilicon		OK
Freon 11	FCCl ₃	OK
Propyl alcohol	C ₃ H ₇ (OH) ₃	OK
Propylene glycol	C ₃ H ₇ (OH) ₂	OK
Benzene	C ₆ H ₆	OK
Methyl violet		OK
Water	H ₂ O	OK
Carbon tetrachloride	CCl ₄	OK
Ammonium sulfate	(NH ₄) ₂ SO ₄	OK

*For information on hydrofluoric acid, contact our sales staff.

Additional Notes

- The above table is not a guarantee that the product can be used with the indicated substance.
- Substances such as strong acids and ammonia may penetrate PFA (fluororesin).

FIBER LENGTH VS. SCANNING DISTANCE CHARACTERISTICS

Note that extending fiber length reduces scanning distance.

◇ Standard fiber element

Element type		Distance change ratio for each element length						
Core dia.	Bend radius	2 m	5 m	10 m	15 m	20 m	25 m	30 m
0.25	R4	100%	62%	28%	12%	Unavailable	Unavailable	Unavailable
0.5	R1	100%	66%	33%	17%	Unavailable	Unavailable	Unavailable
	R15	100%	85%	64%	49%	37%	28%	21%
0.75	R15	100%	85%	64%	49%	37%	28%	21%
1	R2	100%	76%	48%	30%	19%	12%	Unavailable
	R5	100%	50%	16%	Unavailable	Unavailable	Unavailable	Unavailable
	R20	100%	85%	64%	49%	37%	28%	21%

◇ Heatproof fiber element



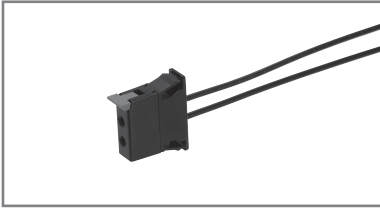

Element type		Distance change ratio for each element length						
Heatproof	1 m	2 m	5 m	10 m	15 m	20 m	25 m	30 m
105°C	-	100%	57%	22%	Unavailable	Unavailable	Unavailable	Unavailable
150°C	-	100%	50%	16%	Unavailable	Unavailable	Unavailable	Unavailable
200°C	100%	93%	76%	54%	38%	27%	19%	13%
350°C	-	100%	81%	58%	41%	29%	20%	14%

Characteristics of Scanning Distance by Combination with Fiber Extender (typical values)







FOUNDER GUIDE

●Thru scan

Type	Model No.	Scanning distance and cable length when combined with fiber extender: HPX-AG (HP mode: 5 ms in response time)*1		
		No extender	HPF-EU05 (5 m)	HPF-EU10 (10 m)
 Standard fiber	HPF-T003 Related pages A-009	1200 mm	580 mm	440 mm
		Cable length:2 m	Cable length:7 m	Cable length:12 m
		100%	49%	37%
 Heatproof	HPF-T018 Related pages A-027	615 mm	250 mm	195 mm
		Cable length:1 m	Cable length:6 m	Cable length:11 m
		100%	42%	32%
 Area	HPF-T021T Related pages A-025	3600 mm	1510 mm	1150 mm
		Cable length:2 m	Cable length:7 m	Cable length:12 m
		100%	42%	32%
 Unbreakable fiber	HPF-T024 Related pages A-009	140 mm	37 mm	28 mm
		Cable length:2 m	Cable length:7 m	Cable length:12 m
		100%	27%	20%
 Pipe-mounted liquid level	HPF-T032 , T032E HPF-T034 , T034E Related pages A-034	Available ²	Available ²	Unavailable
		Cable length:5 m	Cable length:10 m	Cable length:15 m

●Diffuse scan

Type	Model No.	Scanning distance and cable length when combined with fiber extender: HPX-AG (HP mode: 5 ms in response time)*1		
		No extender	HPF-EU05 (5 m)	HPF-EU10 (10 m)
 Standard fiber	HPF-D002 Related pages A-011	400 mm	170 mm	125 mm
		Cable length:2 m	Cable length:7 m	Cable length:12 m
		100%	43%	32%
 Heatproof	HPF-D023 Related pages A-027	170 mm	47 mm	35 mm
		Cable length:1 m	Cable length:6 m	Cable length:11 m
		100%	28%	21%
 Unbreakable fiber	HPF-D029 Related pages A-011	25 mm	8 mm	6 mm
		Cable length:2 m	Cable length:7 m	Cable length:12 m
		100%	33%	25%
 Liquid leakage	HPF-D040 Related pages A-034	Available ²	Available ²	Unavailable
		Cable length:5 m	Cable length:10 m	Cable length:15 m
 Contact liquid level	HPF-D027 Related pages A-033	Available ²	Available ²	Unavailable
		Cable length:5 m	Cable length:10 m	Cable length:15 m

*1 For combinations other than with HPX-AG, please contact us.

*2 Even where availability is indicated, detection may not be possible depending on the liquid. Please check operation before use.

CHARACTERISTICS DIAGRAMS (TYPICAL EXAMPLES)

● Excess gain



HPF-T003

Related pages [A-009](#)

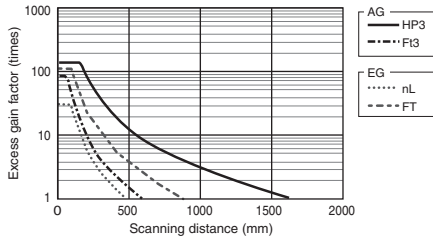

HPF-T003 / FE-PA-L1

Related pages [A-009](#), [A-037](#)

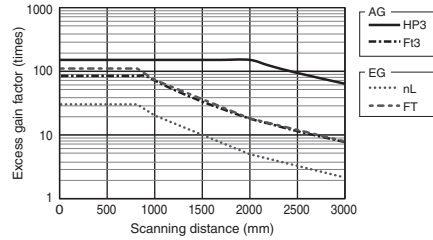

HPF-D002

Related pages [A-011](#)

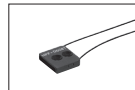
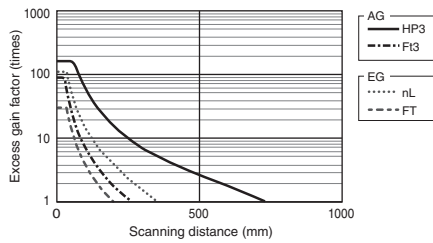

HPF-D028T

Related pages [A-024](#)

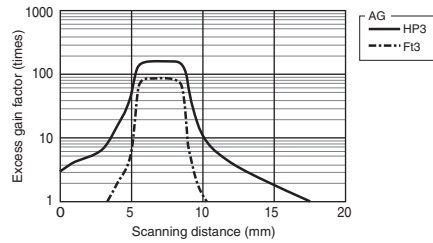

● Parallel displacement



HPF-T003

Related pages [A-009](#)

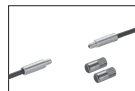
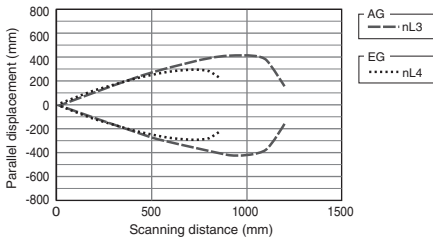

HPF-T003 / FE-PA-L1

Related pages [A-009](#), [A-037](#)

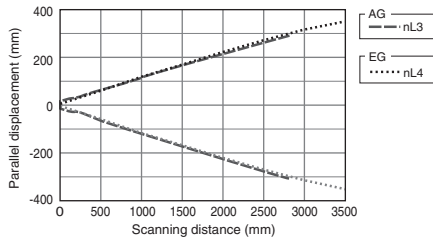

HPF-T021T
(Right and left detection)

Related pages [A-025](#)

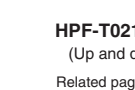
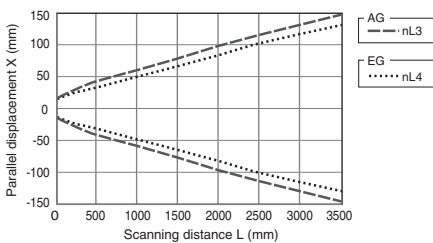
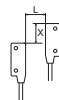

HPF-T021T
(Up and down detection)

Related pages [A-025](#)

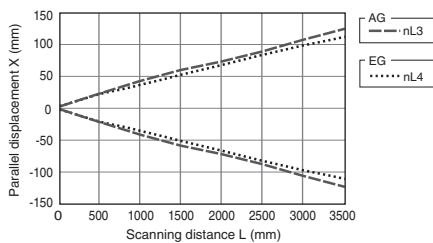
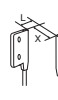



HPF-T029

Related pages **A-029**

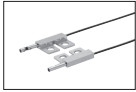
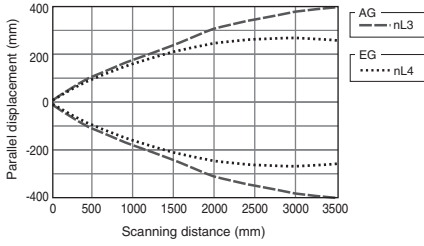

HPF-T030

(Right and left detection)

Related pages **A-021**

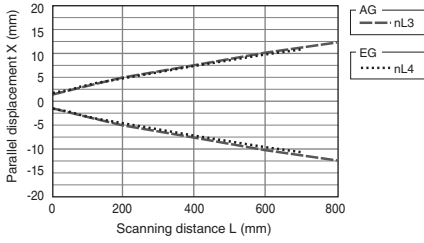
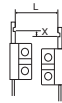

HPF-T030

(Up and down detection)

Related pages **A-021**

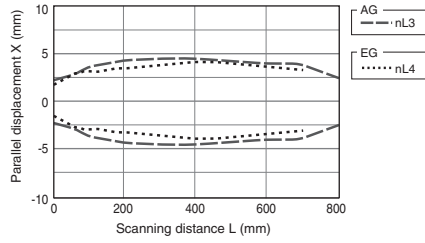

●Detection area characteristics



HPF-D002

Related pages **A-011**

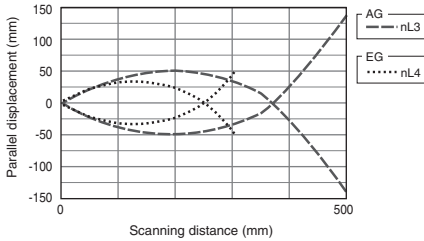

HPF-D025

Related pages **A-021**

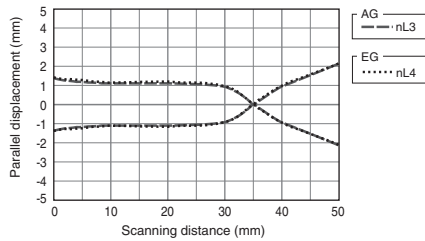

LIST OF SCANNING DISTANCE BY AMPLIFIERS MODEL

●Thru scan



Model No.	Scanning distance (mm)											Page
	HPX-AG						HPX-EG			HPX-H	HPX-A	
	HP	nL	SF	FT	HS	SH	nL	SF	FT	—	—	
HPF-T001	2,175	1,450	1,160	630	360	500	770	650	450	800	400	A-009
HPF-T002	2,175	1,450	1,160	630	360	500	770	650	450	800	400	A-013
HPF-T003	1,200	800	640	350	200	280	410	350	240	400	200	A-009
HPF-T004	1,200	800	640	350	200	280	410	350	240	400	200	A-013
HPF-T005	1,200	800	640	350	200	280	410	350	240	400	200	A-017
HPF-T006	1,200	800	640	350	200	280	410	350	240	400	200	A-017
HPF-T007	165	110	88	48	27	38	55	48	33	60	30	A-019
HPF-T008	180	120	96	52	30	42	60	50	38	100	40	A-009
HPF-T009	180	120	96	52	30	42	60	50	38	100	40	A-013
HPF-T010	855	570	455	245	140	195	300	250	170	300	150	A-009
HPF-T012	690	460	365	200	115	160	240	200	140	250	120	A-027
HPF-T014	660	440	350	190	110	150	220	190	130	250	120	A-027
HPF-T015	37	25	20	10	6	8	12	10	7	12	6	A-017
HPF-T017	1,200	800	640	350	200	280	410	350	240	400	200	A-027
HPF-T018	615	410	325	175	100	140	140	120	80	200	100	A-027
HPF-T019	4,140	2,760	2,200	1,200	690	965	1,400	1,200	840	1,500	750	A-021
HPF-T020	4,500	3,000	2,400	1,310	750	1,050	1,500	1,300	920	1,600	800	A-021
HPF-T021	780	520	415	225	130	180	270	220	160	250	125	A-025
HPF-T021S	3,450	2300	1,840	1,000	575	800	1,100	960	670	1,100	550	A-025
HPF-T021T	3,600	2400	1,920	1,050	600	840	1,200	1,000	710	1,200	600	A-025
HPF-T021WT	3,600	3600	3,200	1,750	1,000	1,400	2,000	1,600	1,100	2,000	1,000	A-025
HPF-T023	3,600	2,400	1,920	1,050	600	840	1,200	1,000	730	1,200	600	A-021
HPF-T024	140	95	75	40	23	33	50	42	29	50	25	A-009
HPF-T025	900	600	480	260	150	210	310	260	180	300	150	A-009
HPF-T025B	900	600	480	260	150	210	310	260	180	300	150	A-009
HPF-T026	52	35	28	15	8	12	20	16	11	20	10	A-019
HPF-T028	140	95	75	40	23	33	50	42	29	50	25	A-023
HPF-T028LF	210	140	110	60	35	49	80	65	47	80	40	A-023
HPF-T029	4,500	3,000	2,400	1,310	750	1,050	1,500	1,200	880	1,500	750	A-029
HPF-T029E	825	550	440	240	135	190	280	230	160	270	130	A-029
HPF-T030	500	500	500	305	175	245	310	260	180	350	175	A-021
HPF-T031	900	600	480	260	150	210	310	260	180	300	150	A-013
HPF-T032	—	—	—	—	—	—	—	—	—	—	—	A-034
HPF-T032E	—	—	—	—	—	—	—	—	—	—	—	A-034
HPF-T033	900	600	480	260	150	210	280	240	160	265	130	A-009
HPF-T034	—	—	—	—	—	—	—	—	—	—	—	A-034
HPF-T034E	—	—	—	—	—	—	—	—	—	—	—	A-034
HPF-T035	1,030	690	550	300	170	240	350	300	210	340	170	A-029
HPF-T036	18	12	9	5	3	4	6	5	3	6	3	A-013
HPF-T037	52	35	28	15	8	12	20	16	11	20	10	A-019
HPF-T038	37	25	20	10	6	8	12	10	7	12	6	A-013
HPF-T039	18	12	9	5	3	4	5	4	3	6	3	A-017
HPF-T042	660	440	350	190	110	150	220	190	130	240	120	A-019
HPF-T043	300	200	160	85	50	70	100	80	55	100	50	A-013
HPF-T044	675	450	360	195	110	155	220	190	130	220	110	A-009
HPF-T046	180	120	96	52	30	42	60	50	38	100	40	A-013
HPF-T047	—	—	—	—	—	—	—	—	—	—	—	A-033
HPF-T054-L05	6	6	6	6	6	6	6	6	6	6	6	A-023

LIST OF SCANNING DISTANCE BY AMPLIFIERS MODEL

● Diffuse scan



Model No.	Scanning distance (mm)											Page
	HPX-AG						HPX-EG			HPX-H	HPX-A	
	HP	nL	SF	FT	HS	SH	nL	SF	FT	—	—	
HPF-D001	530	400	320	170	85	130	210	180	120	230	120	A-011
HPF-D002	400	300	240	130	65	100	150	130	90	150	80	A-011
HPF-D003	400	300	240	130	65	100	150	130	90	150	80	A-017
HPF-D004	105	80	64	34	17	26	43	36	25	40	20	A-011
HPF-D005	105	80	64	34	17	26	43	36	25	40	20	A-013
HPF-D006	105	80	64	34	17	26	43	36	25	40	20	A-017
HPF-D009	400	300	240	130	65	100	150	130	90	150	80	A-015
HPF-D010	86	65	52	28	14	21	35	30	21	40	20	A-015
HPF-D011	40	30	24	13	6	10	17	14	10	15	8	A-019
HPF-D012	250	190	150	80	40	60	100	80	55	100	50	A-011
HPF-D013	190	190	160	85	43	65	100	80	55	100	50	A-027
HPF-D014	170	130	100	55	28	43	70	60	42	50	50	A-029
HPF-D015	160	160	140	75	39	60	85	70	50	90	30	A-027
HPF-D018	200	150	120	65	32	50	75	65	46	80	40	A-011
HPF-D019	20	16	12	6	2	4	4	3	2	4	2	A-017
HPF-D021	86	65	52	28	14	21	35	30	21	40	20	A-017
HPF-D022	400	300	240	130	65	100	150	130	90	150	80	A-027
HPF-D023	170	130	100	55	28	43	70	60	42	50	50	A-027
HPF-D025	20	20	20	20	20	20	20	20	16	20	20	A-021
HPF-D026	265	200	160	85	43	65	100	90	60	100	50	A-025
HPF-D027	—	—	—	—	—	—	—	—	—	—	—	A-033
HPF-D028	2.5±0.5	2.5±0.5	2.5±0.5	2.5±0.5	—	—	—	—	—	2.5±0.5	2.5±0.5	A-024
HPF-D028F	5.2±1.6	5.2±1.6	5.2±1.6	—	—	—	5.2±1.0	—	—	—	—	A-024
HPF-D028T	7.4±1.6	7.4±1.6	7.4±1.6	—	—	—	7.4±1.2	—	—	—	—	A-024
HPF-D029	25	19	15	8	4	6	10	8	5	10	5	A-011
HPF-D030	210	160	125	69	34	53	85	70	50	80	40	A-011
HPF-D032	46	35	28	15	7	11	18	15	10	18	10	A-015
HPF-D032B	46	35	28	15	7	11	18	15	10	18	10	A-015
HPF-D033	—	—	—	—	—	—	—	—	—	—	—	A-033
HPF-D034	60	45	36	19	9	15	25	21	15	25	13	A-015
HPF-D035	95	95	80	43	21	33	50	42	29	50	25	A-015
HPF-D035C	95	95	80	43	21	33	50	42	29	50	25	A-015
HPF-D036	20	15	12	6	3	5	8	7	5	8	4	A-013
HPF-D037	20	15	12	6	3	5	8	7	5	8	4	A-011
HPF-D038	95	95	80	43	21	33	50	42	29	50	25	A-015
HPF-D039	20	16	12	6	2	4	4	3	2	4	2	A-017
HPF-D040	—	—	—	—	—	—	—	—	—	—	—	A-034
HPF-D041	40	30	24	13	6	10	17	14	10	15	8	A-019
HPF-D042	86	65	52	28	14	21	35	30	21	40	20	A-015
HPF-D043	160	120	96	52	25	40	65	55	40	50	32	A-019
HPF-D045LF	93	70	56	30	15	23	37	31	21	35	17	A-023
HPF-D049	160	120	100	55	27	42	60	55	38	60	34	A-015

Before use, thoroughly read the “Precautions for use” and “Precautions for handling” in the Technical Guide on pages A-141 to A-156 as well as the instruction manual and product specification for this switch.