

Bulletin 800H Hazardous Location Push Buttons

Our Bulletin 800H Type 7 and 9 Hazardous Location Push Buttons offer unmatched selection, excellent corrosion resistance, and choice of conduit seal-off solutions. You can order them as complete factory-assembled stations or as separate components with standard or long barrels.

Application

When properly mounted in a Type 7 and 9 enclosure, Bulletin 800H Type 7 and 9 operators are designed to meet the requirements of the National Electrical Code for Class I, Divisions 1 & 2, Groups B, C, and D Hazardous Gas; Class II, Divisions 1 & 2, Groups E, F, and G Hazardous Dust; and, Class III Hazardous Fiber Locations. In addition, the single-gang shallow base, catalog number 800H-IHZX7, meets Class I, Group B requirements. This Type 7 and 9 equipment is listed by Underwriters Laboratories, Inc.

Per National Electrical Code:

Zone	Description
1	In Class I, Zone 1 locations, all wiring methods that are permitted for Class I, Division 1 locations and Class I, Zone 0 or Zone 1 locations, including requirements for sealing, shall be permitted.
2	In Class I, Zone 2 locations, all wiring methods that are permitted for Class I, Division 2, Class I, Division 1 or Division 2, and Class I, Zone 0 or Zone 1 locations, including requirements for sealing, shall be permitted.

Operator Construction

The Allen-Bradley® line of hazardous location devices features copper-free (less than 0.4 of 1% copper content) die-cast aluminum bushings and mounting rings, type #316 stainless steel operating shafts and an O-ring seal for added corrosion resistance. These components mount into a threaded hole (3/4 in.-14 NPSM) in a suitable enclosure.

Bulletin 800H Type 7 and 9 components are available in two basic formats: standard barrel (Bulletin 800H) and long barrel (Bulletin 800HL). Standard barrel devices are suitable for mounting in panel thickness up to 25.4 mm (1 in.) thick. Long barrel devices are suitable for mounting in panel thickness greater than 25.4 mm (1 in.) and no thicker than 63.5 mm (2.5 in.). Both style operators offer a unique locking bracket, which provides an anti-turn feature to help prevent the operator from coming loose.

The mounting rings in front of the panel are knurled to provide a second way to tighten each unit into the panel.

Outdoor Use

Bulletin 800H Type 7 and 9 stations and enclosures are not configured for outdoor use as standard. A Type 3 rating is available, while maintaining Type 7 and 9 integrity of the enclosure, by the addition of a Type 3 sealing flange and an approved drain. The sealing flange that is shown in [Figure 1](#) can be purchased as an option or as an accessory. A Type 4 rating can be achieved by using sealing nuts to seal the push button operators along with the sealing flange. Sealing nuts are available as accessories (see <https://ab.rockwellautomation.com/Push-Buttons/Hazardous-Location/800H-Push-Buttons#selection>).

Elimination of Conduit Seal Off Requirement

Bulletin 800H Type 7 and 9 units can be installed with various sealing options. By using a flanged sealing well, these stations can be installed without a conduit seal off in most applications (subject to applicable codes and laws). The sealing wells that are shown in [Figure 1](#) can be purchased as an option or as an accessory. Sealing wells have an integral Type 3 flange seal for outdoor applications.

Sealed switch contact blocks are another way to help eliminate the need for conduit seal fittings in most applications (subject to applicable codes and laws). Sealed switch contact blocks can be purchased as an option on assembled stations by changing the Bulletin No. from 800H to 800R. Sealed switch contact blocks can be ordered as an accessory (see <https://ab.rockwellautomation.com/Push-Buttons/Hazardous-Location/800H-Push-Buttons#selection>). A push button station with a sealed switch contact block is shown in [Figure 1](#).

Figure 1 - Sealing Options

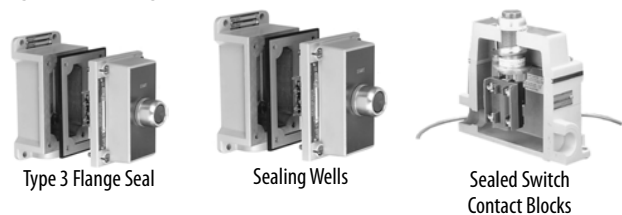

Specifications



ATTENTION: Performance data that is given in this publication is provided only as a guide for you to determine suitability and does not constitute a performance warranty of any kind. Such data may represent the results of accelerated testing at elevated stress levels, and you are responsible for correlating the data to actual application requirements. ALL WARRANTIES AS TO ACTUAL PERFORMANCE, WHETHER EXPRESS OR IMPLIED, ARE EXPRESSLY DISCLAIMED.

Table 1 - Electrical Ratings

Contact Ratings	See the contact ratings on page 5 .
Dielectric Strength	2200V for 1 minute, 1300V for 1 minute (Logic Reed)
Electrical Design Lifecycles	1,000,000 at max rated load, 200,000 at max rated load (Logic Reed)

Table 2 - Mechanical Ratings

Vibration	10...2000 Hz 1.52 mm displacement (peak-to-peak) max/10 G max (except Logic Reed)	
Shock	1/2 cycle sine-wave for 11 ms \geq 25 G (contact fragility) and no damage at 100 G	
Degree of Protection	Type 7 and 9 Explosion Proof (Type 3 and Type 4 ratings available with accessories)	
Mechanical Design Lifecycles	Push Buttons	250,000 min
	Potentiometers	100,000 min
	All other devices	200,000 min
Contact Operation	Shallow and mini contact blocks: slow double make and break Logic Reed and sealed switch contact blocks: snap action	
Wire Gauge/Terminal Screw Torque	#18...14 AWG/6...8 lb-in	
Typical Operating Forces		
Operators without contact blocks:	Flush, extended, standard mushroom, jumbo mushroom	2.9 lb max
	Jumbo and extended aluminum mushroom head	3.95 lb max
	Maintained selector switch	4.0 in-lb max
Spring-return Selector Switches	5 in-lb to stop, 0.2 in-lb to return	
Illuminated Push Buttons and Push-to-test Pilot Lights	5.6 lb max	
2-position Push-Pull	9 lb max push or pull	
3-position Push-Pull	12 lb max push to in position or pull to center position (15 lb max pull to out position)	
Contact Blocks	800T-XA	1 lb
	Logic Reed	1 lb max
	Sealed Switch	3 lb max at 0.205 in. plunger travel
	Stackable Sealed Switch	1 lb max

Table 3 - Environmental

Temperature Range ⁽¹⁾	Operating	-20...+55 °C (-4...+13 °F)
	Storage	-40...+85 °C (-40...+185 °F)
Humidity	50% at 40 °C (104 °F)	

(1) Operating temperatures below freezing are based on the absence of freezing moisture and liquids.

Standard Contact Ratings

Maximum thermal continuous current I_{th} 10 A AC/2.5 A DC. [Table 4](#) shows the ratings for Bulletin 800H Type 7 & 9 units with catalog number 800T-XA contacts.

Table 4 - Standard Contact Ratings

Max Operational Volts U_e	Utilization Category		Rated Operational Currents		
	IEC	NEMA	Volts U_e	Make	Break
AC 600	AC-15	A600	120...600	7200VA	720VA
			72...120	60 A	720VA
			24...28 ⁽¹⁾	60 A	10 A
DC 600	DC-13	Q600	28...600	69VA	
			24...28 ⁽¹⁾	2.5 A	

(1) For applications below 24V and 24 mA, PentUFF™, Logic Reed, or stackable sealed switch contacts are recommended.

Sealed Switch Contact Ratings

Maximum continuous current I_{th} 5 A.

Table 5 - Sealed Switch Contact Ratings

Max Operational Volts U_e	Utilization Category		Rated Operational Currents		
	IEC	NEMA	Volts U_e	Make	Break
AC 600	AC-15	B600	120...600	3600VA	360VA
			0...120	30 A	3 A
DC 300	DC-13	P300	24...300	138VA	
			0...28	5.0 A	

Stackable Sealed Switch Contact Ratings

Maximum continuous current I_{th} 3 A. Bulletin 800T units have control circuit ratings with sealed switch contact blocks as shown in [Table 6](#).

Table 6 - Stackable Sealed Switch Contact Ratings

Max Operational Volts U_e	Utilization Category		Rated Operational Currents		
	IEC	NEMA	Volts U_e	Make	Break
AC 300	AC-15	C300	120...300	1800VA	180VA
			0...120	15 A	1.5 A
DC 150	DC-13	Q150	24...150	69VA	
			0...24	2.5 A	

Logic Reed Contact Ratings

Maximum: 150V AC, 0.15 A, 8VA and 30V DC, 0.06 A, 1.8VA.

Use only with resistive loads.

PentUFF (Low Voltage) Contact Ratings

Minimum DC: 5V, 1 mA

Maximum thermal continuous current I_{th} 2.5 A AC/ 1.0 A DC.

[Table 7](#) shows the ratings for Bulletin 800H units with catalog number 800T-XAV contacts.

Table 7 - PentUFF™ (Low Voltage) Contact Ratings

Max Operational Volts U_e	Utilization Category		Rated Operational Currents		
	IEC	NEMA	Volts U_e	Make	Break
AC 300	AC-15	C300	120...300	1800VA	180VA
			0...120	15 A	1.5 A
DC 150	DC-13	R150	24...150	28VA	
			0...24	1.0 A	

Standards Compliance

- UL508
- UL698
- UL1203
- UL1604
- CSA C22.2 No. 14
- CSA C22.2 No. 25
- CSA C22.2 No. 30

Certifications

Enclosures:











- UL Listed (File No. E71673 Guide No. NNNY)
- CSA (File No. LR11924)

Devices:

- UL Listed (File No. E10314 Guide No. NOIV)
- CSA (File No. LR11924)

Complete Assembled Stations

IMPORTANT Supplied with 19.05 mm (3/4 in.) dead end conduit entry (Cat. No. 800H-1HZX7)

	Operator	Contact Symbol		Contact Action	Legend Marking	Lever Type Actuator	Component Type Buttons
						Cat. No. ⁽¹⁾ ⁽²⁾	Cat. No. ⁽²⁾ ⁽³⁾
 Cat. No. 800H-1HA7	One Push Button		1 N.O. 1 N.C.	Momentary	STOP	800H-1HA7	800H-1HA7P
					START	800H-1HB7	800H-1HB7P
					JOG	800H-1HJ7	800H-1HJ7P
					No Legends	800H-1HX7	800H-1HX7P
 Cat. No. 800H-2HA7P	Two Push Buttons		1 N.O. 1 N.C. Each Button	Momentary	START STOP	800H-2HA7	800H-2HA7P
					FOR REV	800H-2HB7	800H-2HB7P
					RAISE LOWER	800H-2HD7	800H-2HD7P
					OPEN CLOSE	800H-2HF7	800H-2HF7P
					No Legends	800H-2HX7	800H-2HX7P
 Cat. No. 800H-2HAM7	2-position Selector Switch		1 N.O. 1 N.C.	Maintained	START STOP	800H-2HAM7	—
					ON OFF	800H-2HCM7	800H-2HC7
					OPEN CLOSE	800H-2HGM7	800H-2HG7
					RUN STOP	800H-2HJM7	—
					HAND AUTO	800H-2HLM7	800H-2HA7
					No Legends	800H-2HXM7	800H-2HX7
 Cat. No. 800H-R3HA7	3-position Selector Switch		1 N.O. 1 N.C.	—	HAND OFF AUTO	—	800H-R3HA7
					No Legends	—	800H-R3HX7
 Cat. No. 800H-2HAD10R7	One Pilot Light, Dual Push Buttons		120V AC/DC Full Volt./Red	—	START STOP	—	800H-2HAD10R7
			1 N.O. 1 N.C.		Marking other than listed - consult your local Allen-Bradley distributor	—	800H-2HXD10R7

(1) Operators have integral padlocking attachment.

(2) Supplied with standard shallow contact blocks. For stations with sealed switch contacts, change Bulletin number from 800H to 800R. A deep enclosure is required.

(3) STOP is extended red, START is flush green, all others are flush black.

Momentary Contact Push Buttons Units

Non-illuminated Momentary Contact Push Button Units



Flush Head Unit
Cat. No. 800H-AP1A



Extended Head Unit
Cat. No. 800H-BP6B



Mushroom Head Unit
Cat. No. 800H-DP6A

800 H - AP 1 A
 a b c d e

a	
Barrel Type	
Code	Description
H	Standard barrel
HL	Long barrel

b	
Operator Type	
Code	Description
AP	Flush head
BP	Extended head
DP	Mushroom head
DPX	Mushroom head (less color cap)

c	
Color Cap	
Code	Description
Blank	Used only when operator type Code DPX (Table b) is ordered
1	Green
2	Black
3	Orange
4	Gray
6	Red
7	Blue
9	Yellow

d	
Special Mushroom Head ⁽¹⁾	
Code	Description
Blank	No special head
J	Jumbo mushroom head — plastic
L	Jumbo mushroom head — metal

e	
Contact Blocks ⁽²⁾	
Code	Description
Standard	
Blank	No contacts
D1	1 N.O.
D2	1 N.C.
D5	1 N.O. (Mini)
D6	1 N.C. (Mini)
A2	2 N.O.
A4	2 N.C.
A	1 N.O. - 1 N.C.
B	2 N.O. - 2 N.C.
H	3 N.O. - 3 N.C.
C	4 N.O. - 4 N.C.

e, continued	
Contact Blocks ⁽²⁾	
Code	Description
PenTUFF™ (Low Voltage)	
D1V	1 N.O.
D2V	1 N.C.
AV	1 N.O. - 1 N.C.
BV	2 N.O. - 2 N.C.
HV	3 N.O. - 3 N.C.
CV	4 N.O. - 4 N.C.

(1) Special mushroom head options only apply to mushroom head operator type code DP (Table b).

(2) For sealed switch and Logic Reed contact blocks, consult your local Rockwell Automation sales office or Allen-Bradley distributor.

3-position, Non-illuminated



3-Position Push-Pull
Cat. No. 800H-FPXM6A7

800 H - FPX M 1 A7
 a b c d e f

a	
Barrel Type	
Code	Description
H	Standard barrel
HL	Long barrel

b	
Operator Type	
Code	Description
FPX	Push-pull unit

c	
Head Type	
Code	Description
Blank	Mushroom head
J	Jumbo mushroom head ⁽¹⁾

(1) Not valid with color cap option code Blank (Table e)

d			
Operator Function			
Code	Operator Position		
	Out	Center	In
M	Momentary	Maintained	Maintained
N	Momentary	Maintained	Momentary

e	
Color Cap	
Code	Description
Blank	No cap
1	Green
2	Black
4	Gray (silver)
6	Red
7	Blue
9	Yellow (gold)

f				
Contact Blocks				
Code	Operator Position ⁽¹⁾			Description
	Out	Center	In	
Standard				
Blank	—		—	No contacts
A	0 X	0 0	X 0	1 N.O. - 1 N.C.
A1	0 X	0 X	X 0	1 N.O. - 1 N.C.L.B.
A7	X X	0 X	0 0	1 N.C. - 1 N.C.L.B.
B6	X X	0 0	X 0	2 N.C. - 2 N.C.L.B.
PenTUFF (Low Voltage)				
AV	0 X	0 0	X 0	1 N.O. - 1 N.C.

(1) X = Closed/0 = Open

2- and 3-position, Illuminated

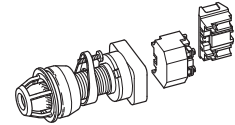

800 H — FPX PH 16 M A1
 a b c d e f g

a	
Barrel Type	
Code	Description
H	Standard barrel
HL	Long barrel

b	
Operator Type	
Code	Description
FPX	Push-pull unit

c	
Operator Function	
Code	Description
2-position	
Blank	Push-pull

c, continued			
Operator Function			
Code	Operator Position		
3-position			
	Out	Center	In
M	Momentary	Maintained	Maintained
N	Momentary	Maintained	Momentary

d	
Illumination Options	
Code	Description
Transformer	
P	Incandescent
PH	LED
Full Voltage	
Q	Incandescent
QH	Universal LED
Dual-input	
D	Dual-input — diode ⁽³⁾
DT	Dual-input — transformer relay
DTH	Dual-input transformer — relay LED

e	
Voltage	
Code	Description
Transformer	
16	120V AC, 50/60 Hz
26	240V AC, 50/60 Hz
46	480V AC, 50/60 Hz
56	600V AC, 50/60 Hz
Full Voltage — Incandescent	
24	24V AC/DC
10	120V AC/DC
20	240V AC/DC
Universal — LED	
2	12...130V AC/DC
Dual-input	
16	120V AC
24	24V AC/DC ⁽⁴⁾

f	
Color Cap	
Code	Description
Blank	No lens with no contacts
X	No lens with contacts
M	Multi-color ⁽²⁾

g	
Contact Blocks	
Code	Description
Standard	
Blank	No contacts
D1	1 N.O.
D4	1 N.C.L.B. ⁽¹⁾
A	1 N.O. - 1 N.C.
A1	1 N.O. - 1 N.C.L.B. ⁽¹⁾
A2	2 N.O.
A5	2 N.C.L.B.
A7	1 N.C. - 1 N.C.L.B. ⁽¹⁾

g, continued	
Contact Blocks	
Code	Description
PenTUFF Low Voltage	
D1V	1 N.O.
D2V	1 N.C.
AV	1 N.O. - 1 N.C.
Logic Reed	
D1R	1 N.O.
D2R	1 N.C.
AR	1 N.O. - 1 N.C.
A2R	2 N.O.
A4R	2 N.C.

- (1) Normally closed late break contact. When button is pushed from the OUT to the IN position, the mechanical detent action of the operator occurs before electrical contacts change state. When the button is pulled from the IN to the OUT position, the electrical contacts change state before the mechanical detent occurs.
- (2) Multi-color insert packet includes amber, blue, green, red, and white.
- (3) Diode type dual-input provides circuit isolation via opposing diodes. Not recommended for use with solid-state outputs and neon indicators.
- (4) Dual-input diode only.

Table 8 - Target Selection

2-position ⁽¹⁾			Contact Description	3-position ⁽¹⁾			g Code
g Code							
A, AV, R	0 X	X 0	N.O. N.C.	0 X	0 0	X 0	A, AV, AR
A1	0 X	X 0	N.O. N.C.L.B.	0 X	0 X	X 0	A1
A2	0 X	0 X	N.O. N.O.	— —	— —	— —	—
A5	X 0	X 0	N.C.L.B. N.C.L.B.	— —	— —	— —	—
—	— —	— —	N.C. N.C.L.B.	X X	0 X	0 0	A7
D1, D1V, D1R	0	X	N.O.	—	—	—	—
D4	X	0	N.C.L.B.	—	—	—	—

(1) X = Closed/O = Open

Selector Switch Units

2-position, Non-illuminated



Standard Knob Operator
Cat. No. 800H-HP2KB6AXXX



Knob Lever Operator
Cat. No. 800H-HP17KB6AXXX



Metal Wing Lever Operator
Cat. No. 800H-HP11KB6AXXX

800	H	—	HP	A	2	KB6	AXXX	(Knob/Wing Lever)
	a		b	c	d	e	f	
800	H	—	HP	31		KB6	AXXX	(Cylinder Lock)
	a		b	c ₁	d ₁	e	f	

a	
Barrel Type	
Code	Description
H	Standard barrel
HL	Long barrel

b	
Number of Positions	
Code	Description
HP	2-position

c	
Knob Insert Colors ⁽¹⁾	
Code	Description
Blank	White
X	Packet of colored inserts ⁽²⁾
Metal Wing Lever Colors	
A	Red
Blank	Gray

c ₁	
Key Removal Position	
Code	Description
Maintained	
31	Key removal — left
32	Key removal — right
33	Key removal — both
Spring Return from Left	
42	Key removal — right ⁽³⁾
Spring Return from Right	
48	Key removal — left

d	
Operator Type and Function	
Code	Description
Standard Knob	
2	Maintained
4	Spring return from left ⁽³⁾
5	Spring return from right
Knob Lever	
17	Maintained
18	Spring return from left ⁽³⁾
19	Spring return from right
Metal Wing Lever	
11	Maintained
15	Spring return from left ⁽³⁾
16	Spring return from right

- (1) Each standard and knob lever operator is factory-assembled with a white insert. Other colors are available, factory-assembled, if ordered in quantities of 10 or more.
- (2) One insert of each color (blue, green, orange, red, and yellow).
- (3) Target tables are reversed.

d ₁			
Optional Keys			
Code	D Series Key No.	Code	D Series Key No.
Blank	D018 (std. key)	15	T112
03	D020	16	T115
04	D025	17	T324
05	D335	18	T382
06	D429	19	T404
07	D461	20	T171
08	D111	21	T484
09	D587	22	T547
10	D682	23	T569
11	D713	24	T692
12	D900	25	T752
13	D992	26	T178
14	D118		

e	
Cam Options	
Code	Description
KB6	Cam for maintained operators
KL8	Cam for spring return operators

f			
Contact Blocks			
Code	Contact Config.	2-position ⁽¹⁾	
Standard			
Blank	No contacts	—	—
DXXX	1 N.O.	0	X
EXXX	1 N.C.	X	0
MXXX	2 N.O.	0	X
NXXX	2 N.C.	X	0
AXXX	1 N.O. - 1 N.C.	0	X
		X	0
AAXX	2 N.O. - 2 N.C.	0	X
		X	0
		0	X
		0	X
		X	0

f, continued			
Contact Blocks			
Code	Contact Config.	2-position	
PentUFF™ (Low Voltage)			
HXXX	1 N.O.	0	X
UXXX	1 N.C.	X	0
FXXX	1 N.O. - 1 N.C.	0	X
		X	0
FFXX	2 N.O. - 2 N.C.	0	X
		X	0
		0	X
		0	X
		X	0

(1) X = Closed/0 = Open

4-position, Non-illuminated

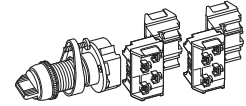

800	H	-	NP	2	KF4	AAXX	(Knob/Wing Lever)
	a		b	c	d	e	f
800	H	-	NP	31	KF4	AXXX	(Cylinder Lock)
	a		b	c ₁	d ₁	e	f

a	
Barrel Type	
Code	Description
H	Standard barrel
HL	Long barrel

b	
Number of Positions	
Code	Description
NP	4-position

c	
Knob Insert Colors ⁽¹⁾	
Code	Description
Blank	White
X	Packet of colored inserts ⁽²⁾
Metal Wing Lever Colors	
A	Red
Blank	Gray

- (1) Each standard and knob lever operator is factory-assembled with a white insert. Other colors are available, factory-assembled, if ordered in quantities of 10 or more.
- (2) One insert of each color (blue, green, orange, red, and yellow).

c ₁	
Key Removal Position and Operator Function	
Code	Description
Maintained	
31	Key removal position 1
32	Key removal position 2
33	Key removal position 3
34	Key removal position 4
61	Key removal all positions
Spring Return from Position 1 to 2	
132	Key removal position 2
133	Key removal position 3
134	Key removal position 4
154	Key removal positions 2, 3, and 4
Spring Return from Position 4 to 3	
231	Key removal position 1
232	Key removal position 2
233	Key removal position 3
251	Key removal positions 1, 2, and 3

d	
Operator Type and Function	
Code	Description
Standard Knob	
2	Maintained
3	Spring return position 1 to 2
9	Spring return from position 4 to 3
Knob Lever	
17	Maintained
29	Spring return from position 1 to 2
30	Spring return from position 4 to 3
Metal Wing Lever	
11	Maintained
13	Spring return from position 1 to 2
14	Spring return from position 4 to 3

d ₁	
Optional D-Series Keys ⁽¹⁾	
Code	Description
Blank	D018 (standard key)

- (1) Devices are supplied with two keys. Replacement part number for standard D018 key is X-181170.

e	
Cam Options	
Code	Description
KF4	F cam (standard)
KG4	G cam
KK4	K cam
KM4	M cam
KP4	P cam
KH4	Overlapping cam

f	
Contact Blocks	
Code	Description
Blank	No contacts
AAXX	Two contact targets for a given cam as shown in the W (white side) column of Table 10 and two contact targets for the same cam as shown in the B (black side) column of Table 10. (One Cat. No. 800T-XA contact block per side. Two contact blocks total)
AAAA	Four contact targets for a given cam as shown in the W (white side) column of Table 10 and four contact targets for the same cam as shown in the B (black side) column of Table 10. (Two Cat. No. 800T-XA contact blocks per side. Four contact blocks total.)

Table 10 - Selector Switch Cam Targets

Contact Block Suffix Code	Contact Block Side	Circuits	Cam Codes ⁽¹⁾																								
			KF4				KG4				KK4 ⁽²⁾				KM4 ⁽²⁾				KP4				KN4 ⁽³⁾				
			↻	↻	↻	↻	↻	↻	↻	↻	↻	↻	↻	↻	↻	↻	↻	↻	↻	↻	↻	↻	↻	↻	↻	↻	
AAAA FFFF	White	A	X	0	0	0	X	X	0	0	0	0	X	X	X	0	0	0	0	0	0	X	0	X	0	0	
		B	0	X	0	0	0	0	X	0	X	X	0	0	0	X	X	0	0	X	0	0	0	0	0	0	X
	Black	A	0	0	0	X	X	0	0	0	X	0	0	X	0	0	0	X	0	0	X	0	0	0	0	X	0
		B	0	0	X	0	0	0	0	X	0	X	X	0	0	0	X	X	0	0	X	0	0	0	0	0	X
	White	A	X	0	0	0	X	X	0	0	0	0	X	X	X	0	0	0	0	0	0	X	0	X	0	0	0
		B	0	X	0	0	0	0	X	0	X	X	0	0	0	X	X	0	0	X	0	0	0	0	0	0	X
Black	A	0	0	0	X	X	0	0	0	X	0	0	X	0	0	X	0	0	X	X	0	0	0	0	X	0	
	B	0	0	X	0	0	0	0	X	0	X	X	0	0	X	0	0	X	0	0	0	0	0	X	0	0	

- (1) X = Closed, 0 = Open For additional targets and overlapping cams, see Publication 800T-2.8.
- (2) Not available with wing lever operator.
- (3) Overlapping cam.

Pilot Light Devices



Transformer Type Pilot Light
Cat. No. 800H-PP16M



Push-to-test Pilot Light
Cat. No. 800H-PPT16M



Pigtail Pilot Light
Cat. No. 800H-LP24M

800 H - PP T 16 M
 a b c d e f

a	
Barrel Type	
Code	Description
H	Standard barrel
HL	Long barrel

b	
Power Module Type	
Code	Description
PP	Transformer (or dual-input)
QP	Full voltage/Universal
LP	Pigtail — full voltage ⁽¹⁾
LPK	Pigtail — full voltage ⁽¹⁾ (for dual push buttons)

c	
Lamp Test Options	
Code	Description
Blank	No test option
T	Push-to-test
D	Dual-input — diode ⁽²⁾
DT	Dual-input — transformer relay ⁽²⁾

d	
Illumination Option	
Code	Description
Blank	Incandescent
H	LED ⁽³⁾

e	
Voltage	
Code	Description
Transformer	
16	120V AC, 50/60 Hz
26	240V AC, 50/60 Hz
46	480V AC, 50/60 Hz
56	600V AC, 50/60 Hz
Full Voltage — Incandescent	
24	24V AC/DC
10	120V AC/DC
20	240V AC/DC

e, continued	
Voltage	
Code	Description
Universal — LED	
2	12...130V AC/DC
Dual-input	
16	120V AC
24	24V AC/DC ⁽⁵⁾
Pigtail	
24	24V AC/DC
10	120V AC/DC
20	240V AC/DC

f	
Lens Color	
Code	Description
Blank	No lens with no contacts
M	Multi-color ⁽⁴⁾

- (1) Lamp test option is not available with pigtail.
- (2) Only available with power module type code PP (Table b).
- (3) LED illumination option is not available with diode-type dual-input lamp test options.
- (4) Multi-color insert packet includes amber, blue, green, red, and white.
- (5) Dual-input diode only.

Typical Pilot Light Wiring Diagrams

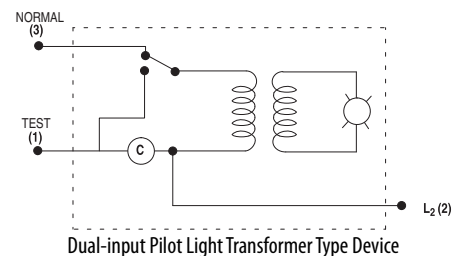
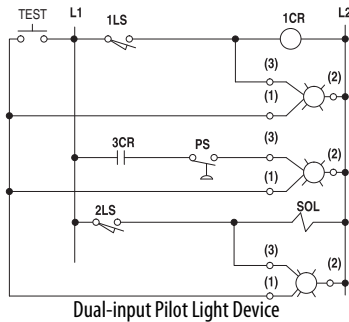
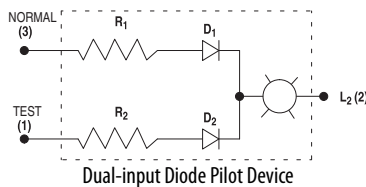
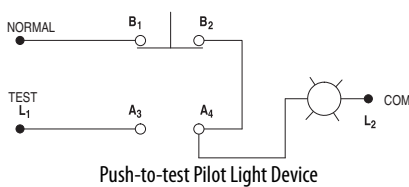

IMPORTANT See applicable codes and laws.

Potentiometer Units

- Single-turn operation with 312° rotation.
- Rated for 300V AC/DC, 2 W max.



Potentiometer Units
Cat. No. 800H-UP24

800 H – UP 13
 a b c

a	
Barrel Type	
Code	Description
H	Standard barrel
HL	Long barrel

b	
Resistance ⁽¹⁾	
Code	Description
13	1 Ω
19	2.5 Ω
24	5 Ω
29	10 Ω

(1) For operator only (no resistive element), order catalog number 800H-NP37 which is for use with Type J potentiometers having a shaft length of 7/8 in. (22.2 mm) and a shaft diameter of 1/4 in. (6.3 mm).

Ordering Information for Bulletin 800H Stations

Bulletin 800H Type 7 and 9 stations are available as factory assembled or as components for field assembly.

Factory-assembled Stations

Bulletin 800H Type 7 and 9 control stations are designed to meet the requirements of the National Electrical Code. These stations are listed by Underwriters Laboratories, Inc. for Class I, Divisions 1 & 2, Groups C & D Hazardous Gases or Vapors, Class II, Divisions 1 & 2, Groups E, F & G Hazardous Dust and Class III Hazardous Fiber Locations. In addition, the single gang shallow base, Cat. No. 800H-IHZX7, meets Class I, Group B requirements as defined in the National Electrical Code.

Factory-assembled stations can be ordered in following ways:

- Standard, factory-assembled stations listed on [page 6](#).
- Custom, factory-assembled stations can be ordered by following the instructions that are listed on this page.

Components for Field Assembled Stations

Eight-gang maximum. These 2- and 3-gang modules can be assembled into the multi-gang stations by installing a coupler kit between the enclosures. These separate bases, covers, or bases with covers are Underwriters Laboratories, Inc. listed when properly assembled. These

enclosures meet the requirements of Class I, Division 1 & 2, Groups C & D, Class II, Divisions 1 & 2, Groups E, F & G, and Class III hazardous locations as defined in the National Electrical Code. Bulletin 800H Type 7 and 9 components are designed for these modular enclosures and are UL Listed for this purpose.

IMPORTANT Components may be assembled as multi-gang units up to an eight-gang maximum. ⁽¹⁾

(1) Flange width is designed to comply with Underwriters Laboratories standards to enclosures with an internal free volume of up to 300 cubic inches (a maximum 8-gang assembly).

Instructions for Ordering Custom-built Stations

To select components for field assembly, follow these instructions:

1. Select operators required from [page 6](#). (If lever type, select covers from [page 19](#) and go to [step 3](#)).
2. Select covers based on mounting requirements on [page 19](#).
3. Select an assembled base from [page 20](#) in accordance with the number of covers selected in [step 2](#).
4. Select legend plates from [page 28](#) (and accessories, if required, from [page 22](#)).
5. If a particular sequence of operators or mounting orientation (vertical versus horizontal) is required, include a rough sketch.

Station Design Guidelines

IMPORTANT See applicable codes and standards.

1. Push-to-test pilot lights, illuminated push buttons, push-to-pull units, 4-position selector switches, and all operators with two contact blocks that are fastened along side one another or with a power module and contact block along side one another must be installed in a single-hole cover. Illuminated operators that use the Universal LED module must be installed in a single-hole cover as well.
2. Dual push button units can only be installed in a single-hole cover or the specially designed two-hole cover (catalog number 800H-NP33), which can accommodate the dual push button and the special pigtail pilot light (catalog number 800H-LPK10R).
3. When two components are installed in one cover, contact blocks are restricted to one side of the operator. Contact blocks of each operator must face each other.
4. One level of contact blocks is the maximum in a shallow base or deep base when used with a sealing well. Contact blocks, except sealed switch type, can be mounted two deep in other bases.
5. If sealed switch contact blocks or a sealing well are used, a deep enclosure is required.
6. Push buttons/pilot lights:
 - a. START push buttons must be green or black flush, installed to the left or above STOP push buttons.
 - b. EMERGENCY STOP push buttons must be a red mushroom.
 - c. STOP push buttons must be red extended, installed to the right or below START push button.
 - d. STOP push buttons must be installed in the last position (bottom or right) of each unit when required.
 - e. Pilot lights must be installed in the first position (top or left side) of each unit when required.

Design Guideline #1

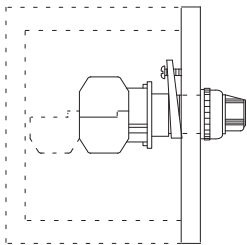

Push-to-test pilot lights, illuminated push buttons, push-pull units, 4-position selector switches, all operators with two contact blocks that are fastened along side one another or with a power module and contact block along side one another must be installed in a single-hole cover. Illuminated operators that use the Universal LED module must be installed in a single-hole cover as well.

Design Guideline #2

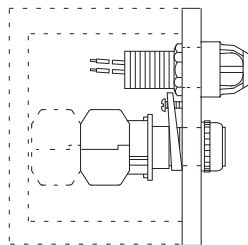

Dual push button units can only be installed in a single-hole cover or the specially designed two-hole cover (catalog number 800H-NP33), which can accommodate the dual push button and the special pigtail pilot light (catalog number 800H-LPK10R).

Design Guideline #3

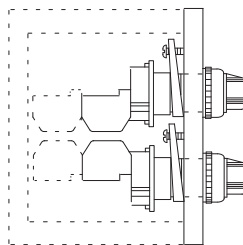

When two components are installed in one cover, contact blocks are restricted to one side of the operator. Contact blocks of each operator must face each other.

Design Guideline #4

One level of contact blocks is the maximum in a shallow base or deep base when used with a sealing well. Contact blocks, except sealed switch type, can be mounted two deep in other bases.

Covers and Bases

The following covers and bases are available for your Bulletin 800H station.

Covers, Lever Type Actuator

IMPORTANT Lever type covers are furnished without contact blocks. Legend plate for half lever is STOP; full lever momentary and maintained is a START-STOP. To order without legend plate, add suffix X to the cat. no.

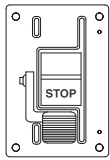
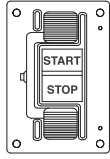
	Description	Cat. No.
	Half lever	800H-NP14
	Double lever, momentary	800H-NP15
	Double lever, maintained	800H-NP16
	Double lever, momentary/maintained ⁽¹⁾	800H-NP34

(1) A normally open circuit configuration is recommended for use behind this momentary lever and a late break normally closed circuit configuration is required for use behind the maintained lever to achieve proper functioning of the device.

Covers, Component Type Button

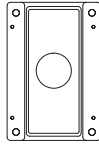
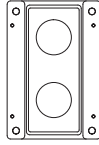
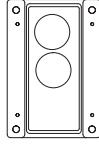
	Description	Cat. No.
	Blank	800H-NP32
	One-hole ⁽¹⁾	800H-NP30
	Two-hole ⁽²⁾	800H-NP31
	Two-hole special ⁽³⁾	800H-NP33

(1) One-hole covers use a jumbo legend plate only.

(2) Two-hole covers use a standard legend plate only.

(3) This special two-hole cover can accommodate the pigtail pilot light (Bulletin 800H-LPK10 series), the dual push button or any non-illuminated unit. Legend plates (Cat. No. 800H-Y140J green and red split-field) and (Cat. No. 800H-Y141J gray full field), are the only legend plates suitable for use with this cover.

Assembled Bases (for Field Assembly and Custom Stations)

- Enclosure Covers — See enclosure cover tables for a complete listing of covers for these bases.
- Special Conduit Entries — For conduit entries not listed, consult your local Rockwell Automation sales office or Allen-Bradley distributor.

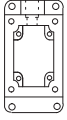
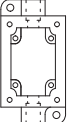
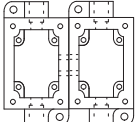
	Description	Conduit Entry	Cat. No.
	1-gang shallow ⁽¹⁾	3/4 in. dead end	800H-1HZX7
	1-gang deep ⁽²⁾	3/4 in. dead end	800H-1HVX7
		3/4 in. feed through	800H-1HVX7M1
		1 in. dead end	800H-1HVX7M2
		1 in. feed through	800H-1HVX7M3
	2-gang horizontal ⁽²⁾	1 in. dead end	800H-2HHX7

(1) Shallow base cannot accommodate sealing well, sealed switched contact blocks, or stacked contact blocks. Shallow base rated for Group B.

(2) Deep base can accommodate sealing well, sealed switch contact blocks, or up to 2 deep standard contact blocks.

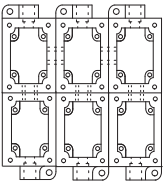
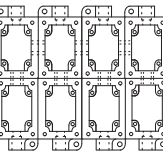

	Description	Conduit Entry	Cat. No.
	6-gang ⁽¹⁾	1 in. feed through	800H-6HVX7
	8-gang ⁽¹⁾		800H-8HVX7

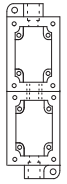
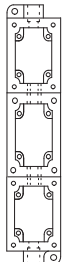
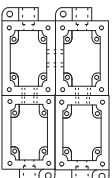
(1) Deep base can accommodate sealing well, sealed switch contact blocks, or up to 2 deep standard contact blocks.

	Description	Conduit Entry	Cat. No.
	2-gang vertical ⁽¹⁾	1 in. feed through	800H-2HYX7
	3-gang vertical ⁽¹⁾		800H-3HYX7
	4-gang ⁽¹⁾		800H-4HVX7

(1) Deep base can accommodate sealing well, sealed switch contact blocks, or up to 2 deep standard contact blocks.

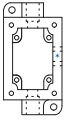
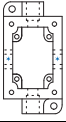
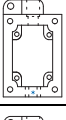
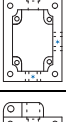
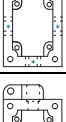
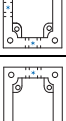
Bases for Multi-gang Stations

	Conduit Size	Cat. No.
	3/4 in. feed through	800H-NP40C
	1 in. feed through	800H-NP40D
	3/4 in. feed through	800H-NP41C
	1 in. feed through	800H-NP41D
	3/4 in. dead end	800H-NP42A
	1 in. dead end	800H-NP42B
	3/4 in. dead end	800H-NP43A
	1 in. dead end	800H-NP43B
	3/4 in. dead end	800H-NP44A
	1 in. dead end	800H-NP44B
	3/4 in. dead end	800H-NP46A
	1 in. dead end	800H-NP46B
	None	800H-NP45

Example

7-gang base with 1-in. through-feed conduit consists of the following:

Cat No.	Quantity
800H-NP42B	3
800H-NP43B	1
800H-NP44B	1
800H-NP45	1
800H-NP46B	1
800H-NP7	6

Plus up to four 1-in. plugs (catalog number 800H-NP11) to close unused conduit openings.



WARNING: Do not assemble more than eight enclosure gangs together, to avoid exceeding the internal volume for which the flame path of these enclosures is designed.

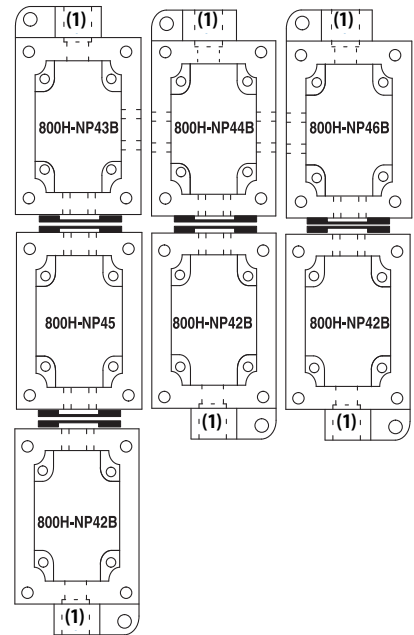



(1) 1-in. conduit through-feed (all gangs).

Modifications and Accessories

Contact Blocks

Packaged in kit form for field installation. All necessary mounting hardware is provided with each contact block kit. Contact ratings are listed on [page 5](#).



IMPORTANT It is not recommended to mount more than four contact blocks on any one unit (maximum two blocks deep). Sealed switch contact blocks are limited to two blocks per unit maximum.

Contact Type	 Shallow Block	 Mini Block	 PentUFF (Low Voltage) Block
	Cat. No. ⁽¹⁾ ⁽²⁾ ⁽³⁾	Cat. No. ⁽¹⁾ ⁽³⁾	Cat. No. ⁽¹⁾ ⁽²⁾ ⁽³⁾
1 N.O.	800T-XD1	800T-XD5	800T-XD1V
1 N.C.	800T-XD2	800T-XD6	800T-XD2V
1 N.O.E.M.	800T-XD3	—	800T-XD3V
1 N.C.L.B.	800T-XD4	—	800T-XD4V
1 N.O. - N.C.	800T-XA	—	800T-XAV
2 N.O.	800T-XA2	—	—
2 N.C.	800T-XA4	—	—
1 N.C.L.B. - 1 N.O.	800T-XA1	—	—
1 N.C.L.B. - 1 N.C.	800T-XA7	—	—

(1) To determine if a conduit seal-off is necessary, see [Table 18](#) on [page 26](#) for sealing well information.

(2) Specify Bulletin 800TC for finger-safe contact blocks. Example: Cat. No. 800TC-XA.

(3) Contact blocks with normally closed contacts meet direct drive positive opening standard requirements.

Contact Type	 Logic Reed Block	 Sealed Switch Block	 Stackable Sealed Switch Block
	Cat. No. ⁽¹⁾	Cat. No. ⁽¹⁾	Cat. No. ⁽¹⁾
1 N.O.	800T-XD1R	800T-XD1P	800T-XD1Y
1 N.C.	800T-XD2R	800T-XD2P	800T-XD2Y
1 N.O. - 1 N.C.	800T-XAR	800T-XAP	800T-XAY
2 N.O.	800T-XA2R	—	800T-XA2Y
2 N.C.	800T-XA4R	—	800T-XA4Y

(1) To determine if a conduit seal-off is necessary, see [Table 18](#) on [page 26](#) for sealing well information.

Replacement Color Caps

Table 11 - Illuminated













	 Pilot Light	 Push-to-test Pilot Light	 Illuminated Push Button	 Illuminated Push-Pull
Color	Cat. No.	Cat. No.	Cat. No.	Cat. No.
Multi-color kit	800H-N104M	800H-N105M	800H-N106M	800H-NP50M

Table 12 - Non-illuminated

	 Momentary Mushroom — Standard (Plastic)	 Momentary Mushroom — Jumbo (Metal)	 Push-pull Standard (Metal)	 Push-pull Jumbo (Metal)
Color	Cat. No.	Cat. No. ⁽¹⁾	Cat. No.	Cat. No.
Red	800T-N246R	800T-N248R	800H-NP51A	800H-NP52A
Green	800T-N246G	800T-N248G	800H-NP51B	800H-NP52B
Blue	800T-N246BL	800T-N248BL	800H-NP51C	800H-NP52C
Yellow	800T-N246Y	800T-N248Y	800H-NP51E	800H-NP52E
Black	800T-N246B	800T-N248B	800H-NP51H	800H-NP52H
Gray	800T-N246GR	800T-N248GR	800H-NP51G	—
Natural	—	800T-N248	—	—

(1) To order plastic jumbo mushroom caps, replace 248 with 247. Plastic not available in natural color. Example: Cat. No. 800T-N248R becomes Cat. No. 800T-N247R.

Replacement Knobs and Dual Push Button Assembly

	 Standard Knob	 Knob Lever	 Wing Lever	 Dual Push Button
Color	Cat. No.	Cat. No.	Cat. No. ⁽²⁾	Cat. No.
White	800H-N130F	800H-N131F	—	—
Kit (Complete) ⁽¹⁾	800H-N130	800H-N131	—	—
Gray	—	—	800H-N138	—
Red	—	—	800H-N138A	—
Green Red	—	—	—	800H-NP39

(1) Kit includes knob and packet of inserts (Cat. No. 800T-N123). See [Table 18](#) on [page 26](#) for color insert kits.

(2) Standard finish is gray.

Boots—Non-illuminated Momentary Contact Push Buttons Units

IMPORTANT For Bulletin 800H/HL Type 7 and 9 operators, order one adapter and one boot per operator.

Boots supplied with control stations and components are made of a chlorosulfonated polyethylene material with stainless steel insert ring. To order boots with silicone, urethane, or ethylene propylene material, see the following table. Material application information is shown.





IMPORTANT Can be added to flush or extended head push button units to help protect against foreign materials reaching the opening between the push button and the locking ring.

Table 13 - Boots

Insert Material	Boot Color	Material			
		Chlorosulfonated Polyethylene ⁽²⁾	Silicone ⁽²⁾	Urethane ⁽²⁾	Ethylene Propylene ⁽²⁾
		Cat. No.	Cat. No.	Cat. No.	Cat. No.
Stainless steel ⁽¹⁾	Red	800H-N5A	800H-N101R	800H-N100R	800H-N103R
	Green	800H-N5B	800H-N101G	800H-N100G	800H-N103G
	Black	800H-N5H	800H-N101B	800H-N100B	800H-N103B
	Yellow	800H-N5E	800H-N101Y	800H-N100Y	—
	Blue	800H-N5C	800H-N101BL	800H-N100BL	—

(1) Series B boots incorporate a stainless steel insert as standard.
 (2) Dots printed on the inside of the boot identify the boot material.

Table 14 - Booted Knobs





	Switch Type	Material			
		Chlorosulfonated Polyethylene ⁽²⁾	Silicone ⁽²⁾	Urethane ⁽²⁾	Ethylene Propylene ⁽²⁾
		Cat. No.	Cat. No.	Cat. No.	Cat. No.
	Standard knob selector switch ⁽¹⁾	800H-NP5	800H-NP101	800H-NP100	800H-NP103
	Knob lever selector switch ⁽¹⁾	800H-NPE5	800H-NPE101	800H-NPE100	800H-NPE103

(1) Includes color insert kit.
 (2) Dots printed on the inside of the boot identify the boot material.

Table 15 - Adapters



Push Button Type	Cat. No.
Flush head	800H-NPAF
Extended head	800H-NPAE

Push Button Guards and Mushroom Push Button Guards

	Description	Cat. No.
	Push buttons, pilot lights, and push-to-test	800H-NP19
	Extra long guard (1 in.) for push button	800H-NP13
	Mushroom	800H-NP9
	Jumbo mushroom	800H-NP12

Protective Rings for Push-pull Operators

Protective ring for Bulletin 800H 2-position non-illuminated push-pull operators. Often used to avoid unintentional tripping of E-stop operators. Available for standard (40 mm) or jumbo (60 mm) push buttons.

	Description	Cat. No.
	For standard-size button	800H-NP40
	For jumbo size button	800H-NP40J

General Accessories

Table 16 - Plugs







	Description		Cat. No.
	Coupler Used for both horizontal and vertical assembly.		800H-NP7
	Description	Type	Cat. No.
	Closing Plug Whenever an enclosure with more than the required number of openings is used, this plug can be used to close the unused openings. Includes synthetic O-ring washer.	For cover hole	800H-NP1
		For base coupler Hole	800H-NP3
	Description	Size	Cat. No.
	Conduit Entry Plug This plug can be used to plug unused conduit openings in Type 7 and 9 bases.	3/4 in.	800H-NP10
		1 in.	800H-NP11





Table 17 - Locking Attachments

	Description	Cat. No. ⁽²⁾
	Push Button Padlocking Attachments This device permits locking in the depressed position on extended head push button units only.	800H-NP2
	Dual Push Button Extended Head Padlocking Attachments This device permits locking for dual push button — extended head units only.	800H-NP17
	Padlocking Cover ⁽¹⁾ Padlocking cover is used for Type 7 and 9 selector switches, non-illuminated push buttons (except mushrooms), and non-illuminated 2-position push-pull units, but not for potentiometer units.	800H-NP4

(1) Push-pull units only lock in the depressed position. Padlocking cover includes blank legend plate for customer marking. A premarked legend plate entitled OPEN COVER TO OPERATE (front view) and PULL-TO-START-PUSH-TO-STOP (rear view) is available. To order legend plate only, specify Cat. No. 800H-W174L.



(2) Padlock not included.

Table 18 - Miscellaneous

	Description	Style	No. of Wires	Cat. No.
 Cat. No. 800H-NPRD91	Sealing Well with Integral Type 3 Flange Seal These sealing wells can only be used with bases having 1 in. conduit entries. They reduce costs necessary with other conduit seal fittings for most installations (subject to applicable codes and laws) while maintaining Type 7 and 9 integrity. When using a sealing well with integral flange seal for Type 3 outdoor applications, an approved drain fitting must be provided. (Refer to National Electrical Code.)	With Integral Flange Seal, Type 3, 7, and 9	2	800H-NPRD90
			4	800H-NPRD91
			6	800H-NPRD92
			8	800H-NPRD93
	Description	Style		Cat. No.
 Cat. No. 800H-NP20	Type 3 Flange Seal This seal provides a Type 3 rating while maintaining Type 7 and 9 integrity. An approved drain (see listing) is required for condensation when using this option (refer to National Electrical Code). For a Type 4 rating, use sealing nuts and flange seal to seal the push button operators. Sealing kit includes flange seal and sealing nut. They are used with the Allen-Bradley enclosures listed on Complete Assembled Stations (Supplied with 3/4 in. Dead End Conduit Entry — Cat. No. 800H-1HZX7) for outdoor applications.	Flange Seal		800H-NP20
		Drain for 3/4 in. Conduit Opening		800H-NP21
		Drain for 1 in. Conduit Opening		800H-NP22
 Cat. No. 800H-NP21		Type 4 Sealing Nut		800H-N479
		Type 4 Sealing Kit		800H-N479F
	Description	Color		Cat. No.
 Cat. No. 800H-NP20	Color Insert Kit These color insert kits are used with illuminated push buttons, pilot lights, push-pull, and push-to-test push buttons (order quantity of 1 to receive kit of 5 inserts).	Red		800H-NP23R
		Green		800H-NP23G
		Amber		800H-NP23A
		Blue		800H-NP23B
		White		800H-NP23W

Replacement Lamps

Table 19 - Pilot Lights, Illuminated Push Buttons, Illuminated Push-pull, Illuminated Push-pull/Twist to Release, and Illuminated Selector Switches

Lamp	Type	Current, Typical	Lamp Voltage	ANSI No.	Catalog Voltage Code	Cat. No.
Incandescent 	Full Voltage Transformer	150 mA/250 mA	6.3V AC	755/1866	6, 16, 26, 36, 46, 56, 76	800T-N65 ⁽³⁾
	Full Voltage	80 mA	14V AC/DC	756	12	800T-N141 ⁽³⁾
		70 mA	24V AC/DC	757	24	800T-N157 ⁽³⁾
		50 mA	48V AC/DC	1835	48	800T-N365 ⁽³⁾
	Full Voltage Resistor	22 mA	120V AC/DC	949	10, 11	800T-N169 ⁽³⁾
	Flashing	150 mA	6V AC/DC	267	6	800T-N212 ⁽³⁾
	Dual-input Diode	57 mA	24V AC/DC	24 MB	24	800T-N180 ⁽³⁾
21 mA		120V AC	90 MB	16	800T-N261 ⁽³⁾	
Neon 	—	2 mA	120V AC/DC	B2A	10, 20	609-N9
Lamp	Type	Current, Typical	Lamp Voltage	Leakage Current	Code	Cat. No. ⁽⁴⁾
LED 	Universal	13 mA @ 24V DC 8.5 mA @ 120V AC ⁽¹⁾	3V ⁽²⁾	3 mA	2	800T-N376x
	Transformer	60	6V	14 mA	16, 26, 46, 56	800T-N377x

- (1) Typical current consumption values indicated are relative to the input of the power module.
- (2) Lamp is intended for use with power module Cat. No. 800TC-N374 which has an input voltage rating of 12 ... 130V AC/DC.
- (3) Item is sold in multiples of five. Order quantity of five to receive package of five pieces.
- (4) To complete the cat. no. replace the x with the first letter of the desired color: Green, Red, or White.

Table 20 - Legacy LED Lamps ⁽¹⁾

Lamp	Type	Current, Typical ⁽³⁾	Lamp Voltage	Leakage Current	Catalog Voltage Code	Cat. No. ⁽⁴⁾
LED ⁽²⁾ 	Full Voltage	13 mA/22 mA	12V AC/DC	3 mA	12	800T-N362x
		20 mA/21 mA	24V AC/DC	3 mA	24	800T-N319x
		12 mA/17 mA	32V AC/DC	3 mA	32	800T-N363x
		9 mA/14 mA	48V AC/DC	3 mA	48	800T-N364x
		3.3 mA/6 mA	120V AC	—	10	800T-N320x
		4.5 mA/6.2 mA	130V AC/DC	3 mA	13	800T-N321x
	Full voltage	50 mA	6V AC	14 mA	6, 16, 26, 36, 46, 56, 76	800T-N318x
	Flashing	18 mA	24V AC/DC	—	—	800T-N319Fx ⁽⁵⁾

- (1) In full voltage applications, these lamps are intended to be used with power module Cat. No. 800T-N330.
- (2) All LEDs except 120V have an internal shunt resistor for use with solid-state outputs. LEDs do not illuminate below listed leakage current.
- (3) Typical current draw varies with LED color. The first mA value is for a green or blue LED and the second mA value is for a red or amber LED.
- (4) To complete the cat. no. replace the x with the first letter of the desired color: Amber, Green, Red, Blue, or White. White LEDs only available in 6V, 24V, 120V, and 130V.
- (5) Flashing rate is 2 Hz.

Legend Plates

Table 21 - Blank Legend Plates

	 Lever Style	 Standard Size	 Jumbo Size	 Special Jumbo Size
	Use 1 lever style legend with each lever type cover (Cat. Nos. 800H-NP14, -NP15, -NP16 or -NP34)	Use 2 standard size legends with each standard 2 hole cover (Cat. No. 800H-NP31)	Use 1 jumbo size legend with each standard 1 hole cover (Cat. No. 800H-NP30)	Use 1 special jumbo legend with each special 2 hole cover (Cat. No. 800H-NP33) Ex: Dual Push Button/Pigtail Pilot Light
Legend Plate Color	Cat. No.	Cat. No.	Cat. No.	Cat. No.
Gray	—	800H-Y59	800H-Y59J	800H-Y141J
Red	—	800H-Y121	800H-Y121J	—
Green	—	800H-Y136	800H-Y136J	—
Yellow	—	800H-Y700	800H-Y700J	—
Top Gray — Bottom Gray	800H-Y222	—	—	—
Top Gray — Bottom Red	800H-Y223	—	—	—
Left Green — Right Red	—	—	—	800H-Y140J
Gray with Potentiometer Graduations	—	800H-Y109	800H-Y109J	—

Table 22 - Custom Legend Plates

	Lever Style	Standard Size	Jumbo Size	Special Jumbo Size
	Use 1 lever style legend with each lever type cover (Cat. Nos. 800H-NP14, -NP15, -NP16 or -NP34)	Use 2 standard size legends with each standard 2 hole cover (Cat. No. 800H-NP31)	Use 1 jumbo size legend with each standard 1 hole cover (Cat. No. 800H-NP30)	Use 1 special jumbo legend with each special 2 hole cover (Cat. No. 800H-NP33) Ex: Dual Push Button/Pigtail Pilot Light
Legend Plate Color	Cat. No.	Cat. No.	Cat. No.	Cat. No.
Gray	—	800H-Y59E ⁽¹⁾	800H-Y59JE ⁽¹⁾	800H-Y141JE ⁽¹⁾
Red	—	800H-Y121E ⁽¹⁾	800H-Y121JE ⁽¹⁾	—
Green	—	800H-Y136E ⁽¹⁾	800H-Y136JE ⁽¹⁾	—
Yellow	—	800H-Y700E	800H-Y700JE	—
Top Gray — Bottom Gray	800H-Y222E ⁽¹⁾	—	—	—
Top Gray — Bottom Red	800H-Y223E ⁽¹⁾	—	—	—
Left Green — Right Red	—	—	—	800H-Y140JE ⁽¹⁾
Gray with Potentiometer Graduations	—	800H-Y109E ⁽¹⁾	800H-Y109JE ⁽¹⁾	—

(1) Horizontally mounted engraved legend plates (with standard or custom marking) are available. Add the letter H after the Y in the cat. no. Example: Cat. No. 800H-Y222E becomes 800H-YH222E.

Table 23 - Lever Style Legend Plates with Standard Markings

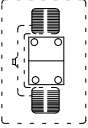
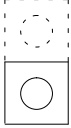
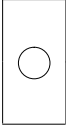
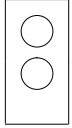
Legend Marking	Cat. No.	Legend Marking	Cat. No.
Upper/Lower		Upper/Lower	
HAND/AUTO	800H-Y228	OPEN/CLOSE	800H-Y205
JOG/RUN	800H-Y227	RUN/STOP (Red)	800H-Y226
JOG/STOP (Red)	800H-Y206	START/STOP (Red)	800H-Y200
ON/OFF	800H-Y225		

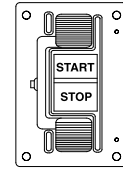
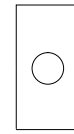

Table 24 - Legend Plates with Standard Markings

Legend Marking	Standard Size	Jumbo Size	Legend Marking	Standard Size	Jumbo Size
	Cat. No.	Cat. No.		Cat. No.	Cat. No.
AUTO-OFF-HAND	800H-Y1	800H-Y1J	ON	800H-Y30	800H-Y30J
AUTO-MAN-HAND	800H-Y125	800H-Y125J	OPEN	800H-Y31	800H-Y31J
CLOSE	800H-Y2	800H-Y2J	OPEN-CLOSE	800H-Y32	800H-Y32J
CYCLE START	800H-Y62	800H-Y62J	OPEN-OFF-CLOSE	800H-Y33	800H-Y33J
DOWN	800H-Y3	800H-Y3J	OUT	800H-Y34	—
EMERG. STOP (Red)	800H-Y4	800H-Y4J	PUSH TO STOP-PULL TO START	800H-Y118	800H-Y118J
FAST	800H-Y5	800H-Y5J	POWER ON	800H-Y139	800H-Y139J
FEED START	800H-Y66	800H-Y66J	RAISE	800H-Y35	800H-Y35J
FEED STOP	800H-Y67	800H-Y67J	RAISE-LOWER	800H-Y36	800H-Y36J
FOR.-REV.	800H-Y6	800H-Y6J	RAISE-OFF-LOWER	800H-Y37	800H-Y37J
FOR.-OFF-REV.	800H-Y7	800H-Y7J	RESET	800H-Y38	800H-Y38J
FORWARD	800H-Y8	800H-Y8J	REVERSE	800H-Y39	800H-Y39J
FOURTH SPEED	800H-Y124	800H-Y124J	RUN	800H-Y40	800H-Y40J
FULL SPEED	800H-Y9	800H-Y9J	RUN-INCH	800H-Y134	800H-Y134J
HAND-AUTO	800H-Y10	800H-Y10J	RUN-JOG	800H-Y41	800H-Y41J
HAND-OFF-AUTO	800H-Y11	800H-Y11J	SAFE-RUN	800H-Y42	800H-Y42J
HIGH	800H-Y12	800H-Y12J	SECOND SPEED	800H-Y43	800H-Y43J
HIGH-LOW	800H-Y13	800H-Y13J	SLOW	800H-Y44	800H-Y44J
HIGH-OFF-LOW	800H-Y14	800H-Y14J	SLOW-FAST	800H-Y45	800H-Y45J
IN	800H-Y15	800H-Y15J	SLOW-OFF-FAST	800H-Y46	800H-Y46J
INCH	800H-Y16	800H-Y16J	SPEED ⁽¹⁾	800H-Y108	800H-Y108J
JOG	800H-Y17	800H-Y17J	START (Green)	800H-Y47	800H-Y47J
JOG FORWARD	800H-Y18	800H-Y18J	START-JOG	800H-Y48	800H-Y48J
JOG REVERSE	800H-Y19	800H-Y19J	START-STOP	800H-Y49	800H-Y49J
JOG-RUN	800H-Y20	800H-Y20J	STOP (Red)	800H-Y50	800H-Y50J
JOG-SAFE-RUN	800H-Y22	800H-Y22J	STOP-START	800H-Y51	800H-Y51J
JOG-STOP-RUN	800H-Y21	800H-Y21J	SUMMER-OFF-WINTER	800H-Y53	800H-Y53J
LEFT-RIGHT	800H-Y23	800H-Y23J	SUMMER-WINTER	800H-Y52	800H-Y52J
LOW	800H-Y24	800H-Y24J	TEST	800H-Y54	800H-Y54J
LOW SPEED	800H-Y25	—	THIRD SPEED	800H-Y55	—
LOWER	800H-Y26	800H-Y26J	UP	800H-Y56	800H-Y56J
OFF	800H-Y27	800H-Y27J	UP-DOWN	800H-Y57	800H-Y57J
OFF-COOLANT-ON	800H-Y28	800H-Y28J	UP-OFF-DOWN	800H-Y58	800H-Y58J
OFF-ON	800H-Y29	800H-Y29J			



Standard



Jumbo

(1) Graduated potentiometer type.

Approximate Dimensions and Shipping Weights

Dimensions in millimeters (inches). Dimensions are not intended to be used for manufacturing purposes.

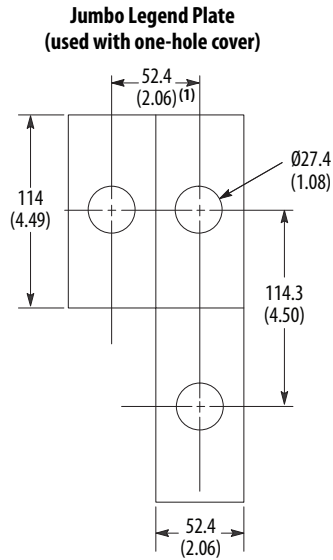
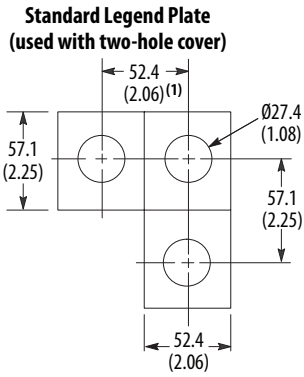

IMPORTANT Mounting hole requirements for components — 3/4 in. - 14 NPSM. ⁽²⁾

- (1) Sketch illustrates the minimum distance between center lines when mounting Bulletin 800H units with legend plates either side by side or one above the other in third-party enclosures. Minimum spacing without legend plate: When units are mounted so that the contact block terminals face each other, the 57.2 mm (2.25 in.) dimension must be used to get proper electrical clearance. When control units are mounted so that the contact block terminals do not face each other, the 46.8 mm (1.84 in.) dimension can be used.
- (2) External thread major diameter: 1.034 in. max, 1.024 in. min.
Internal thread minor diameter: 0.958 in. min, 0.970 in. max.

Panel Thickness Requirements

Standard Barrel
(devices fit panels up to 25.4 mm [1 in.])

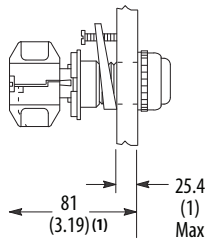

Long Barrel
(devices fit panels up to 63.5 mm [2.5 in.])

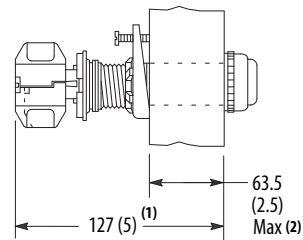

- (1) This dimension for push buttons only.
- (2) When mounting in a panel thicker than 54 mm (2.13 in.) a locking bracket is not required.

Dimensions in millimeters (inches). Dimensions are not intended to be used for manufacturing purposes.

Push Buttons

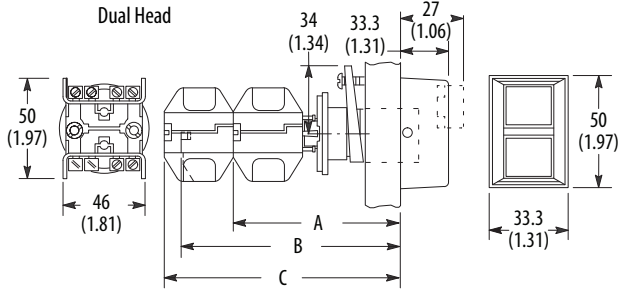

Dim.	A	B	C	Ship. Wt. [kg (oz)]
Standard Barrel	84.1 (3.31)	106.4 (4.19)	112.7 (4.44)	0.29 (10.38)
Long Barrel	116.7 (4.59)	138.9 (5.47)	145.2 (5.72)	0.37 (13)

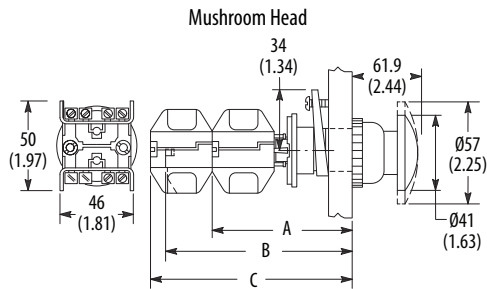

Push Button with Extra Long Guard

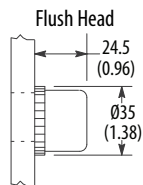
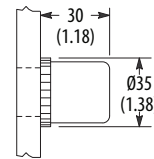

Extended Head

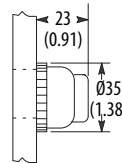

Type	Standard Barrel				Long Barrel			
	A (1)	B	C	Ship. Wt. [kg (oz)]	A (2)	B	C	Ship. Wt. [kg (oz)]
Mushroom, Flush, and Extended Head	81 (3.19)	105 (4.13)	111 (4.37)	0.28 (9.88)	127 (5)	149.2 (5.87)	155.6 (6.13)	0.38 (13.40)
Extra Long Guard	81 (3.19)	105 (4.13)	111 (4.37)	0.31 (10.93)	127 (5)	149.2 (5.87)	155.6 (6.13)	0.40 (14.11)

(1) When using sealed switch contact block, this dimension is 103 mm (4.06 in.).

(2) When using sealed switch contact block, this dimension is 149.2 mm (5.87 in.).

Dimensions in millimeters (inches). Dimensions are not intended to be used for manufacturing purposes.

Selector Switches

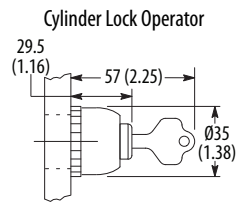
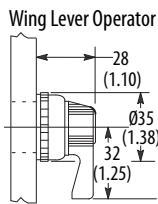
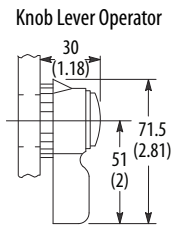
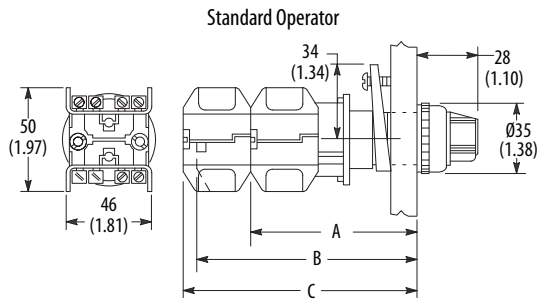

Type	Standard Barrel				Long Barrel			
	A ⁽¹⁾	B	C	Ship. Wt. [kg (oz)]	A ⁽²⁾	B	C	Ship. Wt. [kg (oz)]
Standard and Knob Lever	81 (3.19)	105 (4.13)	111 (4.37)	0.27 (9.52)	127 (5)	149.2 (5.87)	155.6 (6.13)	0.41 (14.46)
Wing Lever	81 (3.19)	105 (4.13)	111 (4.37)	0.30 (10.58)	127 (5)	149.2 (5.87)	155.6 (6.13)	0.43 (15)
Cylinder Lock	81 (3.19)	105 (4.13)	111 (4.37)	0.32 (11.29)	127 (5)	149.2 (5.87)	155.6 (6.13)	0.45 (16)

(1) When using sealed switch contact block, this dimension is 103 mm (4.06 in.).
 (2) When using sealed switch contact block, this dimension is 149.2 mm (5.87 in.).

Dimensions in millimeters (inches). Dimensions are not intended to be used for manufacturing purposes.

Illuminated Push Buttons or Push-to-test Pilot Lights

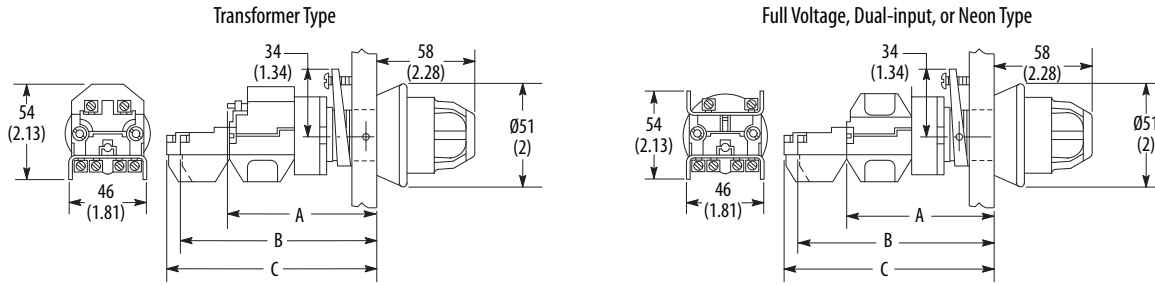

Description	Style	A ⁽¹⁾	B	C	Shipping Weight [kg (oz)]
Transformer Type	Standard Barrel	80.2 (3.16)	99 (3.90)	105 (4.13)	0.40 (14)
	Long Barrel	128.6 (5.06)	147.6 (5.81)	154 (6.06)	0.45 (16.19)
Full Voltage, Dual-input, or Neon Type	Standard Barrel	77 (3.03)	99 (3.90)	105 (4.13)	0.33 (11.63)
	Long Barrel	125.4 (4.94)	147.6 (5.81)	154 (6.06)	0.38 (13.44)

(1) When using sealed switch contact block, add 22.2 mm (0.88 in.) to the listed dimension.

Push-pull Units

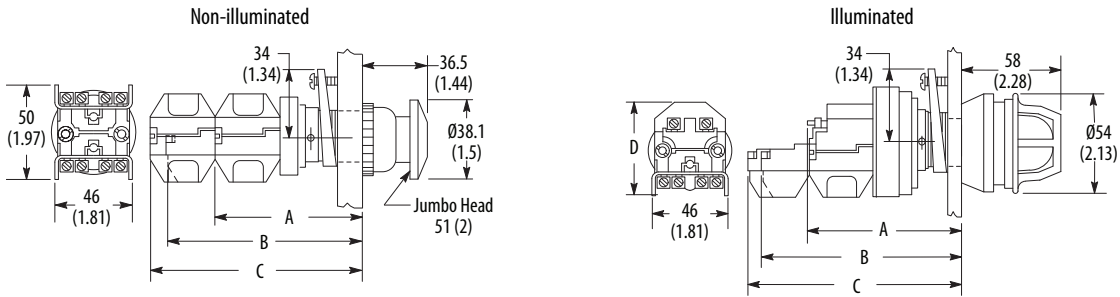

Description	Style	A ⁽¹⁾	B	C	D	Shipping Weight [kg (oz)]
Illuminated Transformer Type	Standard Barrel	90.5 (3.56)	115.9 (4.56)	117.5 (4.63)	54 (2.13)	0.44 (15.5)
	Long Barrel	118.3 (4.66)	137 (5.39)	143.7 (5.66)	54 (2.13)	0.49 (17.44)
Illuminated Full Voltage Type	Standard Barrel	87.3 (3.44)	115.9 (4.56)	117.5 (4.63)	50 (1.97)	0.36 (12.81)
	Long Barrel	115.1 (4.53)	137 (5.39)	143.7 (5.66)	50 (1.97)	0.41 (14.75)
Non-illuminated Push-pull Units	Standard Barrel	88.9 (3.50)	111.1 (4.37)	117.5 (4.63)	—	0.32 (11.13)
	Long Barrel	115.1 (4.53)	137 (5.39)	143.7 (5.66)	—	0.34 (12.31)

(1) When using sealed switch contact block, add 22.2 mm (0.88 in.) to the listed dimension.

Dimensions in millimeters (inches). Dimensions are not intended to be used for manufacturing purposes.

Pilot Lights

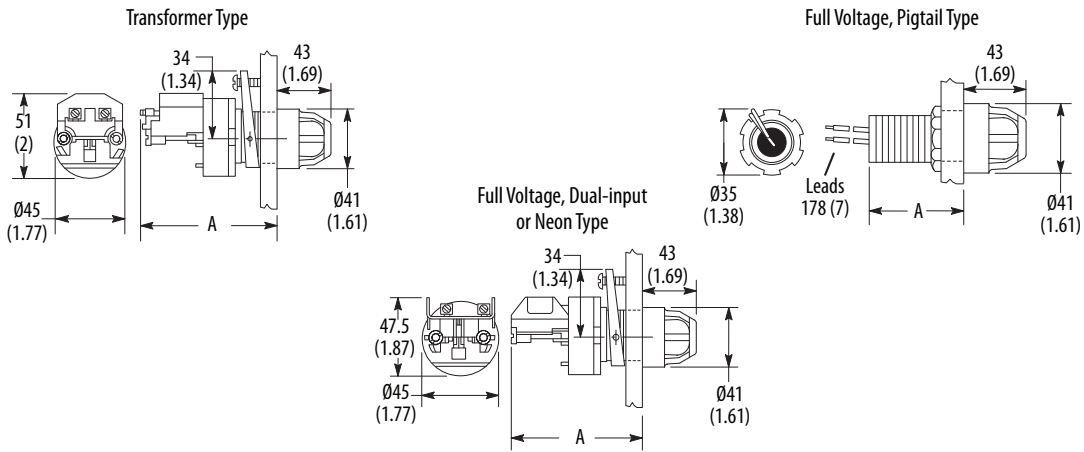

Description	Style	A	Shipping Weight [kg (oz)]
Transformer type and dual-input transformer-type pilot lights	Standard Barrel	80 (3.16)	0.24 (8.56)
	Long Barrel	115.9 (4.56)	0.85 (30.25)
Full voltage, neon, or dual-input diode and resistor-type pilot lights	Standard Barrel	77 (3.03)	0.17 (5.81)
	Long Barrel	112.7 (4.44)	0.77 (27.5)
Full-voltage pigtail-type pilot lights	Standard Barrel	55.5 (2.19)	0.16 (5.63)
	Long Barrel	94 (3.70)	0.24 (8.31)

Potentiometer Units

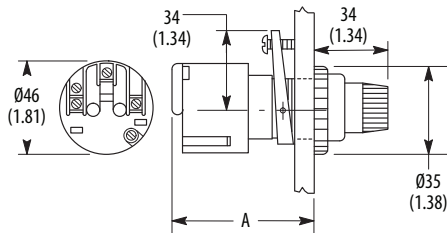

Style	A	Shipping Weight [kg (oz)]
Standard Barrel	79.5 (3.13)	0.16 (5.38)
Long Barrel	114.3 (4.5)	0.23 (8)

Dimensions in millimeters (inches). Dimensions are not intended to be used for manufacturing purposes.

Shallow Base Stations

Shallow Base Station Lever Type

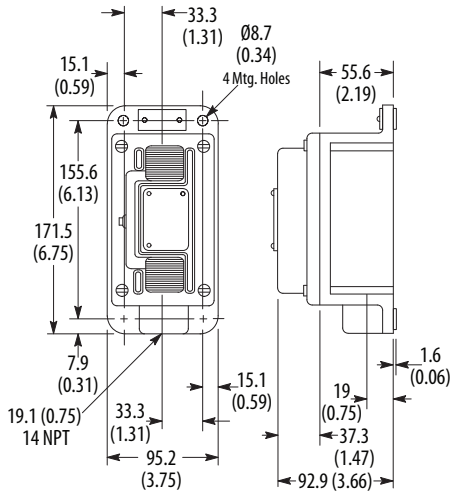

Shipping Weight 1.36 kg (3 lb)

Shallow Base Station Component Type
1-Gang (one or two devices)

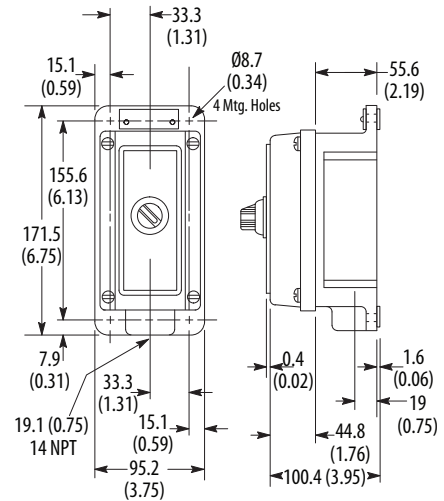

Shipping Weight 1.58 kg (3.5 lb)

Deep Base Stations

Deep Base Station Lever Type
1-Gang

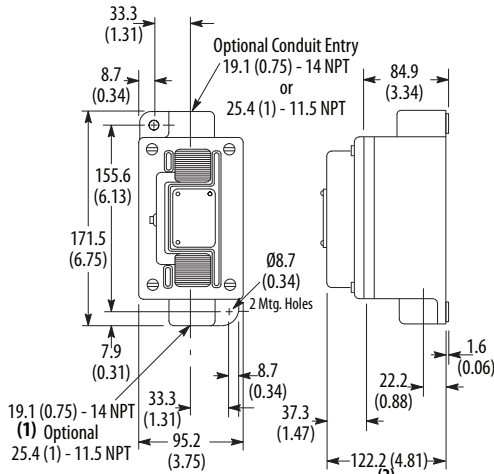

Shipping Weight 1.81 kg (4 lb)

Deep Base Component Lever Type
1-Gang (one or two devices)

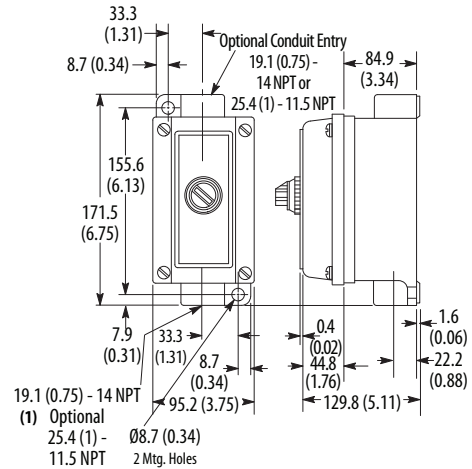

Shipping Weight 2.04 kg (4.5 lb)

(1) When using a flange seal, an approved drain fitting must be provided (refer to National Electrical Code).

(2) When used, add the following to the max depth: flange seal adds 4.8 mm (0.19 in.); sealing well with integral flange seal adds 12.7 mm (0.5 in.).

Dimensions in millimeters (inches). Dimensions are not intended to be used for manufacturing purposes.

Factory-assembled Stations

For depth dimensions, see [Deep Base Stations](#) on page 35.

Control Station, 2-Gang (up to four devices)

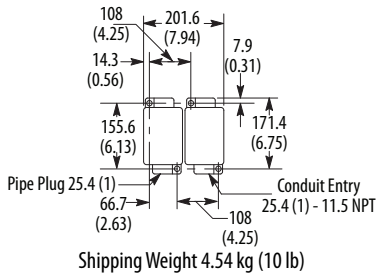

Control Station, 3-Gang (up to six devices)

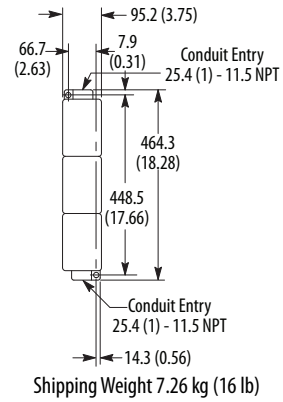

Control Station, 2-Gang (up to four devices)

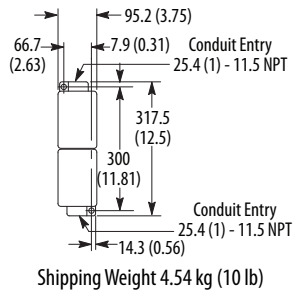

Control Station, 4-Gang (up to eight devices)

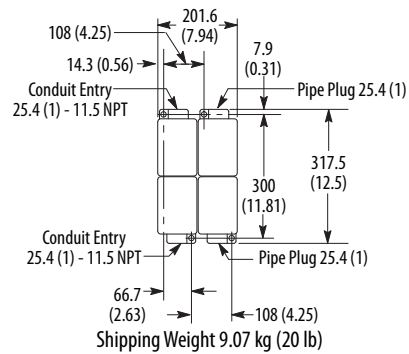

Control Station, 6-Gang (up to 12 devices)

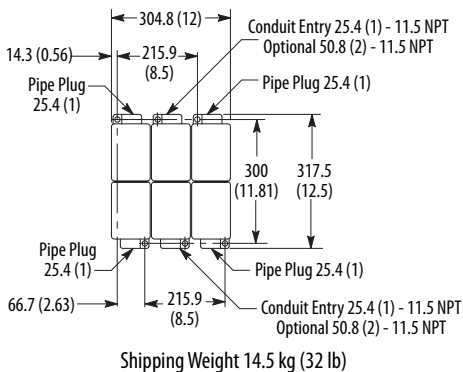

Control Station, 8-Gang (up to 16 devices)

