

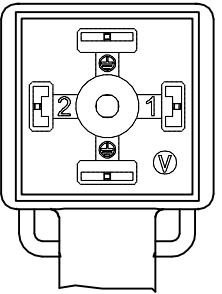

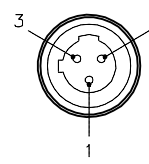

VALVE END VIEW	MALE END VIEW	WIRING DIAGRAM	SPECIFICATIONS																						
 <p>1 = BLACK #1 2 = BLACK #2 GND = GREEN/YELLOW</p>	 <p>1 = GREEN/YELLOW 2 = BLACK#1 3 = BLACK#2</p> 		<table border="1" style="width:100%; border-collapse: collapse;"> <tr><td>CONTACT CARRIER MATERIAL</td><td>NYLON</td></tr> <tr><td>MOLDED HEAD MATERIAL/COLOR</td><td>TPU/TRANSLUCENT BLACK (J1), YELLOW (P1)</td></tr> <tr><td>CONTACT MATERIAL/PLATING</td><td>BRASS/SILVER (J1), BRASS/GOLD (P1)</td></tr> <tr><td>COUPLING NUT MATERIAL/PLATING</td><td>BRASS/NICKEL (P1)</td></tr> <tr><td>RATED CURRENT [A]</td><td>4.0 A</td></tr> <tr><td>RATED VOLTAGE [V]</td><td>110-220 VAC/DC</td></tr> <tr><td>OUTER CABLE JACKET MATERIAL/COLOR</td><td>PVC/GRAY</td></tr> <tr><td>CONDUCTOR INSULATION MATERIAL</td><td>PVC</td></tr> <tr><td>NUMBER OF CONDUCTORS [AWG]</td><td>3x18 AWG</td></tr> <tr><td>TEMPERATURE RANGE</td><td>-40°C to +105°C (-40°F to +221°F)</td></tr> <tr><td>PROTECTION CLASS</td><td>MEETS NEMA 1,3,4,6P AND IEC IP67</td></tr> </table>	CONTACT CARRIER MATERIAL	NYLON	MOLDED HEAD MATERIAL/COLOR	TPU/TRANSLUCENT BLACK (J1), YELLOW (P1)	CONTACT MATERIAL/PLATING	BRASS/SILVER (J1), BRASS/GOLD (P1)	COUPLING NUT MATERIAL/PLATING	BRASS/NICKEL (P1)	RATED CURRENT [A]	4.0 A	RATED VOLTAGE [V]	110-220 VAC/DC	OUTER CABLE JACKET MATERIAL/COLOR	PVC/GRAY	CONDUCTOR INSULATION MATERIAL	PVC	NUMBER OF CONDUCTORS [AWG]	3x18 AWG	TEMPERATURE RANGE	-40°C to +105°C (-40°F to +221°F)	PROTECTION CLASS	MEETS NEMA 1,3,4,6P AND IEC IP67
CONTACT CARRIER MATERIAL	NYLON																								
MOLDED HEAD MATERIAL/COLOR	TPU/TRANSLUCENT BLACK (J1), YELLOW (P1)																								
CONTACT MATERIAL/PLATING	BRASS/SILVER (J1), BRASS/GOLD (P1)																								
COUPLING NUT MATERIAL/PLATING	BRASS/NICKEL (P1)																								
RATED CURRENT [A]	4.0 A																								
RATED VOLTAGE [V]	110-220 VAC/DC																								
OUTER CABLE JACKET MATERIAL/COLOR	PVC/GRAY																								
CONDUCTOR INSULATION MATERIAL	PVC																								
NUMBER OF CONDUCTORS [AWG]	3x18 AWG																								
TEMPERATURE RANGE	-40°C to +105°C (-40°F to +221°F)																								
PROTECTION CLASS	MEETS NEMA 1,3,4,6P AND IEC IP67																								

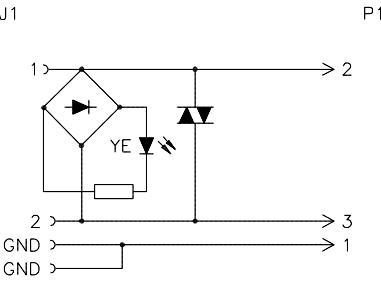
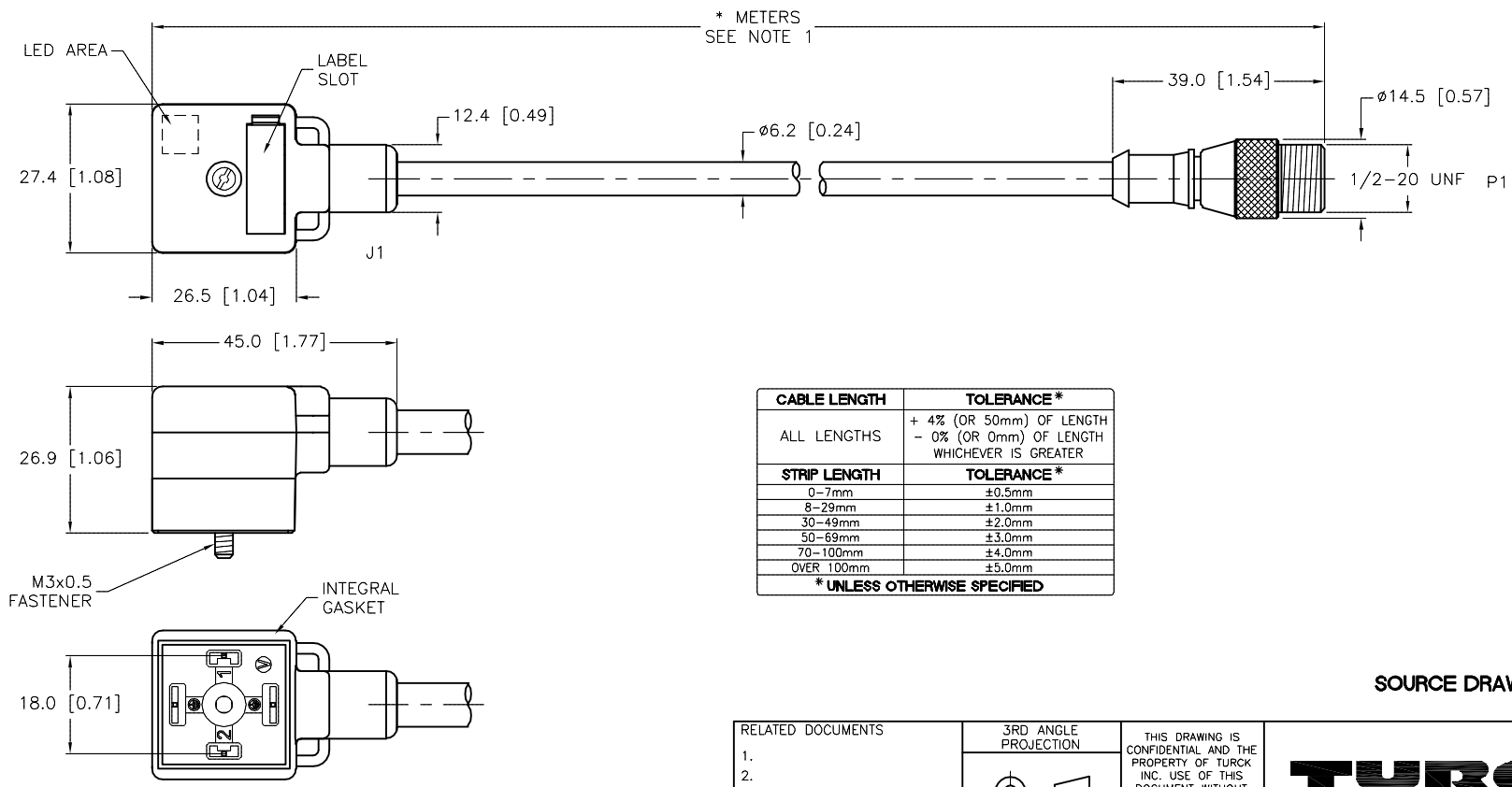

CABLE LENGTH	TOLERANCE *
ALL LENGTHS	+ 4% (OR 50mm) OF LENGTH - 0% (OR 0mm) OF LENGTH WHICHEVER IS GREATER
STRIP LENGTH	TOLERANCE *
0-7mm	±0.5mm
8-29mm	±1.0mm
30-49mm	±2.0mm
50-69mm	±3.0mm
70-100mm	±4.0mm
OVER 100mm	±5.0mm
* UNLESS OTHERWISE SPECIFIED	

NOTES:
1. "*" INDICATES CABLE LENGTH IN METERS. CONTACT TURCK TO ORDER SPECIFIC LENGTHS.

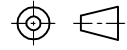
SOURCE DRAWING - FOR REFERENCE ONLY

RELATED DOCUMENTS 1. 2. 3. 4.	3RD ANGLE PROJECTION 	THIS DRAWING IS CONFIDENTIAL AND THE PROPERTY OF TURCK INC. USE OF THIS DOCUMENT WITHOUT WRITTEN PERMISSION IS PROHIBITED.		3000 CAMPUS DRIVE MINNEAPOLIS, MN 55441 1-800-544-7769 (763) 553-7300 (763) 553-0708 fax www.turck.us
MATERIAL	SEE SPECIFICATIONS	DRFT KMY	DATE 02/05/13	DESCRIPTION VAS 22-E653-*M-SB 3T
FINISH	SEE SPECIFICATIONS	APVD	SCALE 1=1.3	IDENTIFICATION NO.
		UNIT OF MEASUREMENT MILLIMETER [INCH]		REV A
		DO NOT SCALE THIS DRAWING		FILE: 777015255
				SHEET 1 OF 1

A	DRAWING RELEASE	RDS	02/08/13	41241
REV	DESCRIPTION	BY	DATE	ECO NO.