

Visualisation; Diagnostics

Easy to Configure

Programming IEC 61131-3

Rapid Installation

PNOZ mi1p

PILZ

THE SPIRIT OF SAFETY

- ▶ Configurable safety systems PNOZmulti

This document is a translation of the original document.

All rights to this documentation are reserved by Pilz GmbH & Co. KG. Copies may be made for internal purposes. Suggestions and comments for improving this documentation will be gratefully received.

Source code from third-party manufacturers or open source software has been used for some components. The relevant licence information is available on the Internet on the Pilz homepage.

Pilz®, PIT®, PMI®, PNOZ®, Primo®, PSEN®, PSS®, PVIS®, SafetyBUS p®, SafetyEYE®, SafetyNET p®, the spirit of safety® are registered and protected trademarks of Pilz GmbH & Co. KG in some countries.



SD means Secure Digital

Section 1	Introduction	4
	1.1 Validity of documentation	4
	1.2 Using the documentation	4
	1.3 Definition of symbols	4
Section 2	Overview	6
	2.1 Scope	6
	2.2 Unit features	6
	2.3 Front view	7
Section 3	Safety	8
	3.1 Intended use	8
	3.2 System requirements	8
	3.3 Safety regulations	8
	3.3.1 Safety assessment	8
	3.3.2 Use of qualified personnel	9
	3.3.3 Warranty and liability	9
	3.3.4 Disposal	9
	3.3.5 For your safety	9
Section 4	Function description	10
	4.1 Integrated protection mechanisms	10
	4.2 Functions	10
	4.3 System reaction time	10
	4.4 Block diagram	10
Section 5	Installation	11
	5.1 General installation guidelines	11
	5.2 Dimensions in mm	11
	5.3 Connecting the base unit and expansion modules	12
Section 6	Commissioning	13
	6.1 General wiring guidelines	13
	6.2 Preparing for operation	13
	6.3 Connection	13
	6.4 Connection example	14
	6.5 Download modified project to the PNOZmulti system	14
Section 7	Operation	15
	7.1 Messages	15
Section 8	Technical details	16
	8.1 Safety characteristic data	18
Section 9	Order reference	20
	9.1 Product	20
	9.2 Accessories	20

1 Introduction

1.1 Validity of documentation

This documentation is valid for the product PNOZ mi1p from Version 4.0 .

This operating manual explains the function and operation, describes the installation and provides guidelines on how to connect the product.

1.2 Using the documentation

This document is intended for instruction. Only install and commission the product if you have read and understood this document. The document should be retained for future reference.

1.3 Definition of symbols

Information that is particularly important is identified as follows:



DANGER!

This warning must be heeded! It warns of a hazardous situation that poses an immediate threat of serious injury and death and indicates preventive measures that can be taken.



WARNING!

This warning must be heeded! It warns of a hazardous situation that could lead to serious injury and death and indicates preventive measures that can be taken.



CAUTION!

This refers to a hazard that can lead to a less serious or minor injury plus material damage, and also provides information on preventive measures that can be taken.



NOTICE

This describes a situation in which the product or devices could be damaged and also provides information on preventive measures that can be taken. It also highlights areas within the text that are of particular importance.

**INFORMATION**

This gives advice on applications and provides information on special features.

2 Overview

2.1 Scope

- ▶ Expansion module PNOZ mi1p
- ▶ Jumper

2.2 Unit features

The product has the following features:

- ▶ 8 inputs for connecting:
 - E-STOP pushbuttons
 - Two-hand button
 - Safety gate limit switches
 - Start buttons
 - Light beam devices
 - Scanners
 - Enabling switches
 - PSEN
 - Operating mode selector switches
- ▶ Can be configured in the PNOZmulti Configurator
- ▶ LED indicator for:
 - Status of PNOZmulti
- ▶ Max. 8 PNOZ mi1p units can be connected to the base unit
- ▶ Test pulse outputs used to monitor shorts across the inputs
- ▶ Plug-in connection terminals (either cage clamp terminal or screw terminal)
- ▶ Coated version:
 - Increased environmental requirements (see [Technical details](#)  16)

2.3 Front view

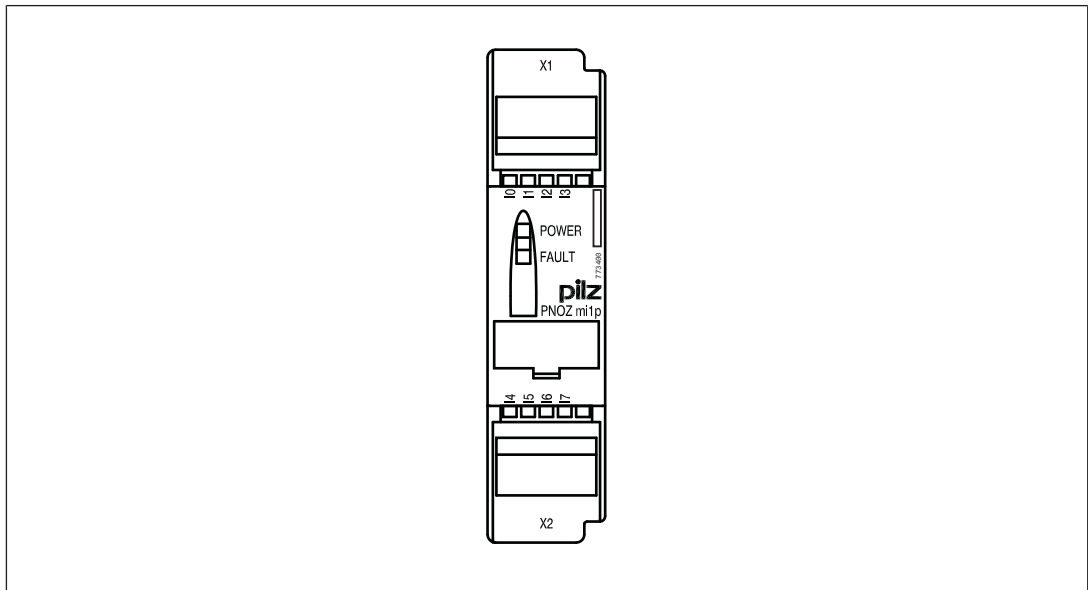

Legend:

- ▶ Inputs I0 – I7

3 Safety

3.1 Intended use

The expansion module may only be connected to a base unit from the PNOZmulti system (please refer to the document "PNOZmulti System Expansion" for details of the base units that can be connected).

The configurable small control systems PNOZmulti are used for the safety-related interruption of safety circuits and are designed for use in:

- ▶ E-STOP equipment
- ▶ Safety circuits in accordance with VDE 0113 Part 1 and EN 60204-1

The coated version of the product PNOZ mi1p is suitable for use where there are increased environmental requirements (see [Technical details \[16\]](#)).

The following is deemed improper use in particular:

- ▶ Any component, technical or electrical modification to the product
- ▶ Use of the product outside the areas described in this manual
- ▶ Use of the product outside the technical details (see [Technical details \[16\]](#)).



NOTICE

EMC-compliant electrical installation

The product is designed for use in an industrial environment. The product may cause interference if installed in other environments. If installed in other environments, measures should be taken to comply with the applicable standards and directives for the respective installation site with regard to interference.

3.2 System requirements

Please refer to the "Product Modifications PNOZmulti" document in the "Version overview" section for details of which versions of the base unit and PNOZmulti Configurator can be used for this product.

3.3 Safety regulations

3.3.1 Safety assessment

Before using a unit it is necessary to perform a safety assessment in accordance with the Machinery Directive.

Functional safety is guaranteed for the product as a single component. However, this does not guarantee the functional safety of the overall plant/machine. In order to achieve the required safety level for the overall plant/machine, define the safety requirements for the plant/machine and then define how these must be implemented from a technical and organisational standpoint.

3.3.2 Use of qualified personnel

The products may only be assembled, installed, programmed, commissioned, operated, maintained and decommissioned by competent persons.

A competent person is someone who, because of their training, experience and current professional activity, has the specialist knowledge required to test, assess and operate the work equipment, devices, systems, plant and machinery in accordance with the general standards and guidelines for safety technology.

It is the company's responsibility only to employ personnel who:

- ▶ Are familiar with the basic regulations concerning health and safety / accident prevention
- ▶ Have read and understood the information provided in this description under "Safety"
- ▶ And have a good knowledge of the generic and specialist standards applicable to the specific application.

3.3.3 Warranty and liability

All claims to warranty and liability will be rendered invalid if

- ▶ The product was used contrary to the purpose for which it is intended
- ▶ Damage can be attributed to not having followed the guidelines in the manual
- ▶ Operating personnel are not suitably qualified
- ▶ Any type of modification has been made (e.g. exchanging components on the PCB boards, soldering work etc.).

3.3.4 Disposal

- ▶ In safety-related applications, please comply with the mission time T_M in the safety-related characteristic data.
- ▶ When decommissioning, please comply with local regulations regarding the disposal of electronic devices (e.g. Electrical and Electronic Equipment Act).

3.3.5 For your safety

The unit meets all the necessary conditions for safe operation. However, you should always ensure that the following safety requirements are met:

- ▶ This operating manual only describes the basic functions of the unit. The expanded functions are described in the PNOZmulti Configurator's online help. Only use these functions once you have read and understood the documentations.
- ▶ Do not open the housing or make any unauthorised modifications.
- ▶ Please make sure you shut down the supply voltage when performing maintenance work (e.g. exchanging contactors).

4 Function description

4.1 Integrated protection mechanisms

The relay conforms to the following safety criteria:

- ▶ The circuit is redundant with built-in self-monitoring.
- ▶ The safety function remains effective in the case of a component failure.

4.2 Functions

The expansion module provides additional inputs.

The function of the inputs on the safety system depends on the safety circuit created using the PNOZmulti Configurator. A chip card is used to download the safety circuit to the base unit. The base unit has 2 microcontrollers that monitor each other. They evaluate the input circuits on the base unit and expansion modules and switch the outputs on the base unit and expansion modules accordingly.

The online help on the PNOZmulti Configurator contains descriptions of the operating modes and all the functions of the PNOZmulti safety system, plus connection examples.

4.3 System reaction time

Calculation of the maximum reaction time between an input switching off and a linked output in the system switching off is described in the document "PNOZmulti System Expansion".

4.4 Block diagram

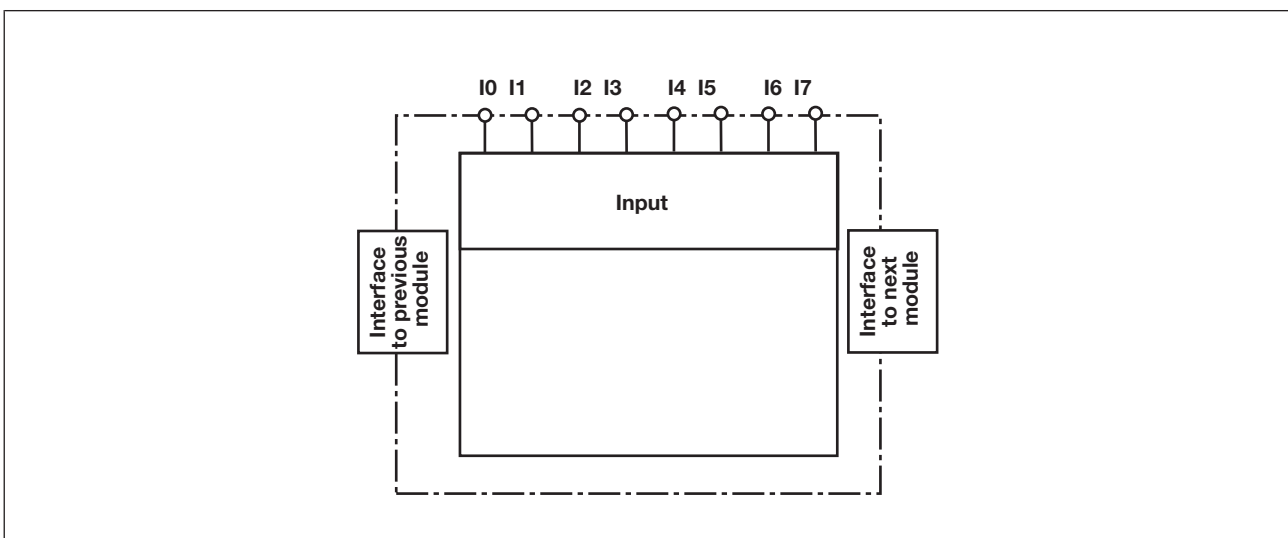

5 Installation

5.1 General installation guidelines

- ▶ The control system should be installed in a control cabinet with a protection type of at least IP54. Fit the control system to a horizontal mounting rail. The venting slots must face upward and downward. Other mounting positions could destroy the control system.
- ▶ Use the notches on the rear of the unit to attach it to a mounting rail. Connect the control system to the mounting rail in an upright position, so that the earthing springs on the control system are pressed on to the mounting rail.
- ▶ The ambient temperature of the PNOZmulti units in the control cabinet must not exceed the figure stated in the technical details, otherwise air conditioning will be required.
- ▶ To comply with EMC requirements, the mounting rail must have a low impedance connection to the control cabinet housing.



CAUTION!

Damage due to electrostatic discharge!

Electrostatic discharge can damage components. Ensure against discharge before touching the product, e.g. by touching an earthed, conductive surface or by wearing an earthed armband.

5.2 Dimensions in mm

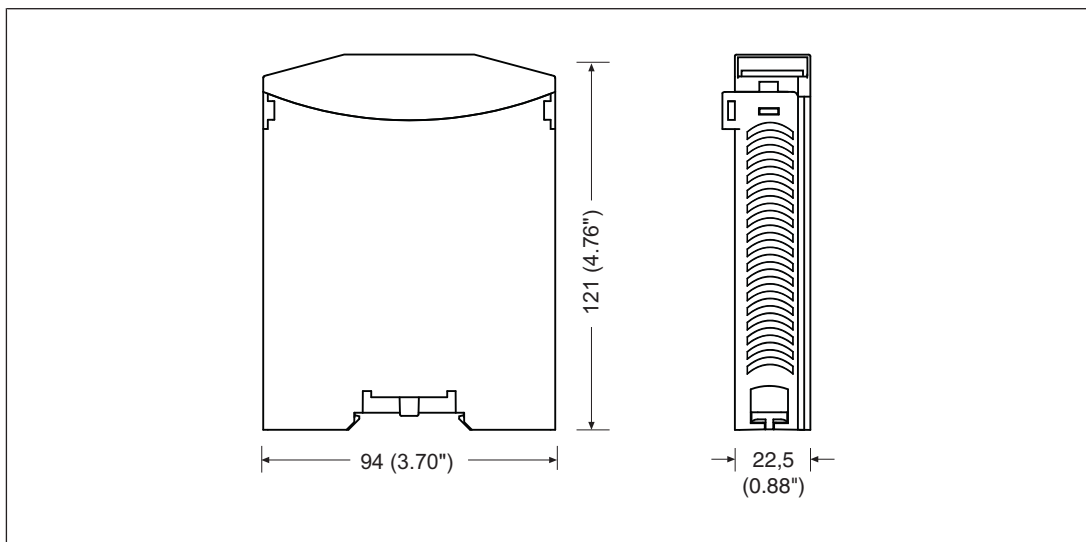

5.3 Connecting the base unit and expansion modules

Connect the base unit and the expansion modules as described in the operating manuals for the base modules.

- ▶ The terminator must be fitted to the last expansion module
- ▶ Install the expansion module in the position configured in the PNOZmulti Configurator.

The position of the expansion modules is defined in the PNOZmulti Configurator. The expansion modules are connected to the left or right of the base unit, depending on the type.

Please refer to the document "PNOZmulti System Expansion" for details of the number of modules that can be connected to the base unit and the module types.

6 Commissioning

6.1 General wiring guidelines

The wiring is defined in the circuit diagram of the PNOZmulti Configurator.

Please note:

- ▶ Information given in the [Technical details](#) [16] must be followed.
- ▶ Use copper wire that can withstand 75° C.
- ▶ The safety system and input circuits must always be supplied by a single power supply. The power supply must meet the regulations for extra low voltages with protective separation.

6.2 Preparing for operation

The N/C contact on the trigger element (e.g. E-STOP) must be connected to the input circuit. A short circuit in the input circuit may or may not be detected, depending on the configuration and wiring. The test pulse outputs on the base unit must be used to detect shorts across contacts. The input assignment is defined in the PNOZmulti Configurator.

The input circuit should be connected as described in the table. The wiring at I0 and I1 is illustrated as an example; inputs I2 ... 17 are wired in a similar way.

6.3 Connection

Input circuit	Single-channel	Dual-channel
Example: E-Stop without detection of shorts across contacts		
Example: E-Stop with detection of shorts across contacts		

Input circuit

6.4 Connection example

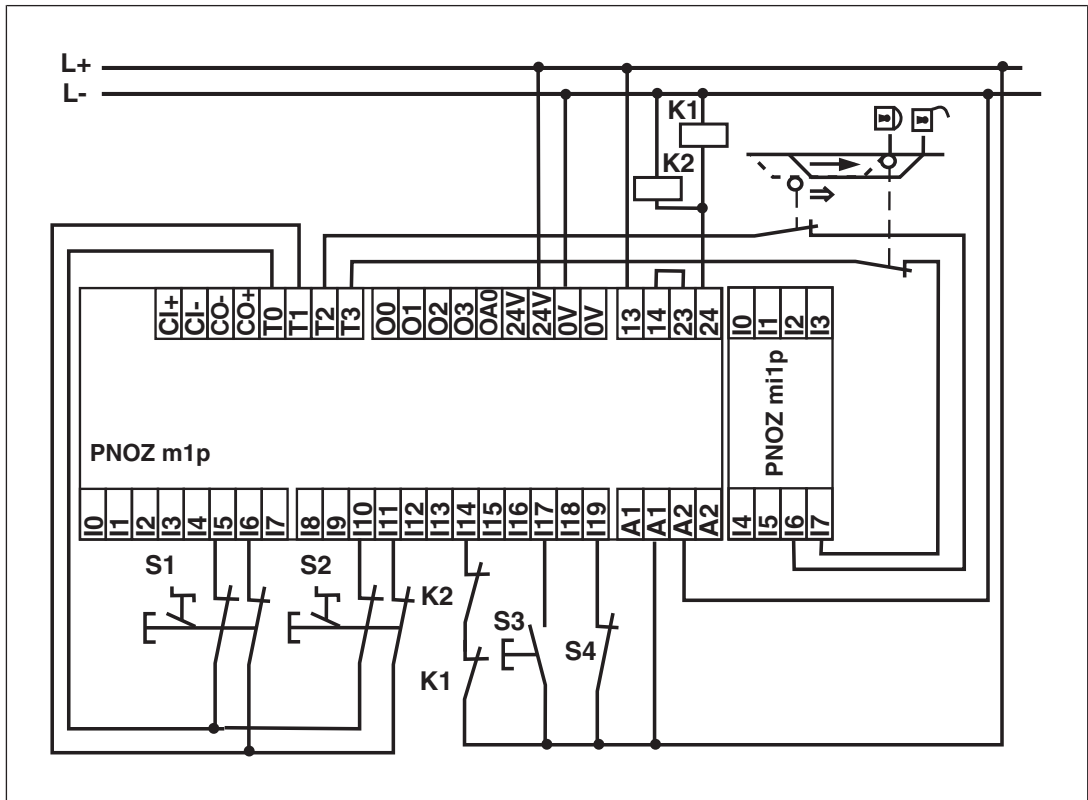

6.5 Download modified project to the PNOZmulti system

As soon as an additional expansion module has been connected to the system, the project must be amended using the PNOZmulti Configurator. Proceed as described in the operating instructions for the base unit.



NOTICE

For the commissioning and after every program change, you must check whether the safety devices are functioning correctly.

7 Operation

When the supply voltage is switched on, the PNOZmulti safety system copies the configuration from the chip card.

The LEDs "POWER", "DIAG", "FAULT", "IFAUULT" and "OFAULT" will light up on the base unit.



The PNOZmulti safety system is ready for operation when the "POWER" and "RUN" LEDs on the base unit are lit continuously.





Status indicators:

- ▶ I0 ... I7 lights: Safety input I0 ... I7 carries a high signal.
- ▶ I0 ... I7 does not light: Safety input I0 ... I7 carries a low signal.

7.1 Messages

Legend

-  LED on
-  LED flashes
-  LED off

Base unit						PNOZ mi1p		Error
Input Ix	RUN	DIAG	FAULT	IFAUULT	OFAULT	FAULT	Input Ix	
								External fault at the input, which leads to a safe state. The fault or short across the contact is at the inputs whose LEDs are flashing
								Internal error on the expansion module

8 Technical details

General	773400	773405
Approvals	BG, CCC, CE, EAC (Eurasian), KOSHA, TÜV, cULus Listed	BG, CCC, CE, EAC (Eurasian), KOSHA, TÜV, cULus Listed
Electrical data	773400	773405
Supply voltage		
for	Module supply	Module supply
internal	Via base unit	Via base unit
Voltage	5,0 V	5,0 V
Kind	DC	DC
Voltage tolerance	-2 %/+2 %	-2 %/+2 %
Power consumption	2,5 W	2,5 W
Status indicator	LED	LED
Inputs	773400	773405
Number	8	8
Signal level at "0"	-3 - +5 V DC	-3 - +5 V DC
Signal level at "1"	15 - 30 V DC	15 - 30 V DC
Input voltage in accordance with EN 61131-2 Type 1	24 V DC	24 V DC
Min. pulse duration	18 ms	18 ms
Pulse suppression	0,6 ms	0,6 ms
Maximum input delay	4 ms	4 ms
Potential isolation	No	No
Times	773400	773405
Switch-on delay	5,00 s	5,00 s
Supply interruption before de-energisation	20 ms	20 ms
Simultaneity, channel 1 and 2 max.	3 s	3 s
Simultaneity in the two-hand circuit	0,5 s	0,5 s
Environmental data	773400	773405
Ambient temperature		
In accordance with the standard	EN 60068-2-14	EN 60068-2-14
Temperature range	0 - 60 °C	-25 - 60 °C
Forced convection in control cabinet off	55 °C	—
Storage temperature		
In accordance with the standard	EN 60068-2-1/-2	EN 60068-2-1/-2
Temperature range	-25 - 70 °C	-25 - 70 °C
Climatic suitability		
In accordance with the standard	EN 60068-2-30, EN 60068-2-78	EN 60068-2-30, EN 60068-2-78
Humidity	93 % r. h. at 40 °C	93 % r. h. at 40 °C
Condensation during operation	Not permitted	Short-term
EMC	EN 61131-2	EN 61131-2

Environmental data	773400	773405
Vibration		
In accordance with the standard	EN 60068-2-6	EN 60068-2-6
Frequency	10,0 - 150,0 Hz	5,0 - 500,0 Hz
Acceleration	1g	1g
Broadband noise		
In accordance with the standard	–	EN 60068-2-64
Frequency	–	5 - 500 Hz
Acceleration	–	1,9grms
Corrosive gas check		
SO ₂ : Concentration 10 ppm, duration 10 days, passive	–	DIN V 40046-36
H ₂ S: Concentration 1 ppm, duration 10 days, passive	–	DIN V 40046-37
Shock stress		
In accordance with the standard	EN 60068-2-27	EN 60068-2-27
Acceleration	15g	15g
Duration	11 ms	11 ms
Max. operating height above sea level	2000 m	2000 m
Airgap creepage		
In accordance with the standard	EN 61131-2	EN 61131-2
Overvoltage category	III	III
Pollution degree	2	2
Rated insulation voltage	30 V	30 V
Protection type		
In accordance with the standard	EN 60529	EN 60529
Mounting area (e.g. control cabinet)	IP54	IP54
Housing	IP20	IP20
Terminals	IP20	IP20
Mechanical data	773400	773405
Mounting position	Horizontal on top hat rail	Horizontal on top hat rail
DIN rail		
Top hat rail	35 x 7,5 EN 50022	35 x 7,5 EN 50022
Recess width	27 mm	27 mm
Max. cable length		
Max. cable length per input	1,0 km	1,0 km
Material		
Bottom	PPO UL 94 V0	PPO UL 94 V0
Front	ABS UL 94 V0	ABS UL 94 V0
Connection type	Spring-loaded terminal, screw terminal	Spring-loaded terminal, screw terminal

Mechanical data	773400	773405
Conductor cross section with screw terminals		
1 core flexible	0,25 - 1,50 mm ² , 24 - 16 AWG	0,25 - 1,50 mm ² , 24 - 16 AWG
2 core with the same cross section, flexible without crimp connectors or with TWIN crimp connectors	0,25 - 0,75 mm ² , 24 - 20 AWG	0,25 - 0,75 mm ² , 24 - 20 AWG
Torque setting with screw terminals	0,25 Nm	0,25 Nm
Stripping length with screw terminals	7 mm	7 mm
Conductor cross section with spring-loaded terminals		
1 core flexible without crimp connector	0,25 - 1,50 mm ² , 24 - 16 AWG	0,25 - 1,50 mm ² , 24 - 16 AWG
1 core flexible with crimp connector	0,25 - 0,75 mm ² , 24 - 20 AWG	0,25 - 0,75 mm ² , 24 - 20 AWG
Spring-loaded terminals: Terminal points per connection	1	1
Stripping length with spring-loaded terminals	9 mm	9 mm
Dimensions		
Height	94,0 mm	94,0 mm
Width	22,5 mm	22,5 mm
Depth	121,0 mm	121,0 mm
Weight	120 g	123 g

Where standards are undated, the 2008-03 latest editions shall apply.

8.1 Safety characteristic data



NOTICE

You must comply with the safety-related characteristic data in order to achieve the required safety level for your plant/machine.

Operating mode	EN ISO 13849-1: 2008 PL	EN ISO 13849-1: 2008 Category	EN 62061 SIL CL	EN 62061 PFH _D [1/h]	IEC 61511 SIL	IEC 61511 PFD	EN ISO 13849-1: 2008 T _M [year]
1-channel	PL d	Cat. 2	SIL CL 2	2,50E-09	SIL 2	2,20E-04	20
2-channel	PL e	Cat. 4	SIL CL 3	2,90E-10	SIL 3	4,50E-06	20
Short circuit-forming safety mats	PL d	Cat. 3	SIL CL 2	1,81E-09	SIL 2	9,34E-05	20
1-ch., pulsed light barrier	PL e	Cat. 4	SIL CL 3	2,50E-10	SIL 3	2,21E-05	20

All the units used within a safety function must be considered when calculating the safety characteristic data.

**INFORMATION**

A safety function's SIL/PL values are **not** identical to the SIL/PL values of the units that are used and may be different. We recommend that you use the PAscal software tool to calculate the safety function's SIL/PL values.

9 Order reference

9.1 Product

Product type	Features	Order No.
PNOZ mi1p	Expansion module, 8 inputs	773 400
PNOZ mi1p coated version	Expansion module, 8 inputs, coated version	773 405

9.2 Accessories

Connection terminals

Product type	Features	Order No.
Set spring terminals	1 set of spring-loaded terminals	783 400
Set screw terminals	1 set of screw terminals	793 400

Terminator, jumper

Product type	Features	Order No.
PNOZmulti bus terminator	Terminator	779 110
PNOZmulti bus terminator coated	Terminator, coated version	779 112
KOP-XE	Jumper	774 639
KOP-XE coated	Jumper, coated version	774 640

► Support

Technical support is available from Pilz round the clock.

Americas

Brazil

+55 11 97569-2804

Canada

+1 888-315-PILZ (315-7459)

Mexico

+52 55 5572 1300

USA (toll-free)

+1 877-PILZUSA (745-9872)

Asia

China

+86 21 60880878-216

Japan

+81 45 471-2281

South Korea

+82 31 450 0680

Australia

+61 3 95446300

Europe

Austria

+43 1 7986263-0

Belgium, Luxembourg

+32 9 3217575

France

+33 3 88104000

Germany

+49 711 3409-444

Ireland

+353 21 4804983

Italy

+39 0362 1826711

Scandinavia

+45 74436332

Spain

+34 938497433

Switzerland

+41 62 88979-30

The Netherlands

+31 347 320477

Turkey

+90 216 5775552

United Kingdom

+44 1536 462203

You can reach our international hotline on:

+49 711 3409-444

support@pilz.com

Pilz develops environmentally-friendly products using ecological materials and energy-saving technologies. Offices and production facilities are ecologically designed, environmentally-aware and energy-saving. So Pilz offers sustainability, plus the security of using energy-efficient products and environmentally-friendly solutions.



Pilz GmbH & Co. KG
 Felix-Wankel-Straße 2
 73760 Ostfildern, Germany
 Tel.: +49 711 3409-0
 Fax: +49 711 3409-133
 info@pilz.com
 www.pilz.com

