

RTE Series — Analog Timers

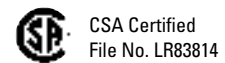

Key features of the RTE series include:

- 16 time ranges and 4 timing functions
- ON-delay, interval, OFF-delay, one-shot
- Time delays up to 10 hours
- Space-saving package (1.63" x 1.42" x 3.03")
- High repeat accuracy of $\pm 0.25\%$
- Power saving 2.2VA consumption
- ON and timing OUT LED indicators
- Standard 8- or 11-pin and 11-blade termination
- 2 form C delayed output contacts
- 10A Contact Rating



Cert. No. E9950913332316 (EMC, RTE)
 Cert. No. BL960813332355 (LVD, RTE)

Internal Circuits

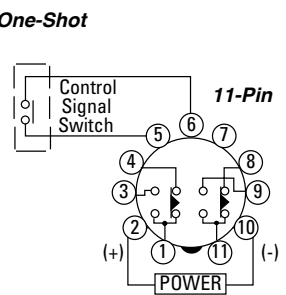
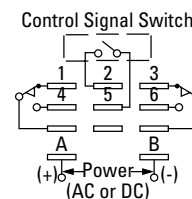
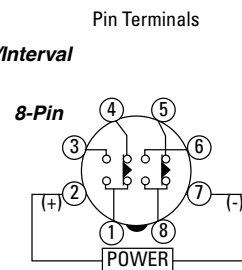
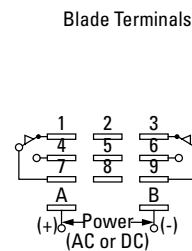

Do not apply voltage to terminals 2 and 5.

Do not apply voltage to terminals 5 and 6.

G

Specifications

Contact Configuration	2 Form C, DPDT (delay outputs)
Input Voltage	120V AC, 50/60Hz 12V AC/DC 24V AC/DC
Contact Load Rating	10A resist. at 240V AC, 30V DC 7A induct. at 240V AC, 30V DC 1/6 HP at 120V AC 1/3 HP at 240V AC
Power Consumption	ON-delay/interval AC: 1.6VA to 2.2VA DC: 0.9W to 1.2W OFF-delay/single-shot AC: 1.6VA to 2.2VA DC: 0.9W to 1.2W
Repeat Accuracy	$\pm 0.25\%$ maximum, 10ms
Voltage Accuracy	$\pm 1\%$ maximum, ± 30 ms
Temperature Error	$\pm 2\%$ maximum, ± 30 ms
Setting Error	$\pm 10\%$ maximum
Reset Time	0.1s maximum
Insulation Resistance	100 M Ω minimum
Dielectric Strength	1500V AC, 1 minute (except between contacts of same pole)
Vibration Resistance	6N (approximate 6G)
Shock Resistance	500N (approximate 50G)
Operating Temperature	-20°C to +65°C
Operating Humidity	45 to 85% RH

RTE Table of Contents

- Part Number GuideG-9
- Part Number ListG-9
- RTE Timing DiagramsG-10
- RTE AccessoriesG-11
- Instructions: Setting TimerG-13
- RTE DimensionsG-14

Part Numbering Guide

RTE series part numbers are composed of 5 part number codes. When ordering a RTE series part, select one code from each category.
 Example: RTE-P12-AC120V

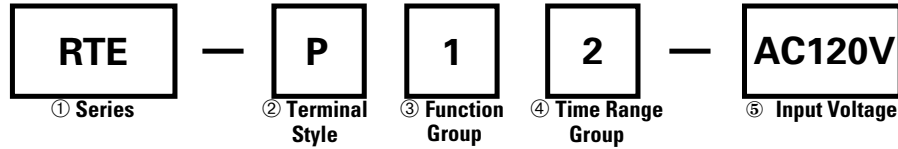

Part Numbers: RTE Series

	Description	Part Number Code	Remarks
① Series	RTE series	RTE	For internal circuits, see previous page.
② Terminal Style	Pin	P	Select one only.
	Blade	B	
③ Function Group	ON-delay/interval	1	Each function group has two timing functions. See page G-10.
	OFF-delay/one-shot	2	
④ Time Range Group	0.1s to 10 minutes	1	Each time group has 8 selectable ranges. See page G-13.
	0.1 minutes to 10 hours	2	
⑤ Input Voltage	120V AC, 50/60Hz	AC120V	
	12V AC/DC	12V	
	24V AC/DC	24V	

Part Number List

Part Numbers

Mode of Operation	Time Range	Part No.	
		Pin	Blade
ON-Delay/Interval	0.1 seconds to 10 minutes	RTE-P11	RTE-B11
	0.1 minutes to 10 hours	RTE-P12	RTE-B12
OFF-Delay/One-Shot	0.1s to 10 minutes	RTE-P21	RTE-B21
	0.1 minutes to 10 hours	RTE-P22	RTE-B22



1. After basic part number, insert input voltage.
2. For schematics, see page G-8.
3. For timing diagrams, see page G-10.
4. All timers have multiple time ranges. For a list of ranges, see page G-13.
5. For socket and accessory information, see page G-11.

Timing Diagrams

ON-Delay (delay on make):

When power is applied to the input terminals, the time delay period begins. At the end of the time delay period, the output contacts transfer. Removing power prompts a reset.

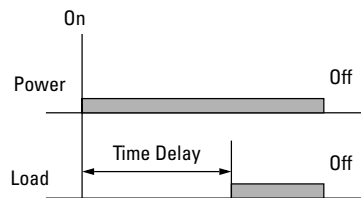

ON-Delay (RTE-P1, RTE-B1)

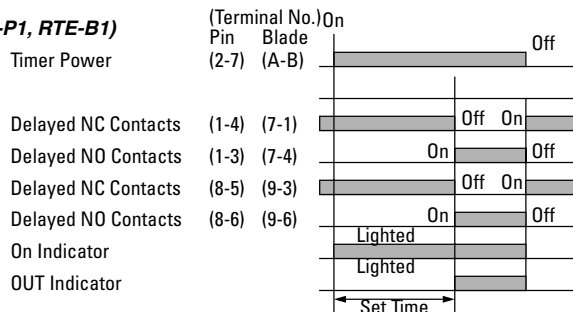

Interval:

When power is applied to the input terminals, the output contacts instantly transfer and the time delay period begins. At the end of the time delay period, the output contacts de-energize. Removing power prompts a reset.

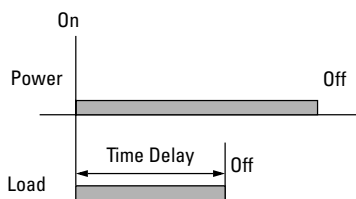

Interval (RTE-P1, RTE-B1)

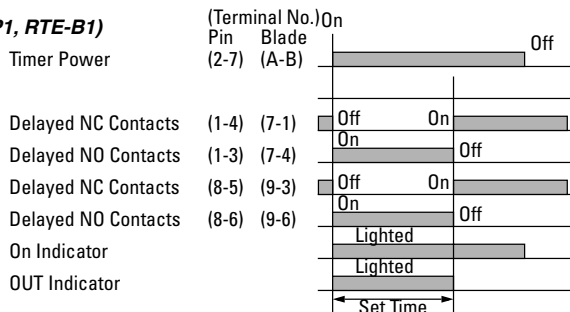

OFF-Delay (delay on break):

Power must be applied at all times to the input terminal. On closure of a normally open control signal switch, the output contacts transfer and remain in this position. When the control switch is reopened, the time delay period begins. At the end of the time delay period, the output contacts transfer back to original position. Reset occurs when the control signal switch is closed.

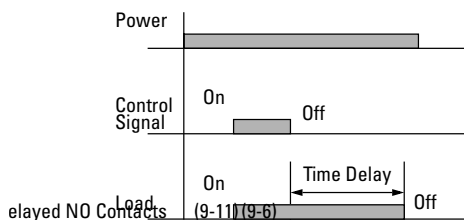

OFF-Delay (RTE-P2, RTE-B2)

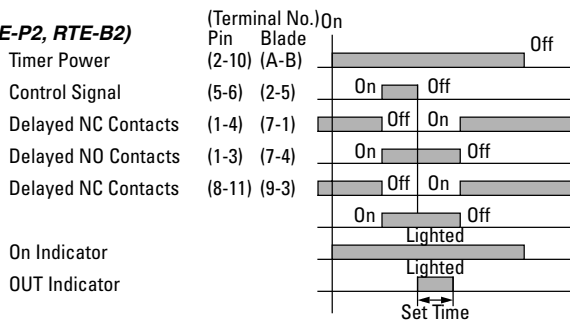

One-Shot:

Power must be applied at all times to the input terminals. On momentary or maintained closure of a normally open control signal switch, the output contacts transfer and the time delay period begins. At the end of the delay period, the output contacts transfer back to the original positions. The timer is then ready for the next timing cycle.

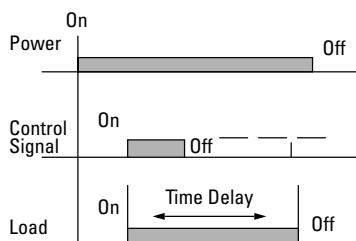

Single-Shot (RTE-P2, RTE-B2)

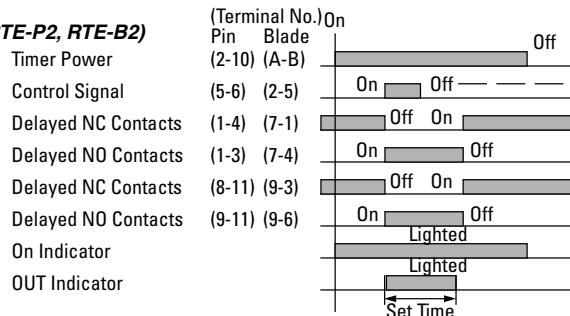

DIN Rail Mounting Accessories

Part Numbers: DIN Rail/Surface Mount Sockets and Hold-Down Springs

DIN Rail Mount Socket				Applicable Hold-Down Springs	
Style	Appearance	Use with Timers	Part No.	Appearance	Part No.
8-Pin Screw Terminal (dual tier)		RTE-P11 RTE-P12	SR2P-05		SFA-203
11-Pin Screw Terminal (dual tier)		RTE-P21 RTE-P22	SR3P-05		
8-Pin Fingersafe Socket		RTE-P11 RTE-P12	SR2P-05C		
11-Pin FingerSafe Socket		RTE-P21 RTE-P22	SR3P-05C		
8-Pin Screw Terminal		RTE-P11 RTE-P12	SR2P-06		SFA-202
11-Pin Screw Terminal		RTE-P21 RTE-P22	SR3P-06		
11-Blade Screw Terminal		RTE-B11 RTE-B12 RTE-B21 RTE-B22	SR3B-05		
DIN Mounting Rail Length 1000mm		—	BNDN1000		

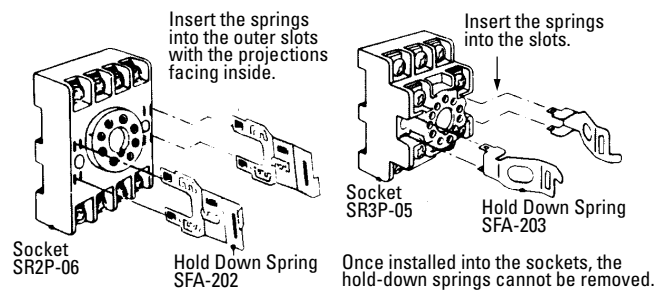

Installation of Hold-Down Springs

DIN Rail Mount Socket





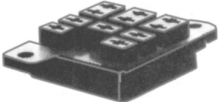

Panel Mounting Accessories

Part Numbers: Panel Mount Sockets and Hold-Down Springs

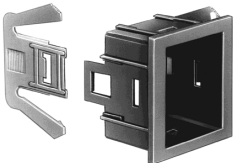
Panel Mount Socket				Applicable Hold-Down Springs	
Style	Appearance	Use with Timers	Part No.	Appearance	Part No.
8-Pin Solder Terminal		RTE-P11 RTE-P12	SR2P-51		SFA-402
11-Pin Solder Terminal		RTE-P21 RTE-P22	SR3P-51		
11-Blade Solder Terminal		RTE-B11 RTE-B12 RTE-B21 RTE-B22	SR3B-51		

Part Numbers: Flush Panel Mount Adapter and Sockets that use an Adapter

G Accessory	Description	Appearance	Use with	Part No.
Panel Mount Adapter	Adaptor for flush panel mounting RTE timers		All RTE timers	RTB-G01
Sockets for use with Panel Mount Adapter	8-pin screw terminal	 (Shown: SR6P-M08G for Wiring Socket)	RTE-P11 RTE-P12	SR6P-M08G
	11-pin screw terminal		RTE-P21 RTE-P22	SR6P-M11G
	8-pin solder terminal		RTE-P11 RTE-P12	SR6P-S08
	11-pin solder terminal		RTE-P21 RTE-P22	SR6P-S11



No hold down clips are available for flush panel mounting applications.

Instructions

Each RTE series electronic timer is available with two functions (operation modes) and eight time ranges. Start by determining which timing function and what time range suits your application.

Function Programming

1. Face Plate Removal

Bend the faceplate slightly and pop out the bottom edge (figure 1).

2. Timing Function Selection

Select the function by moving the DIP switch to the right or left position (Figure 2). Refer to the table below noting that the function group is the first digit in the part number. After the face plate is replaced, the DIP switch will be visible through the window if it is in the left position. (This is helpful for determining in which mode the timer is set, without removing the faceplate.)

Function Group	DIP Switch Position	
	Left	Right
1	Interval	ON-Delay
2	One-Shot	OFF-Delay

Time Range Programming

1. Time Range Selection

Select the appropriate timer range by rotating the digital switch (figure 2). Refer to the table below and note that the time range group is the second digit in the part number.

Time Range Group	Digital Switch Setting							
	0 (*8)	1** (9)	2	3	4	5	6	7
1	1s	3s	6s	10s	60s	30s	5 min.	10 min.
2	1 min.	3 min.	6 min.	10 min.	60 min.	30 min.	5 hrs.	10 hrs.

*The time setting is the same when the digital switch is at 0 or 8.

** The time setting is the same when the digital switch is at 1 or 9.

2. Faceplate Configuration

Rotate the wheel in the faceplate to correspond with the time range selected in the previous step (figure 3).

Time Range Group	Time Range				Face Plate Color
1	3s	6s	30s	60s	Yellow
	1s	10s	5 min.	10 min.	Pink
2	3 min.	6 min.	30 min.	60 min.	Violet
	1 min.	10 min.	5 hrs.	10 hrs.	Blue

3. Replacing Faceplate

Bend faceplate slightly and replace on the timer (figure 4). The digital switch setting should be visible through a window in the faceplate.

RTE-P21-AC120V

Function Group

Time Range Group

Figure 1

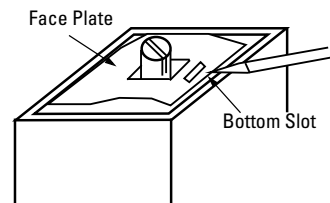

Figure 2

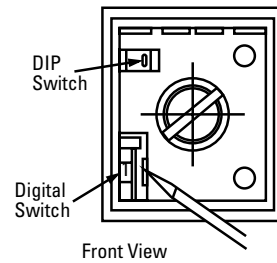

Figure 3

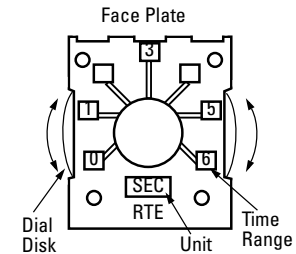
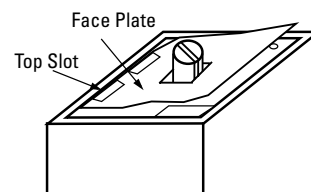

Figure 4



Dimensions

Dimensions in inches (mm)

Front View

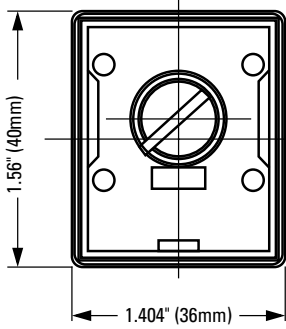

8-Pin Terminal

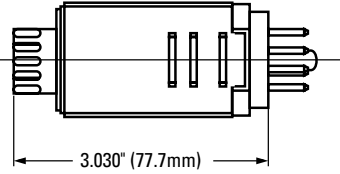

11-Pin Terminal

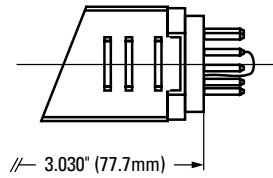

11-Blade Terminal

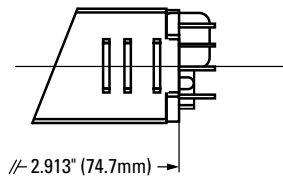

SR2P-06 Socket

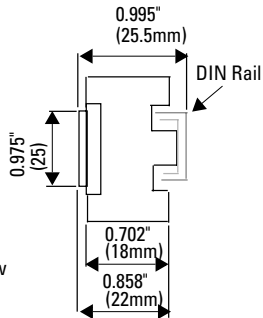
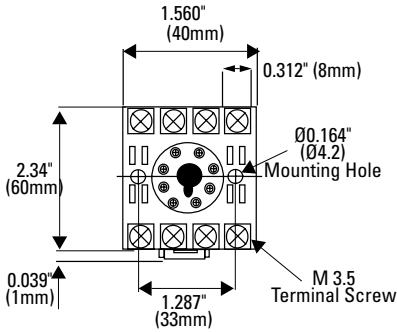

SR3P-06 Socket

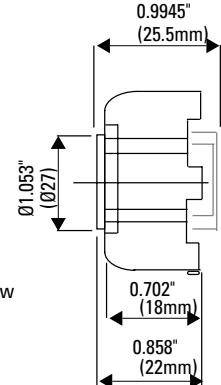
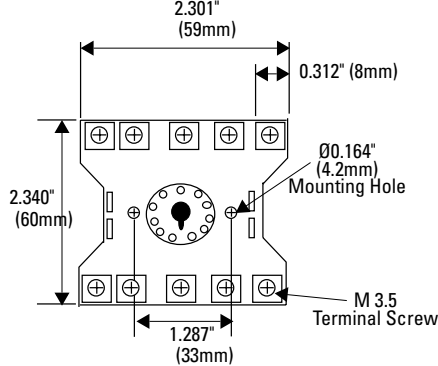

SR3B-05 Socket

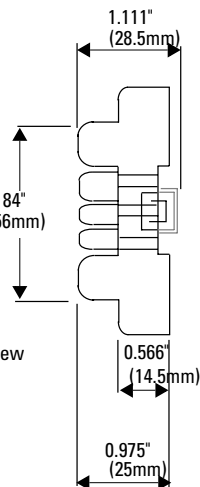
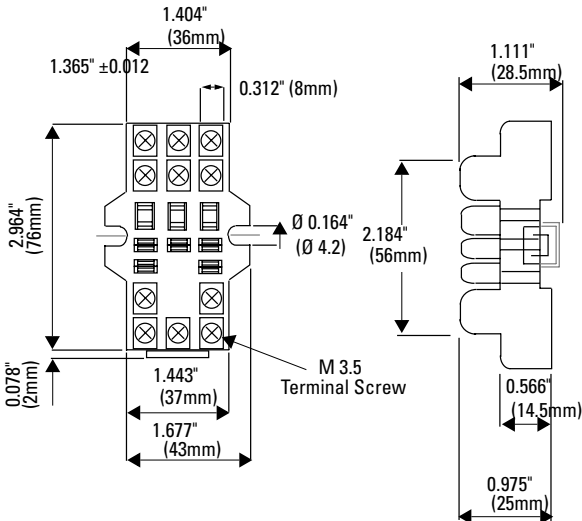

BNDN1000 DIN Rail

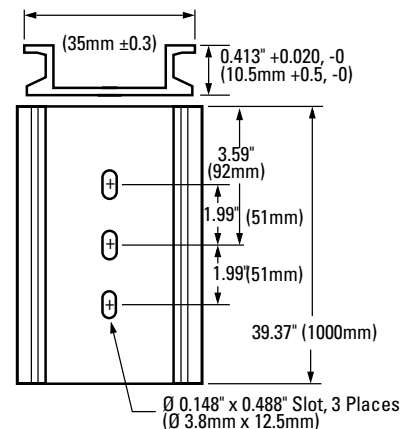

G