

# Preventa™ XPS Safety Relays Overview

## Safety

Good equipment is **safe** equipment, which combines:

- **Safety:** of personnel (equipment that does not pose a hazard),
- **Reliable Operation:** of production machinery (equipment in working order at all times).

## Safety is achieved by:

- Simultaneously optimizing safety and reliability,
- Applying fundamental principles: redundancy, and self-testing,
- Making reliability a design consideration (failure potential determining the design of the machine in a specified position, pro-active safety features),
- Ease of maintenance.

## Safety and Automation

All hazardous areas must be identified and their access restricted and controlled, that is to say that no failure or tampering should render the automated equipment hazardous to personnel.

Please note that the use of safety products does not necessarily assure the equipment is compliant with the European Machinery Safety Directive, OSHA, ANSI, or other USA safety requirements.

Rather, proper use, wiring, connections and planning contribute to the safety of the equipment as a whole.

**Safety systems are comprised of many components. No one safety component will ensure the safety of the system. The design of the complete safety system should be considered before you begin. It is very important to follow applicable safety standards when installing and wiring these components.**

## General Model of an Automated Machine

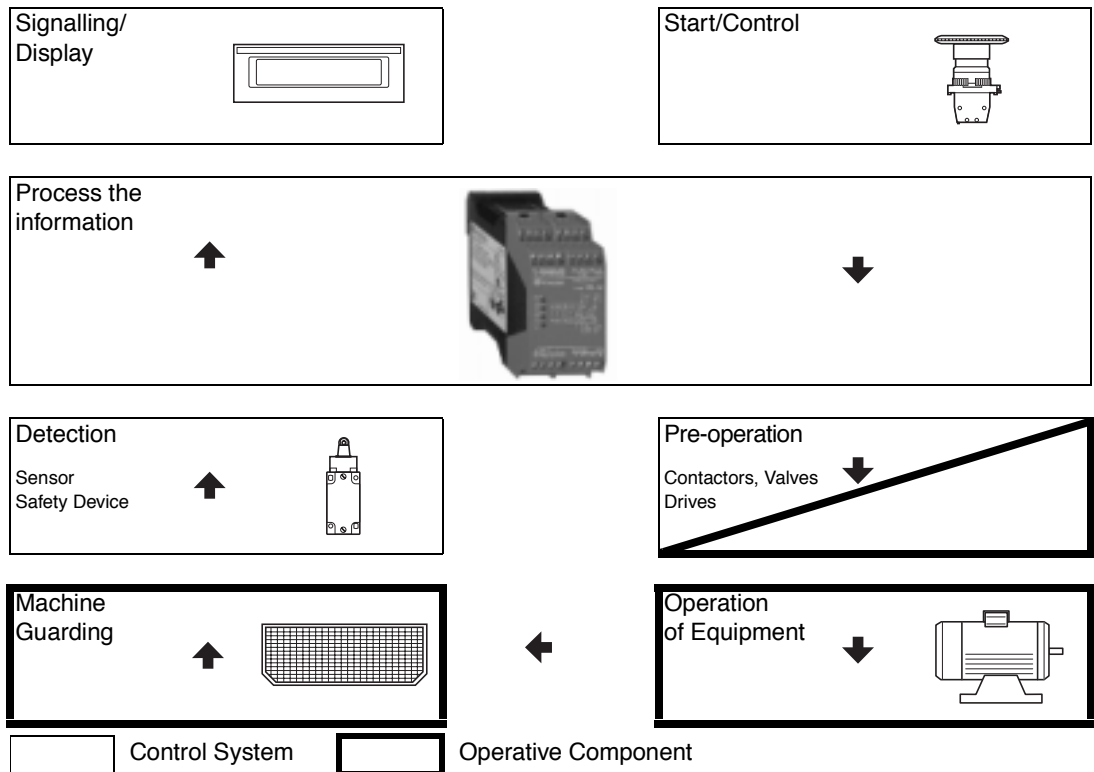

## Objective

- Open outputs upon occurrence of the first fault.
- Provide non-hazardous positioning (machine stops in a safe state).
- Enhance the safety of personnel operating industrial machinery.

## Basic Principles

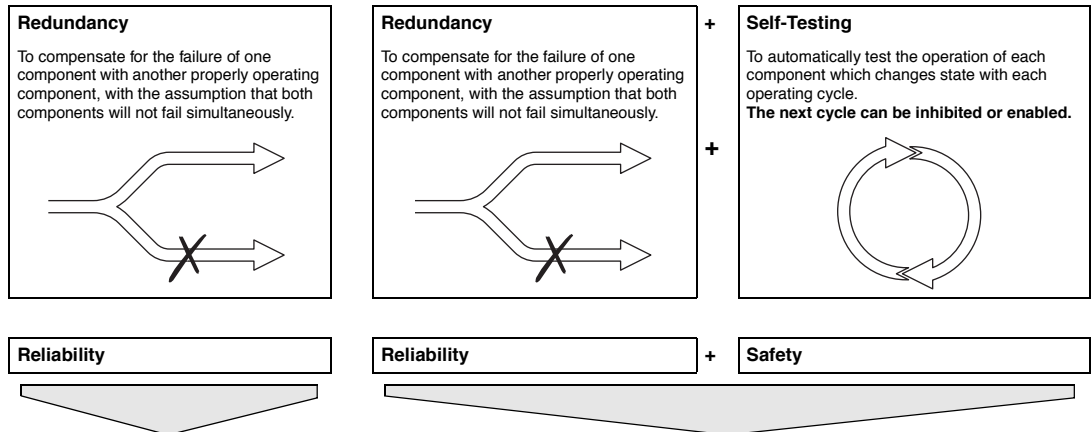

If an initial fault is not detected, there is no corrective action, allowing a second fault to occur, thereby compromising safety.

An initial fault in a safety circuit will be detected before a second fault can occur (next cycle inhibited).

The use of a Preventa™ XPS safety relay module allows a Category 4 control system to be designed in compliance with standard EN 954-1 (for safety-related control system components).

## Definitions

### Redundancy

This function is achieved by integrating dual circuitry into the design, combined with a test function which authorizes a control action only when at least two output signals are identical.

### Self-Test Function

Preventa™ safety relay modules use mechanically-linked N.O. and N.C. contact relays.

These relays ensure the uniform operation of their additional N.C. and N.O. contacts.

The reliability of the self-test function is ensured by verifying the proper operation of the contact relays during the current cycle.

To detect the failure of a mechanically-linked N.O. relay contact requires that the proper operation of its N.C. contacts be tested at the time of their integration into a self-test circuit. This detection is made possible only by using mechanically-linked contact relays.

# Preventa™ XPS Safety Relays Interposing Relay Concepts

## Effect on the Control Circuit without Interposing Relays/Contactors

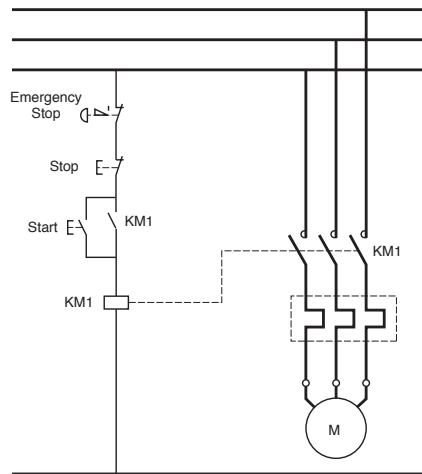

The control signal issued by the protective device (emergency stop circuit illustrated to the left) acts directly on the power contactor of the machine.

In this diagram, the possible fault conditions are:

- emergency stop button being shorted or jumpered.
- KM1 contactor sticking or welded.

When the emergency stop is operated, the signal is not recognized, and another sequence can begin following the emergency stop, despite the presence of the fault condition.

**In this case of failure, the safety function<sup>▲</sup> is compromised.** Therefore, reliable interposing relays/contactors must be used.

▲ A safety function is a function whose non-execution or untimely execution results in the immediate placement of the equipment into a non-hazardous condition.

## Effect on the Control Circuit with Interposing Relays/Contactors

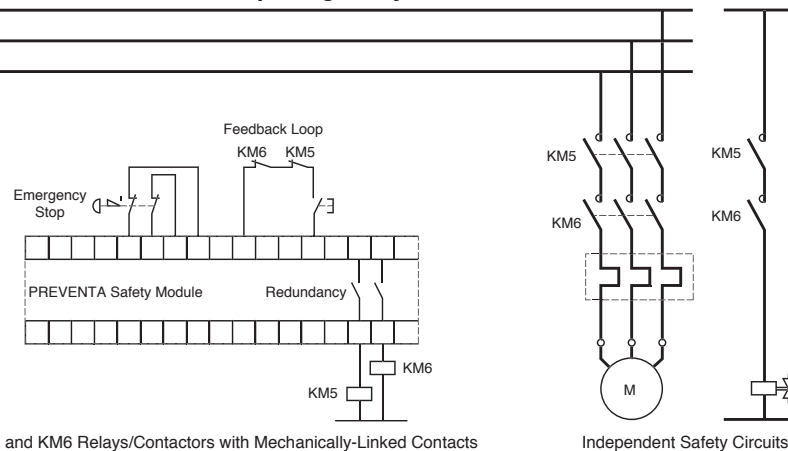

KM5 and KM6 Relays/Contactors with Mechanically-Linked Contacts

Independent Safety Circuits

Preventa™ safety relay modules provide **reliable** interposing relaying by eliminating the risks of a:

- control circuit fault (inputs),
- power circuit fault (outputs),
- safety module internal component fault.

**The safety function remains operative in all occurrences of one of these faults.**

### Relays and Contactors in the Safety Circuit

Use relays or contactors with mechanically-linked contacts on the safety outputs of the safety relay such as the Square D or Telemecanique products found in Appendix B, pages 303-306, of this catalog.

### Category Requirements

To meet the requirements of Category 3 per EN 954-1 (this standard deals with safety related parts of control systems), the output devices must be redundant - meaning there must be two relays/contactors in series controlling the load which can cause a hazardous movement. Using only one relay/contactors will reduce the control system to a **maximum Category 2**.

To meet the requirements of Category 4 per EN 954-1, the requirements for Category 3 need to be met, **plus** one of the N.C. auxiliary contacts from **each** of the two relays/contactors in series must be wired in series in the feedback loop. Without both of these N.C. contacts wired in series in the feedback loop, the control system is reduced to a **maximum Category 3**.

# Preventa™ XPS Safety Relays

## Safety Solutions: Applications for Protection Systems and Gates or Guards

### Selection Criteria

#### Low Potential of Hazard to Personnel

Locking or interlocking device based on the principle of intrinsically safe design (proven components and principles)

#### Quick-Stop Machinery. Locking (stop time < access time) \*

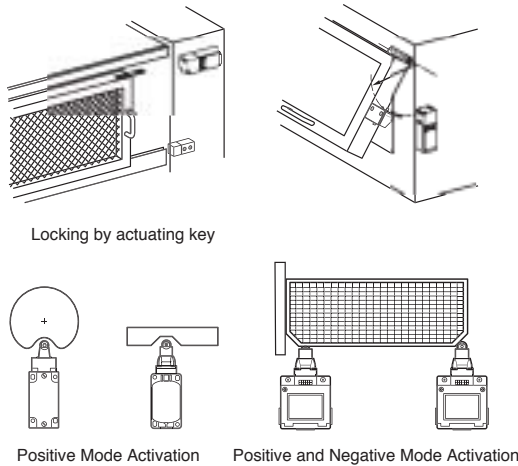

#### High Potential of Hazard to Personnel

Locking or interlocking device based on redundancy and self-testing. The safety relay modules provide these functions.

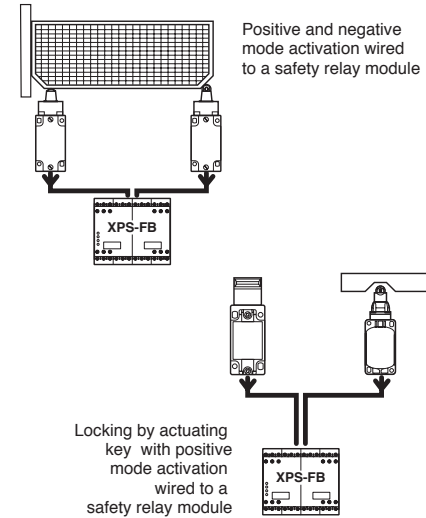

#### Inertia-Based Machinery; Long Stopping Times. Interlocking (stop time > access time)\*

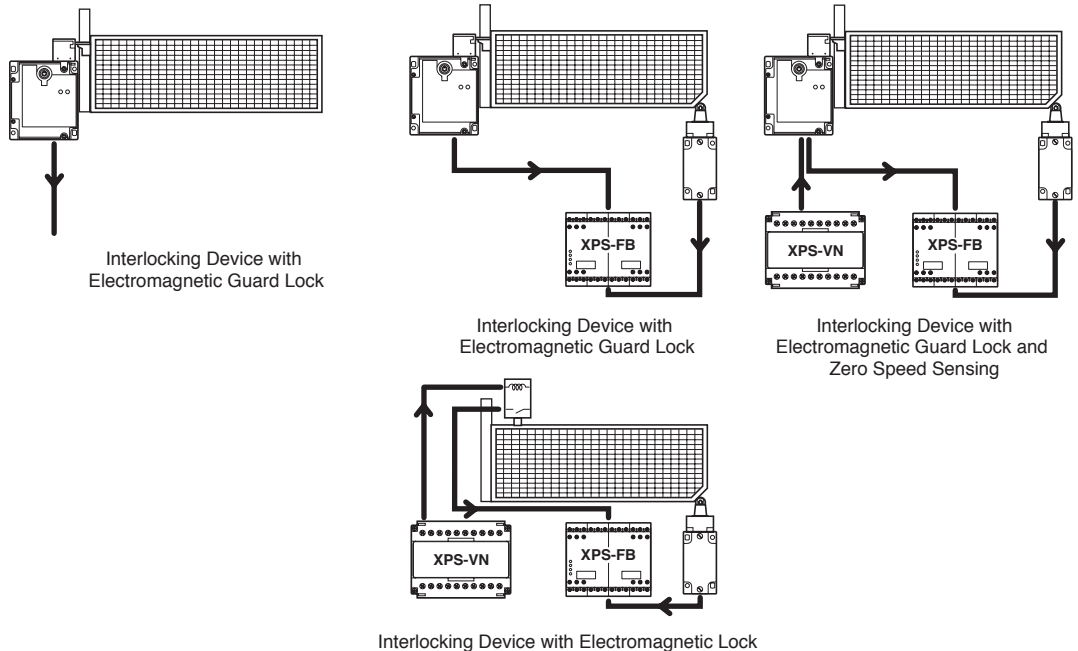

\* Stop time: time elapsed between issuance of the machine stop command and the moment at which the machine stops (risk elimination). Access time: time required for a person to access the hazardous area (calculated using an approach speed as the basis).

# Preventa™ XPS Safety Relays General Rating Curves

## Lifetime Curve and Switching Capability with N.O. Contacts

Determined by EN 60947-5-1 Table C2

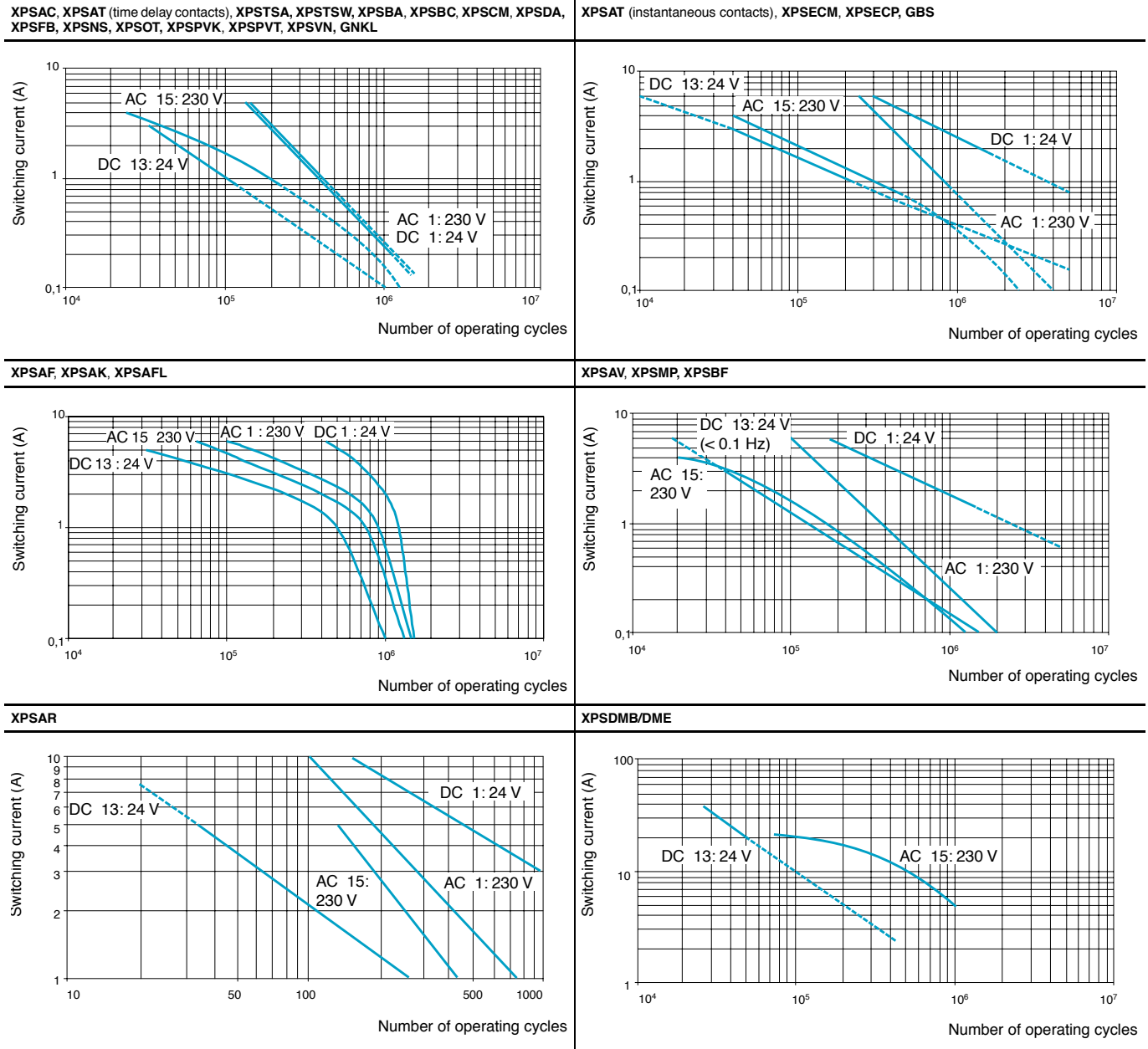

The product life expressed above is based on average usage and normal operating conditions. Actual operating life will vary with conditions. The above statements are not intended to nor shall they create any express or implied warranties as to product operation or life. For information on the limited warranty offered on this product please refer to the Square D terms and conditions of sale found in the Square D Digest.



# Preventa™ XPS Safety Relays

## Safety Contact Expansion

### Operating Principle

XPSEC safety contact expansion modules are available as attachments for Preventa™ XPS basic modules (for emergency stop, limit switch, two-hand control functions).

They are used to increase the number of basic module safety output contacts.

### Technical Data

Module Type		XPSECM	XPSECP
<b>Power Supply</b>			
Voltage	<b>V</b>	24 Vac/dc, 115/230 Vac	
Voltage limits		- 20...+10 % (24 Vac), + 20 % (24 Vdc) - 15...+15 % (115 Vac) - 15...+10 % (230 Vac)	
Frequency	<b>Hz</b>	50/60	
<b>Power Consumption</b>			
24 V	<b>VA</b>	< 5	
115 V/230 V	<b>VA</b>	< 6	
<b>Module Fuse Protection</b>		≤ 4 A external fuse for 24 V versions, internal electronic for 115 V and 230 V versions	
<b>Outputs</b>			
Voltage reference		Relay hard contacts	
No. and nature of safety circuits		4 N.O. (13-14, 23-24, 33-34, 43-44)	8 N.O. (13-14, 23-24, 33-34, 43-44, 53-54, 63-64, 73-74, 83-84)
No. and nature of additional circuits		1 N.C. (41-42) + 1 static	1 N.C. (91-92) + 1 static
AC-15 Breaking capacity	<b>VA</b>	B300: inrush 3600, sealed 360	
DC-13 Breaking capacity		24 V/1.5 A - L/R = 50 ms	
Static output breaking capacity		24 V/20 mA, 48 V/10 mA	
Max thermal current (Ithe)	<b>A</b>	5	
Maximum thermal current sum	<b>A</b>	24	30
Output fuse protection per IEC 60947-5-1, VDE 0660 Part 200	<b>A</b>	6 A fuse	
Minimum current	<b>mA</b>	10	
Minimum voltage	<b>V</b>	17	
<b>Electrical Life</b>		See page 156	
<b>Response Time from Input Breaking</b>	<b>ms</b>	< 20	
<b>Rated Insulation Voltage (Ui)</b>	<b>V</b>	300 (Pollution degree 2 per IEC 60947-5-1, DIN VDE 0110 Parts 1 and 2)	
<b>Rated Impulse Withstand Voltage (Uimp)</b>	<b>kV</b>	4 (Overvoltage category III, per IEC 60947-1, DIN VDE 0110 Parts 1 and 2)	
<b>LED Display</b>		3	
<b>Operating Temperature</b>		+ 14 °F to + 130 °F (- 10 °C to + 55 °C)	
<b>Storage Temperature</b>		- 13 °F to + 185 °F (- 25 °C to + 85 °C)	
<b>Degree of Protection per IEC 60529</b>			
Terminals		IP 20	
Housing		IP 40	
<b>Connection</b>			
Type		Captive screw-clamp terminals. Maximum wire size: 1-12 AWG (1 x 4 mm <sup>2</sup> ) without cable end, 2-14 AWG (2 x 2.5 mm <sup>2</sup> ) with cable end	
<b>Recommended Terminal Clamp Torque</b>		7.0 in.lbs. (0.8 Nm)	

## Preventa™ XPS Safety Relays Safety Contact Expansion

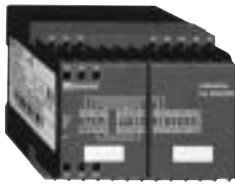

XPSECM



XPSECP

### Ordering Information

Description	No. of Safety Circuits	Power Supply	Catalog Number	Weight oz. (kg)
Safety modules for expanding the number of safety contacts	4	24 Vac/dc	XPSECM5131	19 (0.550)
		115 Vac	XPSECM3431	23 (0.650)
		230 Vac	XPSECM3731	23 (0.650)
	8	24 Vac/dc	XPSECP5131	19 (0.550)
		115 Vac	XPSECP3431	23 (0.650)
		230 Vac	XPSECP3731	23 (0.650)

Suitable for use in circuits through Category 4 per EN 954-1.

See page 258 for dimensions.

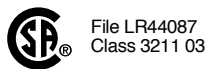

# Preventa™ XPS Safety Relays Safety Contact Expansion

## Wiring Diagrams and Connections

### XPSECM Connection Diagram

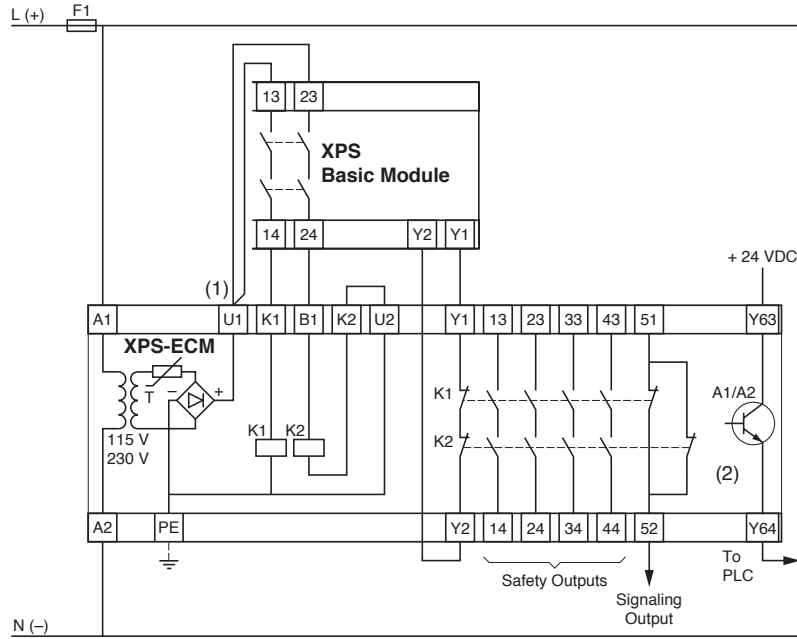

- (1) When installing basic modules and contact expansion modules into different electrical enclosures, use different individual wires between terminals U1-13 and U1-23.
- (2) Operating status of internal electronic fuse (Y63-Y64).

### Functional Diagram of the XPSECM Module

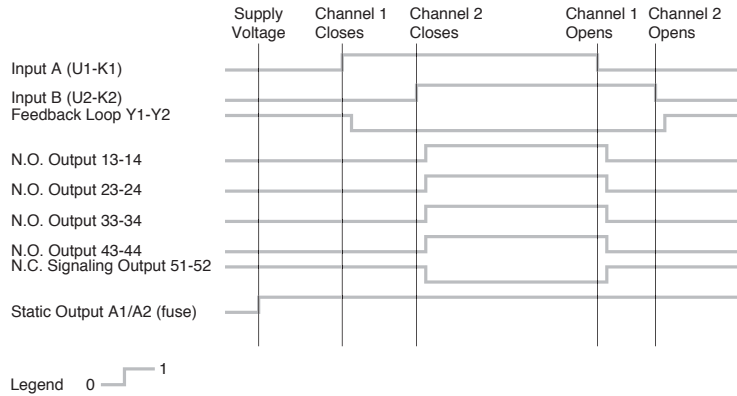

Wiring Diagrams and Connections

XPSECP  
Connection Diagram

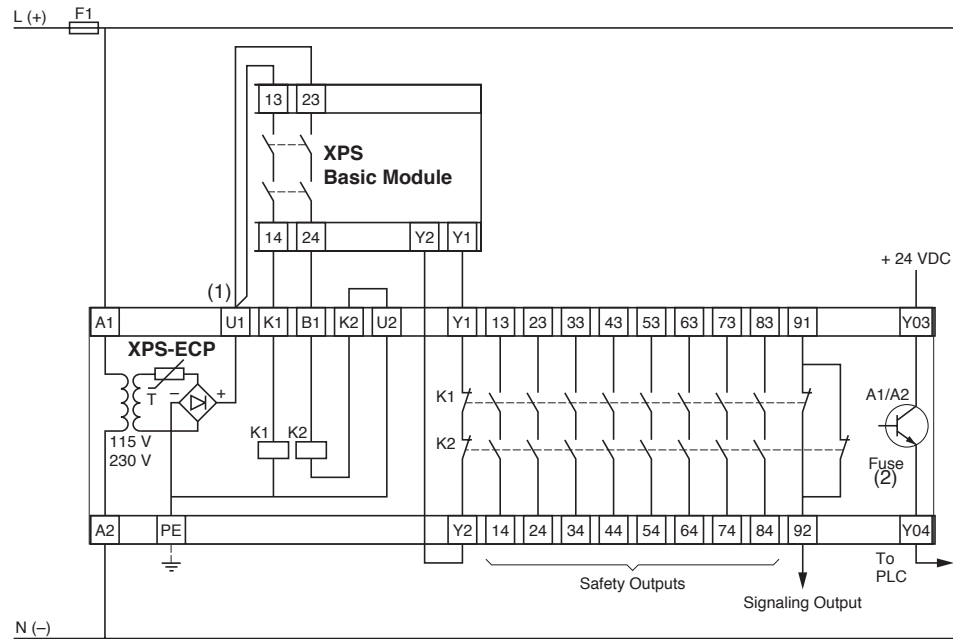

- (1) When installing basic modules and contact expansion modules into different electrical enclosures, use different individual wires between terminals U1-13 and U1-23.
- (2) Operating status of internal electronic fuse (Y03-Y04).

Functional Diagram of the XPSECP Module

Functional Diagram of the XPS-ECP Module

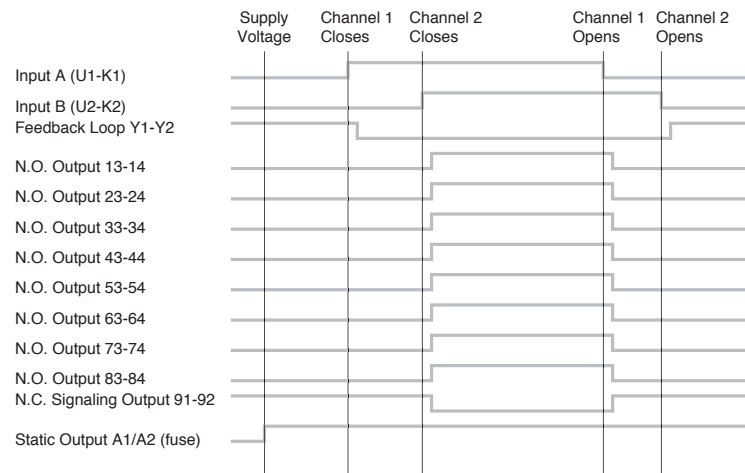

Legend 0 1