

		Overview	8/2
80 A		Instantaneous Trip Circuit Breakers, NZMH 4-...-OBI-CNA Motor Disconnect Switches, NZMH 4-...-CNA Accessories	8/4 8/5 8/6
125 A		Inverse time Circuit Breakers, NZM(H) 6(B)-.../ZM6A-...NA Instantaneous Trip Circuit Breakers, NZM(H) 6(B)- OBI-CNA Motor Disconnect Switches, NZM(H) 6(B)-.../ZM6-...-CNA Motor Disconnect Switches, N 6-...-CNA Accessories	8/12 8/13 8/14 8/15 8/16
250 A		Inverse time Circuit Breakers, NZM(H) 9-.../ZM9A-...NA Instantaneous Trip Circuit Breakers, NZM(H) 9-...-OBI-CNA Motor Disconnect Switches, NZM(H) 9-.../ZM9-...-CNA Motor Disconnect Switches, N 9-...-CNA Accessories	8/22 8/23 8/24 8/25 8/26
1000 A		Inverse time Circuit Breakers, NZM 12-.../ZM12(A)(V)-...NA Motor Disconnect Switches, N 12-...-CNA Accessories	8/32 8/33 8/34
150 A		Overview NZM 7.....-NA Inverse time Circuit Breakers, NZM 7(A)-...S-NA(-M8) Molded Case Switches, NZM 7-...-NA(-M8) Accessories	8/40 8/44 8/45 8/46
600 A		Overview NZM 10.....-NA Inverse time Circuit Breakers, NZM 10-...(N)(S)(H)-NA Instantaneous Trip Circuit Breakers, NZM 10-...OBI-CNA Molded Case Switches, NZM 10-...-N/B-NA Components for NZM 10...-NA Circuit Breakers Accessories	8/54 8/58 8/60 8/61 8/62 8/64
		Trip Curves Technical Data	8/72 8/77
		Dimensions	8/84

1	2	3	4	5
Inverse Time Circuit Breakers		Frame Rating	UL/ CSA Interrupting Ratings kA RMS SYM @	
	Amps	240 VAC	480 VAC	600 VAC
Thermal-Magnetic Trip UL 489/CSA 22.2 No. 5.1; IEC/EN 60 947-2				
	NZM 6B-.../ZM 6A-...-NA	15 - 125	25	14
	NZMH 6-.../ZM6A-...-NA Fuseless Current Limiting	15 - 125	100	25
	NZM 7A-...N-NA¹⁾	25 - 150	65	—
	NZM 9-.../ZM 9A-...-NA	70 - 250	30	18
	NZMH 9-.../ZM9A-...-NA Fuseless Current Limiting	70 - 250	200	42
Solid State Trip UL 489/CSA 22.2 No. 5.1; IEC/EN 60 947-2				
	NZM 10-...N/ZM 10(A)-...-NA	200 - 600	65	35
	NZM 10-...S/ZM 10(A)-...-NA	200 - 600	100	42
	NZM 10-...H/ZM 10(A)-...-NA Fuseless Current Limiting	200 - 600	200	50
	With trip delay feature for selectivity in networks			
	NZM 10-...N/ZM 10V(A)-...-NA	200 - 600	65	35
	NZM 10-...S/ZM 10V(A)-...-NA	200 - 600	100	42
	NZM 12-.../ZM 12(A)-...-NA²⁾	300 - 1000	65	50
	With trip delay feature for selectivity in networks			
	NZM 12-.../ZM 12V-...-NA²⁾	300 - 1000	65	50

1) Type NZM 7... currently UL/CSA only. IEC 60 947-2 Conformity in preparation.

2) Type NZM 12... UL/CSA only.

All Inverse time Circuit Breakers are UL Listed and CSA Certified, in compliance with IEC/EN 60 947-2 (Circuit Breakers) and CE Marked. Consult the technical data at the back of this section and Moeller Electric for IEC/EN ratings.

Disconnect Switches, Molded Case Switches
Circuit Breakers



1	2	3	4	5
Instantaneous Trip Circuit Breakers	Frame Rating	UL/ CSA Interrupting Ratings kA RMS SYM @		
	Amps	240 VAC	480 VAC	600 VAC
Instantaneous Trip Type Circuit Breakers UL 489/CSA 22.2 No. 5.1				
NZMH 4-...-OBI-CNA	2.1 - 18	UL Recognized and CSA Certified Instantaneous Trip circuit breakers no longer carry interrupting ratings as stand-alone devices. Per the intent of NEC Article 430-52, an instantaneous trip circuit breaker shall be used only if part of a listed combination motor controller. Short circuit ratings are, therefore, established and valid only for the listed combination motor controller assembly and associated housing or enclosure. Consult Section 3 of this catalog for Combination Motor Controller short circuit ratings as standard starters featuring Type NZM Instantaneous Trip Circuit Breakers. Consult Moeller Electric for Combination Motor Controller high fault short circuit ratings as Motor Control Center unit starters featuring Type NZM Instantaneous Trip Circuit Breakers.		
NZMH 4-...-OBI-Form CDN	2.1 - 18			
NZM 6B-.../ZM 6-...-OBI-CNA	0.6 - 125			
NZMH 6-.../ZM 6-...-OBI-CNA	33 - 125			
NZM 9-.../ZM 9-...-OBI-CNA	63 - 250			
NZMH 9-.../ZM 9-...-OBI-CNA	63 - 250			
NZM 10-...N/ZM-...-OBI-NA	400 - 600			
NZM 10-...H/ZM-...-OBI-NA	400 - 600			
Motor Disconnect Switches UL 508/CSA 22.2 Nr. 14, IEC/EN 60 947-2, CE HP rated, with adjustable thermal and magnetic trips		UL / CSA Short Circuit Ratings		
NZMH 4-...-CNA ¹⁾	4 - 80	100	25	25
NZM 6B-.../ZM 6-...-CNA	15 - 125	25	25	14
NZMH 6-.../ZM 6-...-CNA	15 - 125	100	65	25
NZM 9-.../ZM 9-...-CNA	63 - 250	30	25	18
NZMH 9-.../ZM 9-...-CNA	63 - 250	200	85	42
Motor Disconnect Switches UL 508/CSA 22.2 Nr. 14, IEC/EN 60 947-3, CE HP rated, without trip elements				
N6-...-CNA	150	10	10	10
N9-...-CNA	250	10	10	10
N12-...-CNA ²⁾	1200	42	42	42
Molded Case Switches UL 1087, CSA 22.2 Nr. 5.2, IEC/EN 60 947-3, CE Without trip elements				
NZM 7-...-NA(-M8)	200	25	25	18
NZM 10-...N/B-NA	600	25	25	25



1) NZMH 4-...-CNA in the range 4 - 16 Amps, UL/CSA only.

2) N12-...-CNA, UL/CSA only.

Consult the technical data at the back of this section and Moeller Electric for IEC/EN ratings.

Molded Case Circuit Breakers - Instantaneous Trip Type NZMH 4-...-OBI...

UL/CSA

1	2	3	4	5
Frame Rating	Continuous Current Rating	Adjustable Magnetic Trip Range	Type	Price
	Amps	Amps		\$
Instantaneous Trip Circuit Breakers Up to 480 V AC, UL/CSA				
	2.1	6...12	NZMH 4-2, 1-12-OBI-CNA	See Price List
	3.7	11...20	NZMH 4-3, 7-20-OBI-CNA	See Price List
	6.6	18 ...32	NZMH 4-6, 6-32-OBI-CNA	See Price List
	10	28 ...50	NZMH 4-10, 50-OBI-CNA	See Price List
	12	42 ...80	NZMH 4-12, 80-OBI-CNA	See Price List
	15	64 ...120	NZMH 4-15, 120-OBI-CNA	See Price List
	18	100... 200	NZMH 4-18, 200-OBI-CNA	See Price List
Instantaneous Trip Circuit Breakers Up to 600Y/347 V AC, CSA Certified only				
	2.1	6...12	NZMH 4-2, 1-12-OBI-FORM CDN	See Price List
	3.7	11...20	NZMH 4-3, 7-20-OBI-FORM CDN	See Price List
	6.6	18 ...32	NZMH 4-6, 6-32-OBI-FORM CDN	See Price List
	10	28 ...50	NZMH 4-10, 50-OBI-FORM CDN	See Price List
	12	42 ...80	NZMH 4-12, 80-OBI-FORM CDN	See Price List
	15	64 ...120	NZMH 4-15, 120-OBI-FORM CDN	See Price List
	18	100... 200	NZMH 4-18, 200-OBI-FORM CDN	See Price List

Type **NZMH 4-...-OBI...** Molded Case Circuit Breakers are UL Recognized (UL 489) and CSA Certified (22.2 Nr. 5.1) Instantaneous Trip type Circuit Breakers with an adjustable magnetic trip function.

Per NEC, they provide motor short circuit protection as part of a listed combination motor controller that includes coordinated motor overload protection.

Short circuit interrupting ratings are, therefore, established and valid only for the listed combination motor controller assembly and associated housing or enclosure.

The **NZMH 4** instantaneous trip circuit breaker features a current limiting design contact assembly and can provide high fault short circuit current ratings of up to 100kA @ 480VAC.

Consult Section 3 of this catalog for Combination Motor Controller short circuit ratings as standard starters featuring Type **NZM** Instantaneous Trip Circuit Breakers.

Consult Moeller Electric for Combination Motor Controller high fault short circuit ratings as Motor Control Center unit starters featuring Type **NZMH** Instantaneous Trip Circuit Breakers.

Ordering Information:

State type from Column 4. Example: **NZMH 4-18-200-OBI-CNA**

Note:

- Operating Handle supplied separately. Consult page 8/8 for available handle types.
- Consult page 8/6-11 for additional accessories.
- Line and Load field-wiring terminals for cable connection supplied as standard.

1	2	3	4				5	6	
Frame Rating	Adjustable Thermal Range for motor overload protection	Adjustable Magnetic Trip Range	Motor rating				Type	Price	
	Amps	Amps	200 V HP	230 V HP	460 V HP	575 V HP		\$	
NZMH 4-...-CNA Motor Disconnect Switch									
 <p>NZMH 4-...-CNA (80 Amps)</p>	4 – 6	40 – 80	1 1/2	1 1/2	3	5	NZMH 4-6-CNA	See Price List	See Price List
	6 – 10	60 – 120	2	3	5	7 1/2	NZMH 4-10-CNA	See Price List	See Price List
	10 – 16	100 – 200	3	5	10	10	NZMH 4-16-CNA	See Price List	See Price List
	16 – 25	160 – 320	5	7 1/2	15	20	NZMH 4-25-CNA	See Price List	See Price List
	25 – 40	260 – 500	10	10	30	40	NZMH 4-40-CNA	See Price List	See Price List
	40 – 63	400 – 800	20	20	40	60	NZMH 4-63-CNA	See Price List	See Price List
	63 – 80	600 – 1000	25	30	60	75	NZMH 4-80-CNA	See Price List	See Price List

Type **NZMH 4-...-CNA** Disconnect Switches are UL recognized (UL 508) and CSA certified (22.2 Nr. 14) as 3 pole, HP rated manual motor disconnects with built-in thermal trips for motor overload protection. An adjustable dial on the front of the switch (refer to column 2) can be set to the Motor Full Load Current.

They also feature an adjustable magnetic trip to provide additional protection in case of short circuits. In addition they are suitable for group applications per the intent of NEC 430-53 and CEC part 1, Rule 28-206.

NEC/CEC Group Application ratings:

Maximum Group Fuse or Circuit Breaker			UL/CSA Short Circuit Current Rating RMS Sym Rating @		
Listed Branch Circuit Protective Fuse	Listed Branch Circuit Protective Breaker		240VAC	480VAC	600VAC
Amps	Amps		100 kA	25 kA	25 kA
600	600				

Types **NZMH 4-25-CNA**, **NZMH 4-40-CNA**, **NZMH 4-63-CNA** and **NZMH 4-80-CNA** Disconnect Switches are CE Marked and in Conformity with IEC/EN 60 947-2 (Circuit Breakers), which makes them suitable internationally as inverse time molded case circuit breakers with adjustable thermal and magnetic trips. Consult the technical data at the back of this section and Moeller Electric for IEC/EN ratings.

Ordering Information:

State type from Column 4. Example: **NZMH 4-25-CNA**

Note:

- Operating Handle supplied separately. Consult page 8/8 for available handle types.
- Consult page 8/6 - 11 for additional accessories.
- Line and Load field-wiring terminals for cable connection supplied as standard.

Molded Case Circuit Breakers and Disconnect Switches Auxiliary Contacts and Accessories for NZMH 4...

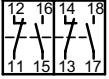
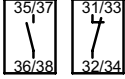
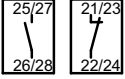
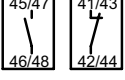
1	2	3	4	5
	Contacts	Type To be ordered with device only. Add below suffix.	Price \$	Notes
	N.O. N.C.			
Standard Auxiliary Contacts 	2 2	+NHI 22-NZM 4/6-NA	See Price List	Combination possibilities of auxiliary contacts: NHI VHI AHI RHI ● ● — — ● — ● — ● — — ●
Early-Make Auxiliary Contacts 	1 1	+VHI-NZMH 4-NA	See Price List	Dots in each row represent the types which can be combined together. Dashes indicate incompatibility. VHI, AHI and RHI are supplied as 1 N.O. and 1 N.C. contact set but can be field modified as 2 N.O. or 2 N.C. contacts.
Handle operated Early-Make Auxiliary Contacts 	1 1	+AHI-NZMH 4-NA	See Price List	
Trip Indicating Auxiliary Contacts 	1 1	+RHI-NZMH 4-NA	See Price List	

Type **NHI**... are standard auxiliary contacts. They operate simultaneously with the main contacts. They can be typically used for signalling or switching auxiliary circuits such as a control circuit.

Type **VHI**... are Early Make auxiliary contacts and lead the main contacts when switching ON as well as switching OFF. This makes them ideal for load shedding purposes or in conjunction with voltage trips in control circuits.

Type **AHI**... are handle operated Early Make auxiliary contacts. They operate in advance of the main contacts, shortly after the handle has left the OFF position. They can be typically used to convert the manual actuation of the switch into a control function for circuit interlocking purposes.

Type **RHI**... are trip indicating auxiliary contacts. They work independently of the normal ON and OFF operations of the device, switching only when the device has tripped due to overloads, overcurrents or other tripping functions such as voltage trips.

Refer to diagrams below for further details:

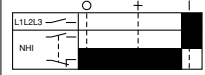
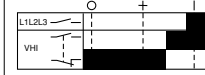
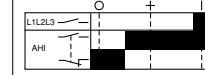
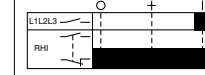
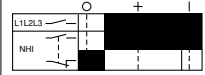
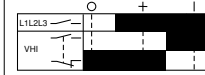
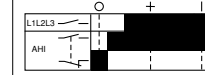
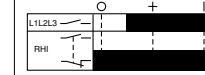
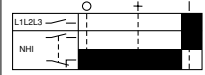
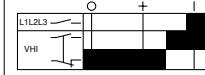
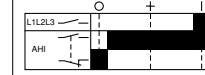
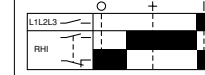
	NHI	VHI	AHI	RHI
Position of auxiliary contacts →	Same as main contacts	Same contact position in both OFF and Tripped position of the device.	Same contact position in both ON and Tripped position of the device.	Operates only when device is tripped (overload, short-circuit, shunt or undervoltage trips.)
Main Contacts: ■ Closed □ Open				
Switching ON ○ →				
Switching OFF ○ ←				
Tripped position + ←				



Ordering Information:

Auxiliary Contacts must be ordered with device. Add type from Column 3. Example: **+ VHI-NZMH 4-NA**.

Note:

Field mounting of contacts is allowed with use of kits. Consult Moeller Electric for information.





Molded Case Circuit Breakers and Disconnect Switches Voltage Trips for the NZMH 4...

1	2	3	4	5	6	
	Rated Control Voltage		Type	Price	Notes	
		V/Hz	To be ordered with device only. Add below suffix.	\$		
Shunt Trips						
Short-time duty rating						
	AC	120V 60Hz	+A-NZM 4/6 (120V 60Hz)	See Price List	Shunt Trips are typically used to electrically trip the device from a remote location. They are rated for short time duty only. Short time actuation can be achieved by using the NHI auxiliary contact ahead in series with the shunt trip coil. Shunt Trips cannot be mounted together with Undervoltage Trips.	
	AC	208V 60Hz	+A-NZM 4/6 (208V 60Hz)	See Price List		
	AC	240V 60Hz	+A-NZM 4/6 (240V 60Hz)	See Price List		
	AC	480V 60Hz	+A-NZM 4/6 (480V 60Hz)	See Price List		
	AC	600V 60Hz	+A-NZM 4/6 (600V 60Hz)	See Price List		
	DC	24V	+A-NZM 4/6 (24VDC)	See Price List		
Undervoltage Trips						
Non-delayed						
	AC	120V 60Hz	+U-NZM 4/6 (120V 60Hz)	See Price List		Undervoltage Trips will electrically trip the device open under power loss and can be used for control interlocking purposes e.g. to disconnect the main switch in Emergency-Stop circuits. They are rated for continuous duty. Power can be applied to the undervoltage trip using VHI early-make auxiliary contacts in series with the undervoltage trip coil. Undervoltage Trips cannot be mounted together with Shunt Trips.
	AC	208V 60Hz	+U-NZM 4/6 (208V 60Hz)	See Price List		
	AC	240V 60Hz	+U-NZM 4/6 (240V 60Hz)	See Price List		
	AC	480V 60Hz	+U-NZM 4/6 (480V 60Hz)	See Price List		
	AC	600V 60Hz	+U-NZM 4/6 (600V 60Hz)	See Price List		
	DC	24V	+U-NZM 4/6 (24VDC)	See Price List		

Ordering Information:

Voltage trips must be ordered with device. Add type from Column 4. Example: **+ U-NZM 4/6(480V, 60Hz)**.

Molded Case Circuit Breakers and Disconnect Switches Accessories for NZMH 4...

1	2	3	4	5	6
		Color of handle	Can be used with all devices of Type number	Type	Price
					\$
Handle for open or panel mounted devices					
Fastens to shaft, not padlockable					
		Gray	NZMH 4...	H 4U	See Price List
		Black	NZMH 4...	H 4U-SW	See Price List
Handle for Cover/Door Interlocking					
Degree of protection UL/NEMA 3R, 12; IEC IP 55					
Door coupling rotary handle. For front mounting in doors and covers. Can be locked in the OFF position with up to three padlocks (hasp thickness 6 – 8 mm). Door/cover interlocking supplied standard set in OFF position. Can be field modified for setting in ON position. 3 distinct Handle positions: OFF - + (tripped) - ON Red -Yellow version for Emergency-Stop function.					
		Gray	NZMH 4... NZM(H) 6(B)...	H 6-NA	See Price List
		Black	NZMH 4... NZM(H) 6(B)...	H 6-SW-NA	See Price List
		Red/ Yellow	NZMH 4... NZM(H) 6(B)...	RH 6-NA	See Price List
Extension shaft					
For mounting depths of 150...400 mm. Extends shaft length by 266 mm.					
			NZMH 4... NZM(H) 6(B)...	A-NZM 6	See Price List
Switch position indicator					
Indicates position of switch when panel door is open.					
			NZMH 4... NZM(H) 6(B)...	SA-NZM 6	See Price List
Mechanical Interlock					
For mechanical interlocking of two devices. Requires two handles, one for each switch. Order separately.					
			NZMH 4...	KV-2 NZM 4	See Price List



Ordering Information:
Specify Type from Column 5. Example: **H6-SW-NA**
If ordering with device, just add a "+" in front of the Type number. Example: **+ H6-SW-NA**

Disconnect Switches, Molded Case Switches

Circuit Breakers







Molded Case Circuit Breakers and Disconnect Switches Accessories for NZMH 4...

1	2	3	4	5	6
	Color of handle	Can be used with	Type To be ordered with device only. Add below suffix	Type	Price \$
Rear operation shafts For side panel mounting where device is only accessible from the rear (e.g. sides of enclosure panels). Must be combined with Type H...R rear operation handles. Factory installed only. Order with device.		NZMH 4...	+ R-NZMH 4	—	See Price List See Price List
Operating Handle for rear operation Used with rear operation shaft. Degree of protection: UL/NEMA 3R, 12; IEC IP 55 Can be locked in the OFF position with up to three padlocks (hasp thickness 6 – 8 mm). No cover/door interlocking provisions. 3 distinct Handle positions: OFF - + (tripped) - ON Red -Yellow version for Emergency-Stop function.		Gray NZMH 4 NZM(H) 6(B)	—	H 6-R-NA	See Price List See Price List
		Black NZMH 4 NZM(H) 6(B)	—	H 6-R-SW-NA	See Price List See Price List
		Red/ Yellow NZMH 4 NZM(H) 6(B)	—	RH 6-R-NA	See Price List See Price List
Legend Plate (for mounting with operating handle) Silver-colored, black lettering					
					
Specify desired text. Height of letters: 3.5, 5, and 7 mm		NZMH 4 NZM(H) 6(B)	—	ZSSOND-NZM 6	See Price List See Price List
Blank (for engraving or printing)		NZMH 4 NZM(H) 6(B)	—	ZS60-NZM 6	See Price List See Price List
Main Disconnect Warning plates. English Inscription: "Main Switch- Open only in OFF position" Silver-colored, black lettering		NZMH 4 NZM(H) 6(B)	—	ZS62-NZM 6	See Price List See Price List
Also available in other languages:			—	ZS...-NZM 6	See Price List See Price List
Afrikaans (81) Bulgarian (64) Czech (78) Danish (65) Dutch (67) Finnish (66) French (63) German (61) Greek (69) Hungarian (80) Italian (68) Norwegian (70) Polish (71) Portuguese (72) Romanian (73) Russian (74) Serbo-Croatian (76) Spanish (77) Swedish (75) Turkish (79)					
Insert key number into Type. Example: ZS 68-NZM 6 (Inscription in Italian language)					

Ordering Information:
 Specify Type from Column 5. Example: **H6-R-SW-NA**.
 If ordering with device, just add a "+" in front of the Type number. Example: **+ H6-R-SW-NA**

Note:
 Items in Column 4 are factory installed and must be ordered with the device.

Molded Case Circuit Breakers and Disconnect Switches Accessories for NZMH 4...

1	2	3	4
		Type	Price
			\$
<p>Main Disconnect Switch Assembly Kits for CE marked control panels per IEC/EN 60 204-1 Type NZMH 4... switches with dual UL/CSA and IEC/EN ratings are suitable for use as Main Disconnect switches in control panels that must be CE marked and designed to comply with the Machinery Directive standard EN 60 204-1. The kits shown below, ordered with the device or separately, will provide the necessary accessories to fulfill the Main Disconnect switch function for these applications. Note: In cases where the Main Disconnect switch also fulfills the Emergency-Stop function, please specify kits containing red handle and yellow backing plate assemblies.</p>			
<p>Kit includes: Main Disconnect handle with door/cover interlock for front mounting, red color handle with yellow backing plate for Emergency-Stop function, terminal cover and Main Switch marking plate.</p>		V-NZMH4	See Price List See Price List See Price List
<p>Kit includes: Main Disconnect handle for rear operated switches, red in color with yellow backing plate for Emergency-Stop function, supplied with a steel plate for panel side-mounting, terminal cover and Main Switch marking plate</p>		EA-NZM 4	See Price List See Price List See Price List
<p>Kit includes: Same as V-NZMH 4, except that the Main Disconnect handle is black in color with silver backing plate for standard, non-Emergency-Stop function.</p>		V-NZMH 4-SW	See Price List See Price List See Price List
<p>Kit includes: Same as EA-NZMH 4, except that the Main Disconnect handle is black in color with silver backing plate for standard, non-Emergency-Stop function.</p>		EA-NZM 4-SW	See Price List See Price List See Price List

Ordering Information:
 Specify Type from Column 3. Example: **V- NZMH 4**
 If ordering with device, just add a "+" in front of the Type number. Example: **+ V- NZMH 4**

Disconnect Switches, Molded Case Switches

Circuit Breakers





Molded Case Circuit Breakers and Disconnect Switches Accessories for NZMH 4...

1	2	3
	Type	Price \$
<p>Terminal Cover Provides shock hazard protection in the area of the field wiring power terminals. Can be used at top or bottom, one cover per side. Mandatory requirement on the supply side of Main Disconnect switches to provide protection against accidental contact with line side feed.</p>	H-NZMH 4	See Price List See Price List
<p>Clip For mounting NZMH 4... devices on a DIN rail. (Rail conforming to the standard EN 50 022).</p>	C-NZMH 4	See Price List See Price List

Ordering Information:
Specify Type from Column 3. Example: **V- NZMH 4**
If ordering with device, just add a "+" in front of the Type number. Example: **+ V- NZMH 4**



Molded Case Circuit Breakers- Instantaneous Trip type, 125 Amp NZM(H)6(B)-.../ZM6-...-OBI...

1	2	3	4	5
Frame Rating	Continuous Current Rating	Adjustable Magnetic Trip Range	Type	Price
	Amps	Amps		\$
Instantaneous Trip Circuit Breakers Up to 600 V AC, UL/CSA				
Standard Interrupting Ratings				
	33	100 - 200	NZM 6B-63/ZM 6-33-200-OBI-CNA	See Price List
	50	260 - 500	NZM 6B-63/ZM 6-50-500-OBI-CNA	See Price List
	60	400 - 800	NZM 6B-63/ZM 6-60-800-OBI-CNA	See Price List
	80	260 - 500	NZM 6B-100/ZM 6-80-500-OBI-CNA	See Price List
	100	600 - 1200	NZM 6B-100/ZM 6-100-1200-OBI-CNA	See Price List
	125	1000 - 2000	NZM 6B-160/ZM 6-125-2000-OBI-CNA	See Price List
NZM 6B-.../ZM6-...-OBI-CNA (125 Amps)				
High Fault Interrupting Ratings				
	33	100 - 200	NZMH 6-63/ZM 6-33-200-OBI-CNA	See Price List
	50	260 - 500	NZMH 6-63/ZM 6-50-500-OBI-CNA	See Price List
	60	400 - 800	NZMH 6-63/ZM 6-60-800-OBI-CNA	See Price List
	80	260 - 500	NZMH 6-100/ZM 6-80-500-OBI-CNA	See Price List
	100	600 - 1200	NZMH 6-100/ZM 6-100-1200-OBI-CNA	See Price List
	125	1000 - 2000	NZMH 6-160/ZM 6-125-2000-OBI-CNA	See Price List
NZMH6-.../ZM6-...-OBI-CNA (125 Amps)				

Type **NZM6B-.../ZM6-...-OBI...** and **NZMH6-.../ZM6-...-OBI...** Molded Case Circuit Breakers are UL Recognized (UL 489) and CSA Certified (22.2 Nr. 5.1) Instantaneous Trip type Circuit Breakers with an adjustable magnetic trip function. Per NEC, they provide motor short circuit protection as part of a listed combination motor controller that includes coordinated motor overload protection. Short circuit interrupting ratings are, therefore, established and valid only for the listed combination motor controller assembly and associated housing or enclosure.

The **NZMH6** instantaneous trip circuit breaker features a current limiting design contact assembly and can provide high fault short circuit current ratings of up to 65kA @ 480VAC.

Consult Section 3 of this catalog for Combination Motor Controller short circuit ratings as standard starters featuring Type **NZM** Instantaneous Trip Circuit Breakers.

Consult Moeller Electric for Combination Motor Controller high fault short circuit ratings as Motor Control Center unit starters featuring Type **NZMH** Instantaneous Trip Circuit Breakers.

Ordering Information:

State type from Column 4. Example: **NZM6B-63/ZM6-33-200-OBI-CNA**

Note:

- Operating Handle supplied separately. Consult page 8/18 for available handle types.
- Consult page 8/16 - 21 for additional accessories.
- Line and Load field-wiring terminals for cable connection supplied as standard.
- Consult Moeller Electric for Type **NZM(H)6(B)** Instantaneous Breakers with lower continuous current ratings.

1	2	3				4	5
Frame Rating	Continuous Current Rating	Maximum HP Rating 3 Phase @				Type	Price
	Amps	200 V HP	230 V HP	460 V HP	575 V HP		\$
Motor Disconnect Switches N6-...-CNA							
 (150 Amps)	63	20	25	50	60	N 6-63-CNA	See Price List
	100	30	40	75	100	N 6-100-CNA	See Price List
	150	40	60	100	125	N 6-160-CNA	See Price List

Type **N6...-CNA** Disconnect Switches are UL recognized (UL 508) and CSA certified (22.2 Nr. 14) as 3 pole, HP rated non-automatic manual motor disconnects without any overload or short circuit tripping elements. Their switching mechanism has 3 positions (OFF, ON, + "Tripped") and they can be equipped with voltage trip accessories such as shunt trip and undervoltage trip coils.
UL/CSA Short Circuit Rating @ 600VAC: 10 kA RMS Sym.

N6...-CNA Disconnect Switches are also CE Marked and in Conformity with IEC/EN 60 947-3 (Switch-Disconnectors), which makes them suitable internationally as Main Disconnect switches in a broad range of industrial applications. Consult the technical data at the back of this section and Moeller Electric for IEC/EN ratings.

Ordering Information:
State type from Column 5. Example: **N 6-100-CNA**

- Note:
- For direct-on-line switching of motors, use in combination with a listed magnetic contactor.
 - Operating Handle supplied separately. Consult page 8/18 for available handle types.
 - Consult page 8/16 – 21 for additional accessories.
 - Line and Load field-wiring terminals for cable connection supplied as standard.

Molded Case Circuit Breakers and Disconnect Switches Auxiliary Contacts for NZM(H)6(B)...

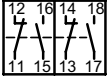
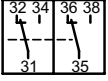
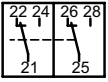
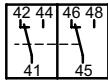
1	2	3	5	5																
Contacts	Type	Price	Notes																	
N.O. N.C.	To be ordered with device only. Add below suffix.	\$																		
Standard Auxiliary Contacts 	+NHI 22-NZM 4/6-NA	See Price List	Combination possibilities of auxiliary contacts:																	
Early-Make Auxiliary Contacts 	+VHI 002-NZM 6-NA	See Price List	<table border="0"> <tr> <td>NHI</td> <td>VHI</td> <td>AHI</td> <td>RHI</td> </tr> <tr> <td>●</td> <td>●</td> <td>—</td> <td>—</td> </tr> <tr> <td>●</td> <td>—</td> <td>●</td> <td>—</td> </tr> <tr> <td>●</td> <td>—</td> <td>—</td> <td>●</td> </tr> </table>	NHI	VHI	AHI	RHI	●	●	—	—	●	—	●	—	●	—	—	●	Dots in each row represent the types which can be combined together. Dashes indicate incompatibility.
NHI	VHI	AHI	RHI																	
●	●	—	—																	
●	—	●	—																	
●	—	—	●																	
Handle operated Early-Make Auxiliary Contacts 	+AHI 002-NZM 6-NA	See Price List																		
Trip Indicating Auxiliary Contacts 	+RHI 002-NZM 6-NA	See Price List																		

Type **NHI**... are standard auxiliary contacts. They operate simultaneously with the main contacts. They can be typically used for signalling or switching auxiliary circuits such as a control circuit.

Type **VHI**... are Early Make auxiliary contacts and lead the main contacts when switching ON as well as switching OFF. This makes them ideal for load shedding purposes or in conjunction with voltage trips in control circuits.

Type **AHI**... are handle operated Early Make auxiliary contacts. They operate in advance of the main contacts, shortly after the handle has left the OFF position. They can be typically used to convert the manual actuation of the switch into a control function for circuit interlocking purposes.

Type **RHI**... are trip indicating auxiliary contacts. They work independently of the normal ON and OFF operations of the device, switching only when the device has tripped due to overloads, overcurrents or other tripping functions such as voltage trips.

Refer to diagrams below for further details:



	NHI	VHI	AHI	RHI
Position of auxiliary contacts →	Same as main contacts	Same contact position in both OFF and Tripped position of the device.	Same contact position in both ON and Tripped position of the device.	Operates only when device is tripped (overload, short-circuit, shunt or undervoltage trips.)
Main Contacts: ■ Closed □ Open				
Switching ON ○ →				
Switching OFF ○ ←				
Tripped position + ←				

VHI and AHI-NZM 6 operate in similar fashion during switching ON and OFF.

Ordering Information:

Auxiliary Contacts must be ordered with device. Add type from Column 3. Example: + VHI 002-NZM 6-NA.







Molded Case Circuit Breakers and Disconnect Switches Voltage Trips for NZM(H)6(B)...

1	2	3	4	5	6
	Rated Control Voltage		Type	Price	Notes
	V/Hz		To be ordered with device only. Add below suffix.	\$	
Shunt Trips					
Short-time duty rating					
	AC	120V 60Hz	+A-NZM 4/6 (120V 60Hz)	See Price List	Shunt Trips are typically used to electrically trip the device from a remote location. They are rated for short time duty only. Short time actuation can be achieved by using the NHI auxiliary contact ahead in series with the shunt trip coil. Shunt Trips cannot be mounted together with Undervoltage Trips.
	AC	208V 60Hz	+A-NZM 4/6 (208V 60Hz)	See Price List	
	AC	240V 60Hz	+A-NZM 4/6 (240V 60Hz)	See Price List	
	AC	480V 60Hz	+A-NZM 4/6 (480V 60Hz)	See Price List	
	AC	600V 60Hz	+A-NZM 4/6 (600V 60Hz)	See Price List	
	DC	24V	+A-NZM 4/6 (24VDC)	See Price List	
Undervoltage Trips					
Continuous duty rating					
	AC	120V 60Hz	+U-NZM 4/6 (120V 60Hz)	See Price List	Undervoltage Trips will electrically trip the device open under power loss and can be used for control interlocking purposes e.g. to disconnect the main switch in Emergency-Stop circuits. They are rated for continuous duty. Power can be applied to the undervoltage trip using VHI early-make auxiliary contacts in series with the undervoltage trip coil. Undervoltage Trips cannot be mounted together with Shunt Trips.
	AC	208V 60Hz	+U-NZM 4/6 (208V 60Hz)	See Price List	
	AC	240V 60Hz	+U-NZM 4/6 (240V 60Hz)	See Price List	
	AC	480V 60Hz	+U-NZM 4/6 (480V 60Hz)	See Price List	
	AC	600V 60Hz	+U-NZM 4/6 (600V 60Hz)	See Price List	
	DC	24V	+U-NZM 4/6 (24VDC)	See Price List	

Ordering Information:

Voltage trips must be ordered with device. Add type from Column 4. Example: **+ U-NZM 4/6(480V, 60Hz)**.

Molded Case Circuit Breakers and Disconnect Switches Accessories for NZM(H)6(B)...

1	2	3	4	5	6
		Color of handle	Can be used with all devices of Type number	Type	Price
					\$
Handle for open or panel mounted devices					
Fastens to shaft, not padlockable					
		Gray	NZM(H)6(B) N6....	H 6U	See Price List
		Black	NZM(H)6(B) N6....	H 6U-SW	See Price List
Handle for Cover/Door Interlocking					
Degree of protection UL/NEMA 3R, 12; IEC IP 55					
Door coupling rotary handle. For front mounting in doors and covers. Can be locked in the OFF position with up to three padlocks (hasp thickness 6 – 8 mm). Door/cover interlocking supplied standard set in OFF position. Can be field modified for setting in ON position.					
3 distinct Handle positions: OFF - + (tripped) - ON					
Red -Yellow version for Emergency-Stop function.					
		Gray	NZMH 4 NZM(H) 6(B) N6....	H 6-NA	See Price List
		Black	NZMH 4 NZM(H) 6(B) N6....	H 6-SW-NA	See Price List
		Red/ Yellow	NZMH 4 NZM(H) 6(B) N6....	RH 6-NA	See Price List
Extension shaft					
For mounting depths of 150 – 400 mm. Extends shaft length by 266 mm. Only one extension shaft possible. Can also be used with the mechanical interlock.					
			NZMH 4 NZM(H) 6(B) N6....	A-NZM 6	See Price List
Padlocking accessory					
Enables the device to be padlocked OFF when the panel door is open. Accommodates up to 3 padlocks (hasp size 1/4", 6 – 8mm).					
A limit switch (Type AT0) can also be installed for signalling or electrical interlocking purposes.					
			NZM(H) 6(B) N6....	SVB-NZM 6	See Price List
Switch position indicator					
Indicates position of switch when panel door is open.					
			NZMH 4 NZM(H) 6(B) N6....	SA-NZM 6	See Price List
Maintenance Handle					
To actuate the device when the panel door is open.					
			NZM(H) 6(B) N6....	H6UZ	See Price List
Mechanical Interlock					
For mechanical interlocking of two devices. Requires two handles, one for each switch. Order separately.					
			NZM(H) 6(B) N6....	KV-2 NZM 6	See Price List

Ordering Information:
Specify Type from Column 5. Example: **H6-SW-NA**
If ordering with device, just add a "+" in front of the Type number. Example: **+ H6-SW-NA**

Molded Case Circuit Breakers and Disconnect Switches Accessories for NZM(H)6(B)...

1	2	3	4	5	6
	Color of handle	Can be used with	Type To be ordered with device only. Add below suffix	Type	Price \$
Rear operation shafts For side panel mounting where device is only accessible from the rear (e.g. sides of enclosure panels). Must be combined with Type H...R-NA rear operation handles. Factory installed only. Order with device.		NZM(H) 6(B)... N6...	+ R-NZMH 6	—	See Price List
Operating Handle for rear operation Used with rear operation shaft. Degree of protection: UL/NEMA 3R, 12; IEC IP 55 Can be locked in the OFF position with up to three padlocks (hasp thickness 6 – 8 mm). No cover/door interlocking provisions. 3 distinct Handle positions: OFF - + (tripped) - ON Red -Yellow version for Emergency-Stop function.		Gray NZMH 4 NZM(H) 6(B) N6... Black NZMH 4 NZM(H) 6(B) N6... Red/ Yellow NZMH 4 NZM(H) 6(B) N6...	—	H 6-R-NA H 6-R-SW-NA RH 6-R-NA	See Price List
Legend Plate (for mounting with operating handle) Silver-colored, black lettering					
 Specify desired text. Height of letters: 3.5, 5, and 7 mm		NZMH 4 NZM(H) 6(B) N6...	—	ZSSOND-NZM 6	See Price List
Blank (for engraving or printing)		NZMH 4 NZM(H) 6(B) N6...	—	ZS60-NZM 6	See Price List
Main Disconnect Warning plates. English Inscription: "Main Switch- Open only in OFF position" Silver-colored, black lettering		NZMH 4 NZM(H) 6(B) N6...	—	ZS62-NZM 6	See Price List
Also available in other languages:		NZMH 4 NZM(H) 6(B) N6...	—	ZS...-NZM 6	See Price List
Afrikaans (81) Bulgarian (64) Czech (78) Danish (65) Dutch (67) Finnish (66) French (63) German (61) Greek (69) Hungarian (80) Italian (68) Norwegian (70) Polish (71) Portuguese (72) Romanian (73) Russian (74) Serbo-Croatian (76) Spanish (77) Swedish (75) Turkish (79)					
Insert key number into Type. Example: ZS61-NZM 6 (Inscription in German language)					

Ordering Information:

Specify Type from Column 5. Example: **H6-R-SW-NA**.

If ordering with device, just add a "+" in front of the Type number. Example: **+ H6-R-SW-NA**

Note:

Items in Column 4 are factory installed and must be ordered with the device.



Molded Case Circuit Breakers and Disconnect Switches Accessories for NZM(H)6(B)...

1	2	3	4
	Type To be ordered with device only. Add suffix shown below	Type	Price \$
<p>Control Circuit Tap-Off Terminals Supplementary terminals attached to main terminals. 3 connections top and bottom. Factory addition only, must be ordered with device.</p> <p>Terminal Cover Provides shock hazard protection in the area of the field wiring power terminals. Can be used at top or bottom, one cover per side. Mandatory requirement on the supply side of Main Disconnect switches to provide protection against accidental contact with line side feed.</p>	<p>+ST-NA</p> <p>—</p>	<p>—</p> <p>H-NZM 6</p>	<p>See Price List See Price List See Price List See Price List</p> <p>See Price List See Price List See Price List See Price List</p>

Ordering Information:
 Accessory in Column 2 can only be ordered with device. Specify Type suffix. Example: **+ ST-NA**
 Specify Type from Column 3. Example: **H-NZM 6**
 If ordering with device, just add a “+” in front of the Type number. Example: **+ H-NZM 6**



Inverse Time Circuit Breakers, 250 Amps Thermal-Magnetic, Type NZM(H)9...-NA

UL/CSA, IEC/EN 60 947-2

1	2	3	4	5	6	7	
	Fixed Thermal Setting	Adjustable magnetic trip, supplied standard with the breaker	Adjustable magnetic trip, available as a substitute to standard ratings. Refer to ordering info below.	UL/CSA Interrupting ratings (AC, 60 Hz) RMS Sym Amps @		Type	Price
	Amps	Amps	Amps	240 V 480 V 600 V		Standard	\$

Standard Interrupting Rating NZM 9.../ZM 9A...-NA



(250A)

70	600 – 1200	400 – 800	30 kA 25 kA 18 kA	NZM 9-250/ZM 9A-70-NA	See Price List
80	600 – 1200	400 – 800		NZM 9-250/ZM 9A-80-NA	See Price List
90	600 – 1200	400 – 800		NZM 9-250/ZM 9A-90-NA	See Price List
100	1000 – 2000	600 – 1200 , 400 – 800		NZM 9-250/ZM 9A-100-NA	See Price List
125	1000 – 2000	600 – 1200 , 400 – 800		NZM 9-250/ZM 9A-125-NA	See Price List
150	1000 – 2000	600 – 1200		NZM 9-250/ZM 9A-150-NA	See Price List
175	1600 – 2400	600 – 1200 , 1000 – 2000		NZM 9-250/ZM 9A-175-NA	See Price List
200	1600 – 2400	600 – 1200 , 1000 – 2000		NZM 9-250/ZM 9A-200-NA	See Price List
225	1600 – 2400	600 – 1200 , 1000 – 2000		NZM 9-250/ZM 9A-225-NA	See Price List
250	1600 – 2400	600 – 1200 , 1000 – 2000		NZM 9-250/ZM 9A-250-NA	See Price List

High Interrupting Rating

NZMH9.../ZM 9A...-NA, UL/CSA Current-Limiting circuit breaker



(250A)

70	600 – 1200	400 – 800	200 kA 85 kA 42 kA	NZMH 9-250/ZM 9A-70-NA	See Price List
80	600 – 1200	400 – 800		NZMH 9-250/ZM 9A-80-NA	See Price List
90	600 – 1200	400 – 800		NZMH 9-250/ZM 9A-90-NA	See Price List
100	1000 – 2000	600 – 1200 , 400 – 800		NZMH 9-250/ZM 9A-100-NA	See Price List
125	1000 – 2000	600 – 1200 , 400 – 800		NZMH 9-250/ZM 9A-125-NA	See Price List
150	1000 – 2000	600 – 1200		NZMH 9-250/ZM 9A-150-NA	See Price List
175	1600 – 2400	600 – 1200 , 1000 – 2000		NZMH 9-250/ZM 9A-175-NA	See Price List
200	1600 – 2400	600 – 1200 , 1000 – 2000		NZMH 9-250/ZM 9A-200-NA	See Price List
225	1600 – 2400	600 – 1200 , 1000 – 2000		NZMH 9-250/ZM 9A-225-NA	See Price List
250	1600 – 2400	600 – 1200 , 1000 – 2000		NZMH 9-250/ZM 9A-250-NA	See Price List

Type **NZM 9.../ZM 9A...-NA** Molded Case Circuit Breakers are UL Listed (UL 489) and CSA Certified (22.2 Nr. 5.1) Inverse Time, thermal-magnetic Circuit Breakers with a fixed thermal and adjustable magnetic trip function.

Type **NZMH 9.../ZM 9A...-NA** Molded Case Circuit Breakers are UL Listed (UL 489) and CSA Certified (22.2 Nr. 5.1) Inverse Time, thermal-magnetic Current Limiting Circuit Breakers with a fixed thermal and adjustable magnetic trip function.

Both types are CE Marked and in Conformity with IEC/EN 60 947-2 (Circuit Breakers), which also makes them suitable internationally as inverse time molded case circuit breakers.

Consult the technical data at the back of this section and Moeller Electric for IEC/EN ratings.

Ordering Information:

State type from Column 6. Example: **NZM 9-250/ZM9A-250-NA** (Magnetic Trip range per Column 3).

Optional: Select a substitute magnetic trip range from column 4. Specify it in the Type number by including the number in bold.

Example: **NZM 9-250/ZM9A-250-2000-NA**

Note:



- Operating Handle supplied separately. Consult page 8/28 for available handle types.
- Consult page 8/26 - 31 for additional accessories.
- Line and Load field-wiring terminals for cable connection supplied as standard.

Disconnect Switches, Molded Case Switches

Circuit Breakers



Molded Case Circuit Breakers- Instantaneous Trip type, 250 Amp Type NZM(H)9-.../ZM9-...-OBI...

1	2	3	4	5
Frame Rating	Continuous Current Rating	Adjustable Magnetic Trip Range	Type	Price
	Amps	Amps		\$
Instantaneous Trip Circuit Breakers Up to 600 V AC, UL/CSA				
Standard Interrupting Ratings				
	63	400 – 800	NZM 9-250/ZM 9-63-800-OBI-CNA	See Price List
	100	600 – 1200	NZM 9-250/ZM 9-100-1200-OBI-CNA	See Price List
	160	1000 – 2000	NZM 9-250/ZM 9-160-2000-OBI-CNA	See Price List
	200	1600 – 2400	NZM 9-250/ZM 9-200-2400-OBI-CNA	See Price List
	250	1600 – 2400	NZM 9-250/ZM 9-250-2400-OBI-CNA	See Price List
NZM 9-.../ZM9-...-OBI-CNA (250 Amps)				
High Fault Interrupting Ratings				
	63	400 – 800	NZMH 9-250/ZM 9-63-800-OBI-CNA	See Price List
	100	600 – 1200	NZMH 9-250/ZM 9-100-1200-OBI-CNA	See Price List
	160	1000 – 2000	NZMH 9-250/ZM 9-160-2000-OBI-CNA	See Price List
	200	1600 – 2400	NZMH 9-250/ZM 9-200-2400-OBI-CNA	See Price List
	250	1600 – 2400	NZMH 9-250/ZM 9-250-2400-OBI-CNA	See Price List
NZMH 9-.../ZM9-...-OBI-CNA (250 Amps)				

Type **NZM9-.../ZM9-...-OBI...** and **NZMH9-.../ZM9-...-OBI...** Molded Case Circuit Breakers are UL Recognized (UL 489) and CSA Certified (22.2 Nr. 5.1) Instantaneous Trip type Circuit Breakers with an adjustable magnetic trip function.

Per NEC, they provide motor short circuit protection as part of a listed combination motor controller that includes coordinated motor overload protection. Short circuit interrupting ratings are, therefore, established and valid only for the listed combination motor controller assembly and associated housing or enclosure.

The **NZMH 9** instantaneous trip circuit breaker features a current limiting design contact assembly and can provide high fault short circuit current ratings of up to 85 kA @ 480 V AC.

Consult Section 3 of this catalog for Combination Motor Controller short circuit ratings as standard starters featuring Type **NZM...** Instantaneous Trip Circuit Breakers.

Consult Moeller Electric for Combination Motor Controller high fault short circuit ratings as Motor Control Center unit starters featuring Type **NZMH...** Instantaneous Trip Circuit Breakers.

Ordering Information:



State type from Column 4. Example: **NZM 9-250/ZM9-250-2400-OBI-CNA**

Note:

- Operating Handle supplied separately. Consult page 8/28 for available handle types.
- Consult page 8/ 26 - 31 for additional accessories.
- Line and Load field-wiring terminals for cable connection supplied as standard.

Motor Disconnect Switches Type NZM(H)9-.../ZM9-...-CNA

UL/CSA, IEC/EN 60 947-2

1	2	3	4				5	6
Frame Rating	Adjustable Thermal Range for motor overload protection	Adjustable Magnetic Trip Range	Maximum HP Rating 3 Phase @				Type	Price
	Amps	Amps	200 V HP	230 V HP	460 V HP	575 V HP	Standard	\$
Standard Short Circuit Ratings								
NZM 9-.../ZM 9-...-CNA								
	63 – 100	600 – 1200	30	30	75	100	NZM 9-250/ZM 9-100-CNA NZM 9-250/ZM 9-160-CNA NZM 9-250/ZM 9-200-CNA NZM 9-250/ZM 9-250-CNA	See Price List
	100 – 160	1000 – 2000	50	60	125	150		
	160 – 200	1600 – 2400	60	75	150	200		
	200 – 250	1600 – 2400	75	75	150	225		
	with optional lower magnetic trip values:							
(250A)	63 – 100	400 – 800	30	30	75	100	NZM 9-250/ZM 9-100-800-CNA NZM 9-250/ZM 9-160-1200-CNA NZM 9-250/ZM 9-200-2000-CNA NZM 9-250/ZM 9-250-2000-CNA	See Price List
	100 – 160	600 – 1200	50	60	125	150		
	160 – 200	1000 – 2000	60	75	150	200		
	200 – 250	1000 – 2000	75	75	150	225		
	High Fault Short Circuit Ratings							
NZMH 9-.../ZM 9-...-CNA								
	63 – 100	600 – 1200	30	30	75	100	NZMH 9-250/ZM 9-100-CNA NZMH 9-250/ZM 9-160-CNA NZMH 9-250/ZM 9-200-CNA NZMH 9-250/ZM 9-250-CNA	See Price List
	100 – 160	1000 – 2000	50	60	125	150		
	160 – 200	1600 – 2400	60	75	150	200		
	200 – 250	1600 – 2400	75	75	150	225		
	with optional lower magnetic trip values:							
(250A)	63 – 100	400 – 800	30	30	75	100	NZMH 9-250/ZM 9-100-800-CNA NZMH 9-250/ZM 9-160-1200-CNA NZMH 9-250/ZM 9-200-2000-CNA NZMH 9-250/ZM 9-250-2000-CNA	See Price List
	100 – 160	600 – 1200	50	60	125	150		
	160 – 200	1000 – 2000	60	75	150	200		
	200 – 250	1000 – 2000	75	75	150	225		

Types **NZM 9-.../ZM 9-...-CNA** and **NZMH 9-.../ZM 9-...-CNA** Disconnect Switches are UL recognized (UL 508) and CSA certified (22.2 Nr. 14) as 3-pole, HP rated manual motor disconnects with built-in thermal trips for motor overload protection. An adjustable dial on the front of the switch (refer to column 2) can be set to the Motor Full Load Current. They also feature an adjustable magnetic trip to provide additional protection in case of short circuits. Per NEC, Branch Circuit Overcurrent protection devices must be provided separately.

Type	UL/CSA Short Circuit Current Rating RMS Sym Rating @		
	240 V AC	480 V AC	600 V AC
NZM 9-.../ZM 9-...-CNA	30 kA	25 kA	18 kA
NZMH 9-.../ZM 9-...-CNA	200 kA	85 kA	42 kA

Types **NZM 9-.../ZM 9-...-CNA** and **NZMH 9-.../ZM 9-...-CNA** Disconnect Switches are CE Marked and in Conformity with IEC/EN 60 947-2 (Circuit Breakers), which makes them suitable internationally as inverse time molded case circuit breakers with adjustable thermal and magnetic trips. Consult the technical data at the back of this section and Moeller Electric for IEC/EN ratings.

Ordering Information:

State type from Column 5. Example: **NZM 9-250/ZM 9-200-CNA**

Note:

- For direct-on-line switching of motors, use in combination with a listed magnetic contactor.
- Operating Handle supplied separately. Consult page 8/28 for available handle types.
- Consult page 8/ 26 - 31 for additional accessories.
- Line and Load field-wiring terminals for cable connection supplied as standard.

1	2	3				4	5
Frame Rating	Continuous Current Rating	Maximum HP Rating 3 Phase @				Type	Price
	Amps	200 V HP	230 V HP	460 V HP	575 V HP		\$
N9-...-CNA Motor Disconnect Switches						N 9-250-CNA	See Price List See Price List
 (250A)	250	60	75	150	200		

Type **N9...-CNA** Disconnect Switches are UL recognized (UL 508) and CSA certified (22.2 Nr. 14) as 3 pole, HP rated nonautomatic manual motor disconnects without any overload or short circuit tripping elements. Their switching mechanism has 3 positions (OFF, ON, + "Tripped") and they can be equipped with voltage trip accessories such as shunt trip and undervoltage trip coils.
UL/CSA Short Circuit Rating @ 600 V AC: 10 kA RMS Sym.

N9...-CNA Disconnect Switches are also CE Marked and in Conformity with IEC/EN 60 947-3 (Switch-Disconnectors), which makes them suitable internationally as Main Disconnect switches in a broad range of industrial applications. Consult the technical data at the back of this section and Moeller Electric for IEC/EN ratings.

Ordering Information:
State type from Column 5: **N 9-250-CNA**

- Note:
- For direct-on-line switching of motors, use in combination with a listed magnetic contactor.
 - Operating Handle supplied separately. Consult page 8/28 for available handle types.
 - Consult page 8/ 26 - 31 for additional accessories.
 - Line and Load field-wiring terminals for cable connection supplied as standard.

Accessories for NZM(H) 9... Molded Case Circuit Breakers and Disconnect Switches Auxiliary Contacts

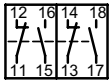
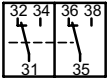
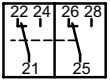
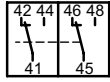
1	2	3	4	5																
	Contacts	Type To be ordered with device only. Add below suffix.	Price	Notes																
	N.O. N.C.		\$																	
Standard Auxiliary Contacts 	2 2	+NHI 22-NZM 9	See Price List	Combination possibilities of auxiliary contacts: <table style="margin-left: 20px;"> <tr> <td>NHI</td> <td>VHI</td> <td>AHI</td> <td>RHI</td> </tr> <tr> <td> </td> <td> </td> <td>—</td> <td>—</td> </tr> <tr> <td> </td> <td>—</td> <td> </td> <td>—</td> </tr> <tr> <td> </td> <td>—</td> <td>—</td> <td> </td> </tr> </table> Dots in each row represent the types which can be combined together. Dashes indicate incompatibility.	NHI	VHI	AHI	RHI			—	—		—		—		—	—	
NHI	VHI	AHI	RHI																	
		—	—																	
	—		—																	
	—	—																		
Early-Make Auxiliary Contacts 	2 Form C (Changeover) Contacts	+VHI 002-NZM 9	See Price List																	
Handle operated Early-Make Auxiliary Contacts 	2 Form C (Changeover) Contacts	+AHI 002-NZM 9	See Price List																	
Trip Indicating Auxiliary Contacts 	2 Form C (Changeover) Contacts	+RHI 002-NZM 9	See Price List																	







Type **NHI...** are standard auxiliary contacts. They operate simultaneously with the main contacts. They can be typically used for signalling or switching auxiliary circuits such as a control circuit.

Type **VHI...** are Early Make auxiliary contacts and lead the main contacts when switching ON as well as switching OFF. This makes them ideal for load shedding purposes or in conjunction with voltage trips in control circuits.

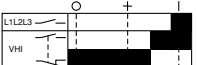
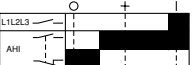
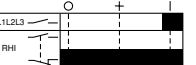
Type **AHI...** are handle operated Early Make auxiliary contacts. They operate in advance of the main contacts, shortly after the handle has left the OFF position. They can be typically used to convert the manual actuation of the switch into a control function for circuit interlocking purposes.

Type **RHI...** are trip indicating auxiliary contacts. They work independently of the normal ON and OFF operations of the device, switching only when the device has tripped due to overloads, overcurrents or other tripping functions such as voltage trips.

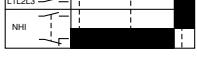
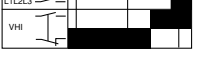

Refer to diagrams below for further details:

	NHI	VHI	AHI	RHI
Position of auxiliary contacts →	Same as main contacts	Same contact position in both OFF and Tripped position of the device.	Same contact position in both ON and Tripped position of the device.	Operates only when device is tripped (overload, short-circuit, shunt or undervoltage trips.)
Main Contacts: ■ Closed □ Open				
Switching ON ○ →				
Switching OFF ○ ←				
Tripped position + ←				

Ordering Information:
 Auxiliary Contacts must be ordered with device. Add type from Column 3.
 Example: **+ VHI 002-NZM 9**.









Molded Case Circuit Breakers and Disconnect Switches Voltage Trips for NZM(H) 9...

1	2	3	4	5	6
	Rated Control Voltage		Type To be ordered with device only. Add below suffix.	Price	Notes
		V/Hz		\$	
Shunt Trips 100% Continuous duty rating					
	AC	120 V 60 Hz	+A-NZM 9 (120V 60Hz)	See Price List	Shunt Trips are typically used to electrically trip the device from a remote location. The A-NZM 9... series is rated for 100% continuous duty. If desired, automatic disconnection of the shunt trip coil can be achieved by using the NHI auxiliary contact in series with the coil. Shunt Trips cannot be mounted together with Undervoltage Trips.
	AC	208 V 60 Hz	+A-NZM 9 (208V 60Hz)	See Price List	
	AC	240 V 60 Hz	+A-NZM 9 (240V 60Hz)	See Price List	
	AC	480 V 60 Hz	+A-NZM 9 (480V 60Hz)	See Price List	
	AC	600 V 60 Hz	+A-NZM 9 (600V 60 Hz)	See Price List	
	DC	24 V	+A-NZM 9 (24V DC)	See Price List	
Undervoltage Trips					
	AC	120 V 60 Hz	+U-NZM 9 (120V 60Hz)	See Price List	Undervoltage Trips will electrically trip the device open under power loss and can be used for control interlocking purposes e.g. to disconnect the main switch in Emergency-Stop circuits. They are rated for continuous duty. Power can be applied to the undervoltage trip using VHI early-make auxiliary contacts in series with the undervoltage trip coil. Undervoltage Trips cannot be mounted together with Shunt Trips.
	AC	208 V 60 Hz	+U-NZM 9 (208V 60Hz)	See Price List	
	AC	240 V 60 Hz	+U-NZM 9 (240V 60Hz)	See Price List	
	AC	480 V 60 Hz	+U-NZM 9 (480V 60Hz)	See Price List	
	AC	600 V 60 Hz	+U-NZM 9 (600V 60Hz)	See Price List	
	DC	24 V	+U-NZM 9 (24VDC)	See Price List	

Ordering Information:
Voltage trips must be ordered with device. Add type from Column 4. Example: **+ U-NZM 9 (480V, 60 Hz)**.



Molded Case Circuit Breakers and Disconnect Switches Accessories for NZM(H) 9...

1	2	3	4	5	6
		Color of handle	Can be used with all devices of Type number	Type	Price
					\$
Handle for open or panel mounted devices Fastens to shaft, not padlockable		Gray	NZM(H) 9... N 9...	H 9U	See Price List
		Black	NZM(H) 9... N 9...	H 9U-SW	See Price List
Handle for Cover/Door Interlocking Degree of protection UL/NEMA 3R, 12; IEC IP 55 Door coupling rotary handle. For front mounting in doors and covers. Can be locked in the OFF position with up to three padlocks (hasp thickness 6 – 8 mm). Door/cover interlocking supplied standard set in OFF position. Can be field modified for setting in ON position. 3 distinct Handle positions: OFF, + (tripped), ON Red -Yellow version for Emergency-Stop function.		Gray	NZM(H) 9... N 9...	H 9-NA	See Price List
		Black	NZM(H) 9... N 9...	H 9-SW-NA	See Price List
		Red/ Yellow	NZM(H) 9... N 9...	RH 9-NA	See Price List
Extension shaft For mounting depths of 190...400 mm. Extends shaft length by 223 mm. Only one extension shaft possible. Can also be used with the mechanical interlock.			NZM(H) 9... N 9...	A-NZM 9	See Price List
Padlocking accessory Enables the device to be padlocked OFF when the panel door is open. Accommodates up to 3 padlocks (hasp size 1/4", 6 – 8mm). A limit switch (Type AT0) can also be installed for signalling or electrical interlocking purposes.			NZM(H) 9... N 9...	SVB-NZM 9	See Price List
Switch position indicator Indicates position of switch when panel door is open.			NZM(H) 9... N 9...	SA-NZM 9	See Price List
Maintenance Handle To actuate the device when the panel door is open.			NZM(H) 9... N 9...	H9UZ	See Price List
Mechanical Interlock For mechanical interlocking of two devices. Requires two handles, one for each switch. Order separately.			NZM(H) 9... N 9...	KV-2 NZM 9	See Price List

Ordering Information:
 Specify Type from Column 5. Example: **H9-SW-NA**
 If ordering with device, just add a "+" in front of the Type number. Example: **+ H9-SW-NA**



Molded Case Circuit Breakers and Disconnect Switches Accessories for NZM(H) 9...

1	2	3	4	5	6
	Color of handle	Can be used with all devices of Type number	Type To be ordered with device only. Add below suffix	Type	Price \$
<p>Rear operation shafts For side panel mounting where device is only accessible from the rear (e.g. sides of enclosure panels). Must be combined with Type H...R rear operation handles. Factory installed only. Order with device.</p>		NZM(H) 9... N 9...	+R-NZM 9		See Price List See Price List
<p>Operating Handle for rear operation Used with rear operation shaft. Degree of protection: UL/NEMA 3R, 12; IEC IP 55 Can be locked in the OFF position with up to three padlocks (hasp thickness 6 – 8 mm). No cover/door interlocking provisions. 3 distinct Handle positions: OFF, + (tripped), ON Red -Yellow version for Emergency-Stop function.</p>	Gray	NZM(H) 9... N 9...	—	H 9-R-NA	See Price List See Price List
	Black	NZM(H) 9... N 9...	—	H 9-R-SW-NA	See Price List See Price List
	Red/ Yellow	NZM(H) 9... N 9...	—	RH 9-R-NA	See Price List See Price List
<p>Legend Plate (for mounting with operating handle) Silver-colored, black lettering</p>					
		NZM(H) 9... N 9...	—	ZSSOND-NZM 9	See Price List See Price List
Specify desired text. Height of letters: 3.5, 5, and 7 mm					
Blank (for engraving or printing)		NZM(H) 9... N 9...	—	ZS60-NZM 9	See Price List See Price List
Main Disconnect Warning plates. English Inscription: "Main Switch- Open only in OFF position" Silver-colored, black lettering		NZM(H) 9... N 9...	—	ZS62-NZM 9	See Price List See Price List
Also available in other languages:		NZM(H) 9... N 9...	—	ZS...-NZM 9	See Price List See Price List
<p>Afrikaans (81) Bulgarian (64) Czech (78) Danish (65) Dutch (67) Finnish (66) French (63) German (61) Greek (69) Hungarian (80) Italian (68) Norwegian (70) Polish (71) Portuguese (72) Romanian (73) Russian (74) Serbo-Croatian (76) Spanish (77) Swedish (75) Turkish (79)</p>					
Insert key number into Type. Example: ZS68-NZM 9 (Inscription in Italian language)					

Ordering Information:

Specify Type from Column 5. Example: **H9-R-SW-NA**.

If ordering with device, just add a "+" in front of the Type number. Example: **+ H9-R-SW-NA**





Note:

Items in Column 4 are factory installed and must be ordered with the device.



Molded Case Circuit Breakers and Disconnect Switches

Handle kits for NZM(H) 9...

1	2	3	4
		Type	Price
			\$
<p>Main Disconnect Switch Assembly Kits for CE marked control panels per IEC/EN 60 204-1 Type NZM(H) 9-... switches with dual UL/CSA and IEC/EN ratings are suitable for use as Main Disconnect switches in control panels that must be CE marked and designed to comply with the Machinery Directive standard EN 60 204-1. The kits shown below, ordered with the device or separately, will provide the necessary accessories to fulfill the Main Disconnect switch function for these applications. Note: In cases where the Main Disconnect switch also fulfills the Emergency-Stop function, please specify kits containing red handle and yellow backing plate assemblies.</p>			
<p>Kit includes: Main Disconnect handle with door/cover interlock for front mounting, red color handle with yellow backing plate for Emergency-Stop function, terminal cover and Main Switch marking plate.</p>		<p>V-NZM 9</p>	<p>See Price List</p>
<p>Kit includes: Main Disconnect handle for rear operated switches, red in color with yellow backing plate for Emergency-Stop function, supplied with a steel plate for panel side-mounting, terminal cover and Main Switch marking plate</p>		<p>EA-NZM 9</p>	<p>See Price List</p>
<p>Kit includes: Same as V-NZM 9, except that the Main Disconnect handle is black in color with silver backing plate for standard, non-Emergency-Stop function.</p>		<p>V-NZM 9-SW</p>	<p>See Price List</p>
<p>Kit includes: Same as EA-NZM 9, except that the Main Disconnect handle is black in color with silver backing plate for standard, non-Emergency-Stop function.</p>		<p>EA-NZM 9-SW</p>	<p>See Price List</p>

Ordering Information:
 Specify Type from Column 3. Example: **V- NZM 9**
 If ordering with device, just add a "+" in front of the Type number. Example: **+ V- NZM 9**

Disconnect Switches, Molded Case Switches



Molded Case Circuit Breakers and Disconnect Switches Accessories for NZM(H) 9...



1	2	3	4
<p>Control Circuit Tap-Off Terminals Supplementary terminals attached to main terminals. 3 connections top and bottom. Factory addition only, must be ordered with device.</p> <p>Terminal Cover Provides shock hazard protection in the area of the field wiring power terminals. Can be used at top or bottom, one cover per side. Mandatory requirement on the supply side of Main Disconnect switches to provide protection against accidental contact with line side feed.</p>	<p>Type To be ordered with device only. Add suffix shown below</p> <p>+ST</p> <p>—</p>	<p>Type</p> <p>—</p> <p>H-NZM 9</p>	<p>Price</p> <p>\$</p> <p>See Price List See Price List See Price List See Price List</p>



Ordering Information:
 Accessory in Column 2 can only be ordered with device. Specify Type suffix. Example: **+ ST**
 Specify Type from Column 3. Example: **H-NZM 9**
 If ordering with device, just add a "+" in front of the Type number. Example: **+ H-NZM 9**

Inverse Time Circuit Breakers, 1000 Amps Solid State Trip, Type NZM 12...-NA

UL/CSA

1	2	3	4	5	6	7	
	Long Time Response Current Setting	Adjustable instantaneous Pick-up Setting	Adjustable Short Time Delay Pick-up setting for selectivity in networks Time delay Range: 0 – 1000 ms	UL/CSA Interrupting ratings (AC, 60Hz) RMS Sym Amps @		Type	Price
	Amps	Amps	Amps	240 V 480 V 600 V		Standard	\$
Fixed Long Time Response Setting Type NZM 12-.../ZM 12A-...-NA							
	400 500 600 700 800 1000	1200 – 12,000 1200 – 12,000 1200 – 12,000 1600 – 16,000 1600 – 16,000 2000 – 20,000	— — — — — —	65 kA 65 kA 50 kA		NZM 12-630/ZM 12A-400-NA NZM 12-630/ZM 12A-500-NA NZM 12-630/ZM 12A-600-NA NZM 12-800/ZM 12A-700-NA NZM 12-800/ZM 12A-800-NA NZM 12-1250/ZM 12A-1000-NA	See Price List See Price List See Price List See Price List See Price List See Price List
(1000 A)							
Adjustable Long Time Response Setting Type NZM 12-.../ZM 12-...-NA							
	300 – 600 400 – 800 500 – 1000	1200 – 12,000 1600 – 16,000 2000 – 20,000	— — —	65 kA 65 kA 50 kA		NZM 12-630/ZM 12-600-NA NZM 12-800/ZM 12-800-NA NZM 12-1250/ZM 12-1000-NA	See Price List See Price List See Price List
(1000 A)							
Adjustable Long Time response setting and Short-Time Delay pick-up for selectivity Type NZM 12-.../ZM 12 V-...-NA							
	300 – 600 400 – 800 500 – 1000	1200 – 12,000 1600 – 16,000 2000 – 20,000	600 – 7200 800 – 9600 1000 – 12,000	65 kA 65 kA 50 kA		NZM 12-630/ZM 12 V-600-NA NZM 12-800/ZM 12 V-800-NA NZM 12-1250/ZM 12 V-1000-NA	See Price List See Price List See Price List
(1000 A)							

Type **NZM 12-.../ZM 12(A)-...-NA** Molded Case Circuit Breakers are UL Listed (UL 489) and CSA Certified (22.2 Nr. 5.1) Inverse Time, Solid State Trip Circuit Breakers with a fixed or adjustable Long Time Response and adjustable instantaneous pick-up range.
 Type **NZM 12-.../ZM 12 V-...-NA** are UL Listed (UL 489) and CSA Certified (22.2 Nr. 5.1) and have an additional short time delay pick-up range for selectivity in energy distribution networks. The time delay response is adjustable from 0 to 1000 milliseconds.

Ordering Information:
 State type from Column 6. Example: **NZM 12-1250/ZM 12A-1000-NA**.

- Note:
- Operating Handle supplied separately. Consult page 8/36 for available handle types.
 - Consult page 8/34 - 39 for additional accessories.
 - Line and Load field-wiring terminals for cable connection supplied as standard. Refer to technical data for range of suitable conductor cross-sections.

Disconnect Switches, Molded Case Switches
Circuit Breakers



1	2	3				4	5
Frame Rating	Continuous Current Rating	Maximum HP Rating 3 Phase @				Type	Price
	Amps	200 V HP	230 V HP	460 V HP	575 V HP		\$
N12-...-CNA Motor Disconnect Switches							
	600	200	250	450	600	N 12-630-CNA	See Price List See Price List
	800	250	300	600	750	N 12-800-CNA	
	1000	250	300	600	750	N 12-1000-CNA	
	1200	300	450	1000	1000	N 12-1200-CNA ¹⁾	





Type **N 12...-CNA** Disconnect Switches are UL recognized (UL 508) and CSA certified (22.2 Nr. 14) as 3 pole, HP rated non-automatic manual motor disconnects without any overload or short circuit tripping elements. Their switching mechanism has 3 positions (OFF, ON, + "Tripped") and they can be equipped with voltage trip accessories such as shunt trip and undervoltage trip coils.
UL/CSA Short Circuit Rating @ 600VAC: 42 kA RMS Sym.

Ordering Information:
State type from Column 4. Example: **N 12-800-CNA**

- Note:
- For direct-on-line switching of motors, use in combination with a listed magnetic contactor.
 - Operating Handle supplied separately. Consult page 8/36 for available handle types.
 - Consult page 8/34 - 39 for additional accessories.
 - Line and Load field-wiring terminals for cable connection supplied as standard.

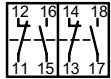
1) **N 12-1200-CNA** is supplied standard with bolt-on connection only. Field-wiring terminals for conductor hook-up (up to 4 x 500 kcmil, Cu or Al) can be supplied but must be ordered with the device. Add the following suffixes to the Type number.
Example: **N 12-1200-CNA**
+ **K 240AL-NZM 12-O** (for top mounted terminals, set of three)
+ **K 240AL-NZM 12-U** (for bottom mounted terminals, set of three)
See price list for adder.

Molded Case Circuit Breakers and Disconnect Switches Auxiliary Contacts for NZM 12...

1	2	3	4	5												
	Contacts	Type	Price	Notes												
	N.O. N.C.	To be ordered with device only. Add below suffix.	\$													
Standard Auxiliary Contacts ¹⁾	2 2	+NHI 22-NZM 12	See Price List	Combination possibilities of auxiliary contacts: <table border="0"> <tr> <td>NHI</td> <td>VHI</td> <td>AHI</td> <td>RHI</td> </tr> <tr> <td>●</td> <td>●</td> <td>—</td> <td>●</td> </tr> <tr> <td>●</td> <td>—</td> <td>●</td> <td>●</td> </tr> </table> Dots in each row represent the types which can be combined together. Dashes indicate incompatibility.	NHI	VHI	AHI	RHI	●	●	—	●	●	—	●	●
NHI	VHI	AHI	RHI													
●	●	—	●													
●	—	●	●													
			See Price List													
Early-Make Auxiliary Contacts	2 1	+VHI 21-NZM 12	See Price List													
			See Price List													
Handle operated Early-Make Auxiliary Contacts	2 1	+AHI 21-NZM 12	See Price List													
			See Price List													
Trip Indicating Auxiliary Contacts	2 1	+RHI 21-NZM 12	See Price List													
			See Price List													
1) The NHI 22-NZM 12 auxiliary contact comes standard with all versions of the NZM 12.../ZM 12...-NA Molded Case Circuit Breakers. It is an optional accessory only for the non-automatic N 12...-CNA disconnect switches and must be ordered with the device if desired.																

Type **NHI...** are standard auxiliary contacts. They operate simultaneously with the main contacts. They can be typically used for signalling or switching auxiliary circuits such as a control circuit.

Type **VHI...** are Early Make auxiliary contacts and lead the main contacts when switching ON as well as switching OFF. This makes them ideal for load shedding purposes or in conjunction with voltage trips in control circuits.

Type **AHI...** are handle operated Early Make auxiliary contacts. They operate in advance of the main contacts, shortly after the handle has left the OFF position. They can be typically used to convert the manual actuation of the switch into a control function for circuit interlocking purposes.

Type **RHI...** are trip indicating auxiliary contacts. They work independently of the normal ON and OFF operations of the device, switching only when the device has tripped due to overloads, overcurrents or other tripping functions such as voltage trips.

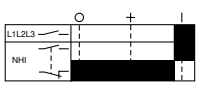
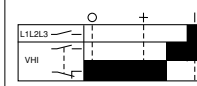
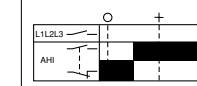
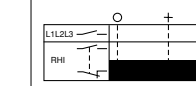
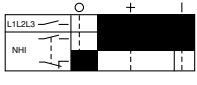
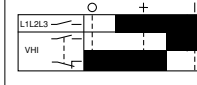
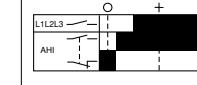
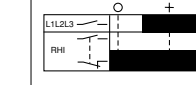
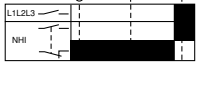
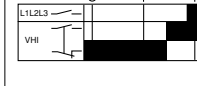
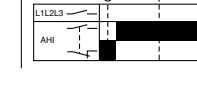
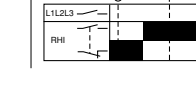

Refer to diagrams below for further details:

	NHI	VHI	AHI	RHI
Position of auxiliary contacts →	Same as main contacts	Same contact position in both OFF and Tripped position of the device.	Same contact position in both ON and Tripped position of the device.	Operates only when device is tripped (overload, short-circuit, shunt or undervoltage trips.)
Main Contacts: ■ Closed □ Open				
Switching ON ○ →				
Switching OFF ○ ←				
Tripped position + ←				

Ordering Information:
 Auxiliary Contacts must be ordered with device. Add type from Column 3.
 Example: **+ VHI 21-NZM 12**.





Molded Case Circuit Breakers and Disconnect Switches Voltage Trips for NZM 12...

1	2	3	4	5	6
	Rated Control Voltage		Type To be ordered with device only. Add below suffix.	Price	Notes
		V/Hz		\$	
Shunt Trips					
100% Continuous duty rating					
	AC	120V 60Hz	+A-NZM 12 (120V 60Hz)	See Price List	Shunt Trips are typically used to electrically trip the device from a remote location. The A-NZM 12... series is rated for 100% continuous duty. If desired, automatic disconnection of the shunt trip coil can be achieved by using the NHI auxiliary contact in series with the coil. Shunt Trips cannot be mounted together with Undervoltage Trips.
	AC	208V 60Hz	+A-NZM 12 (208V 60Hz)	See Price List	
	AC	240V 60Hz	+A-NZM 12 (240V 60Hz)	See Price List	
	AC	480V 60Hz	+A-NZM 12 (480V 60Hz)	See Price List	
	AC	600V 60Hz	+A-NZM 12 (600V 60Hz)	See Price List	
	DC	24 V	+A-NZM 12 (24V DC)	See Price List	
Undervoltage Trips					
	AC	120V 60Hz	+U-NZM 12 (120V 60Hz)	See Price List	Undervoltage Trips will electrically trip the device open under power loss and can be used for control interlocking purposes e.g. to disconnect the main switch in Emergency-Stop circuits. They are rated for continuous duty. Power can be applied to the undervoltage trip using VHI early-make auxiliary contacts in series with the undervoltage trip coil. Undervoltage Trips cannot be mounted together with Shunt Trips.
	AC	208V 60Hz	+U-NZM 12 (208V 60Hz)	See Price List	
	AC	240V 60Hz	+U-NZM 12 (240V 60Hz)	See Price List	
	AC	480V 60Hz	+U-NZM 12 (480V 60Hz)	See Price List	
	AC	600V 60Hz	+U-NZM 12 (600V 60Hz)	See Price List	
	DC	24V	+U-NZM 12 (24VDC)	See Price List	

Ordering Information:
Voltage trips must be ordered with device. Add type from Column 4.
Example: **+ U-NZM 12 (480V, 60Hz)**

Molded Case Circuit Breakers and Disconnect Switches Accessories for NZM 12...

1	2	3	4	5	6	
		Color of handle	Can be used with all devices of Type number	Type	Price	
					\$	
Handle for open or panel mounted devices Fastens to shaft, not padlockable			Gray	N(ZM)12...	H 12U	See Price List
			Black	N(ZM)12...	H 12U-SW	See Price List
Handle for Cover/Door Interlocking Degree of protection UL/NEMA 3R, 12; IEC IP 55 Door coupling rotary handle. For front mounting in doors and covers. Can be locked in the OFF position with up to three padlocks (hasp thickness 6 – 8 mm). Door/cover interlocking supplied standard set in OFF position. Can be field modified for setting in ON position. 3 distinct Handle positions: OFF - + (tripped) - ON Red -Yellow version for Emergency-Stop function.			Gray	N(ZM)12...	H 12-NA	See Price List
			Black	N(ZM)12...	H 12-SW-NA	See Price List
			Red/ Yellow	N(ZM)12...	RH 12-NA	See Price List
Extension shaft For mounting depths of 240 – 400 mm. Extends shaft length by 183 mm. Only one extension shaft possible. Can also be used with the mechanical interlock.				N(ZM)12...	A-NZM 12	See Price List
Switch position indicator Indicates position of switch when panel door is open.				N(ZM)12...	SA-NZM 12	See Price List
Maintenance Handle To actuate the device when the panel door is open.				N(ZM)12...	H 12UZ	See Price List
Mechanical Interlock For mechanical interlocking of two devices mounted side by side. Requires two handles, one for each switch. Order separately.				N(ZM)12...	KV-2 NZM 12	See Price List
For mechanical interlocking of two devices not mounted side by side. Requires two handles, one for each switch. Order separately.				N(ZM)12...	KVA-2 NZM 12	See Price List
For mechanically interlocking two main incomers with one emergency-supply device e.g. in emergency power supply systems. Handles ordered separately.				N(ZM)12...	KVA-3 NZM 12	See Price List



Ordering Information:

Specify Type from Column 5. Example: **H 12-SW-NA**

If ordering with device, just add a "+" in front of the Type number. Example: **+ H 12-SW-NA**



Molded Case Circuit Breakers and Disconnect Switches Accessories for NZM 12...

1	2	3	4	5	6
	Color of handle	Can be used with all devices of Type number	Type To be ordered with device only. Add below suffix	Type	Price \$
Rear operation shafts For side panel mounting where device is only accessible from the rear (e.g. sides of enclosure panels). Must be combined with Type H...R rear operation handles. Factory installed only. Order with device.		N(ZM) 12...	+R-NZM 12		See Price List See Price List
Operating Handle for rear operation Used with rear operation shaft. Degree of protection: UL/NEMA 3R, 12; IEC IP 55 Can be locked in the OFF position with up to three padlocks (hasp thickness 6 – 8 mm). No cover/door interlocking provisions. 3 distinct Handle positions: OFF - + (tripped) - ON Red -Yellow version for Emergency-Stop function.	Gray	N(ZM) 12...	—	H 12-R-NA	See Price List See Price List
	Black	N(ZM) 12...	—	H 12-R-SW-NA	See Price List See Price List
	Red/ Yellow	N(ZM) 12...	—	RH 12-R-NA	See Price List See Price List
Legend Plate (for mounting with operating handle) Silver-colored, black lettering					
					
Specify desired text. Height of letters: 3.5, 5, and 7 mm		N(ZM) 12...	—	ZSSOND-NZM 12	See Price List See Price List
Blank (for engraving or printing)		N(ZM) 12...	—	ZS60-NZM 12	See Price List See Price List
Main Disconnect Warning plates. English Inscription: "Main Switch- Open only in OFF position" Silver-colored, black lettering		N(ZM) 12...	—	ZS62-NZM 12	See Price List See Price List
Also available in other languages:		N(ZM) 12...	—	ZS...-NZM 12	See Price List See Price List
Afrikaans (81) Bulgarian (64) Czech (78) Danish (65) Dutch (67) Finnish (66) French (63) German (61) Greek (69) Hungarian (80) Italian (68) Norwegian (70) Polish (71) Portuguese (72) Romanian (73) Russian (74) Serbo-Croatian (76) Spanish (77) Swedish (75) Turkish (79)					
Insert key number into Type. Example: ZS63-NZM 12 (Inscription in French language)					

Ordering Information:

Specify Type from Column 5. Example: **H 12-R-SW-NA**.

If ordering with device, just add a "+" in front of the Type number. Example: **+ H 12-R-SW-NA**

Note:

Items in Column 4 are factory installed and must be ordered with the device.

Molded Case Circuit Breakers and Disconnect Switches Accessories for NZM 12...

1	2	3	4
	Type To be ordered with device only. Add suffix shown below	Type	Price \$
Control Circuit Tap-Off Terminals Supplementary terminals attached to main terminals. 3 connections top and bottom. Factory addition only, must be ordered with device.	+ST	—	See Price List See Price List
Terminal Cover Provides shock hazard protection in the area of the field wiring power terminals. Can be used at top or bottom, one cover per side. Mandatory requirement on the supply side of Main Disconnect switches to provide protection against accidental contact with line side feed.	—	H-NZM 12	See Price List See Price List
Test Unit for NZM 12 Circuit-Breakers Supply terminal voltage can be selected from 120/220/240 V, 50/60 Hz. The portable test unit can be used to verify that the long time, instantaneous and short-time delayed tripping characteristics of the circuit-breaker are operating per preset values. Various test voltages simulate a short-circuit or an overload condition which would cause the circuit-breaker to trip out. All measuring and connection leads, as well as operating instructions, are supplied with the unit.	—	P-NZM	See Price List See Price List

Disconnect Switches, Molded Case Switches

Circuit Breakers



Ordering Information:
 Accessory in Column 2 can only be ordered with device. Specify Type suffix. Example: **+ ST**
 Specify Type from Column 3. Example: **H-NZM 12**
 If ordering with device, just add a "+" in front of the Type number. Example: **+ H-NZM 12**

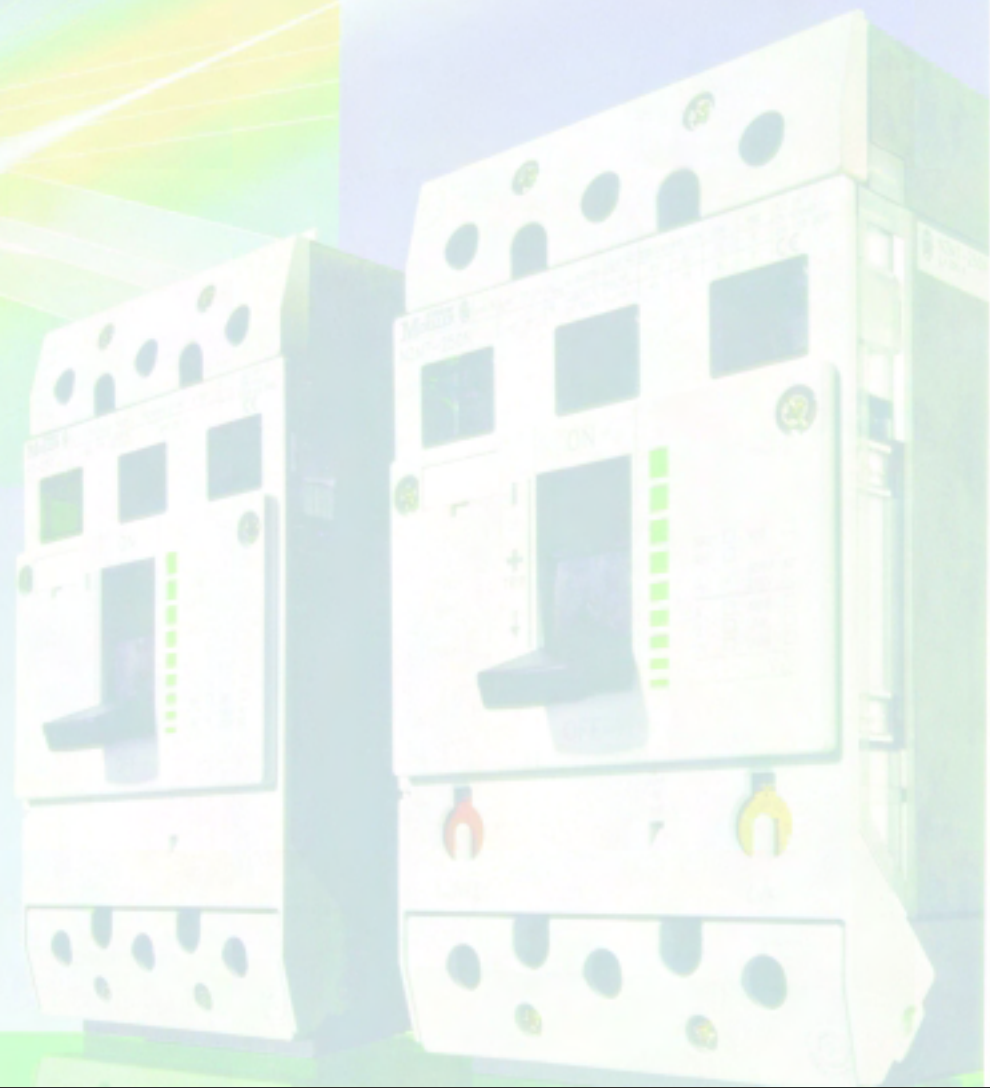

Circuit Breakers
Disconnect Switches, Molded Case Switches



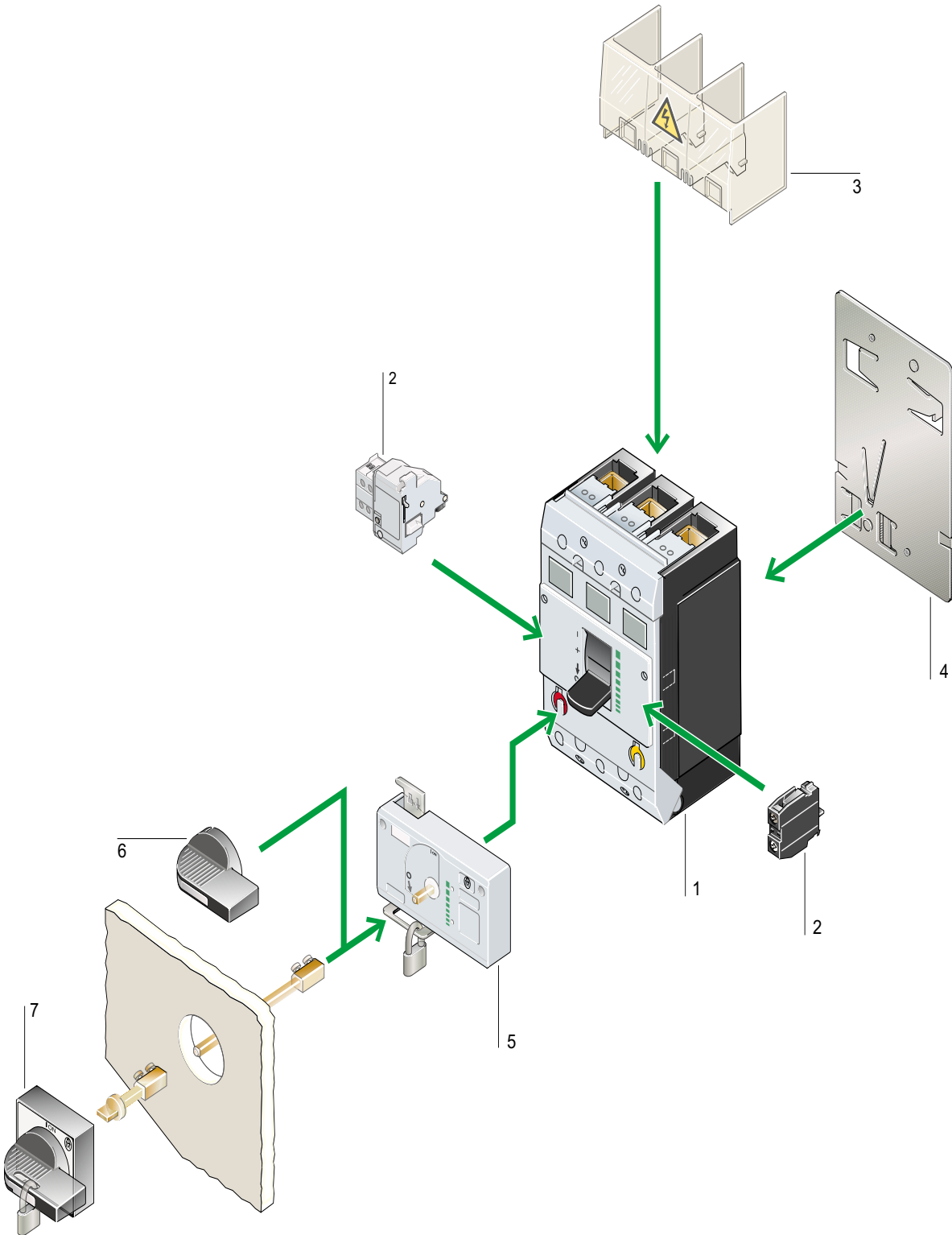

Disconnect Switches, Molded Case Switches
Circuit Breakers

8

- | | |
|---|--|
| <p>1 Molded Case Breaker – Page 8/44
 480 V AC, 150 Amp rating
 25 kA @ 480 VAC Interrupting rating
 Field installable accessories
 Supplied with terminals for cable hookup or bolt-on connection.
 UL Listed (UL 489), CSA certified (C 22.2 # 5.1)
 Conformity with (Circuit Breakers) IEC/EN 60 947-2 (pending)</p> <p>1 Molded Case Switch – Page 8/45
 600 VAC, 200 Amp rating
 Field installable accessories
 UL Listed (UL 1087), CSA certified (C 22.2 # 5.2)
 Conformity with IEC/EN 60 947-3 (Switch-Disconnectors)</p> <p>2 Auxiliary Contacts – Page 8/46
 (Pictured right of toggle switch)
 Type NHI... standard auxiliary contact:
 <i>For signalling ON and OFF positions</i>
 Type RHI... trip-indicating auxiliary contact:
 <i>For signalling the Tripped (“+”) position</i></p> <p>2 Auxiliary Contacts & Voltage Trips – Page 8/47...49
 (Pictured left of toggle switch)
 Type VHI... Early-Make auxiliary contact:
 <i>For interlocking and load shedding purposes.</i>
 <i>To power up the undervoltage trip prior to main contact closing</i>
 Shunt Trips
 AC & DC versions
 With and without Early-Make auxiliary contacts
 Undervoltage Trips
 AC & DC versions
 With and without Early-Make auxiliary contacts</p> <p>3 Terminal Cover – Page 8/53
 Provides shock hazard protection against accidental contact with live terminals.
 Mandatory use in Main Disconnect switch applications for CE panels in conformity with IEC/EN 60 204-1</p> | <p>4 Clip Plate– Page 8/52
 Enables mounting of the NZM 7 on a DIN rail conforming to EN 50 022 specifications.</p> <p>5 Rotary Drive Mechanism – Page 8/50
 Converts toggle switch operation of the switch into a rotary movement suitable for rotary style operators.
 Lockable in the OFF position. (Optional)</p> <p>6 Rotary Handle – Page 8/50
 To operate switch equipped with rotary drive mechanism.</p> <p>7 Door/Cover Interlocking Rotary Handle – Page 8/50
 For cover or door mounting.
 Interlocking feature to prevent opening of door or cover with the switch in the ON position.
 Padlockable in the OFF or ON position with up to 3 padlocks (hasp size: 1/4", 4 – 8mm). (Optional. Also comes without padlockable feature.)
 Standard color: Black. Also available in red-yellow for Emergency-Stop function per CE and IEC/EN 60 204-1 specifications.
 Degree of protection: UL/NEMA 12, IEC/EN: IP 55.</p> |
|---|--|

Molded Case Circuit Breakers and Switches

Overview of Combination Options for Type NZM 7...



Auxiliary contacts

- (NHI...: Standard)
- (RHI...: Trip Indicating)
- (VHI...: Early-Make)

Voltage Trips

- (A...: Shunt Trip)
- (AVHI...: Shunt Trip with Early-Make Auxiliary Contact)
- (U...: Undervoltage Trip)
- (UHI...: Undervoltage Trip with Early-Make Auxiliary Contact)



EK...
(NHI)



EK...
(RHI)



VHI-NZM 7



A-NZM 7



AVHI-NZM 7



U-NZM 7

UHI NZM 7

**Molded Case Circuit Breakers
NZM 7(A)...N-NA**

●	●	●	or	●	or	●	or	●	or	●
---	---	---	----	---	----	---	----	---	----	---

**Molded Case Switches
NZM 7...-NA**

●	●	●	or	●	or	●	or	●	or	●
---	---	---	----	---	----	---	----	---	----	---

**Molded Case Circuit Breakers
+ Remote Control Drive
NZM 7(A)...N-NA + R-NZM 7**

●	●	—		●		—	or	●		—
---	---	---	--	---	--	---	----	---	--	---

**Molded Case Switches
+ Remote Control Drive
NZM 7...-NA + R-NZM 7**

●	●	—		●		—	or	●		—
---	---	---	--	---	--	---	----	---	--	---

● Dots in each row represent the accessories which can be combined together in the types shown at left.

○ Circles indicate supplied as standard.

— Dashes indicate incompatibility.

All accessories can be field or factory installed.

Disconnect Switches, Molded Case Switches
Circuit Breakers

Molded Case Circuit Breakers and Switches Overview of Combination Options for Type NZM 7...

Remote Control Drive

Handle Operators

Connection systems



Rotary Drive Mechanism



Rotary handle



Cover/Door Interlocking Rotary handle NEMA/UL Type 12; IP 55



Cable Terminals (included as standard)

Bolt-on Connection (Optional)

R-NZM 7

DA(OV)-NZM 7

HU(Z)-NZM 7

(R)H-NZM 7

HOV-NZM 7

NZM 7(A)...N-NA-M8
NZM 7 ...-NA-M8

● or	●	● or	● or	●	○	●
● or	●	● or	● or	●	○	●
○	—	—	—	—	○	●
○	—	—	—	—	○	●

1	2	3	4	5	6	7	8
	Continuous Current Rating I_u Amps	Fixed Thermal Setting Amps	Adjustable Thermal Setting Amps	Magnetic Trip Setting for Instantaneous Response Amps	UL/CSA Interrupting ratings (AC, 60Hz) RMS Sym Amps @ 240V 480V 600V	Type	Price \$

**Pressure-wire terminals and fixed thermal setting
Type NZM 7A-...S-NA**



(150A)

40	25	—	Fixed: $9.5 \times I_u$	100kA 50kA 22kA
	30	—		
	35	—		
	40	—		
60	50	—	Adjustable Range: $6 - 12 \times I_u$	
	60	—		
80	70	—		
	80	—		
100	90	—		
	100	—		
125	125	—		
150	150	—		

- NZM 7A-25S-NA
- NZM 7A-30S-NA
- NZM 7A-35S-NA
- NZM 7A-40S-NA
- NZM 7A-50S-NA
- NZM 7A-60S-NA
- NZM 7A-70S-NA
- NZM 7A-80S-NA
- NZM 7A-90S-NA
- NZM 7A-100S-NA
- NZM 7A-125S-NA
- NZM 7A-150S-NA

**Pressure-wire terminals and adjustable thermal setting
Type NZM 7A-...S-NA**

40	—	25 – 40	$9.5 \times I_u$	100kA 50kA 22kA
60	—	40 – 60	$6 - 12 \times I_u$	
80	—	60 – 80		
100	—	80 – 100		
125	—	100 – 125		
150	—	125 – 150		

- NZM 7-40S-NA
- NZM 7-63S-NA
- NZM 7-80S-NA
- NZM 7-100S-NA
- NZM 7-125S-NA
- NZM 7-150S-NA

**Fixed thermal setting and provisions for bolt-on connection
Type NZM 7A-...S-NA**

40	25	—	Fixed: $9.5 \times I_u$	100kA 50kA 22kA
	30	—		
	35	—		
	40	—		
60	50	—	Adjustable Range: $6 - 12 \times I_u$	
	60	—		
80	70	—		
	80	—		
100	90	—		
	100	—		
125	125	—		
150	150	—		

- NZM 7A-25S-NA-M8
- NZM 7A-30S-NA-M8
- NZM 7A-35S-NA-M8
- NZM 7A-40S-NA-M8
- NZM 7A-50S-NA-M8
- NZM 7A-60S-NA-M8
- NZM 7A-70S-NA-M8
- NZM 7A-80S-NA-M8
- NZM 7A-90S-NA-M8
- NZM 7A-100S-NA-M8
- NZM 7A-125S-NA-M8
- NZM 7A-150S-NA-M8

**Adjustable thermal setting and provisions for bolt-on connection
Type NZM 7-...S-NA**

40	—	25 – 40	$9.5 \times I_u$	100kA 50kA 22kA
60	—	40 – 60	$6 - 12 \times I_u$	
80	—	60 – 80		
100	—	80 – 100		
125	—	100 – 125		
150	—	125 – 150		



- NZM 7-40S-NA-M8
- NZM 7-63S-NA-M8
- NZM 7-80S-NA-M8
- NZM 7-100S-NA-M8
- NZM 7-125S-NA-M8
- NZM 7-150S-NA-M8

Ordering Information: Specify Type from Column 7.
Example: **NZM 7A-25S-NA**

For accessories see pages 8/46 - 53 in the Main Catalog USA 2000 / 2001

1) Conformity with IEC/EN 60 947-2 pending.



1	2	3	4	5	6	7	8	
	Continuous Current Rating	Fixed Thermal Setting	Adjustable Thermal Setting	Magnetic Trip Setting for Instantaneous Response	UL/CSA Interrupting ratings (AC, 60Hz) RMS Sym Amps @	Type	Price	
	I_u Amps	Amps	Amps	Amps	240 V 480 V		\$	
Pressure-wire terminals and fixed thermal setting Type NZM 7A...N-NA								
 (150A)	40	25 30 35 40	— — — —	Fixed: $9.5 \times I_u$	65 kA 25 kA	NZM 7A-25N-NA NZM 7A-30N-NA NZM 7A-35N-NA NZM 7A-40N-NA	See Price List See Price List See Price List See Price List	
	60	50 60 70 80 90 100 125 150	— — — — — — — —	Adjustable Range: $6 - 12 \times I_u$		NZM 7A-50N-NA NZM 7A-60N-NA NZM 7A-70N-NA NZM 7A-80N-NA NZM 7A-90N-NA NZM 7A-100N-NA NZM 7A-125N-NA NZM 7A-150N-NA	See Price List See Price List See Price List See Price List See Price List See Price List See Price List See Price List	
	Pressure-wire terminals and adjustable thermal setting Type NZM 7A...N-NA							
	40	—	25 – 40	$9.5 \times I_u$	65 kA 25 kA	NZM 7-40N-NA	See Price List	
	60	—	40 – 60	$6 - 12 \times I_u$		NZM 7-63N-NA NZM 7-80N-NA NZM 7-100N-NA NZM 7-125N-NA NZM 7-150N-NA	See Price List See Price List See Price List See Price List See Price List	
	80	—	60 – 80					
	100	—	80 – 100					
125	—	100 – 125						
150	—	125 – 150						
Fixed thermal setting and provisions for bolt-on connection Type NZM 7A...N-NA								
	40	25 30 35 40	— — — —	Fixed: $9.5 \times I_u$	65 kA 25 kA	NZM 7A-25N-NA-M8 NZM 7A-30N-NA-M8 NZM 7A-35N-NA-M8 NZM 7A-40N-NA-M8	See Price List See Price List See Price List See Price List	
	60	50 60 70 80 90 100 125 150	— — — — — — — —	Adjustable Range: $6 - 12 \times I_u$		NZM 7A-50N-NA-M8 NZM 7A-60N-NA-M8 NZM 7A-70N-NA-M8 NZM 7A-80N-NA-M8 NZM 7A-90N-NA-M8 NZM 7A-100N-NA-M8 NZM 7A-125N-NA-M8 NZM 7A-150N-NA-M8	See Price List See Price List See Price List See Price List See Price List See Price List See Price List See Price List	
	Adjustable thermal setting and provisions for bolt-on connection Type NZM 7...N-NA							
	40	—	25 – 40	$9.5 \times I_u$	65 kA 25 kA	NZM 7-40N-NA-M8	See Price List	
	60	—	40 – 60	$6 - 12 \times I_u$		NZM 7-63N-NA-M8 NZM 7-80N-NA-M8 NZM 7-100N-NA-M8 NZM 7-125N-NA-M8 NZM 7-150N-NA-M8	See Price List See Price List See Price List See Price List See Price List	
	80	—	60 – 80					
	100	—	80 – 100					
125	—	100 – 125						
150	—	125 – 150						

Ordering Information: Specify Type from Column 7.
Example: **NZM 7A-25N-NA**.

1) Conformity with IEC/EN 60 947-2 pending. Consult the technical data at the back of this section and Moeller Electric for IEC/EN ratings.

Disconnect Switches, Molded Case Switches
Circuit Breakers

1	2	3	4	5
	Ampere Rating	Type	Price	Notes
	Amps			
Molded Case Switches With pressure wire terminals for cable connection				UL/CSA Short Circuit Current Rating:
	60	NZM 7-60-NA	See Price List	With 225 A Fuse Backup: - 50 kA RMS Sym @ 600 VAC
	100	NZM 7-100-NA	See Price List	With 250 A Circuit-Breaker Backup: - 25 kA RMS Sym @ 480 VAC - 18 kA RMS Sym @ 600 VAC
	125	NZM 7-125-NA	See Price List	
	150	NZM 7-150-NA	See Price List	
	200	NZM 7-200-NA	See Price List	
Molded Case Switches With provisions for bolt-on connection				
	60	NZM 7-60-NA-M8	See Price List	
	100	NZM 7-100-NA-M8	See Price List	
	125	NZM 7-125-NA-M8	See Price List	
	150	NZM 7-150-NA-M8	See Price List	
	200	NZM 7-200-NA-M8	See Price List	

Type **NZM 7(A)---NA(M8)** Molded Case Circuit Breakers (opposite page) are UL Listed (UL 489) and CSA Certified (22.2 Nr. 5.1) Inverse Time, 150A Thermal-Magnetic Circuit Breakers that are available with either a fixed or adjustable thermal trip feature and an adjustable magnetic trip function. (In Breakers rated 25 to 40 Amp, the magnetic trip function is fixed at 9.5 x 40A (lu) i.e. 385A).

Type **NZM 7---NA(-M8)** Molded Case Switches (shown above) are virtually identical in construction to the Molded Case Circuit Breakers except that they are manual, non-automatic switches without any overload or overcurrent protective features, and are rated up to 200Amps.

All Molded Case Switches are UL Listed (UL 1087) and CSA certified (C 22.2 Nr. 5.2). They also are in Conformity with IEC/EN 60 947-3 (Switch-Disconnectors) and are CE marked. (Consult the Technical Data at the end of this section and Moeller Electric for IEC/EN ratings.)



Molded Case Switches are tested to determine their acceptability for continuous operation at their marked rated load. In addition, they are tested at six times their full ampere rating to cover motor circuit applications and are suitable for use as motor circuit disconnects per Section 430-109 of the National Electrical Code.

Both breakers and switches are supplied as standard with pressure wire terminals to accept cable connection, but are also suitable for bolt-on connections using crimped lugs or straight lengths of Cu busbar (Type suffix “-M8”).

Accessories such as voltage trips, auxiliary contacts, rotary handles etc... are common to all **NZM 7** circuit breakers and molded case switches and are UL listed and CSA certified for field installation.

Ordering Information:
Specify Type from Column 3. Example: **NZM 7-60-NA**.

Molded Case Circuit Breakers and Switches Auxiliary Contacts for Type NZM 7...-NA

1	2	3	4	5	6
		Contact sequence	Type	Price	Notes
				\$	
NHI Standard auxiliary contacts Switching simultaneously with the main contacts. They can be typically used for signalling, interlocking or switching auxiliary circuits such as a control circuit.		1.13 1.14	N.O. EK 10	See Price List	Two EK... NHI type contacts can be snap fitted into the Circuit Breaker or Molded Case Switch.
		1.11 1.12	N.C. EK 01	See Price List	
VHI Early-Make auxiliary contacts Leading the main contacts when switching ON as well as switching OFF. Ideal for load shedding purposes or in conjunction with voltage trips in control circuits.		3.13 3.33 3.14 3.34	2 X E.M. VHI-NZM 7	See Price List	One VHI...Type contact module per Circuit Breaker or Molded Case Switch. Cannot be used in conjunction with the R-NZM 7 Remote Control Drive.
				See Price List	
RHI Trip-indicating auxiliary contacts Actuating independently of the normal ON and OFF operations of the device, switching only when the device has tripped due to overcurrents or other tripping causes such as those initiated by voltage trips.		4.13 4.14	N.O. EK 10	See Price List	One EK... RHI type contact (either N.O. or N.C.) can be snap fitted into the Circuit Breaker or Molded Case Switch for trip indication.
		4.13 4.14	N.C. EK 01	See Price List	

Auxiliary Contacts are field installable.

Ordering information:
Specify Type from column 4.
Example: **EK 10**

If ordering with device, just specify a "+" in front of the Type number. Example: **+ EK 10**





Auxiliary Contacts and Voltage Trips can be combined as follows:

NHI 2 x EK...	RHI 1 x EK...	VHI	A	AVHI	U	U(V)HI
●	●	●	—	—	—	—
●	●	—	●	—	—	—
●	●	—	—	●	—	—
●	●	—	—	—	●	—
●	●	—	—	—	—	●

Dots in each row represent the types which can be combined together. Dashes indicate incompatibility.

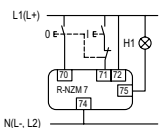
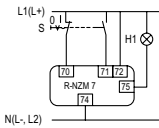
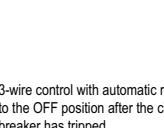
Disconnect Switches, Molded Case Switches
Circuit Breakers

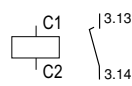
Molded Case Circuit Breakers and Switches Remote Control Drive and Shunt Trips for Type NZM 7...-NA

	2	3	4	5
	Rated Actuating Voltage (U _s)	Type	Price \$	Notes
Remote Control Drive				
Operates the NZM 7 Circuit Breaker or Molded Case Switch electrically from a remote location. Switching Times: ON 100ms, OFF 100ms Local manual operation of the switch possible. Field installable.	AC/DC	110...120	R-NZM 7 (110-120V)	  3-wire control 2-wire control  3-wire control with automatic reset to the OFF position after the circuit-breaker has tripped
	AC/DC	220...240	R-NZM 7 (220-240V)	
	DC	24	R-NZM 7 (24V)	
	DC	48...60	R-NZM 7 (48-60V)	
Shunt Trips				
Shunt Trips are typically used to electrically trip the device from a remote location. The A...-NZM 7 series is rated for 100% continuous duty. Shunt Trips cannot be mounted together with Undervoltage Trips.				
Shunt Trips without Auxiliary Contacts  	AC/DC ¹⁾	12 24 48 60 110-120 125-130 208-215 220-240 380-415 440-480	A-NZM 7 (12V) A-NZM 7 (24V) A-NZM 7 (48V) A-NZM 7 (60V) A-NZM 7 (110-120V) A-NZM 7 (125-130V) A-NZM 7 (208-215V) A-NZM 7 (220-240V) A-NZM 7 (380-415V) A-NZM 7 (440-480V)	Field installable and suitable for mounting into NZM 7 Circuit Breakers and Molded Case Switches. Shunt Trips are rated for both AC and DC voltages and can accommodate a frequency range between 0 and 400 Hz.
Shunt Trips with Early-Make auxiliary contacts  	AC/DC ¹⁾	12 24 48 60 110-120 125-130 208-215 220-240 380-415 440-480	AVHI-NZM 7 (12V) AVHI-NZM 7 (24V) AVHI-NZM 7 (48V) AVHI-NZM 7 (60V) AVHI-NZM 7 (110-120V) AVHI-NZM 7 (125-130V) AVHI-NZM 7 (208-215V) AVHI-NZM 7 (220-240V) AVHI-NZM 7 (380-415V) AVHI-NZM 7 (440-480V)	Field installable and suitable for mounting into NZM 7 Circuit Breakers and Molded Case Switches. Shunt Trips are rated for both AC and DC voltages and can accommodate a frequency range between 0 and 400 Hz. The Shunt Trip and Early-Make contacts operate independently of one another. Note: The Early-Make feature of the contact is not effective when it is combined with the R-NZM 7 Remote Control Drive.

Accessories are field installable.

Ordering information:
Specify Type from column 3.
Example: **A-NZM 7 (110-120V)**

If ordering with device, just specify a "+" in front of the Type number.
Example: **+ A-NZM 7 (110-120V)**

Auxiliary Contacts and Voltage Trips can be combined as follows:



NHI 2 x EK...	RHI 1 x EK...	VHI	A	AVHI	U	U(V)HI
●	●	●	—	—	—	—
●	●	—	●	—	—	—
●	●	—	—	●	—	—
●	●	—	—	—	●	—
●	●	—	—	—	—	●

Dots in each row represent the types which can be combined together. Dashes indicate incompatibility.

1) Maximum UL/CSA DC voltage is 125 VDC.



A Molded Case Circuit Breakers and Switches Undervoltage Trips for Type NZM 7...-N

1	2	3	4			
	Rated Actuating Voltage (U _s)	Type suffix	Price			
			\$			
Undervoltage Trips						
Undelayed response						
Undervoltage Trips will electrically trip the device open under power loss (when supply voltage drops below 35 – 70% of rated trip coil value) and can be used for control interlocking purposes e.g. to disconnect the main switch in Emergency-Stop circuits. They are rated for continuous duty. Undervoltage Trips cannot be mounted together with Shunt Trips.						
Undervoltage Trips without Auxiliary Contacts						
 	AC	24	U-NZM 7 (24V AC)	See Price List	See Price List	
		48	U-NZM 7 (48V AC)	See Price List	See Price List	
		60	U-NZM 7 (60V AC)	See Price List	See Price List	
		110 – 120	U-NZM 7 (110-120V AC)	See Price List	See Price List	
		125 – 130	U-NZM 7 (125-130V AC)	See Price List	See Price List	
		208 – 215	U-NZM 7 (208-215V AC)	See Price List	See Price List	
		220 – 240	U-NZM 7 (220-240V AC)	See Price List	See Price List	
		380 – 415	U-NZM 7 (380-415V AC)	See Price List	See Price List	
		440 – 480	U-NZM 7 (440-480V AC)	See Price List	See Price List	
		DC	24	U-NZM 7 (24V DC)	See Price List	See Price List
			48	U-NZM 7 (48V DC)	See Price List	See Price List
			60	U-NZM 7 (60V DC)	See Price List	See Price List
			110 – 120	U-NZM 7 (110-120V DC)	See Price List	See Price List
			125	U-NZM 7 (125-130V DC)	See Price List	See Price List

Disconnect Switches, Molded Case Switches
Circuit Breakers

Undervoltage Trips are field installable.

Ordering information:
Specify Type from column 3.
Example: **U-NZM 7 (110-120V AC)**

If ordering with device, just specify a “+” in front of the Type number.
Example: **+ U-NZM 7 (110-120V AC)**

Auxiliary Contacts and Voltage Trips can be combined as follows:

NHI 2 x EK...	RHI 1 x EK...	VHI	A	AVHI	U	U(V)HI
●	●	●	—	—	—	—
●	●	—	●	—	—	—
●	●	—	—	●	—	—
●	●	—	—	—	●	—
●	●	—	—	—	—	●

Dots in each row represent the types which can be combined together. Dashes indicate incompatibility.

Molded Case Circuit Breakers and Switches Undervoltage Trips for Type NZM 7...-NA

1	2	3	4
	Rated Actuating Voltage (U _s)	Type suffix	Price
			\$

Undervoltage Trips

Undelayed response

Undervoltage Trips will electrically trip the device open under power loss (when supply voltage drops below 35 – 70% of rated trip coil value) and can be used for control interlocking purposes e.g. to disconnect the main switch in Emergency-Stop circuits. They are rated for continuous duty.

Undervoltage Trips cannot be mounted together with Shunt Trips.

Undervoltage Trips with Early-Make Auxiliary ¹⁾

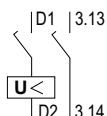

AC	Rated Voltage (U _s)	Type suffix	Price
	24	UHI-NZM 7 (24V AC)	See Price List
	48	UHI-NZM 7 (48V AC)	See Price List
	60	UHI-NZM 7 (60V AC)	See Price List
	110 – 120	UHI-NZM 7 (110-120V AC)	See Price List
	125 – 130	UHI-NZM 7 (125-130V AC)	See Price List
	208 – 215	UHI-NZM 7 (208-215V AC)	See Price List
	220 – 240	UHI-NZM 7 (220-240V AC)	See Price List
	380 – 415	UHI-NZM 7 (380-415V AC)	See Price List
	440 – 480	UHI-NZM 7 (440-480V AC)	See Price List
DC	24	UHI-NZM 7 (24V DC)	See Price List
	48	UHI-NZM 7 (48V DC)	See Price List
	60	UHI-NZM 7 (60V DC)	See Price List
	110 – 120	UHI-NZM 7 (110-120V DC)	See Price List
	125	UHI-NZM 7 (125-130V DC)	See Price List

Undervoltage Trips are field installable.

Ordering information:

Specify Type from column 3.

Example: **UHI-NZM 7 (110-120V AC)**

If ordering with device, just specify a “+” in front of the Type number.

Example: **+ UHI-NZM 7 (110-120V AC)**







Auxiliary Contacts and Voltage Trips can be combined as follows:

NHI 2 x EK...	RHI 1 x EK...	VHI	A	AVHI	U	U(V)HI
●	●	●	—	—	—	—
●	●	—	●	—	—	—
●	●	—	—	●	—	—
●	●	—	—	—	●	—
●	●	—	—	—	—	●

Dots in each row represent the types which can be combined together. Dashes indicate incompatibility.

1) Cannot be used in conjunction with **R-NZM 7** Remote Control Drive.

Molded Case Circuit Breakers and Switches Accessories for Type NZM 7...-NA

1	2	3	4	5
		Type	Price	Notes
			\$	
	<p>Insulating frame for door cutout (IP 40) Fits around the cutout area of the panel door through which the toggle mechanism on the front part of the switch protrudes.</p> 	RT-NZM 7	See Price List	Fastened from the back using screws. Can be inscribed.
	<p>Rotary Drive Mechanism Converts ON and OFF switching from a toggle motion to a rotary motion</p> <p>Without padlocking feature</p>  <p>With additional padlocking feature</p>	DAOV-NZM 7 DA-NZM 7	See Price List See Price List	Can be locked in the OFF position with up to 3 padlocks. Hasp thickness 4 – 8 mm.
	<p>Rotary handle for open or panel mounted switches Black color. Rotary Drive Mechanism required. Fastens to shaft, not padlockable</p> 	HU-NZM 7	See Price List	
	<p>Handle for Cover/Door Interlocking Degree of protection UL/NEMA 12; IEC IP 55 Door coupling rotary handle. For front mounting in doors and covers. Door/cover interlocking supplied standard set in OFF position. 3 distinct Handle positions: OFF - + (tripped) - ON.</p> <p>Black color (Standard)</p>  <p>Red-yellow For use as an Emergency-Stop Main Disconnect switch per IEC/EN 60204-1 (CE, Machinery Directive)</p>  <p>Black, without padlocking feature</p> 	H-NZM 7-NA RH-NZM 7-NA HOV-NZM 7-NA	See Price List See Price List See Price List	Note: Rotary Drive Mechanism required. Handles can be locked in the OFF or ON position with up to 3 padlocks. Hasp thickness 4 – 8 mm. Handle position is fixed when door or cover is open. Same features as the H-NZM 7-NA except that the padlocking feature is omitted.
	<p>Extension shaft Can be cut to required length For mounting depths in the range of 175 – 400 mm</p>  <p>For mounting depths in the range of 260 – 600 mm</p>	A400-NZM 7 A600-NZM 7	See Price List See Price List	



Ordering information

Specify Type from column 3. Example: **H-NZM 7-NA**

If ordering with device, just specify a "+" in front of the Type number. Example: **+ H-NZM 7-NA**.



Molded Case Circuit Breakers and Switches Accessories for Type NZM 7...-NA

1	2	3	4	5																				
		Type	Price	Notes																				
			\$																					
	<p>Side wall operator Enables actuation of the switch from its left or right side as opposed to the front.</p> <p>For operation on the left</p> <p>For operation on the right</p> 	<p>SWA-NZM 7-L</p> <p>SWA-NZM 7-R</p>	<p>See Price List</p> <p>See Price List</p>	<p>The SWA shifts the rotary movement of the switch by 90° and permits the rotary handle to mount and actuate the switch from the side of the control panel enclosure.</p> <p>The SWA... mechanism mounts directly on top of the DA(OV) Rotary Drive Mechanism.</p> <p>An extension shaft (280 mm) with a special coupling piece is supplied with the unit.</p>																				
	<p>Mounting bracket for side-panel mounting</p> 	<p>MSWA-NZM 7</p>	<p>See Price List</p>	<p>For mounting the switch directly into the side panel of the enclosure.</p> <p>For use only with SWA... side wall operator equipped switches.</p>																				
	<p>Main Disconnect Switch Assembly Kits for CE marked control panels per IEC/EN 60 204-1 (Machinery Directive)</p> <p>With door interlocking rotary handle. Color: Black for standard Main Disconnect function</p> <p>With door interlocking rotary handle. Color: Red-Yellow for Main Disconnect switches fulfilling the Emergency-Stop function.</p>	<p>V-NZM 7-SW</p> <p>V-NZM 7</p>	<p>See Price List</p> <p>See Price List</p>	<p>These kits provide the necessary accessories to fulfill the Main Disconnect switch function per the Machinery Directive standard IEC 60 204-1.</p> <p>Note: In cases where the Main Disconnect switch also fulfills the Emergency-Stop function, please specify kits containing red handle and yellow backing plate assemblies.</p> <p>V... Kits contain:</p> <ul style="list-style-type: none"> • Door interlocking rotary handle • DAOV rotary drive • Extension shaft for 400 mm mounting depth • External warning plate • Black lightning symbol 																				
	<p>For side wall installation</p> <p>With black rotary handle</p> <p>For operation on the left</p> <p>For operation on the right</p> <p>With red-yellow rotary handle for use as Emergency-Stop devices to IEC/EN 60204-1</p> <p>For operation on the left</p> <p>For operation on the right</p>	<p>EA-NZM 7-L</p> <p>EA-NZM 7-R</p> <p>EA-RT-NZM 7-L</p> <p>EA-RT-NZM 7-R</p>	<p>See Price List</p> <p>See Price List</p> <p>See Price List</p> <p>See Price List</p>	<p>EA... Kits contain:</p> <ul style="list-style-type: none"> • Door coupling rotary handle • DAOV rotary drive • Side wall operator with extension shaft • Mounting brackets • External warning plate • Black lightning symbol 																				
	<p>External warning plate</p> <p>English text Inscription: "Main Switch – Open only in OFF position"</p> <p>Blank</p> <p>Other Languages</p>	<p>ZFS 62-NZM 7</p> <p>ZFS 60-NZM 7</p> <p>ZFS...-NZM 7</p>	<p>See Price List</p> <p>See Price List</p> <p>See Price List</p>	<p>External warning plates available in:</p> <table border="0"> <tr> <td>61 German</td> <td>72 Portuguese</td> </tr> <tr> <td>63 French</td> <td>73 Romanian</td> </tr> <tr> <td>64 Bulgarian</td> <td>74 Russian</td> </tr> <tr> <td>65 Danish</td> <td>75 Swedish</td> </tr> <tr> <td>66 Finnish</td> <td>76 Serbo-Croatia</td> </tr> <tr> <td>67 Dutch</td> <td>77 Spanish</td> </tr> <tr> <td>68 Italian</td> <td>78 Czech</td> </tr> <tr> <td>69 Greek</td> <td>79 Turkish</td> </tr> <tr> <td>70 Norwegian</td> <td>80 Hungarian</td> </tr> <tr> <td>71 Polish</td> <td>81 Afrikaans</td> </tr> </table> <p>To obtain warning plates in other languages, insert the language code number into the type reference. Example: External warning plate in French would be, ZFS 63-NZM 7</p>	61 German	72 Portuguese	63 French	73 Romanian	64 Bulgarian	74 Russian	65 Danish	75 Swedish	66 Finnish	76 Serbo-Croatia	67 Dutch	77 Spanish	68 Italian	78 Czech	69 Greek	79 Turkish	70 Norwegian	80 Hungarian	71 Polish	81 Afrikaans
61 German	72 Portuguese																							
63 French	73 Romanian																							
64 Bulgarian	74 Russian																							
65 Danish	75 Swedish																							
66 Finnish	76 Serbo-Croatia																							
67 Dutch	77 Spanish																							
68 Italian	78 Czech																							
69 Greek	79 Turkish																							
70 Norwegian	80 Hungarian																							
71 Polish	81 Afrikaans																							

Ordering information:
Specify Type from column 3. Example: **SWA-NZM 7- L**
If ordering with device, just specify a "+" in front of the Type number. Example: **+ SWA-NZM 7- L**

Molded Case Circuit Breakers and Switches Accessories for Type NZM 7...-NA

1	2	3	4	5
		Type	Price	
			\$	
Mechanical interlock		KV 2-NZM 7	See Price List	For interlocking two Type NZM 7... Circuit Breakers or Molded Case Switches
Clip plate 		C-NZM 7	See Price List	For mounting two Type NZM 7... Circuit Breakers or Molded Case Switches onto a DIN rail conforming to EN 50 022. Clip plate not suitable for switches equipped with R-NZM 7 Remote Control Drives.



Disconnect Switches, Molded Case Switches

Circuit Breakers



Ordering information:
 Specify Type from column 3. Example: **KV 2-NZM 7**
 If ordering with device, just specify a "+" in front of the Type number. Example: **+ KV 2-NZM 7**

Molded Case Circuit Breakers and Switches Accessories for Type NZM 7...-NA

1	2	3	4	5	6
	Type	Price	Type	Price	Notes
	Ordered with device -O = Mounted on the top -U = Mounted on the bottom	\$	Ordered separately	\$	
Control circuit Tap-off terminals					
Installed onto the upper and lower field-wiring terminals of Circuit Breakers and Molded Case Switches.					
Control Circuit	 +ST 250-NZM 7-O +ST 250-NZM 7-U	See Price List	See Price List	See Price List	2 Terminals per set. Control Circuit Wire Range: AWG 14 – 18 Cu only.
For Circuit Breakers and Molded Case Switches with bolt-on connection terminals.	+ST M8-NZM 7-O +ST M8-NZM 7-U	See Price List	See Price List	See Price List	
		See Price List	See Price List	See Price List	
Terminal Cover					
For additional protection against shock hazard. Recommended on the supply side of Circuit Breakers and Disconnect Switches. Finger proof to IEC 536					
	 +KA 250-NZM 7	See Price List	KA 250-NZM 7	See Price List	One piece cover. Fits over three terminals, top or bottom.



Ordering information:
Specify Type from column 2 or 4.
Example: + ST-250-NZM 7-U

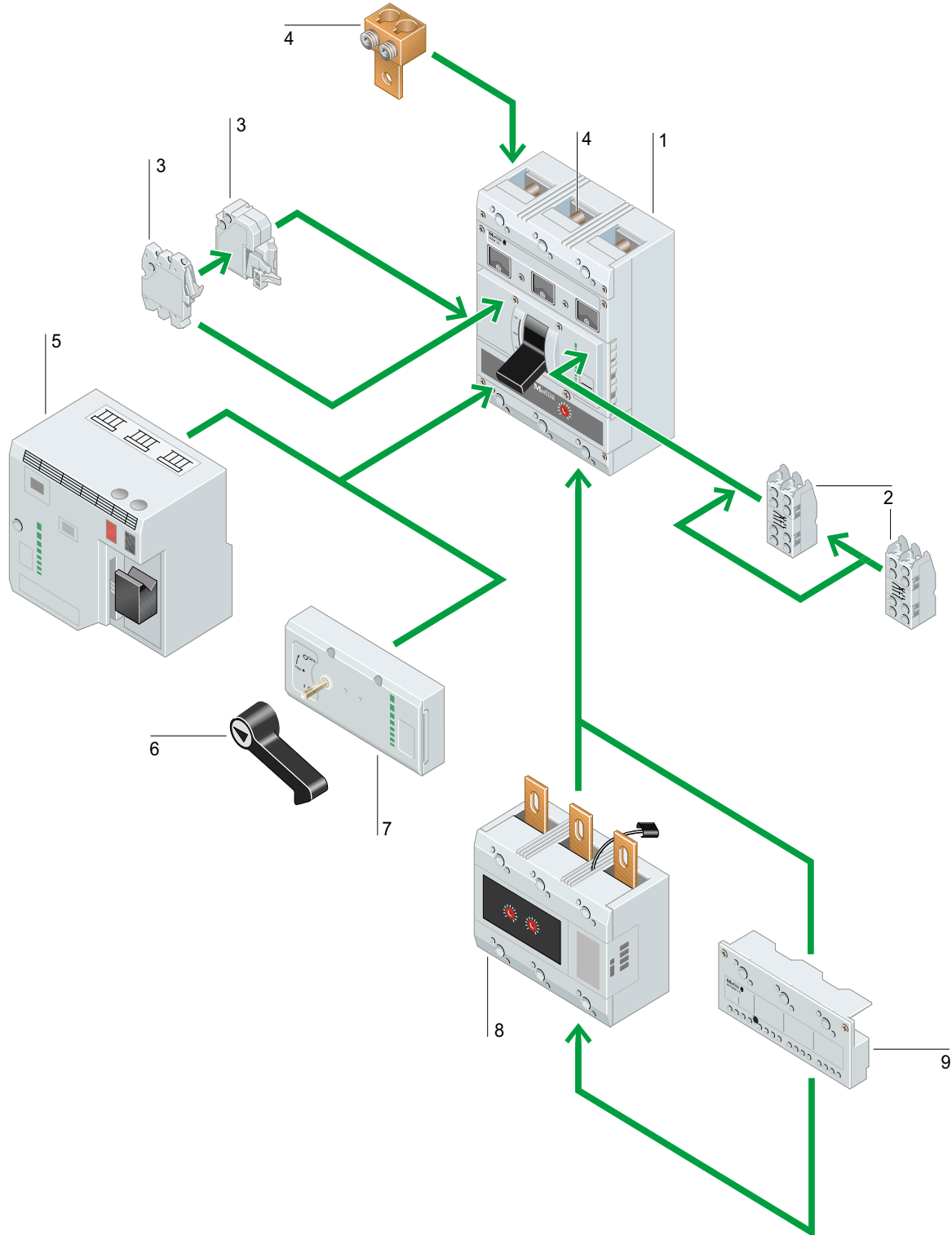

Disconnect Switches, Molded Case Switches
Circuit Breakers



NZM 10

1 Molded Case Breaker – Page 8/58 – 60

600 VAC, 600 Amp rating
Up to 100 kA @ 480 VAC Interrupting rating
Standard and fuseless current limiting versions
Solid State Trip
Field installable accessories
Supplied with terminals for cable hookup or bolt-on connection
UL Listed (UL 489), CSA certified (C 22.2 # 5.1)
Conformity with IEC/EN 60 947-2 (Circuit Breakers)

1 Molded Case Switch – Page 8/61

600 VAC, 600 Amp rating
Field installable accessories
UL Listed (UL 1087), CSA certified (C 22.2 # 5.2)
Conformity with IEC/EN 60 947-3 (Switch-Disconnectors)

2 Auxiliary Contacts – Page 8/64

Type **NHI**... standard auxiliary contact:
For signalling ON and OFF positions
Type **RHI**... trip-indicating auxiliary contact:
For signalling the Tripped (“+”) position

3 Auxiliary Contacts & Voltage Trips – Page 8/64 – 66

Type **VHI**... Early-Make auxiliary contact:
For interlocking and load shedding purposes.
To power up the undervoltage trip prior to main contact closing

Voltage Trips:

Shunt Trips

AC & DC versions

Undervoltage Trips

AC & DC versions

4 Terminal Connections – Page 8/

Pressure wire terminations for cable connection.
Bolt-on connection for crimped lug or busbar.
Terminal covers for additional protection against shock hazards.

5 Remote Control Drive – Page 8/67

Electrical operation of the circuit breaker from a remote location:
Remote ON/OFF
Remote Reset after Trip
Local manual operation possible
Padlockable OFF position

6 Rotary Handle – Page 8/68

To operate switch equipped with rotary drive mechanism.

7 Rotary Drive Mechanism – Page 8/68

Converts toggle switch operation of the switch into a rotary movement suitable for rotary style operators.
Lockable in the OFF position.

8 Ground Fault Trip Module – Page 8/67













Plugs directly into the breaker or mounts separately.
Not fed from separate power source.
Adjustable ground fault trip and time delay settings.
Automatic Reset.

9 Signalling Block – Page 8/64

Differentiated fault indication
Overload early warning signal for load shedding purposes
Local or remote signalling of breaker status
Local, remote or automatic reset.

Molded Case Circuit Breakers and Switches

Type NZM 10... Overview of Combination Options

Type	Solid State Trip Modules			Solid State Trip Modules with pick-up delay for selectivity			Auxiliary contacts (NHI...: Standard) (RHI...: Trip Indicating) (VHI...: Early-Make)			Signalling Block
										
	ZM(A)-...-NA 250 400 600	ZMV(A)-...-NA 250 400 600		ZM(A)-...-NA 250 400 600	ZMV(A)-...-NA 250 400 600		NHI- NZM 10	RHI- NZM 10	VHI-NZM 10 Not in conjunction with R-NZM 10	M- NZM 10
Molded Case Circuit Breakers										
 NZM 10-...(N)(S)/ZM(V)(A)...-NA	<input type="radio"/>	<input type="radio"/>	<input type="radio"/>	or	<input type="radio"/>	<input type="radio"/>	<input type="radio"/>	<input type="radio"/>	<input type="radio"/>	<input type="radio"/>
 NZM 10-...H/ZM(A)...-NA	<input type="radio"/>	<input type="radio"/>	<input type="radio"/>	—	—	—	<input checked="" type="radio"/>	<input checked="" type="radio"/>	<input checked="" type="radio"/>	<input checked="" type="radio"/>
Molded Case Switches										
 NZM 10-...N/B-NA	—	—	—	—	—	—	<input checked="" type="radio"/>	<input checked="" type="radio"/>	<input checked="" type="radio"/>	—
Circuit Breakers equipped with Remote Control Drive										
 NZM 10-...(N)(S)/ZM(V)(A)...-NA +R-NZM 10	<input type="radio"/>	<input type="radio"/>	<input type="radio"/>	or	<input type="radio"/>	<input type="radio"/>	<input checked="" type="radio"/>	<input checked="" type="radio"/>	—	<input checked="" type="radio"/>
 NZM 10-...H/ZM(A)...-NA + R-NZM 10	<input type="radio"/>	<input type="radio"/>	<input type="radio"/>	—	—	—	<input checked="" type="radio"/>	<input checked="" type="radio"/>	—	<input checked="" type="radio"/>
Molded Case Switches equipped with Remote Control Drive										
 NZM 10-...N/B-NA +R-NZM 10	—	—	—	—	—	—	<input checked="" type="radio"/>	<input checked="" type="radio"/>	—	—
Circuit Breaker Switch blocks without Trip Modules										
NZM 10-400N-NA	<input checked="" type="radio"/>	<input checked="" type="radio"/>	—	<input checked="" type="radio"/>	<input checked="" type="radio"/>	—	<input checked="" type="radio"/>	<input checked="" type="radio"/>	<input checked="" type="radio"/>	<input checked="" type="radio"/>
NZM 10-400S-NA	<input checked="" type="radio"/>	<input checked="" type="radio"/>	—	<input checked="" type="radio"/>	<input checked="" type="radio"/>	—	<input checked="" type="radio"/>	<input checked="" type="radio"/>	<input checked="" type="radio"/>	<input checked="" type="radio"/>
NZM 10-400H-NA	<input checked="" type="radio"/>	<input checked="" type="radio"/>	—	—	—	—	<input checked="" type="radio"/>	<input checked="" type="radio"/>	<input checked="" type="radio"/>	<input checked="" type="radio"/>
NZM 10-600N-NA	<input checked="" type="radio"/>	<input checked="" type="radio"/>	<input checked="" type="radio"/>	<input checked="" type="radio"/>	<input checked="" type="radio"/>	<input checked="" type="radio"/>	<input checked="" type="radio"/>	<input checked="" type="radio"/>	<input checked="" type="radio"/>	<input checked="" type="radio"/>
NZM 10-600S-NA	<input checked="" type="radio"/>	<input checked="" type="radio"/>	<input checked="" type="radio"/>	<input checked="" type="radio"/>	<input checked="" type="radio"/>	<input checked="" type="radio"/>	<input checked="" type="radio"/>	<input checked="" type="radio"/>	<input checked="" type="radio"/>	<input checked="" type="radio"/>
NZM 10-600H-NA	<input checked="" type="radio"/>	<input checked="" type="radio"/>	<input checked="" type="radio"/>	—	—	—	<input checked="" type="radio"/>	<input checked="" type="radio"/>	<input checked="" type="radio"/>	<input checked="" type="radio"/>

- Options for combination
- Included as standard

Disconnect Switches, Molded Case Switches
Circuit Breakers



Molded Case Circuit Breakers and Switches Type NZM 10... Overview of Combination Options

Voltage Trips

(A...: Shunt Trip)

(U...: Undervoltage Trip)

Ground-Fault Trip Drive

Remote Control Door coupling

Rotary Drive Mechanism Rotary Handle

Terminals

Bolt connection included as standard



A-NZM 10

U-NZM 10

TV-NZM 10

R-NZM 10

D-NZM 10

H 10U-NZM 10

(R)H 10-NZM 10

Bolt-on connection

Cable Terminals

●	or	●	●	●	or	●	●	or	●	●	or	●
●	or	●	●	●	or	●	●	or	●	●	or	●
●	or	●	—	●	or	●	●	or	●	●	or	●
●	or	●	●	○	—	—	—	—	—	●	or	●
●	or	●	●	○	—	—	—	—	—	●	or	●
●	or	●	—	○	—	—	—	—	—	●	or	●
●	or	●	●	or	●	or	●	or	●	●	or	●
●	or	●	●	or	●	or	●	or	●	●	or	●
●	or	●	●	or	●	or	●	or	●	●	or	●
●	or	●	●	or	●	or	●	or	●	●	or	●
●	or	●	●	or	●	or	●	or	●	●	or	●
●	or	●	●	or	●	or	●	or	●	●	or	●

1	2	3	4	5	6
	Long Time Response Current Setting (I _t) Amps	Adjustable instantaneous Pick-up Setting Amps	Adjustable Short Time Delay Pick-up setting for selectivity in networks Time delay Range: 0 – 1000 ms Amps	Type (N) Normal Level Interrupting: 42 kA @ 480 VAC	Price \$

Fixed Long Time response settings for Type NZM 10... N/ZMA...-NA

	200	400 – 2400	—	NZM 10-400 N/ZMA-200-NA	See Price List
	225	450 – 2700	—	NZM 10-400 N/ZMA-225-NA	See Price List
	250	500 – 3000	—	NZM 10-400 N/ZMA-250-NA	See Price List
	300	600 – 3600	—	NZM 10-400 N/ZMA-300-NA	See Price List
	350	700 – 4200	—	NZM 10-400 N/ZMA-350-NA	See Price List
	400	800 – 4800	—	NZM 10-400 N/ZMA-400-NA	See Price List
(600A)	500	1000 – 6000	—	NZM 10-600 N/ZMA-500-NA	See Price List
	600	1200 – 7200	—	NZM 10-600 N/ZMA-600-NA	See Price List

Adjustable Long Time response settings for Type NZM 10... N/ZM...-NA

200 – 400	400 – 4800	—	NZM 10-400 N/ZM-400-NA	See Price List
300 – 600	600 – 7200	—	NZM 10-600 N/ZM-600-NA	See Price List

Fixed Long Time response settings for Type NZM 10.../ZMVA...-NA with Short-Time Delay pick-up for Selectivity

200	1000 – 9000	2 – 12 x I _r	NZM 10-400 N/ZMVA-200-NA	See Price List
225	1000 – 9000	2 – 12 x I _r	NZM 10-400 N/ZMVA-225-NA	See Price List
250	1000 – 9000	2 – 12 x I _r	NZM 10-400 N/ZMVA-250-NA	See Price List
300	1000 – 9000	2 – 12 x I _r	NZM 10-400 N/ZMVA-300-NA	See Price List
350	1000 – 9000	2 – 12 x I _r	NZM 10-400 N/ZMVA-350-NA	See Price List
400	1000 – 9000	2 – 12 x I _r	NZM 10-400 N/ZMVA-400-NA	See Price List
500	1000 – 9000	2 – 12 x I _r	NZM 10-600 N/ZMVA-500-NA	See Price List
600	1000 – 9000	2 – 12 x I _r	NZM 10-600 N/ZMVA-600-NA	See Price List

Adjustable Long Time response settings for Type NZM 10.../ZMV...-NA with Short-Time Delay pick-up for Selectivity

200 – 400	1000 – 9000	400 – 4800	NZM 10-400 N/ZMV-400-NA	See Price List
300 – 600	1000 – 9000	600 – 7200	NZM 10-600 N/ZMV-600-NA	See Price List

Type **NZM 10... (N)(S)/ZM(A)...-NA** Molded Case Circuit Breakers are UL Listed (UL 489) and CSA Certified (22.2 Nr. 5.1) Inverse Time, Solid State Trip Circuit Breakers with a fixed or adjustable Long Time Response and adjustable instantaneous pick-up range.

Type **NZM 10... (N)(S)/ZMV(A)...-NA** are UL Listed (UL 489) and CSA Certified (22.2 Nr. 5.1) and have an additional short time delay pick-up range for selectivity in energy distribution networks. The time delay response is adjustable from 0 to 1000 milliseconds.

Type **NZM 10... H/ZM(A)...-NA** Molded Case Circuit Breakers are UL Listed (UL 489) and CSA Certified (22.2 Nr. 5.1) Current Limiting Inverse Time, Solid State Trip Circuit Breakers with a fixed or adjustable Long Time Response and adjustable instantaneous pick-up range.

Ordering Information:

State type from Column 5, 7 or 9. Example: **NZM 10-600 H/ZMA-500-NA.**

Note:

- **NZM 10** Circuit Breakers and Molded Case Switches are supplied with toggle operator. Consult page 8/68 for additional handle types.
- Consult pages 8/62 – 71 for additional accessories.
- **NZM 10** Circuit Breakers and Molded Case Switches are supplied standard with bolt-on connection. For Line and Load field-wiring terminals for cable connection, refer to page 8/70 – 71 for details on available terminals.



7		8		9		10		11	
Type	Price	Type	Price	Type	Price	Type	Price	Type	Price
(S) Super Level Interrupting: 65 kA @ 480 VAC	\$	(H) Highest Level Interrupting: Fuseless Current Limiting Circuit Breaker 100 kA @ 480 VAC	\$						
NZM 10-400 S/ZMA-200-NA	See Price List	NZM 10-400 H/ZMA-200-NA	See Price List						
NZM 10-400 S/ZMA-225-NA	See Price List	NZM 10-400 H/ZMA-225-NA	See Price List						
NZM 10-400 S/ZMA-250-NA	See Price List	NZM 10-400 H/ZMA-250-NA	See Price List						
NZM 10-400 S/ZMA-300-NA	See Price List	NZM 10-400 H/ZMA-300-NA	See Price List						
NZM 10-400 S/ZMA-350-NA	See Price List	NZM 10-400 H/ZMA-350-NA	See Price List						
NZM 10-400 S/ZMA-400-NA	See Price List	NZM 10-400 H/ZMA-400-NA	See Price List						
NZM 10-600 S/ZMA-500-NA	See Price List	NZM 10-600 H/ZMA-500-NA	See Price List						
NZM 10-600 S/ZMA-600-NA	See Price List	NZM 10-600 H/ZMA-600-NA	See Price List						
NZM 10-400 S/ZM-400-NA	See Price List	NZM 10-400 H/ZM-400-NA	See Price List						
NZM 10-600 S/ZM-600-NA	See Price List	NZM 10-600 H/ZM-600-NA	See Price List						
NZM 10-400 S/ZMVA-200-NA	See Price List	—	—						
NZM 10-400 S/ZMVA-225-NA	See Price List	—	—						
NZM 10-400 S/ZMVA-250-NA	See Price List	—	—						
NZM 10-400 S/ZMVA-300-NA	See Price List	—	—						
NZM 10-400 S/ZMVA-350-NA	See Price List	—	—						
NZM 10-400 S/ZMVA-400-NA	See Price List	—	—						
NZM 10-600 S/ZMVA-500-NA	See Price List	—	—						
NZM 10-600 S/ZMVA-600-NA	See Price List	—	—						
NZM 10-400 S/ZMV-400-NA	See Price List	—	—						
NZM 10-600 S/ZMV-600-NA	See Price List	—	—						

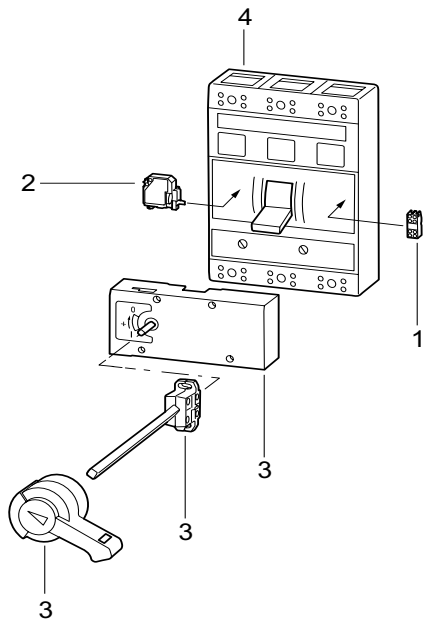

Accessories	Page
1 Auxiliary contacts	8/64
2 Voltage Trips	8/65, 66
3 Handles and operators	8/69
4 Terminals	8/71

UL/CSA Interrupting ratings (AC, 60Hz)

Type	RMS Sym kAmps @		
	240 V	480 V	600 V
NZM 10-... N/ ZM(V)(A)-...-NA	65	42	35
NZM 10-... S/ ZM(V)(A)-...-NA	100	65	42
NZM 10-... H/ ZM(A)-...-NA	200	100	50

Features of ZMV(A)...Trip Modules used for Selectivity:

Fixed (ZMVA...) or adjustable (ZMV...) long time response current. Adjustable time delay (2 – 20 sec.) for current levels at 6 x the long time response current (I_r). Long time response current can be disconnected. Adjustable time delay (0 – 1000 ms) pick-up setting. Adjustable instantaneous pick-up response.

Circuit Breakers
Disconnect Switches, Molded Case Switches

Molded Case Circuit Breakers - Instantaneous Trip type, 600 Amp NZM 10-.../ZM-...-OBI...-CNA

1	2	3	4	5
Frame Rating	Continuous Current Rating	Adjustable Instantaneous Trip Response Range	Type	Price
	Amps	Amps		\$
Solid State Instantaneous Trip Circuit Breakers 600 V AC, UL/CSA (N) Normal Level Short circuit Rating				
	400	800...4800	NZM 10-400 N/ZM -400-OBI-CNA	See Price List
	600	1200...7200	NZM 10-600 N/ZM -600-OBI-CNA	See Price List
NZM 10-...N/ZM-...-OBI-CNA (600 Amps)				See Price List
Solid State Instantaneous Trip Circuit Breakers 600 V AC, UL/CSA (H) High Level Short circuit Rating				
	400	800...4800	NZM 10-400 H/ZM -400-OBI-CNA	See Price List
	600	1200...7200	NZM 10-600 H/ZM -600-OBI-CNA	See Price List
NZM 10-...N/ZM-...-OBI-CNA (600 Amps)				See Price List

Type **NZM10-...N/ZM-...-OBI...-CNA** and **NZM10-...H/ZM-...-OBI...-CNA** Molded Case Circuit Breakers are UL Recognized (UL 489) and CSA Certified (22.2 Nr. 5.1) Instantaneous Trip type Circuit Breakers with an adjustable instantaneous trip function. Per NEC, they provide motor short circuit protection as part of a listed combination motor controller that includes coordinated motor overload protection. Short circuit interrupting ratings are, therefore, established and valid only for the listed combination motor controller assembly and associated housing or enclosure.

The **NZM 10...H** instantaneous trip circuit breaker features a current limiting design contact assembly and can provide high fault short circuit current ratings for motor starters of up to 65kA @ 480VAC.

Consult Moeller Electric for Combination Motor Controller high fault short circuit ratings as Motor Control Center unit starters featuring Type **NZM10...N** and **NZM10...H** Instantaneous Trip Circuit Breakers.

Ordering Information:

State type from Column 4. Example: **NZM 10-600 H/ZM-600-OBI-CNA**

Note:

- **NZM 10** Circuit Breakers and Molded Case Switches are supplied with toggle operator. Consult page 8/69 for additional handle types.
- Consult page 8/67 for additional accessories.
- **NZM 10** Circuit Breakers and Molded Case Switches are supplied standard with bolt-on connection. For Line and Load field-wiring terminals for cable connection, refer to page 8/71 for details on available terminals.



1	2	3	4	5
	Ampere Rating	Type	Price	Notes
	Amps		\$	
Molded Case Switches With provisions for bolt-on connection				
	400	NZM 10-400 N/B-NA	See Price List	UL/CSA Short Circuit Current Rating: 25 kA RMS Sym @ 600 VAC
	600	NZM 10-600 N/B-NA	See Price List	
			See Price List	
			See Price List	
			See Price List	
			See Price List	

Type **NZM 10...N/B-NA** Molded Case Switches are virtually identical in construction to **NZM 10** Molded Case Circuit Breakers except that they are manual, non-automatic switches without any overload or overcurrent protective features. They are equally rated up to 600 Amps. All Molded Case Switches are UL Listed (UL 1087)/ CSA certified (C 22.2 Nr. 5.2), in conformity with IEC/EN 60 947-3 (Switch-Disconnectors) and CE marked.

Molded Case Switches are tested to determine their acceptability for continuous operation at their marked rated load. In addition, they are tested at six times their full ampere rating to cover motor circuit applications and are suitable for use as motor circuit disconnects per Section 430-109 of the National Electrical Code.

Accessories such as voltage trips, auxiliary contacts, rotary handles etc. are common to all NZM 10 circuit breakers and molded case switches and are UL listed and CSA certified for field installation.

Ordering Information:
Specify Type from Column 3. Example: **NZM 10-400 N/B-NA**.

- Note:
- **NZM 10** Circuit Breakers and Molded Case Switches are supplied with toggle operator. Consult page 8/69 for additional handle types.
 - Consult page 8/67 for additional accessories.
 - **NZM 10** Circuit Breakers and Molded Case Switches are supplied standard with bolt-on connection. For Line and Load field-wiring terminals for cable connection, refer to page 8/71 for details on available terminals.

Inverse Time Circuit Breaker Components, 600 Amps, 600VAC Type NZM 10...-NA Switch Blocks, Solid State Trip Modules

UL/CSA, IEC/EN 60 947-2, CE

1	2	3	4	5	6
<p>The NZM 10 Inverse Time Molded Case Breaker is made up of a Switch Block and a protective Trip Module. Switch Blocks and Trip Modules can be ordered separately and combined per the charts and columns shown here to suit any particular application. Refer to chart at bottom of page for resultant interrupting ratings.</p>	Switch Block Ratings	Trip Module Ratings			<p>Compatibility of Switch Block with Trip Module</p> <p>Dots (●) in each row indicate which Trip Module (Refer to column 7) can be used with the Switch Block type shown below. Dashes (—) indicate incompatibility.</p>
	Continuous Current (I_u)	Long Time Response Current Setting (I_t)	Adjustable instantaneous Pick-up Setting	Adjustable Short Time Delay Pick-up setting for selectivity in networks	
	Amps	Amps	Amps	Amps	NZM10-400... NZM10-600...

Switch Blocks, Suitable for insertion of Trip Modules



400
400
400
600
600
600

Solid State Trip Modules



Fixed Long Time Response	200	400 – 2400	—	●	●	
	225	450 – 2700	—	●	●	
	250	500 – 3000	—	●	●	
	300	600 – 3600	—	●	●	
	350	700 – 4200	—	●	●	
	400	800 – 4800	—	●	●	
	500	1000 – 6000	—	—	●	
	600	1200 – 7200	—	—	●	
	Adjustable Long Time Response	200 – 400	400 – 4800	—	●	●
		300 – 600	600 – 7200	—	—	●

Solid State Trip Modules for Selectivity in networks



Fixed Long Time Response	200	1000 – 9000	2 – 12 x I_t	●	●
	225	1000 – 9000	2 – 12 x I_t	●	●
	250	1000 – 9000	2 – 12 x I_t	●	●
	300	1000 – 9000	2 – 12 x I_t	●	●
	350	1000 – 9000	2 – 12 x I_t	●	●
	400	1000 – 9000	2 – 12 x I_t	●	●
	500	1000 – 9000	2 – 12 x I_t	—	●
	600	1000 – 9000	2 – 12 x I_t	—	●
Adjustable Long Time Response	200...400	1000...9000	400...4800	●	●
	300...600	1000...9000	600...7200	—	●

UL/CSA Interrupting ratings (AC, 60Hz)

Type	RMS Sym kA @		
	240 V	480 V	600 V
NZM 10-... N/ ZM(V)(A)-...-NA	65	42	35
NZM 10-... S/ ZM(V)(A)-...-NA	100	65	42
NZM 10-... H/ ZM(A)-...-NA	200	100	50

Type **NZM 10...** Molded Case Circuit Breakers can be ordered complete (consult p. 8/58,59), or assembled from components by combining Switch Blocks and protective Trip Modules.
Example: **NZM10-600N-NA (Switch Block) +ZMA-500-NZM 10-NA (Trip Module) = NZM 10-600 N/ZMA-500-NA Molded Case Circuit Breaker**

Disconnect Switches, Molded Case Switches
Circuit Breakers

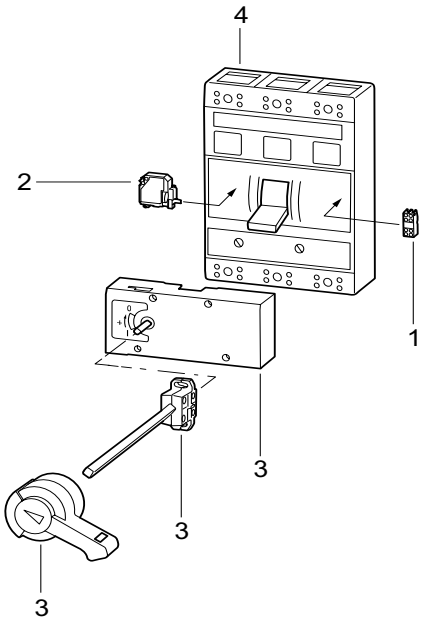

7 Type	8 Price	9 Notes	10										
NZM 10-400N-NA NZM 10-400S-NA NZM 10-400H-NA NZM 10-600N-NA NZM 10-600S-NA NZM 10-600H-NA	\$ See Price List See Price List See Price List See Price List See Price List See Price List	<p>NZM 10 Switch Blocks make up a complete breaker minus the protective Trip Module. Add a Trip Module from below to complete the breaker assembly. Refer to Column 6 for compatibility information on Switch Blocks and Trip Modules. Refer to chart at bottom of opposite page for resultant circuit breaker interrupting ratings.</p>											
ZMA-200-NZM 10-NA ZMA-225-NZM 10-NA ZMA-250-NZM 10-NA ZMA-300-NZM 10-NA ZMA-350-NZM 10-NA ZMA-400-NZM 10-NA ZMA-500-NZM 10-NA ZMA-600-NZM 10-NA	See Price List See Price List See Price List See Price List See Price List See Price List See Price List	<p>ZMA solid state trip modules have a fixed long time response and an adjustable instantaneous pick-up range.</p>											
ZM-400-NZM 10-NA ZM-600-NZM 10-NA	See Price List See Price List	<p>ZM solid state trip modules have an adjustable long time response and an adjustable instantaneous pick-up range.</p>	<table border="1"> <thead> <tr> <th data-bbox="1031 1102 1169 1134">Accessories</th> <th data-bbox="1404 1102 1469 1134">Page</th> </tr> </thead> <tbody> <tr> <td data-bbox="1031 1155 1258 1186">1 Auxiliary contacts</td> <td data-bbox="1404 1155 1453 1186">8/64</td> </tr> <tr> <td data-bbox="1031 1186 1209 1218">2 Voltage Trips</td> <td data-bbox="1404 1186 1485 1218">8/65, 66</td> </tr> <tr> <td data-bbox="1031 1218 1307 1249">3 Handles and operators</td> <td data-bbox="1404 1218 1453 1249">8/69</td> </tr> <tr> <td data-bbox="1031 1249 1177 1281">4 Terminals</td> <td data-bbox="1404 1249 1453 1281">8/71</td> </tr> </tbody> </table>	Accessories	Page	1 Auxiliary contacts	8/64	2 Voltage Trips	8/65, 66	3 Handles and operators	8/69	4 Terminals	8/71
Accessories	Page												
1 Auxiliary contacts	8/64												
2 Voltage Trips	8/65, 66												
3 Handles and operators	8/69												
4 Terminals	8/71												
ZMVA-200-NZM 10-NA ZMVA-225-NZM 10-NA ZMVA-250-NZM 10-NA ZMVA-300-NZM 10-NA ZMVA-350-NZM 10-NA ZMVA-400-NZM 10-NA ZMVA-500-NZM 10-NA ZMVA-600-NZM 10-NA ZMV-400-NZM 10-NA ZMV-600-NZM 10-NA	See Price List See Price List See Price List See Price List See Price List See Price List See Price List See Price List See Price List See Price List	<p>Features of ZMV(A)... Trip Modules used for Selectivity: Fixed (ZMVA...) or adjustable (ZMV...) long time response current. Adjustable time delay (2 – 20 sec.) for current levels at 6 x the long time response current (I_r). Long time response current can be disconnected. Adjustable time delay (0 – 1000 ms) pick-up setting. Adjustable instantaneous pick-up response.</p> <p>Note: ZMVA... and ZMV Trip Modules cannot be combined with NZM 10-400 H-NA and NZM 10-600 H-NA Switch Blocks.</p>											







Ordering Information: Specify Type from column 7. Example: **NZM 10-600 N-NA**

- Note:
- Compatible Trip Modules will easily fit into the front part of the switch block. Incompatible Trip Modules and Switch Block combinations are mechanically blocked to prevent creation of improper combinations. (Refer to columns 6 & 7)
 - **NZM 10** Switch Blocks are supplied with toggle operator. Consult page 8/69 for additional handle types.
 - Consult page 8/67 for additional accessories.
 - **NZM 10** Circuit Breakers and Molded Case Switches are supplied standard with bolt-on connection. For Line and Load field-wiring terminals for cable connection, refer to page 8/71 for details on available terminals.

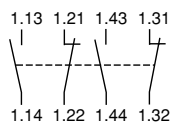

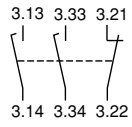
Molded Case Circuit Breakers and Switches

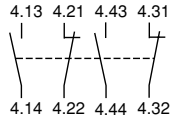
Auxiliary Contacts, Signalling Unit for Type NZM 10...-NA

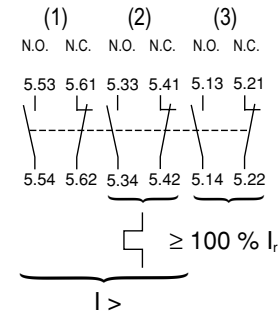
1	2	3	4
	Contact sequence	Type	Price
			\$
<p>Auxiliary Contacts NHI standard auxiliary contacts Switching simultaneously with the main contacts. They can be typically used for signalling, interlocking or switching auxiliary circuits such as a control circuit.</p> 		NHI-NZM 10	See Price List See Price List See Price List
<p>VHI Early-Make auxiliary contacts Typically used for powering up the undervoltage trip prior to closing of main contacts and for control circuit interlocking tasks. Cannot be used in conjunction with R-NZM 10 Remote Control Drive</p> 		VHI-NZM 10	See Price List See Price List See Price List
<p>RHI trip-indicating auxiliary contacts Actuating independently of the normal ON and OFF operations of the device, switching only when the device has tripped due to overcurrents or other tripping causes such as those initiated by voltage trips.</p> 		RHI-NZM 10	See Price List See Price List See Price List
<p>Signalling Block Differential fault indication and visual display of breaker operating states</p> <p>(1) Tripping due to short-circuit. (2) Tripping due to overload and general trip condition. (3) Overload early warning signal in the event that the long time response setting is about to be exceeded (i.e. useful for load shedding purposes)</p> <p>Each function signals via a pair of contacts (1 N.O. & 1 N.C.)</p> <p>Mounts directly onto lower portion of circuit-breaker Supply voltage necessary: 24 – 230 V, AC or DC</p> 		M-NZM 10	See Price List See Price List See Price List See Price List See Price List See Price List

Auxiliary Contacts and Signalling Blocks are field installable.

Ordering information:
 Specify Type from column 3.
 Example: **NHI-NZM 10**

If ordering with device, just specify a "+" in front of the Type number. Example: **+ NHI-NZM 10**

Disconnect Switches, Molded Case Switches

Circuit Breakers



Molded Case Circuit Breakers and Switches Shunt Trips for Type NZM 10...-NA

1	2	3	4	5
	Rated Actuating Voltage (U _s)	Type	Price \$ each	
<p>Shunt Trips Shunt Trips are typically used to electrically trip the device from a remote location. The A...- NZM 10 series is rated for 100% continuous duty. Shunt Trips cannot be mounted together with Undervoltage Trips.</p> 	AC/DC	A-NZM 10 (24V)	See Price List	See Price List
	24	A-NZM 10 (48V)	See Price List	See Price List
	48	A-NZM 10 (60V)	See Price List	See Price List
	60	A-NZM 10 (110-120V)	See Price List	See Price List
	110 – 120	A-NZM 10 (125-130V)	See Price List	See Price List
	125 – 130	A-NZM 10 (208-215V)	See Price List	See Price List
	208 – 215	A-NZM 10 (220-240V)	See Price List	See Price List
	220 – 240	A-NZM 10 (380-415V)	See Price List	See Price List
	380 – 415	A-NZM 10 (440-480V)	See Price List	See Price List
	440 – 480	A-NZM 10 (500V)	See Price List	See Price List
	500	A-NZM 10 (600V)	See Price List	See Price List
600				





Field installable and suitable for mounting into **NZM 10** Molded Case Circuit Breakers and Switches. Shunt Trips are rated for both AC and DC voltages and can accommodate a frequency range between 0 and 400 Hz.

Shunt trips are field installable.

Ordering information:
Specify Type from column 3.
Example: **A-NZM 10 (110-120V)**

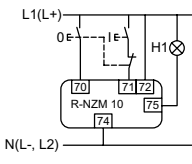
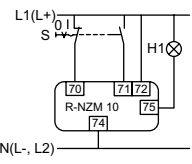
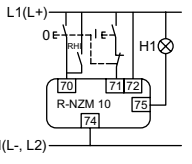
If ordering with device, just specify a “+” in front of the Type number.
Example: **+ A-NZM 10 (110-120V)**







Type NZM 10...-NA Molded Case Circuit Breakers and Switches Remote Control Drives and Accessories

1	2	3	4	5
	Contact diagram	Rated Actuating Voltage (U _s) 50/60 Hz	Type	Price
Remote Control Drive For both Circuit Breakers and Molded Case Switches Switching times: ON 60 ms, OFF 30 ms Manual switching possible				
				
	 3-wire control			
	 2-wire control			
	 3-wire control with automatic reset to the OFF position after the switch has tripped.			
Mounts on top of NZM 10 Circuit Breakers and Molded Case Switches		110 – 120 AC 220 – 240 AC 380 – 415 AC 24 DC 48 – 60 DC 100 – 130 DC 220 – 240 DC	R-NZM 10 (110-120V AC) R-NZM 10 (220-240V AC) R-NZM 10 (380-415V AC) R-NZM 10 (24V DC) R-NZM 10 (48-60V DC) R-NZM 10 (100-130V DC) R-NZM 10 (220-240V DC)	\$ See Price List See Price List See Price List See Price List See Price List See Price List See Price List See Price List See Price List See Price List
Pushbutton operator For manual ON-OFF switching of encapsulated NZM 10 breakers and switches equipped with a remote control drive. Not for use in conjunction with KVR2-NZM 10 mechanical interlock.				
		Mounting depth 250 – 285 mm Mounting depth 285 – 400 mm	MD-NZM 10 MDV-NZM 10	
IP 54 Protective cover for door cutout area Transparent cover to provide a panel cutout area with IP 54 protection For use where the Remote Control Drive protrudes from the cutout area of the enclosure door.				
			RTR-NZM 10	
Sealing plate To block off manual switching access of the remote control drive at the device. Electrical switching from a remote location and manual tripping of the circuit breaker (push to trip feature) are not affected.				
			PL-NZM 10	

 Circuit Breakers
Disconnect Switches, Molded Case Switches

Ordering information: Specify Type from column 4. Example: **R-NZM 10 (110-120V AC)**
 If ordering with device, just specify a "+" in front of the Type number.
 Example: **+ R-NZM 10 (110-120V AC)**

Molded Case Circuit Breakers and Switches Accessories for Type NZM 10...-NA



1	2	3	4
	Type	Price	Notes
		€	
<p>Toggle switch interlock</p> 	SVB-NZM 10	See Price List	Permits the OFF position of the toggle operator to be locked with up to 3 padlocks (hasp thickness 6 – 8 mm)
<p>Insulating cutout frame</p> 	RT-NZM 10	See Price List	For use where the toggle switch protrudes from the enclosure. Provides degree of protection IP 40. Affixed from the rear with screws. Can be inscribed.
<p>Rotary Drive Mechanism</p> 	D-NZM 10	See Price List	Converts ON and OFF switching from a vertical toggle movement to a rotary motion. Required for the use of rotary and door coupling/interlocking rotary handles. Can be locked in the OFF position with up to 3 padlocks. Hasp thickness, 4 – 8 mm.
<p>Rotary Handle, for open or panel mounted devices</p> 	H10U-SW	See Price List	Black color. Suitable for open mount switches. No door interlocking or padlocking provisions. Requires Rotary Drive mechanism.
<p>Extension shaft</p>  <p>For mounting depths 175 – 400 mm</p> <p>For mounting depths 260 – 600 mm</p>	<p>A-NZM 10</p> <p>A600-NZM 10</p>	<p>See Price List</p> <p>See Price List</p>	Can be cut to required length.
<p>Maintenance Handle</p> <p>To actuate the device when the panel door is open.</p>  <p>For Type A-NZM 10 Extension shafts</p> <p>For Type A600-NZM 10 Extension shafts</p>	<p>H10UZ</p> <p>H12UZ</p>	<p>See Price List</p> <p>See Price List</p>	For panel mounted switches Push-fits onto the extension shaft

Ordering information:
Specify Type from column 2. Example: **D-NZM 10**

If ordering with device, just specify a “+” in front of the Type number.
Example: **+ D-NZM 10**





Molded Case Circuit Breakers and Switches Type NZM 10...-NA Accessories

1	2	3	4																				
		Type	Price																				
			\$																				
<p>Handle for Cover/Door Interlocking Degree of protection UL/NEMA 3R/12; IEC IP 55 With cover interlocking and padlocking feature Rotary Drive Mechanism required. Can be locked in the OFF or ON position with up to 3 padlocks 3 distinct Handle positions: OFF- +(tripped)- ON</p> <p>Black color: For standard Main Disconnect Switch applications</p> 		H 10-SW-NA	See Price List																				
<p>Red-yellow color: Enables the switch to be used as the Emergency-Stop Disconnect</p> 		RH 10-NA	See Price List																				
<p>Switch position indicator Indicates position of switch (OFF, tripped or ON) when panel door is open.</p>		SA-NZM 10	See Price List																				
<p>Main Disconnect Switch Assembly Kits for CE marked control panels per IEC/EN 60 204-1 Type NZM 10...-NA breakers and switches have dual UL/CSA and IEC/EN ratings. They are suitable for use as Main Disconnect Switches in control panels that must be CE marked and designed to comply with the Machinery Directive standard EN 60 204-1. Kit includes:</p> <ul style="list-style-type: none"> • Door interlocking rotary handle, color Black • Rotary Drive Mechanism • Extension shaft for 400 mm mounting depth • External warning plate • Black lightning symbol <p>Same as above, but with red-yellow door interlocking rotary handle. For use when Main Disconnect also fulfills Emergency-Stop function per IEC/EN 60204-1</p>		V-NZM 10-SW	See Price List																				
		V-NZM 10	See Price List																				
<p>Main Disconnect Warning plates English Inscription: "Main Switch – Open only in OFF position" Warning plates also available in other languages:</p> <table border="0"> <tr> <td>61 German</td> <td>67 Dutch</td> <td>72 Portuguese</td> <td>77 Spanish</td> </tr> <tr> <td>63 French</td> <td>68 Italian</td> <td>73 Romanian</td> <td>78 Czech</td> </tr> <tr> <td>64 Bulgarian</td> <td>69 Greek</td> <td>74 Russian</td> <td>79 Turkish</td> </tr> <tr> <td>65 Danish</td> <td>70 Norwegian</td> <td>75 Swedish</td> <td>80 Hungarian</td> </tr> <tr> <td>66 Finnish</td> <td>71 Polish</td> <td>76 Serbo-Croatia</td> <td>81 Afrikaans</td> </tr> </table> <p>To obtain warning plates in other languages, insert the language code number into the type reference. Example: External warning plate in Spanish would be: ZS 77-NZM 10</p> <p>Blank plate (for engraving or printing)</p>		61 German	67 Dutch	72 Portuguese	77 Spanish	63 French	68 Italian	73 Romanian	78 Czech	64 Bulgarian	69 Greek	74 Russian	79 Turkish	65 Danish	70 Norwegian	75 Swedish	80 Hungarian	66 Finnish	71 Polish	76 Serbo-Croatia	81 Afrikaans	ZS 62-NZM 10	See Price List
61 German	67 Dutch	72 Portuguese	77 Spanish																				
63 French	68 Italian	73 Romanian	78 Czech																				
64 Bulgarian	69 Greek	74 Russian	79 Turkish																				
65 Danish	70 Norwegian	75 Swedish	80 Hungarian																				
66 Finnish	71 Polish	76 Serbo-Croatia	81 Afrikaans																				
		ZS..-NZM 10	See Price List																				
		ZS 60-NZM 10	See Price List																				

Ordering information:
 Specify Type from column 3.
 Example: **H 10-SW-NA**

If ordering with device, just specify a "+" in front of the Type number.
 Example: **+ H 10-SW-NA**

Molded Case Circuit Breakers and Switches Accessories for Type NZM 10...-NA

1	2	3 Type	4 Price
Mechanical interlocks			See Price List
For mechanically interlocking two NZM 10 Circuit Breakers or Molded Case Switches mounted in a panel.			See Price List
Fits toggle operators or rotary drive mechanisms			See Price List
For two circuit breakers			See Price List
For two circuit-breakers equipped with R-NZM 10 Remote Control Drives. (R-NZM 10 must be electrically interlocked at the same time)			See Price List
			KV2-NZM 10 KVR2-NZM 10
For mechanically interlocking three NZM 10 Circuit Breakers or Molded Case Switches mounted in a panel.			See Price List
Fits toggle operators or rotary drive mechanisms			See Price List
			KV3-NZM 10
For emergency power supplies: Mechanically interlocking two incoming supply circuit breakers with one emergency supply breaker. Fits toggle operators or rotary drive mechanisms.			See Price List
Possible switching positions:			See Price List
Incomer 1	Emergency	Incomer 2	See Price List
0	0	0	See Price List
1	V	0	See Price List
1	V	1	See Price List
0	V	1	See Price List
V	1	V	See Price List
0 = OFF V = Interlocked 1 = ON			See Price List
KVA3-NZM 10			See Price List







Disconnect Switches, Molded Case Switches

Circuit Breakers



Ordering information:
Specify Type from column 3.
Example: **KV2-NZM 10**

Molded Case Circuit Breakers and Switches Terminals for Type NZM 10...-NA

1	2	3	4	5	6	7
General info	Maximum Rated Current Amps	Conductor Cross-section Range and Material	Type suffix ¹⁾ Sets of three terminals ordered with breaker or molded case switch: O = Mounted on Top U = Mounted on Bottom	Price \$	Type Individual terminals supplied separately for field mounting	Price \$
Terminals						
Supplied with 3 terminal covers (Type H-NZM 10) and an insulating plate onto which the circuit breaker is mounted.		600	2 x AWG 2 – 500 kcmil Cu/Al	+ K2X240IP-NZM 10-O + K2X240IP-NZM 10-U	See Price List	See Price List
Supplied with 1 terminal cover (Type H-NZM 10) and an insulating plate onto which the circuit breaker is mounted.		600	2 x AWG 2 – 500 kcmil Cu/Al	—	See Price List	K2X240IP-NZM 10 ²⁾
Supplied with 1 terminal cover (Type H-NZM 10)		600	2 x AWG 2 – 500 kcmil Cu/Al	—	See Price List	K2X240-NZM 10 ²⁾
Single cable clamp terminal. Not supplied with terminal cover. Suitable terminal cover is Type HH-NZM 10		350	250 – 500 kcmil Cu only	+ K300-NZM 10-O + K300-NZM 10-U	See Price List	K300-NZM 10
Double cable clamp terminal. Not supplied with cover. Suitable terminal cover is Type HH-NZM 10		500	2 x AWG 3/0 – 250 kcmil Cu only	+K2x120-NZM 10-O +K2x120-NZM 10-U	See Price List	K2x120-NZM 10
Terminal Covers						
Single pole terminal cover. Supplied standard with Type K2x240(IP) terminals. Can be used for bolt-on or cable lug connection.				+H-NZM 10-O +H-NZM 10-U	See Price List	H-NZM 10
One piece, 3 pole terminal cover. Suitable for use with Type K300 or K2x120 terminals.				+HH-NZM 10-O +HH-NZM 10-U	See Price List	HH-NZM 10

NZM 10 Circuit Breakers and Molded Case Switches are supplied standard with bolt-on connection. For Line and Load field-wiring terminals for cable connection, select from information specified above. All terminals can be ordered factory installed with the device (Column 4) or separately for field installation (Column 6).

Ordering information:
Specify Type from Columns 4 or 6. Example: **+ K2 x 240IP-NZM 10-O**

- When ordering with the device (Column 4), the Type suffix specifies which side should be equipped with terminals:
Suffix **O** - Denotes a set of three terminals and covers mounted on the top.
Suffix **U** - Denotes a set of three terminals and covers mounted on the bottom.
Note: All Moeller Electric Molded Case Circuit Breakers, including the **NZM 10**, are UL listed and CSA certified for reverse feed connection and can therefore be fed optionally from top or bottom.
- Complete set of three (for top or bottom) Type **K2x240(IP)** terminals for field installation (column 6) consists of the following:
 - Qty. of one **K2x240IP** terminal, which is supplied with one **H-NZM 10** terminal cover and one insulating plate.
 - Qty. of two **K2x240** terminals, which are supplied each with one **H-NZM 10** terminal cover.

Circuit-Breakers, NZM... 4, 6, 9, 12

Tripping Characteristics

Tripping characteristics

The tripping characteristics show the tripping time of the breakers in relation to the response current. The mean values of the tolerance bands are indicated at an ambient temperature of 20°C, starting from cold. The tripping time of overload releases at operational temperature reduces to approximately 1/4 of that shown.

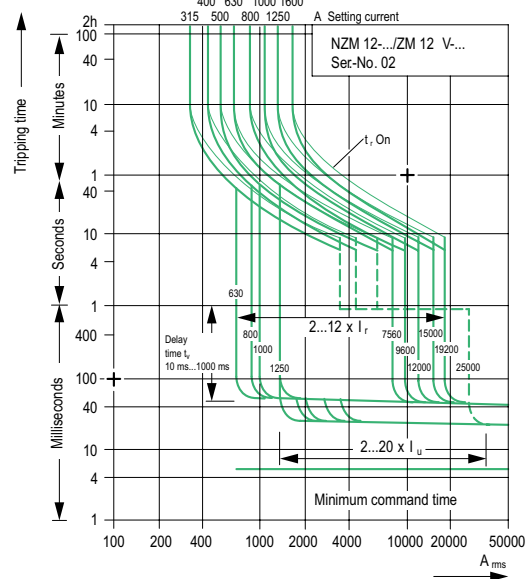
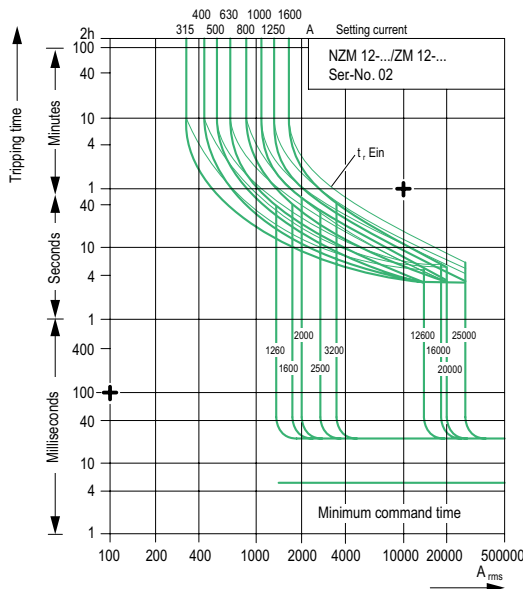
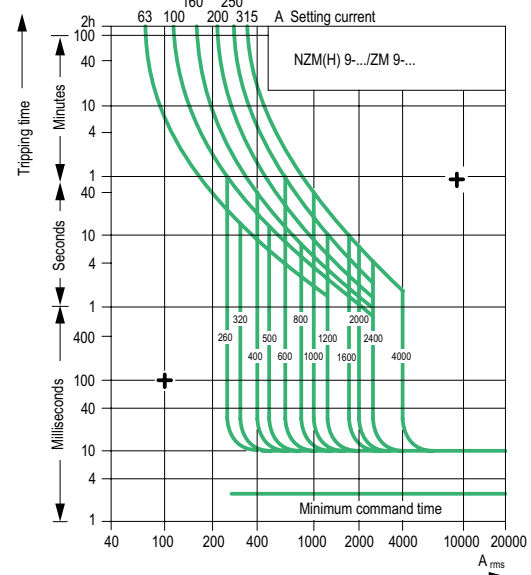
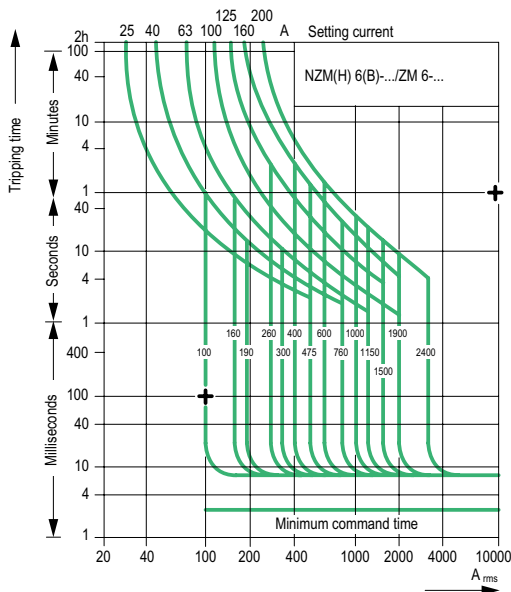
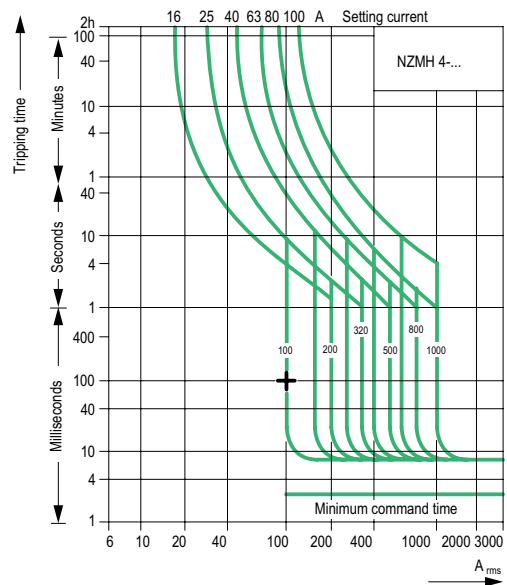

Let-through current \hat{I}_D

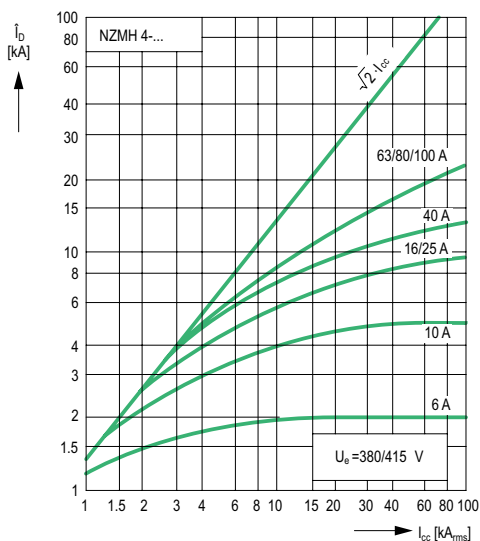

Let-through energy I^2t

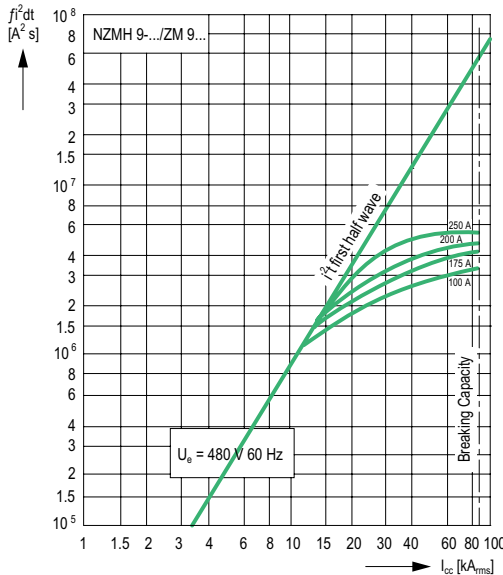
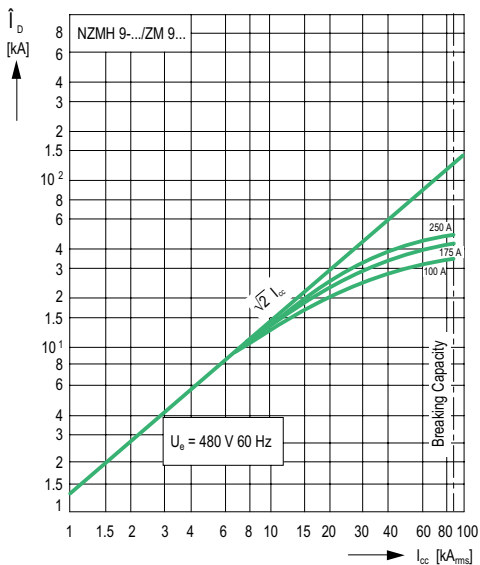
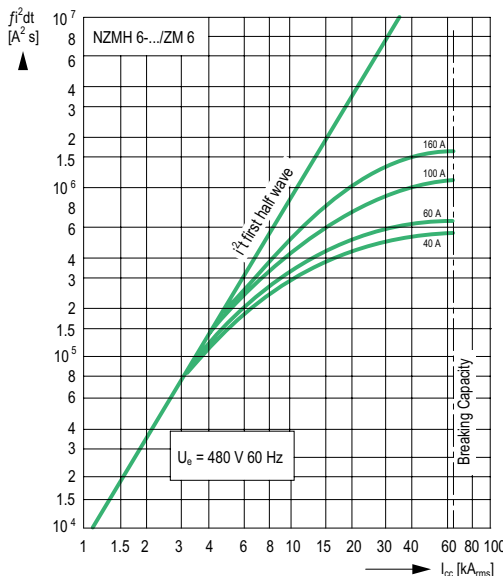
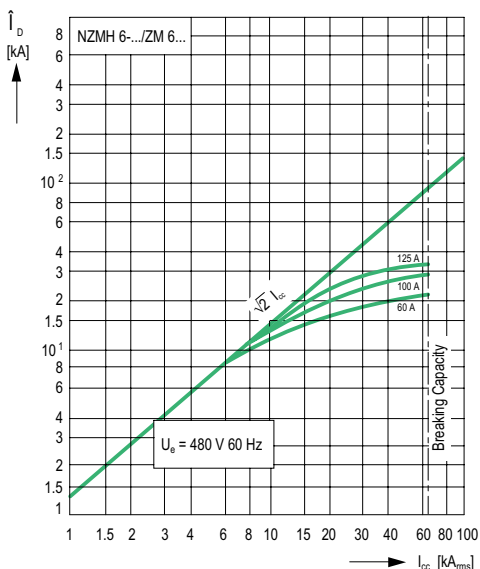
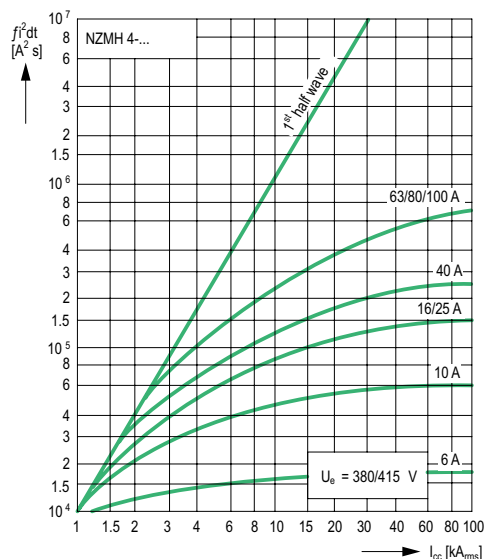

Circuit-Breakers, NZM 7

Tripping Characteristics, Let-Through Characteristics

Tripping characteristics, System protection

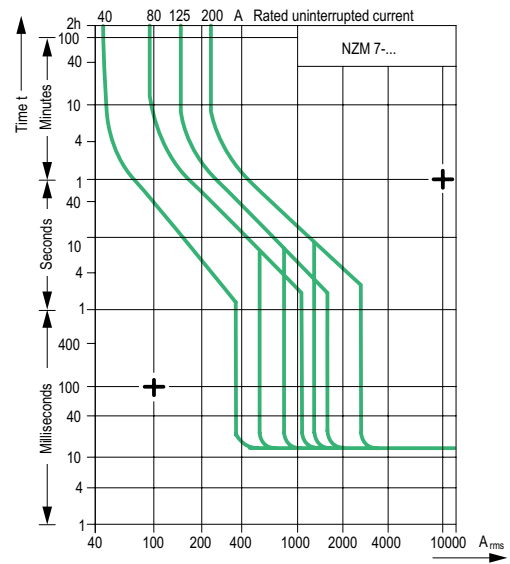
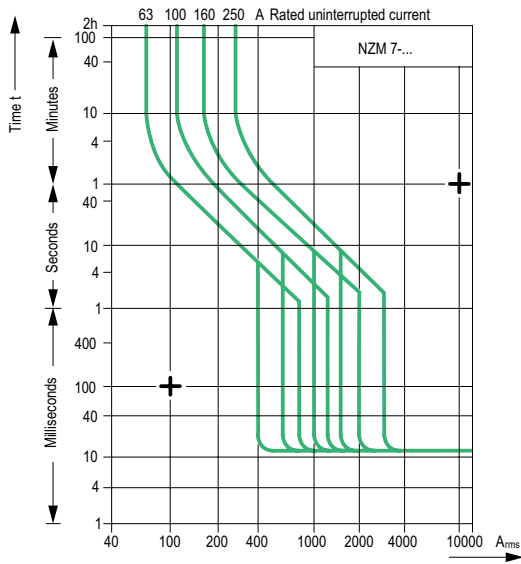

Let-through current \hat{I}_D

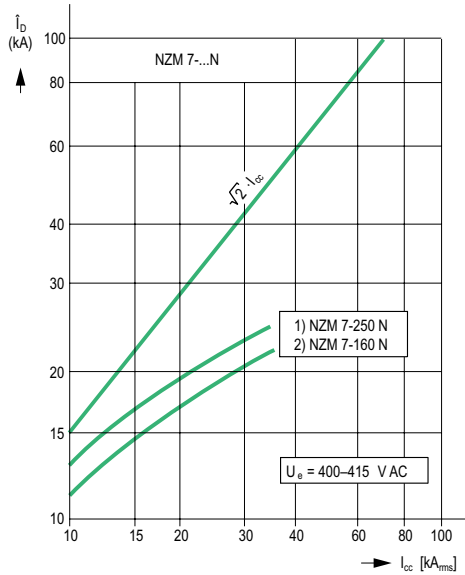

Let-through energy I^2t

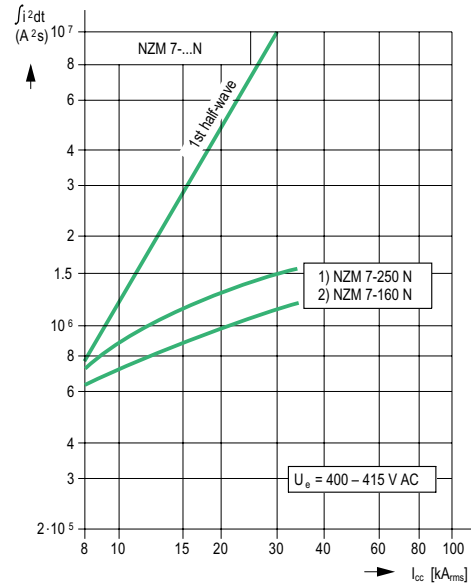

Inverse time and Instantaneous response

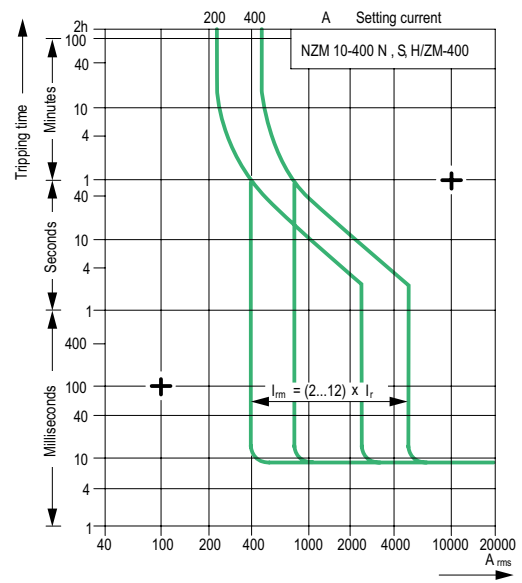
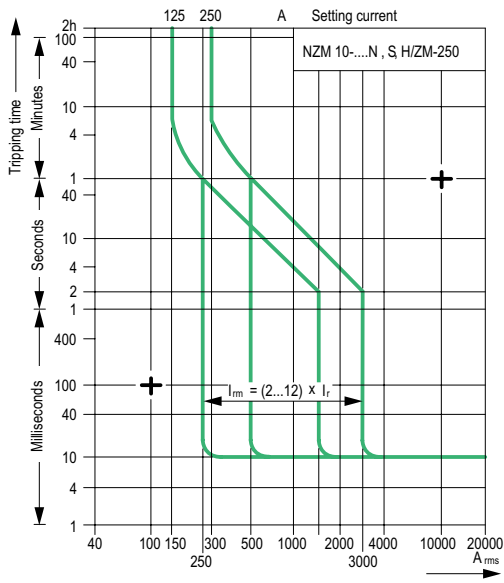

With selectivity settings

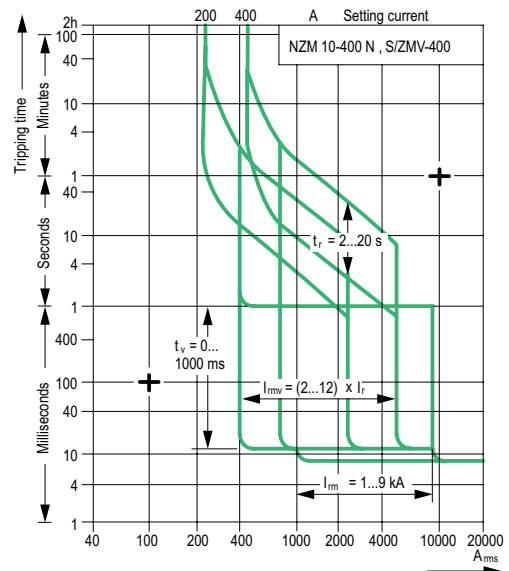
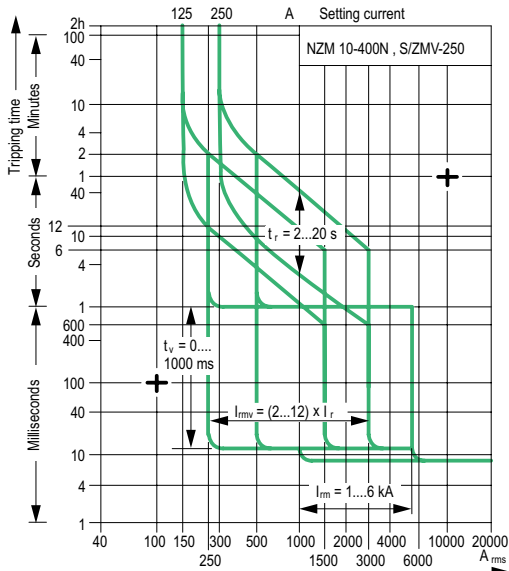

Circuit-Breakers, NZM 10 Tripping Characteristics

Inverse time and Instantaneous response

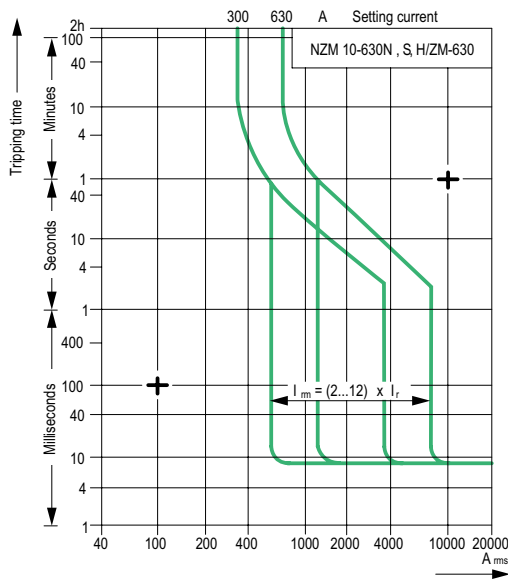

With selectivity settings

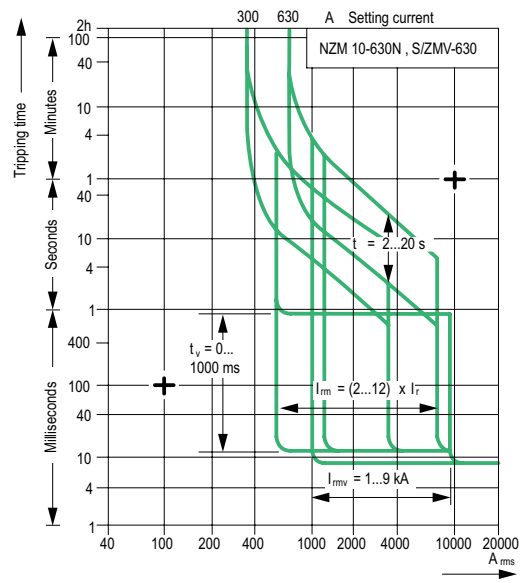

The tripping characteristics show the tripping time of the breakers in relation to the response current. The mean values of the tolerance bands are indicated at an ambient temperature of 20°C, starting from cold.

Let-through current \hat{I}_D

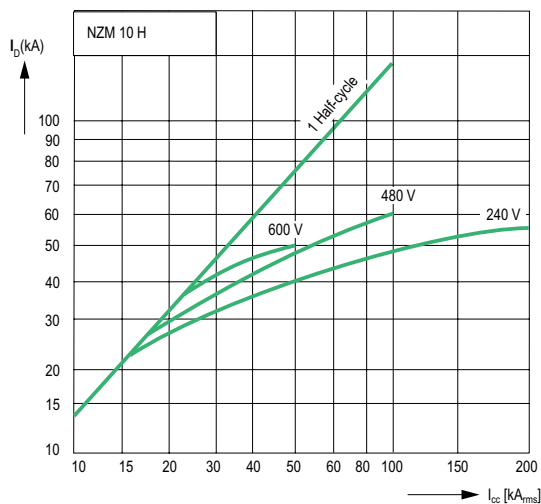

Let-through energy I^2t

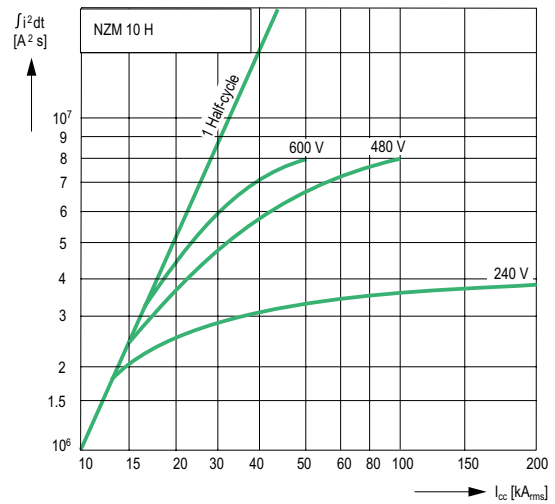

Molded Case Circuit Breakers, Disconnect Switches Technical Data for NZM H4, NZM(H)6(B), NZM(H)9, NZM 12

1	2	3	4	5	6	7	8	
Molded Case Circuit Breakers	3-pole	NZMH 4¹⁾ ...CNA	NZM 6B... /ZM6A...NA	NZM H6... /ZM6A...NA	NZM 9... /ZM9A...NA	NZMH 9... /ZM9A...NA	NZM 12...²⁾ /ZM(A)...NA	
Frame Size	A	80	125	125	250	250	1000	
IEC 60 947-2 Circuit Breaker Electrical Ratings								
Rated impulse withstand voltage U_{imp}	V	8000	8000	8000	8000	8000	—	
Rated operational voltage U_o 50/60 Hz	V	500	690	690	690	690	—	
Rated short-circuit making capacity I_{cm}	kA	220	275	275	73	220	—	
Short Circuit Interrupting Ratings:								
I_{cu} IEC/EN 60 947 Test cycle O-t-CO								
I_{cs} IEC/EN 60 947 Test cycle O-t-CO-t-CO								
220 – 240 V 50/60 Hz	I_{cu}	kA	100	125	125	35	100	—
	cos ϕ		0.2	0.2	0.2	0.25	0.2	—
	I_{cu}	kA	75	95	95	18	75	—
380-400/415 V 50/60 Hz	cos ϕ		0.2	0.2	0.2	0.3	0.2	—
	I_{cu}	kA	100/65	100/90	100/90	35	100/90	—
	cos ϕ		0.2	0.2	0.2	0.25	0.2	—
500 V 50/60 Hz	I_{cs}	kA	50/33	50/45	50/45	18	75/68	—
	cos ϕ		0.25	0.25	0.25	0.3	0.2	—
	I_{cu}	kA	20	35	35	25	65	—
660/690 V 50/60 Hz	cos ϕ		0.3	0.25	0.25	0.25	0.2	—
	I_{cs}	kA	10	18	18	13	33	—
	cos ϕ		0.5	0.3	0.3	0.3	0.25	—
DC voltage $T \leq 15$ ms	I_{cu}	kA	—	20	20	10	28	—
	cos ϕ		—	0.3	0.3	0.5	0.25	—
	I_{cs}	kA	—	5	5	10	14	—
110 V DC			—	0.7	0.7	0.5	0.3	—
250 V DC								
440 V DC								
DC voltage $T \leq 15$ ms								
110 V DC								
250 V DC								
440 V DC								
UL 489/CSA 5 Short Circuit Interrupting Ratings								
240 V 60 Hz	kA	—	25	100	30	200	65	
480 V 60 Hz	kA	—	25	65	25	85	65	
600 V 60 Hz	kA	—	14	25	18	42	50	

Circuit Breakers
Disconnect Switches, Molded Case Switches



General technical data

Standards	UL 489, CSA 22.2 # 5.1 IEC/EN 60 947-2, VDE 0660
Climatic proofing	Damp heat, constant, to IEC 60 068-2-3 Damp heat, cyclic, to IEC 60 068-2-30
Ambient temperature, min./max. °C	
Open	–25/+55 (Lower temperatures on request)
Enclosed	–25/+40 (Lower temperatures on request)
Mechanical shock resistance	25 g (shock duration 20 ms)

Mounting position

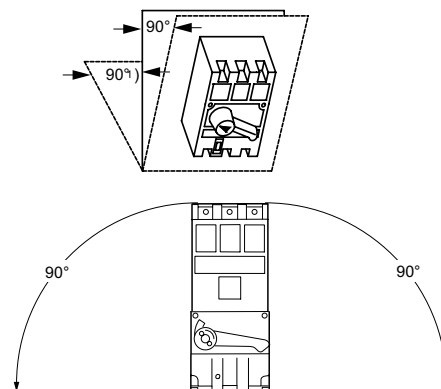

1) Type **NZMH 4**...-CNA Thermal-Magnetic devices (16 – 80 Amps) are rated as circuit breakers per IEC/EN 60 947-2 only. Consult page 8/ 5 for further info.
2) Type **NZM 12**...- NA circuit breakers are UL/CSA only. Consult Moeller Electric for IEC/EN rated versions.

Molded Case Circuit Breakers, Disconnect Switches

Technical Data for NZM H4, NZM(H)6(B), NZM(H)9, NZM 12

1	2	3	4	5	6	7	8
Molded Case Circuit Breakers		NZMH4...-CNA¹⁾	NZM 6B.../ZM6A...NA	NZM H6.../ZM6A...NA	NZM 9.../ZM9A...NA	NZMH 9.../ZM9A...NA	NZM 12.../ZM(A)...NA²⁾
Frame Size	Amps	80	125	125	250	250	1000
Overload Trips							
Bimetal Type (directly heated)	Amps	4 – 80	15 – 125	15 – 125	63 – 250	63 – 250	—
Solid State Type	Amps	—	—	—	—	—	300 – 1000
Temperature compensation residual error in the range –25/+55 °C (reference 20 °C)	%/K	0.3	0.7	0.7	0.3	0.3	—
Undervoltage Trips							
Pull-in Voltage range	%U _s	85 – 110	85 – 110	85 – 110	85 – 110	85 – 110	85 – 110
Dropout voltage range	%U _s	70 – 35	70 – 35	70 – 35	70 – 35	70 – 35	70 – 35
Minimum command time	ms	10 – 15	10 – 15	10 – 15	10 – 15	10 – 15	10 – 15
Inrush Rating AC	VA	6.5	6.5	6.5	40	40	100
Sealing AC	VA	3.5	3.5	3.5	7	7	12
Inrush Rating DC	W	2.8	2.8	2.8	1.9	1.9	160
Sealing DC	W	2.8	2.8	2.8	1.9	1.9	3.6
Shunt Trips							
Pull-in Voltage range	% U _s	70 – 110	70 – 110	70 – 110	70 – 110	70 – 110	70 – 110
Minimum command time	ms	10 – 15	10 – 15	10 – 15	10 – 15	10 – 15	10 – 15
Inrush Rating AC	VA	50	50	50	150	150	350
Sealing AC	VA	—	—	—	15	15	20
Inrush Rating DC (intermittent duty operation)	W	40	40	40	120	120	200
Switching times							
Tripping in the event of a short-circuit							
Minimum command time	ms	2	3	3	4	4	6
Opening delay	ms	0.3	0.3	0.3	6	0.3	12
Total opening delay	ms	5	6	6	20	6	25
Opening delay with:							
Shunt Trips (100% of rated coil voltage)	ms	10 – 20	10 – 20	10 – 20	10 – 20	10 – 20	15 – 25
Undervoltage Trips	ms	15 – 20	15 – 20	15 – 20	15 – 20	15 – 20	20 – 25
NHI, VHI, AHI, RHI auxiliary contacts³⁾							
IEC/EN 60 947 Ratings							
Rated operational current I _e							
AC-15	115 V 50 Hz	A	6	6 (1)	6 (1)	6 (1)	6 (1)
	230 V 50 Hz	A	6	6 (1)	6 (1)	6 (1)	6 (1)
	400 V 50 Hz	A	4	4 (1)	4 (1)	4 (1)	4 (1)
DC-13 (L/R ≤ 200 ms)	24 V DC	A	1	1 (1)	1 (1)	1 (1)	1 (1)
	60 V DC	A	0.8	0.8 (0.4)	0.8 (0.4)	0.8 (0.4)	0.8 (0.4)
	110 V DC	A	0.7	0.7 (0.2)	0.7 (0.2)	0.7 (0.2)	0.7 (0.2)
	220 V DC	A	0.3	0.3 (0.1)	0.3 (0.1)	0.3 (0.1)	0.3 (0.1)
Lifespan, electrical							
to AC-15	Ops.		20000	20000	20000	20000	10000
to DC-13	Ops.		5000	5000	5000	7500	2500
Short-circuit rating without welding (contacts closed)							
Fuseless			PKZM 0–2.5	PKZM 0–2.5	PKZM 0–2.5	PKZM 0–2.5	PKZM 0–2.5
Fuses	A gL		10	10	10	10	10
UL/CSA Pilot Duty Ratings							
Type NHI	Pilot Duty		A 600/P 600	A 600/P 600	A 600/P 600	A 600/P 600	A 600
Type VHI, AHI, RHI			C 300	C 300	C 300	C 300	A 600

1) Type **NZMH 4...-CNA** Thermal-Magnetic devices (16 – 80 Amps) are rated as circuit breakers per IEC/EN 60 947-2 only. Consult page 8/5 for further info.

2) Type **NZM 12...-NA** circuit breakers are UL/CSA only. Consult Moeller Electric for IEC/EN rated versions.

3) For IEC/EN 60 947 ratings, values which appear in parenthesis apply to **VHI, AHI, and RHI** contacts. Otherwise, values apply to all contacts.

Disconnect Switches, Molded Case Switches
Circuit Breakers



Molded Case Circuit Breakers, Disconnect Switches Technical Data for NZM H4, NZM(H)6(B), NZM(H)9, NZM 12

1	2	3	4	5
UL/CSA Motor Disconnect Switches with adjustable thermal and magnetic trips IEC/EN Molded Case Circuit Breakers	3-pole	NZMH 4-...-CNA	NZM(H)6(B)/ZM6-..CNA	NZM(H)9/ZM 9-...CNA
Frame Size	Amps	80	125	250
Motor Disconnect Switches with adjustable thermal and magnetic trips				
General Technical Data		Page 8/77	Page 8/77	Page 8/77
IEC/EN 60 947-2 Circuit Breaker Ratings		Page 8/77, 78	Page 8/77, 78	Page 8/77, 78
UL 508/CSA 22.2 # 14 Motor Disconnect switches				
Adjustable range of thermal overload trips	Amps	4 – 80	15 – 125	63 – 250
HP Ratings	HP	Page 8/5	Page 8/14	Page 8/24
Auxiliary Contacts, Voltage Trips		Page 8/78	Page 8/78	Page 8/78

1	2	3	4	5
UL/CSA Motor Disconnect Switches without adjustable thermal and magnetic trips IEC/EN Switch-Disconnectors	3-pole	N 6-...CNA	N 9-...CNA	N 12-...CNA
Frame Size	Amps	150	250	1200
Motor Disconnect Switches without adjustable thermal and magnetic trips				
General Technical Data		Page 8/77	Page 8/77	Page 8/77
IEC/EN 60 947-3 Switch Disconnecter Ratings:				
Rated Impulse Withstand Voltage	V	8000	8000	8000
Rated short-time withstand current I_{cw} (1 s current)	kA	3	7	20
Lifespan, mechanical	Ops.	20000	20000	30000
Maximum operating frequency	Ops./h	60	60	60
Lifespan, electrical	Ops. x 10 ³	10	10	10
	AC-1	5	5	5
	AC-2, AC-3	1	0.5	0.5
	DC-2, DC-5			
UL 508/CSA 22.2 # 14 Motor Disconnect switches				
HP Ratings		Page 8/15	Page 8/25	Page 8/33
Auxiliary Contacts, Voltage Trips		Page 8/78	Page 8/78	Page 8/78

Mounting Position

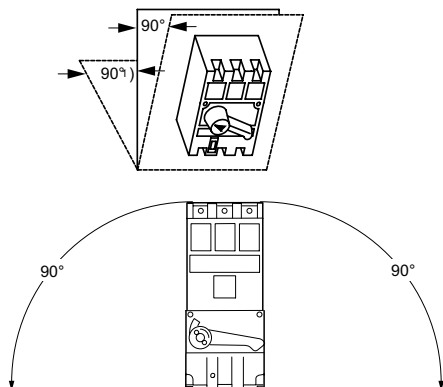

Molded Case Circuit Breakers, Disconnect Switches

Technical Data for NZM H4, NZM(H)6(B), NZM(H)9, NZM 12

Type		NZMH 4-...-OBI-CNA	NZMH 4-...-CNA	NZM(H)6(B).../ZM 6(A)...-(C)NA NZM(H)6(B).../ZM 6...-OBI-CNA	NZM(H)6(B)-160/ZM 6(A)-125-(C)NA NZM(H)6(B)-160/ZM 6-125-OBI-CNA
Maximum continuous current	A	18	80	100	125
Field Wiring Terminals Conductor Cross-Section		1 Conductor: AWG 14 – 3 Cu Only	1 Conductor: AWG 14 – 3 Cu Only	1 Conductor: AWG 14 – 1/0 Cu Only Up to 90A, 60/75°C Cable 100A, 60°C Cable	1 Conductor: AWG 4 – 3/0 Cu Only 125A, 60°C Cable
Terminal Torque Rating	Nm	4	4	10	15

Type		NZM(H) 9.../ZM 9(A)...-(C)NA NZM(H) 9.../ZM 9...-OBI-CNA	NZM12-.../ZM 12(V)(A)-...-NA	
Maximum continuous current	A	250	800	1000
Field Wiring Terminals Conductor Cross-Section		1 Conductor: AWG 8 – Kcmil 300 Cu only	1 Conductor: Kcmil 250 – 600 2 Conductors: AWG 3/0 – Kcmil 500 3 Conductors: Kcmil 250 – 400 Cu + Al	4 Conductors: AWG 2 – Kcmil 500 Cu + Al
Terminal Torque Rating	Nm	40	50	50

Type		N 6-...-CNA		N 9-...-CNA	N 12-...-CNA	
Maximum continuous current	A	100	150	250	800	1000 1200
Field Wiring Terminals Conductor Cross-Section		1 Conductor: AWG 14 – 1/0 Cu Only 75°C Cable	1 Conductor: AWG 4 – 3/0 Cu Only 75°C Cable	1 Conductor: AWG 8 – Kcmil 300 Cu Only	1 Conductor: Kcmil 250 – 600 2 Conductors: AWG 3/0 – Kcmil 500 3 Conductors: Kcmil 250 – 400 Cu + Al	4 Conductors: AWG 2 – Kcmil 500 Cu + Al 4 Conductors: AWG 2 – Kcmil 500 Cu + Al
Terminal Torque Rating	Nm	10	15	40	50	50 50

Note:
All devices shown above except Types **NZM 12-...** are dual rated UL/CSA and IEC/EN.
Consult Moeller Electric for IEC/EN Conductor Cross-section information.



Molded Case Circuit Breakers, Technical Data for NZM 7..., NZM 10...

1	2	3	4	5	6	
Molded Case Circuit Breakers		NZM 7(A)...N-NA¹⁾	NZM 10-...N-NA	NZM 10-...S-NA	NZM 10-...H-NA	
Frame Size	Amps	150	600	600	600	
IEC 60 947-2 Circuit Breaker Electrical Ratings						
Rated impulse withstand voltage U_{imp}	V	8000	8000	8000	8000	
Rated operational voltage U_e 50/60 Hz	V	690	690	690	690	
Oversvoltage category/pollution degree		III/3	III/3	III/3	III/3	
Short Circuit Interrupting Ratings:						
Rated short-circuit making capacity I_{cm}	kA	94.5	143	220	440	
Rated short-circuit breaking capacity I_{cs}						
I_{cu} IEC/EN 60 947 Test cycle O-t-CO						
I_{cs} IEC/EN 60 947 Test cycle O-t-CO-t-CO						
230 V AC	I_{cu}	kA	45	65	100	200
	I_{cs}	kA	45	33	50	100
400/415 V AC	I_{cu}	kA	35	45	65	100
	I_{cs}	kA	35	23	33	50
440 V AC	I_{cu}	kA	25	45	55	85
	I_{cs}	kA	19	23	28	43
500 V AC	I_{cu}	kA	12	30	42	65
	I_{cs}	kA	9	15	21	33
690 V AC	I_{cu}	kA	6	20	25	30
	I_{cs}	kA	6	10	13	15
UL 489/CSA 5 Short Circuit Interrupting Ratings						
	240 V 60 Hz	kA	65	65	100	200
	480 V 60 Hz	kA	25	42	65	100
	600 V 60 Hz	kA	—	35	42	50

General technical data

Standards	UL 489, CSA 22.2 # 5.1 IEC/EN 60 947-2, VDE 0660
Shock Hazard Protection	Finger-Safe, Back of Hand safe
Climatic proofing	Damp heat, constant, to IEC 60 068-2-3 Damp heat, cyclic, to IEC 60 068-2-30
Ambient temperature Min/Max °C	-25/+40 (At 100% loading)
Mechanical shock resistance	20 g (shock duration 20 ms)

Mounting

From a vertical position, up to 90°
in any direction

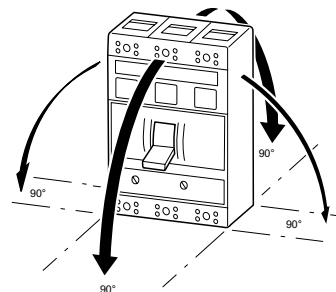

1) Type **NZM 7(A)-...N-NA** molded case circuit breaker UL/CSA only. Conformity with data shown per IEC/EN 60 947-2 pending. Consult Moeller Electric for IEC/EN version.

Molded Case Circuit Breakers

Technical Data for NZM 7..., NZM 10...

1	2	3	4	5	6
Molded Case Circuit Breakers			AC = 50/60 Hz	NZM 7...	NZM 10...
Auxiliary contact types			EK...(NHI/RHI)	VHI	NHI/RHI/VHI
IEC/EN 60 947 Electrical Ratings					
Rated operational current I _e					
AC-15	115 V	A	6	4	6
	230 V	A	6	4	6
	400 V	A	4	2	3
	500 V	A	2	1	1.5
DC-13	24 V	A	6	3	1
	60 V	A	3	1.5	0.8
	110 V	A	1	0.5	0.7
	220 V	A	0.5	0.2	0.3
Short-circuit protection: Max. Fuse, IEC Type		A	10	10	6
Max. Miniature Circuit Breaker		A	10	6	6
Terminal capacity: IEC/EN: 1 or 2 conductors, solid or stranded		mm ²	0.75 – 2.5	0.75 – 2.5	0.5 – 2.5
UL/CSA		AWG	18 – 14	18 – 14	18 – 14
UL/ CSA Electrical Ratings					
Pilot Duty Ratings AC/DC			A 600/ P 300	C 300/ Q 300	—
Current Ratings			—	—	10A @ 600 VAC .5A @ 125 VDC .25A @ 250 VDC ¹⁾
Voltage Trips					
Shunt Trip					
Operational voltage rating U _e		V AC	12 – 480		24 – 600
		V DC	12 – 125		24 – 600
Operating range (U _s = Rated Control Voltage)		AC	0.7 – 1.1 x U _s		0.7 – 1.1 x U _s
		DC	0.7 – 1.1 x U _s		0.85 – 1.1 x U _s
Rating					
Pull-in		AC/DC	2/2		5/3
Sealing		AC/DC	—		3/3
Undervoltage Trips					
Operational voltage rating U _e		V AC	24– 480		24 – 600
		V DC	24 – 125		24 – 600
Operating range: Dropout		AC/DC	0.7 – 0.35 x U _s		0.7 – 0.35 x U _s
Pickup		DC/DC	0.85 – 1.1 x U _s		0.85 – 1.1 x U _s
Rating: Pull-in		AC/DC	2/2		5/3
Sealing		AC/DC	2/2		5/3
Terminal capacity					
IEC/EN: 1 or 2 conductors, solid or stranded		mm ²	0.75 – 2.5		0.5 – 2.5
UL/CSA		AWG	18 – 14		18 – 14
Remote Control Drives					
Rated Control Voltage U _s		V AC	48 – 240		110 – 415
		V DC	24 – 240		24 – 240
Operating range		AC	0.85 – 1.1 x U _s		0.8 – 1.1 x U _s
		DC	0.85 – 1.1 x U _s		0.85 – 1.1 x U _s
Power Draw					
		110/120 V AC	VA	400	240
		220/240 V AC	VA	400	320
		380/415 V AC	VA	1000	440
		24 V DC	W	350	240
		48/60 V DC	W	400	240
		100/130 V DC	W	—	240
		110/120 V DC	W	400	—
		220/240 V DC	W	400	240
Total closing/opening time		ms	100		60/30
Lifespan, mechanical		Operations	20000		10000
Maximum operating frequency		Ops./h	20		20
Terminal capacity: IEC/EN: 1 or 2 conductors, solid or stranded		mm ²	0.75 – 2.5		0.5 – 2.5
UL/CSA		AWG	18 – 14		18 – 14

1) Above 150 VDC, same polarity



Molded Case Switches, NZM 7... and 10... Technical Data, Terminal Capacity

1	2	3	4
UL/CSA Molded Case Switches IEC/EN Switch-Disconnectors		NZM 7-...-NA	NZM 10...N/B-NA
Frame Size	A	200	600
General Technical Data UL 1087/ CSA 22.2 # 5.2 Molded Case Switches IEC/EN 60 947-3 Switch Disconnector Ratings:		Refer to p. 8/45	Refer to p. 8/61
Rated Impulse Withstand Voltage	V	8000	8000
Rated short-time withstand current I_{cw} (1 s current)	kA	3.5	8
Overvoltage category/pollution degree		III/3	III/3
Lifespan, mechanical	Ops.	20000	20000
Maximum operating frequency	Ops./h	120	60
Lifespan, electrical			
AC-1	400 V/690 V	3000/2000	10000

Terminal Capacity

1	2	3	4
Type	NZM 7(A)-...N-NA Molded Case Circuit Breaker	NZM 7-...-NA Molded Case Switch	NZM 10...-NA Molded Case Circuit Breakers and Switches
Maximum continuous current	A 150	200	
Field Wiring Terminals Conductor Cross-Section	1 Conductor: AWG 14...250 kcmil Cu Only	1 Conductor: AWG 14...250 kcmil Cu Only	Refer to Page 8/71
Terminal Torque Rating	Nm 14	14	
Bolt-on Connection size	M8	M8	

Let-Through Values for UL/CSA Fuseless Current Limiting Circuit Breakers

1	2	3	4
Type	NZMH 6-.../ZM 6A-...-NA	NZMH 9-.../ZM 9A-...-NA	NZM 10H-.../ZM 10(A)-...-NA
Maximum continuous current	A 125	250	600
Current Limiting Values @	240V 480V 600V	240V 480V 600V	240V 480V 600V
Threshold Current			
RMS Sym	kA 7.5 7.5 7.5	16.25 16.25 16.25	39 39 39
Peak	kA 9 10 10.6	18 21 23	34 42 40
$I^2t \times 10^3$	A ² s 350 430 468	1500 2000 2204	2800 5500 5500
Intermediate Current			
RMS Sym	kA 50 42 14	100 50 30	125 65 42
Peak	kA 22 26 16	36 38 32	50 52 45
$I^2t \times 10^3$	A ² s 800 1300 1000	1800 5000 5000	3500 6600 7200
High Interrupting Capacity			
RMS Sym	kA 100 65 25	200 85 42	200 100 50
Peak	kA 30 35 21	42 48 39	55 61 48
$I^2t \times 10^3$	A ² s 1000 2100 1590	3200 6000 6300	4000 8000 8000

Circuit Breakers
Disconnect Switches, Molded Case Switches



Molded Case Circuit-Breakers and Disconnect Switches

Dimensions for Type NZMH 4, 6 and 9

Circuit-breakers

NZMH 4-...-OBI-CNA
NZMH 4-...-CNA

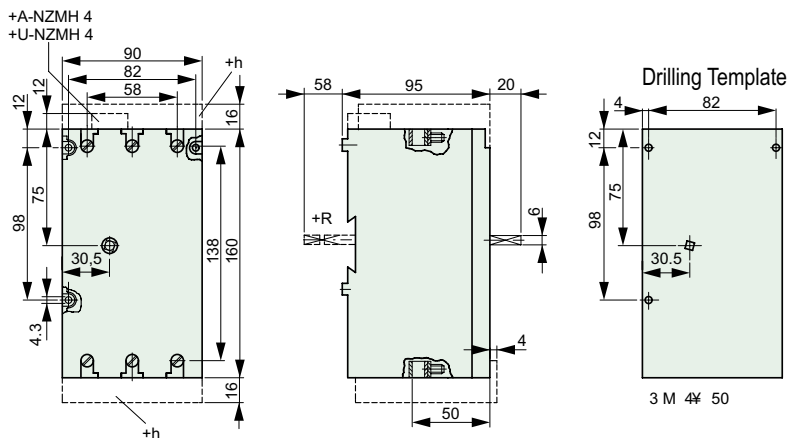

N6-...-CNA
NZMH 6/ZM 6(A)-(C)NA
NZM 6B/ZM 6(A)-(C)NA
NZM(H)6B/ZM 6-OBI-CNA

Type	a	a ₁	b	d	e	f	g	h	k
N 6-...-CNA	—	133	109	—	125	92	95	106	7
NZMH 6/ZM 6(A)-(C)NA	210	—	109	180	—	112	95	126	7
NZM 6 B/ZM 6(A)-(C)NA	210	—	109	180	—	112	95	126	7

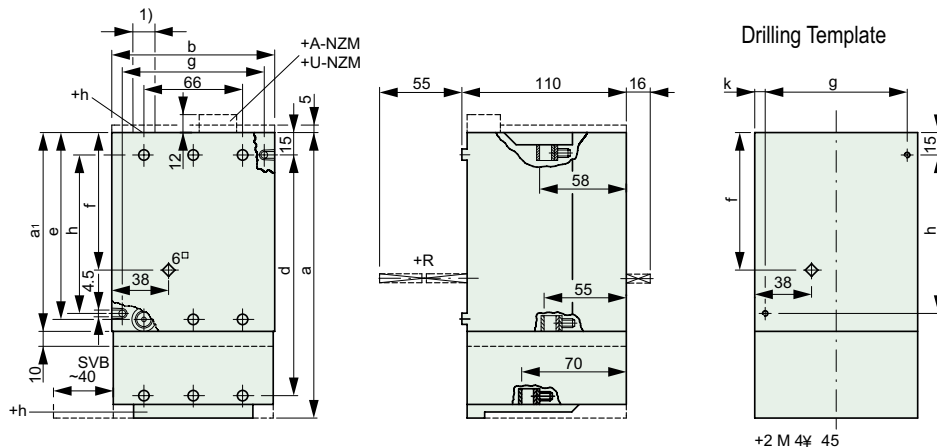

N 9-...-CNA
NZM 9/ZM 9(A)-...(C)NA
NZMH 9/ZM 9(A)-...(C)NA
NZMH 9/ZM 9-OBI-CNA

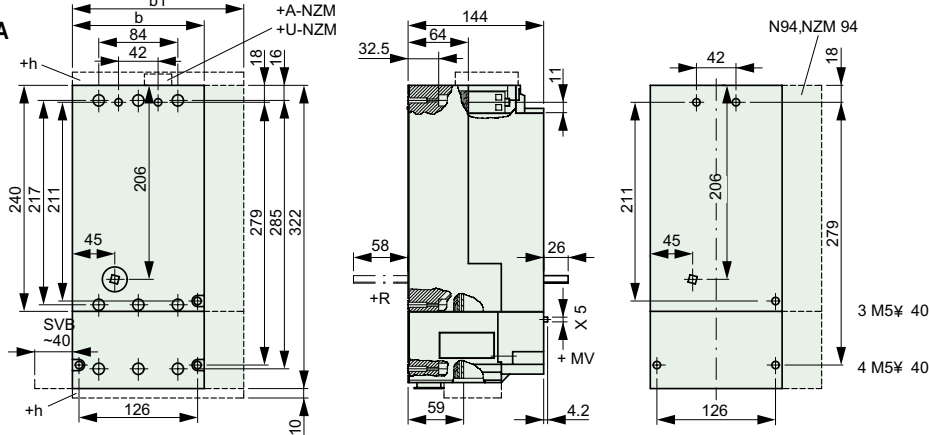

Type	b	b ₁
N 9-...-CNA	140	—
NZM 9/ZM9...-NA	140	—
NZMH 9/ZM9...-NA	140	—

Notes: Safety vertical clearance between upper edge of NZM circuit-breakers and conductive materials with a different potential:

Type	Value
NZM 4	40 mm
NZM 6	60 mm
NZM 9	100 mm

+R: When switch shaft extended to the rear: provide 20 mm diameter hole in mounting plate for switch shaft. Front switch shaft is then omitted except for frame sizes 4 and 6.

Disconnect Switches, Molded Case Switches



Molded Case Circuit-Breakers and Disconnect Switches Dimensions for Type NZM 12

N12...-CNA (630, 800)
NZM 12-.../ZM 12 (A)(V)-...-NA (630, 800)

N 12-1000-CNA
NZM 12-1250/ZM (V)-1000-NA

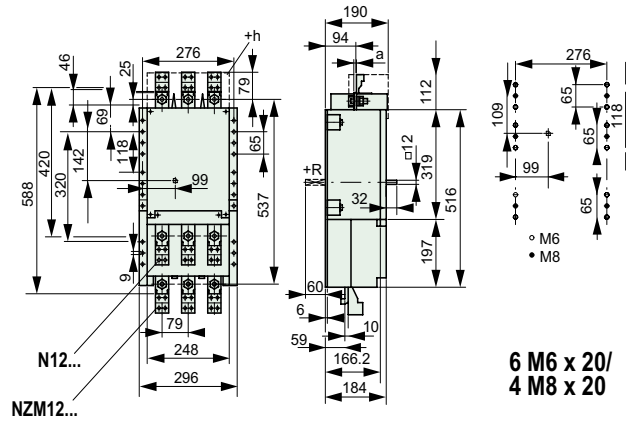
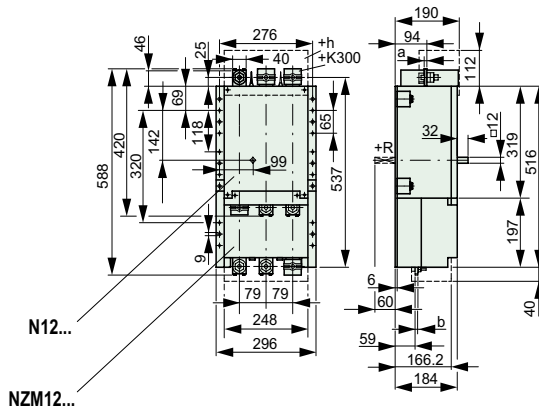

Terminal bolts
M16 x 50

Type	630	800	1250
NZM 12	a	8	10
	b	8.5	8.5
ZM 12	b	10	15

N 12-1200-CNA

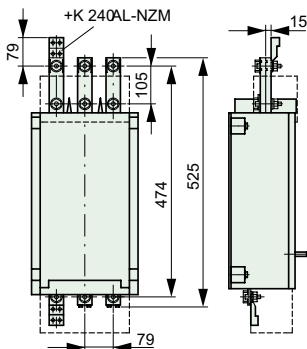

Notes: Safety vertical clearance between upper edge of NZM circuit-breakers and conductive materials with a different potential:

Type	Clearance
NZM 12	180 mm

Molded Case Circuit-Breakers and Disconnect Switches Dimensions for Type NZMH 4, 6, 9 and 12

Standard handle

Door coupling rotary handle

Handle for switch shaft extended to rear

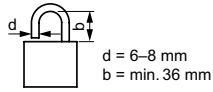

For NZM 4

H 4 U

H 6(-NA)

H 6 R(-NA)

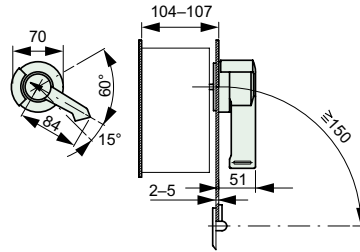
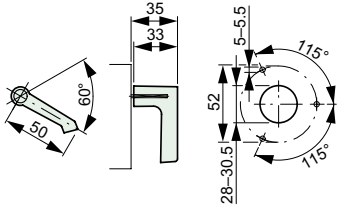

Mounting opening as on left, but turned clockwise through 90°

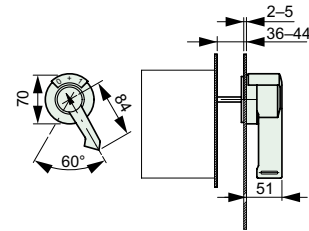

For NZM 6

H 6 U

H 6(-NA)

H 6 R(-NA)

Mounting opening as on left, but turned clockwise through 90°

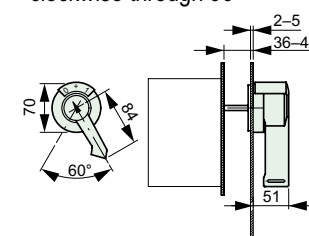
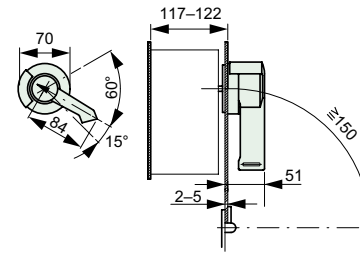
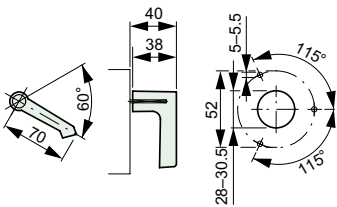

For NZM 9

H 9 U

H 9(-NA)

H 9 R(-NA)

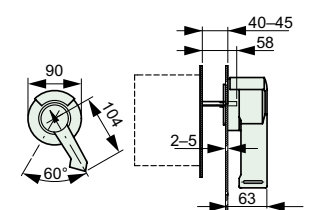
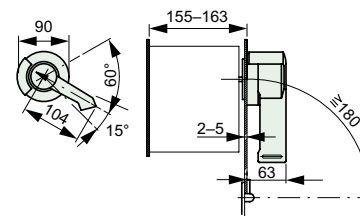
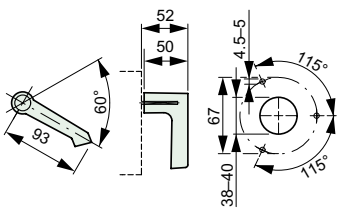

For NZM 12

H 12 U

H 12(-NA)

H 12 R(-NA)

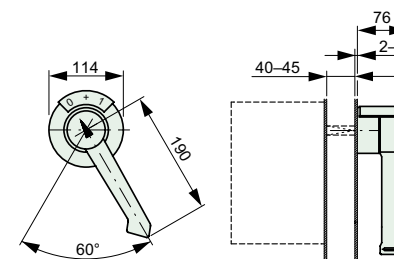
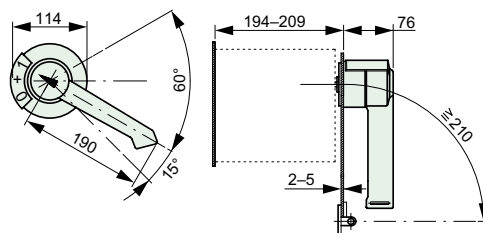
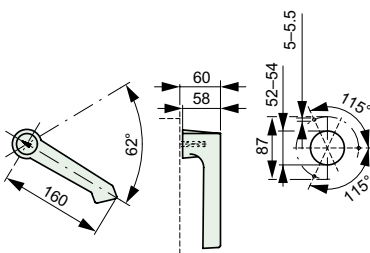

K(V), KU coupling kits

KV-2 NZM

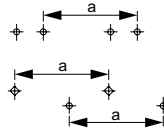
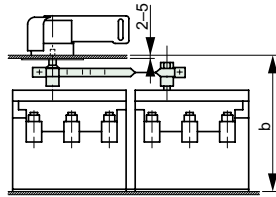
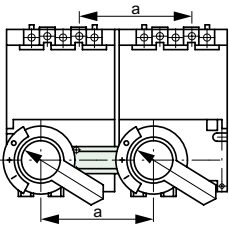

Type	a	b
NZM 4	125	145–185
NZM 6	125	150–190
NZM 9	150	190–240
NZM 12	300	240–300

Molded Case Circuit Breakers and Switches

Dimensions for Type NZM 7...

Circuit Breakers, Molded Case Switches

NZM 7.....-NA

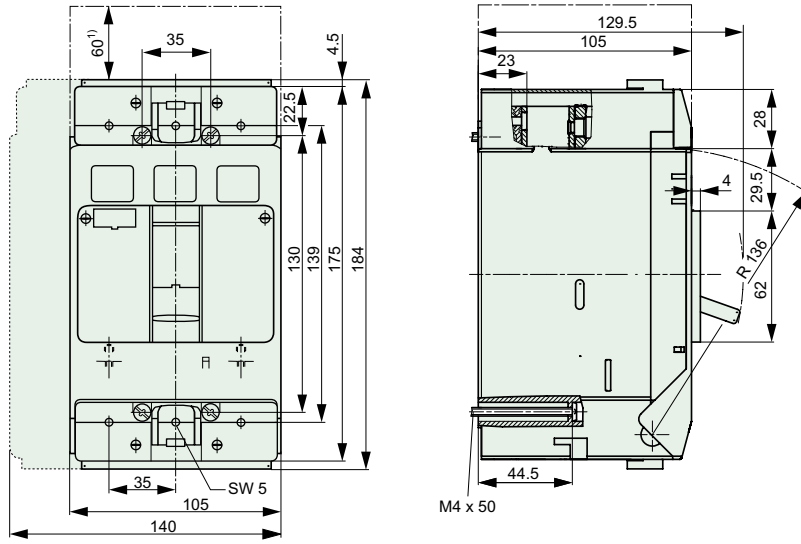

Shunt Trips, undervoltage Trips and Early-Make auxiliary contacts

A-, U-, VHI-NZM 7

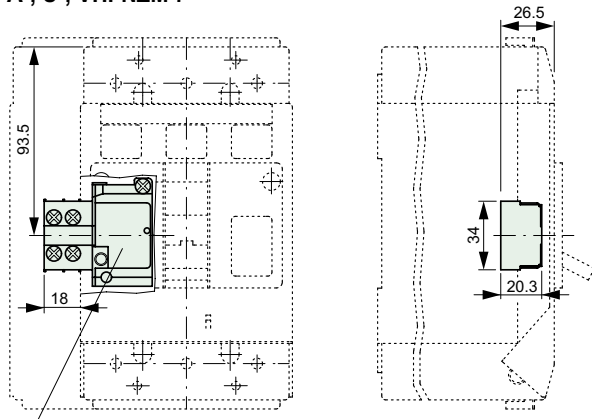

Insulating frame

RT-NZM 7

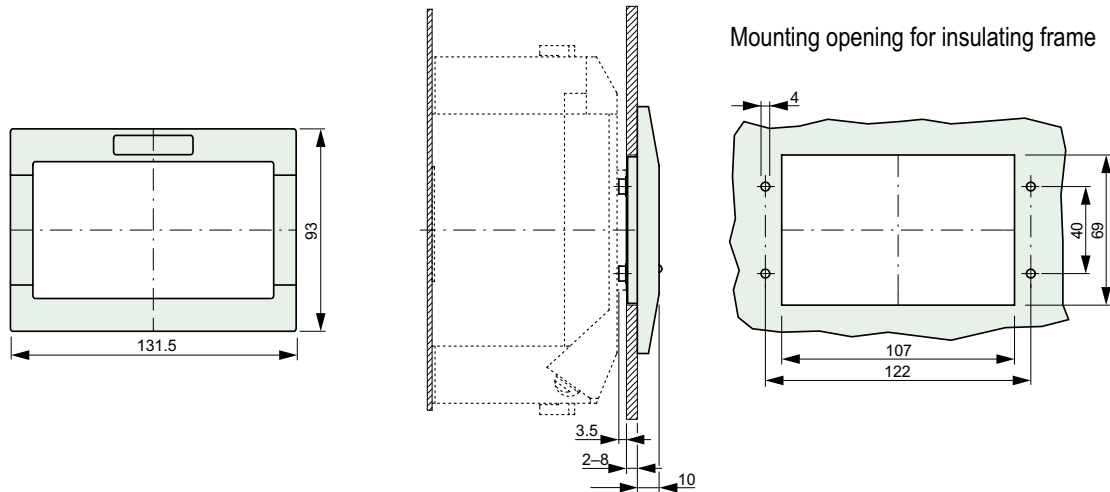

Disconnect Switches, Molded Case Switches

Circuit Breakers

Rotary drive/rotary handle for open mounted breakers and switches

DA(OV)-NZM 7 HU-NZM 7

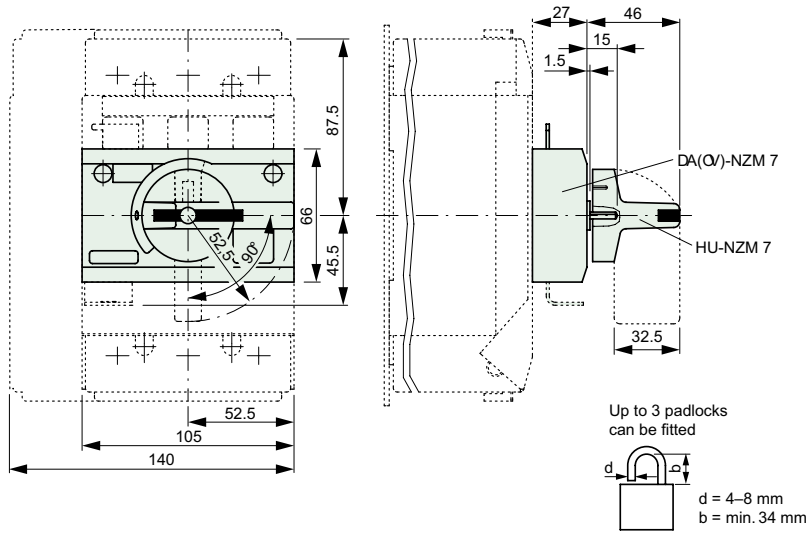

Extension shaft

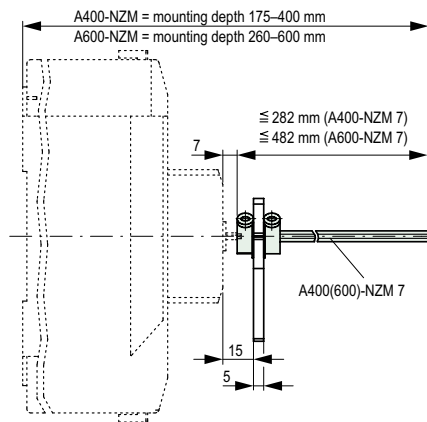

Door interlocking handle for base mounted breakers and switches

(R)H-NZM 7
HOV-NZM 7

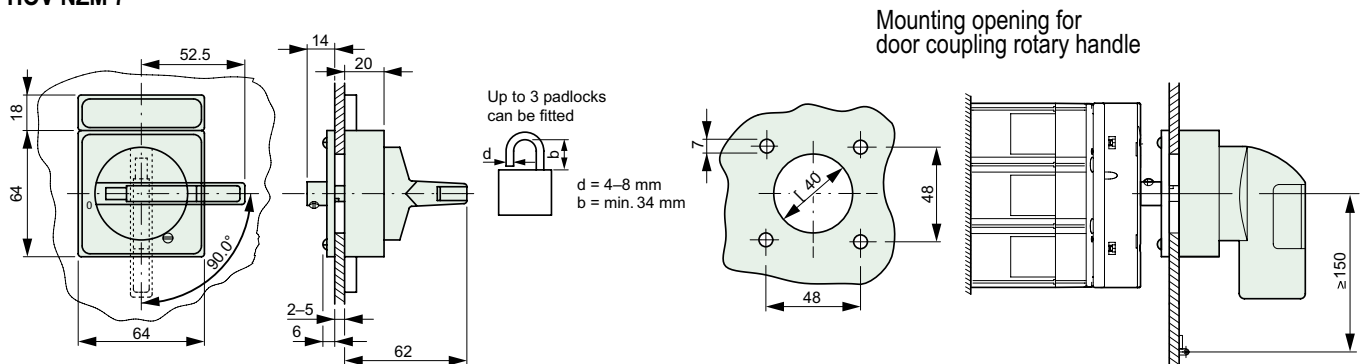

Molded Case Circuit Breakers and Switches Dimensions for Type NZM 7

Mechanical interlock

KV-2 NZM 7

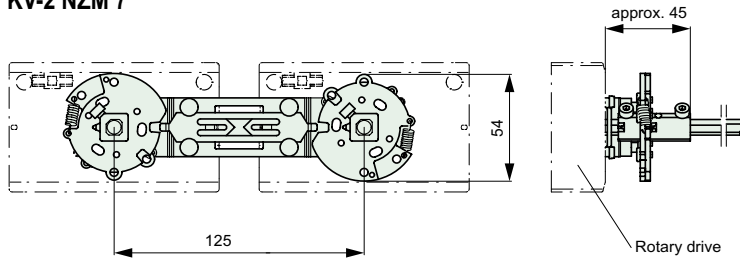

Clip plate

C-NZM 7

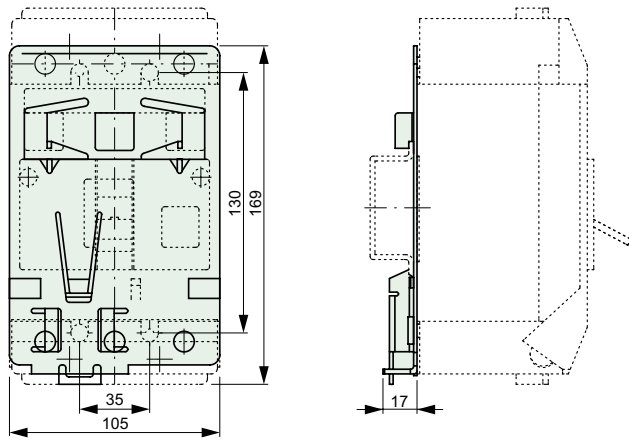

Cable lug/cable lug cover KA 250-NZM 7

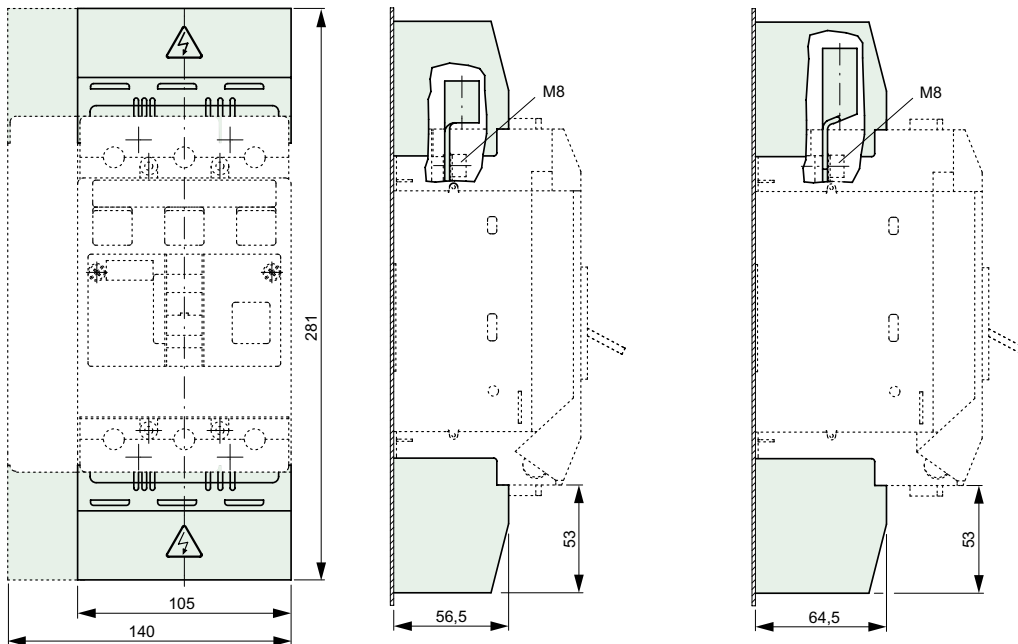

Side wall operator

SWA-NZM 7

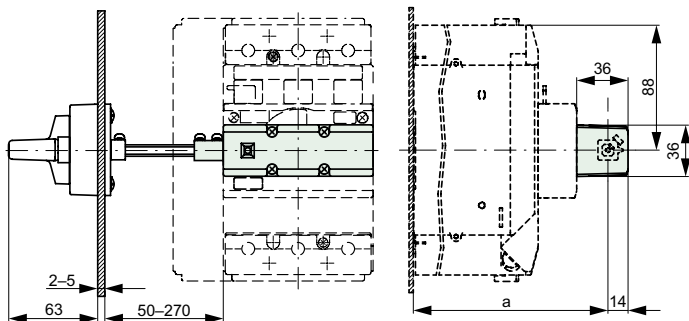

Type	NZM 7...-NA
a	154
b	134

Mounting bracket for side wall operator

MSWA-NZM 7

Mounting aperture for rotary handle

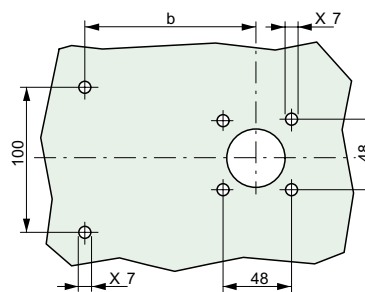
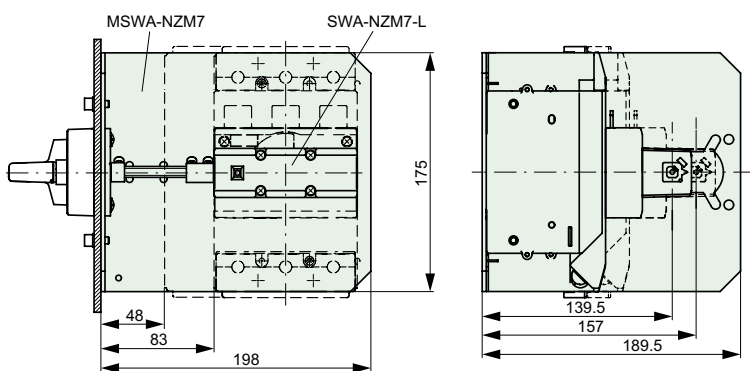

Remote Control Drive

R-NZM 7

Type	NZM 7(A)...N-NA NZM 7...-NA
a	232.2
b	251

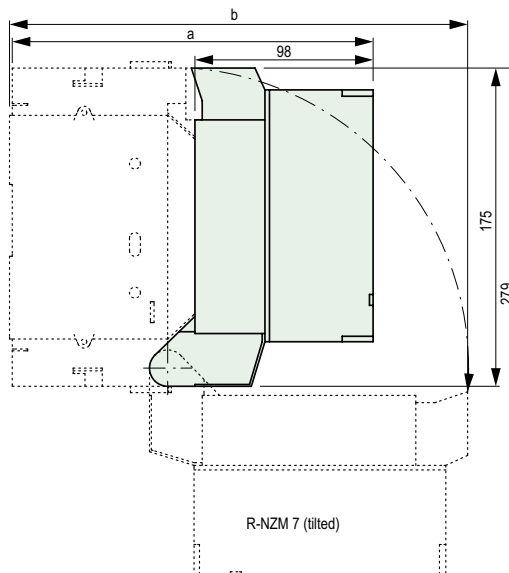
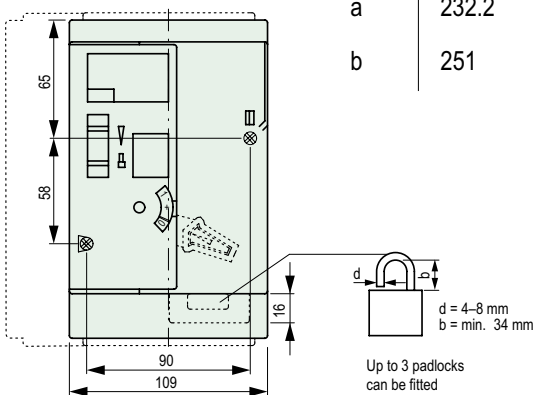

Molded Case Circuit Breakers and Switches

Dimensions for Type NZM 10...

Circuit Breakers, Molded Case Switches

NZM 10...-NA

When mounting devices side by side, 15mm clearance is required between them.

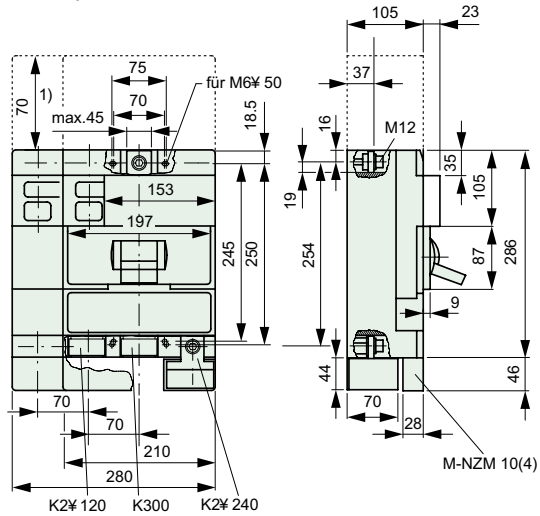

1) Safety clearance is required to conductive materials having a different potential; does not apply to connected stripped conductors.

Rotary drive

D-NZM 10

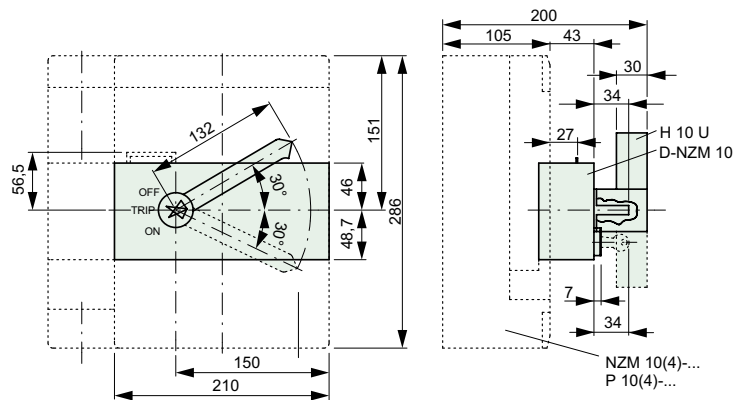

Door Interlocking handle

(R)H 10-NA

Drilling template (R)H 10-NA

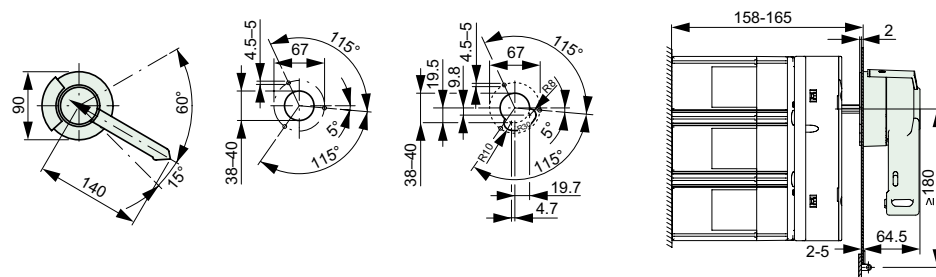

Pushbuttons for enclosed breakers/switches operated with a remote control drive

MD-NZM 10
MDV-NZM 10

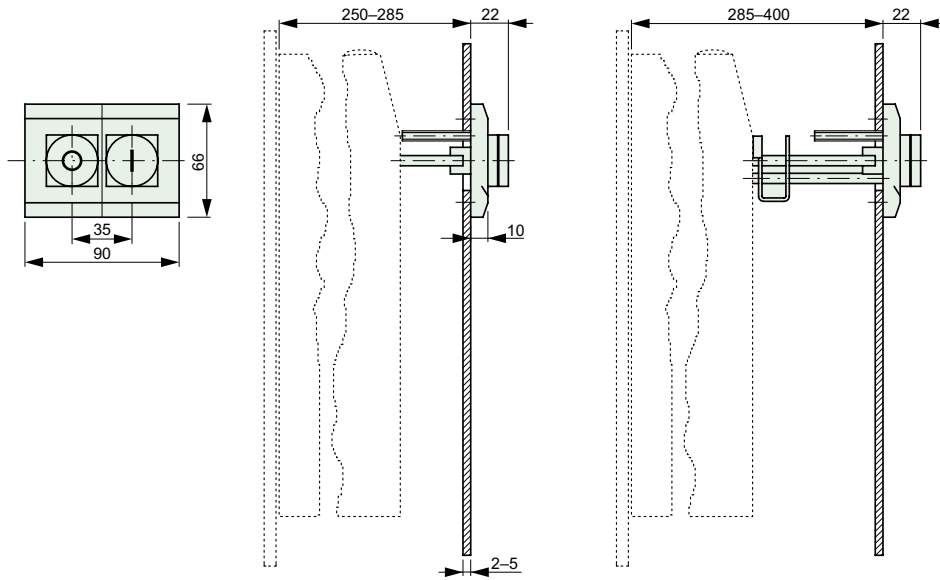

Mounting opening for pushbuttons

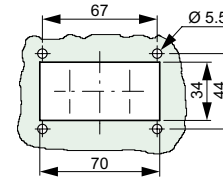

Protective cover for door cutout

RTR-NZM 10

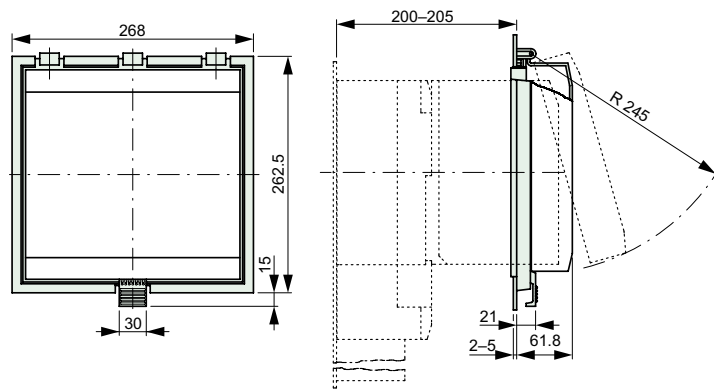

Mounting opening

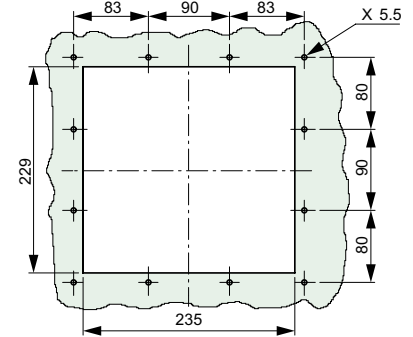

Ground Fault Trip Unit

TV-NZM 10

