

# Inductive Cylinder Position Sensors



Housing Style	Part Number	ID Number	Features	Sensing Range (mm)	Output
<b>CRS - microfast® Connector</b> 	Bi 2-CRS232-ADZ30X2-B3131/S34	T4275093	WFI	2	2-Wire AC/DC
	Bi 2-CRS260-ADZ30X2-B3131/S34	T4275493	WFI	2	
	Bi 2-CRS287-ADZ30X2-B3131/S34	T4275893	WFI	2	
	Bi 2-CRS317-ADZ30X2-B3131/S34	T4276293	WFI	2	
	Bi 2-CRS343-ADZ30X2-B3131/S34	T4276493	WFI	2	
	Bi 2-CRS476-ADZ30X2-B3131/S34	T4276693	WFI	2	
	Bi 2-CRS524-ADZ30X2-B3131/S34	T4277093	WFI	2	
	Bi 2-CRS603-ADZ30X2-B3131/S34	T4277493	WFI	2	
	Bi 2-CRS705-ADZ30X2-B3131/S34	T4277893	WFI	2	
	Bi 2-CRS730-ADZ30X2-B3131/S34	T4278293	WFI	2	
	Bi 2-CRS959-ADZ30X2-B3131/S34	T4279093	WFI	2	
	Bi 2-CRS1159-ADZ30X2-B3131/S34	T4279493	WFI	2	
<b>CRS - minifast® Connector</b> 	Bi 2-CRS232-ADZ30X2-B1131/S34	T4270093	WFI	2	2-Wire AC/DC
	Bi 2-CRS260-ADZ30X2-B1131/S34	T4270493	WFI	2	
	Bi 2-CRS287-ADZ30X2-B1131/S34	T4270893	WFI	2	
	Bi 2-CRS317-ADZ30X2-B1131/S34	T4271293	WFI	2	
	Bi 2-CRS343-ADZ30X2-B1131/S34	T4271493	WFI	2	
	Bi 2-CRS476-ADZ30X2-B1131/S34	T4271693	WFI	2	
	Bi 2-CRS524-ADZ30X2-B1131/S34	T4272093	WFI	2	
	Bi 2-CRS603-ADZ30X2-B1131/S34	T4272493	WFI	2	
	Bi 2-CRS705-ADZ30X2-B1131/S34	T4272893	WFI	2	
	Bi 2-CRS730-ADZ30X2-B1131/S34	T4273293	WFI	2	
	Bi 2-CRS959-ADZ30X2-B1131/S34	T4274093	WFI	2	
	Bi 2-CRS1159-ADZ30X2-B1131/S34	T4274493	WFI	2	

Bi 2-CRS-XXXX-.. = Length of probe in mm.



Voltage	Switching Freq. (Hz)	Operating Current (mA) VAC/VDC	Operating Temp. (°C)	Protection	Housing	Probe	Power LED	Output LED	Mating Cord, Cable Length/Jacket	Wiring Diagram #	Wiring Diagrams
20-250 VAC/DC	30	≤400/300	-25 to +70	IP 67	Zinc	CPB	GN	Rd	KB 3T-*	1	<p><b>Diagram 1</b></p> <p><b>Diagram 2</b></p>
	30	≤400/300	-25 to +70	IP 67	Zinc	CPB	GN	Rd	KB 3T-*	1	
	30	≤400/300	-25 to +70	IP 67	Zinc	CPB	GN	Rd	KB 3T-*	1	
	30	≤400/300	-25 to +70	IP 67	Zinc	CPB	GN	Rd	KB 3T-*	1	
	30	≤400/300	-25 to +70	IP 67	Zinc	CPB	GN	Rd	KB 3T-*	1	
	30	≤400/300	-25 to +70	IP 67	Zinc	CPB	GN	Rd	KB 3T-*	1	
	30	≤400/300	-25 to +70	IP 67	Zinc	CPB	GN	Rd	KB 3T-*	1	
	30	≤400/300	-25 to +70	IP 67	Zinc	CPB	GN	Rd	KB 3T-*	1	
	30	≤400/300	-25 to +70	IP 67	Zinc	CPB	GN	Rd	KB 3T-*	1	
	30	≤400/300	-25 to +70	IP 67	Zinc	CPB	GN	Rd	KB 3T-*	1	
	30	≤400/300	-25 to +70	IP 67	Zinc	CPB	GN	Rd	KB 3T-*	1	
	30	≤400/300	-25 to +70	IP 67	Zinc	CPB	GN	Rd	KB 3T-*	1	
20-250 VAC/DC	30	≤400/300	-25 to +70	IP 67	Zinc	CPB	GN	Rd	RKM 311-*M	2	
	30	≤400/300	-25 to +70	IP 67	Zinc	CPB	GN	Rd	RKM 311-*M	2	
	30	≤400/300	-25 to +70	IP 67	Zinc	CPB	GN	Rd	RKM 311-*M	2	
	30	≤400/300	-25 to +70	IP 67	Zinc	CPB	GN	Rd	RKM 311-*M	2	
	30	≤400/300	-25 to +70	IP 67	Zinc	CPB	GN	Rd	RKM 311-*M	2	
	30	≤400/300	-25 to +70	IP 67	Zinc	CPB	GN	Rd	RKM 311-*M	2	
	30	≤400/300	-25 to +70	IP 67	Zinc	CPB	GN	Rd	RKM 311-*M	2	
	30	≤400/300	-25 to +70	IP 67	Zinc	CPB	GN	Rd	RKM 311-*M	2	
	30	≤400/300	-25 to +70	IP 67	Zinc	CPB	GN	Rd	RKM 311-*M	2	
	30	≤400/300	-25 to +70	IP 67	Zinc	CPB	GN	Rd	RKM 311-*M	2	
	30	≤400/300	-25 to +70	IP 67	Zinc	CPB	GN	Rd	RKM 311-*M	2	
	30	≤400/300	-25 to +70	IP 67	Zinc	CPB	GN	Rd	RKM 311-*M	2	

\* Length in meters.

### WIRING DIAGRAM

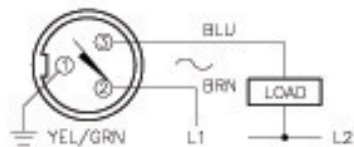

SHORT-CIRCUIT AND OVERLOAD PROTECTED

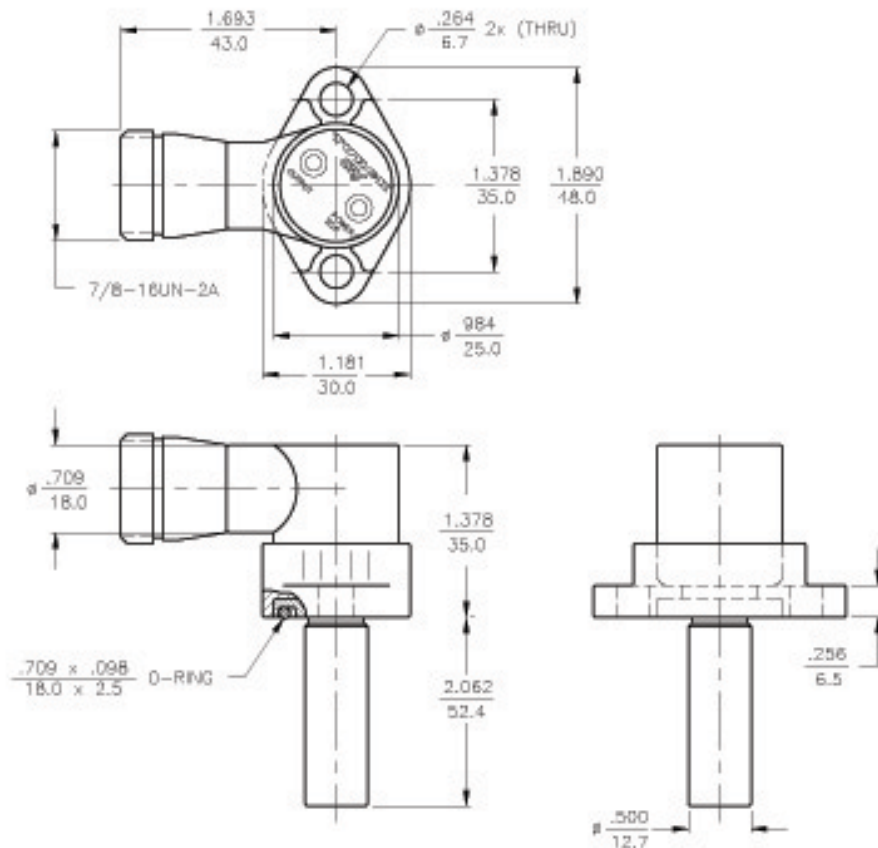

NOTES:

1. \*S34 DESIGNATES WELD FIELD IMMUNITY. SENSOR IS SUITABLE FOR USE ON RESISTANCE WELDING MACHINES.
2. ROTATION CAPABILITY OF THE CRS SWITCH IS 360°.

### SPECIFICATIONS

OPERATING VOLTAGE	20-250 VAC/DC
LINE FREQUENCY	40-60 Hz
HYSTERESIS (DIFFERENTIAL TRAVEL)	3-15% (5% TYPICAL)
VOLTAGE DROP ACROSS CONDUCTING SENSOR	≤ 6.0 V at 400 mA
OUTPUT FUNCTION	NORMALLY OPEN 3-WIRE AC/DC SELF-CONTAINED
SHORT-CIRCUIT PROTECTED	YES
TRIGGER CURRENT FOR OVERLOAD PROTECTION	≥ 500 mA
CONTINUOUS LOAD CURRENT	≤ 400 mA
LEAKAGE (OFF-STATE) CURRENT	≤ 1.7 mA
MINIMUM LOAD CURRENT	≥ 3.0 mA
INRUSH CURRENT	20-140 VAC 2.4 A 140-250 VAC 20-250 VDC
POWER-ON EFFECT PROTECTION	INCORPORATED
PROTECTION AGAINST TRANSIENTS	<20 kV <1 ms <0.5 J
OPERATING TEMPERATURE	-25°C to +70°C (-13°F to +158°F)
ENCLOSURE	MEETS NEMA 1, 3, 4, 6, 13 AND IEC IP67
SHOCK	30 g, 11 ms
VIBRATION	10 Hz to 55 Hz, 1 mm AMPLITUDE (ON ALL 3 PLANES)
LED FUNCTION	GREEN: POWER ON GREEN FLASHING: SHORT-CIRCUIT OR OVERLOAD PROTECTION RED: OUTPUT ENERGIZED
SENSING RANGE	2 mm = .079" (NOMINAL)
SWITCHING FREQUENCY	30 Hz
REPEATABILITY	—
OPERATING PRESSURE	1500 PSI (MAX. APPLIED 3000 PSI)
SHIELDED	YES
RESPONSE TIME	15 ms MAX.
COLOR CODE	RED
AGENCY COMPLIANCES	EB6R1 UL: E118717(N) 11/15/88 CSA: LR 57940 4/18/92



RELATED DOCUMENTS	3RD ANGLE PROJECTION	THIS DRAWING IS PROPERTY OF TURCK INC. USE OF THIS DOCUMENT WITHOUT WRITTEN PERMISSION IS PROHIBITED.		<b>TURCK INC</b> High Technology Sensors and Automation Controls	
1. 2. 3. 4.		DRAWN	DATE 12/10/88	DESCRIPTION BI 2-CRS524-ADZ30X2-B1131 /S34 UL	
MATERIAL	TOLERANCES UNLESS OTHERWISE SPECIFIED	DATE	SCALE NONE	IDENTIFICATION NO.	
BLACK ZINC	.X ±0.02 .XX ±0.01 .XXX ±0.005 ANGLES ±1° ALL MILLIMETER DIMENSIONS ARE REFERENCE ONLY	UNIT OF MEASUREMENT <b>INCH [ MILLIMETER ]</b>	FILE: T4272093	T4272093	
X UPDATE TO CURRENT TITLE BLOCK	RDS 01/21/03	DO NOT SCALE THIS DRAWING	FILE: T4272093	SHEET 1 OF 1	
REV DESCRIPTION	BY DATE EDO NO.				