

Summary of Changes

This publication contains new and updated information as indicated in the following table.

Topic	Page
Added product selection, accessories, and modifications to all products	throughout

836 Pressure Controls

- Operating ranges from 30 in. Hg vacuum...900 psi
- Independently adjustable range and differential
- Copper alloy and stainless steel bellows
- 7/16-20 S.A.E. and 1/4 in. N.P.T.F. connections
- Variety of contact blocks available
- Open Type, Type 1, Type 4 & 13, Type 4X, and Type 7 & 9 and 4 & 13 combination enclosures

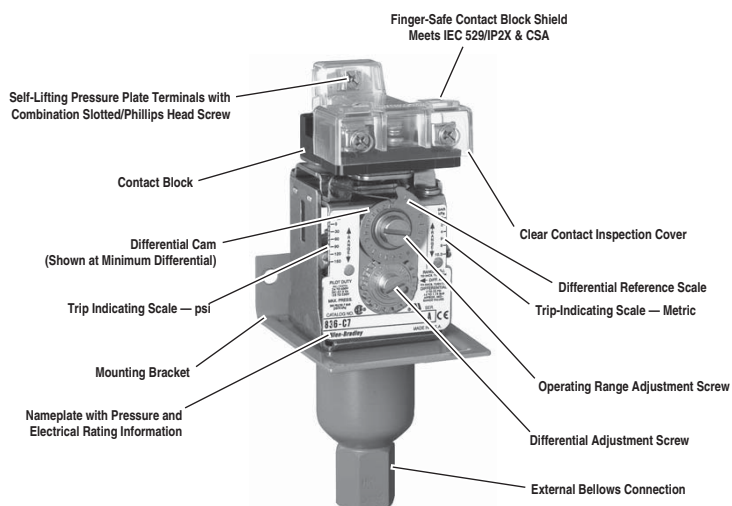

Bulletin 836 Pressure Controls are designed for general industrial use to control and detect pressure. Allen-Bradley Bulletin 836 Pressure Controls can be used in pneumatic and hydraulic systems. Pressure controls use copper alloy or stainless steel bellows. The design and high-quality components provide long life operation with air, water, oil, noncorrosive liquids, vapors, gases, and some corrosive liquids and gases.

Pressure controls feature snap action precision switches equipped with silver contacts. The straight in-line and relatively friction-free construction provides accurate and consistent operation regardless of the angle at which the controls are mounted. Pressure controls are designed for easy adjustment of both trip and reset pressures.





Allen-Bradley Bulletin 836 Pressure Controls are used in many types of industries and applications. They can be used to control pneumatic systems, maintaining preset pressures between two values. Pressure controls can be used to detect overpressures of gases or liquids to help protect machines, processes, and personnel. They can also be used to detect low pressures to help protect equipment from loss of coolants and lubrication.

Bulletin 836 Pressure Controls are offered in various styles to meet a wide range of applications. The devices are available in Type 1, 4 & 13, 4X, 7 & 9 and 4 & 13 combined and open type without enclosure for panel mounting. Pressure controls have a wide variety of contact modifications to meet most control circuit requirements. The controls have adjustable pressure ranges from 30 in. Hg vacuum...900 psi with corresponding differentials. Accessories and modifications are available to tailor the device to meet most application requirements.

Applications

- Air compressors
- Compressed air monitor systems
- Liquid level control
- Vacuum transfer systems
- High-pressure alert
- Low-pressure alert
- Monitor low and high pressure

Product Overview

Type	Description				
Style A — Small Size, Internal Copper Alloy Bellows					
	<ul style="list-style-type: none"> • Independently adjustable range and differential • 7/16-20 SAE flare for 1/4 in. copper tubing connection • Adjustable operating range — 30 in. Hg vacuum . . . 375 psi • Maximum line pressure — up to 750 psi • Occasional surge pressure — up to 850 psi 				
Style C — Wider Ranges, External Bellows					
	<p>Style C</p> <ul style="list-style-type: none"> • Independently adjustable range and differential • 1/4 in N.P.T.F. internal pipe connection • 3/8 in N.P.S.F. internal pipe connection (836-C1 and 836-C1A only) <p>Copper Alloy Bellows</p> <ul style="list-style-type: none"> • Adjustable operating range — 30 in. Hg vacuum . . . 900 psi • Maximum line pressure — up to 1300 psi • Occasional surge pressure — up to 1600 psi <p>Type 316 Stainless Steel Bellows</p> <ul style="list-style-type: none"> • Adjustable operating range — 30 in. Hg vacuum . . . 375 psi • Maximum line pressure — up to 650 psi • Occasional surge pressure — up to 650 psi 				
Refrigeration Controls					
	<p>Style H</p> <ul style="list-style-type: none"> • High-pressure refrigeration controls <p>Style L</p> <ul style="list-style-type: none"> • Low-pressure refrigeration controls <p>Style P</p> <ul style="list-style-type: none"> • High-pressure definite purpose controls 				
Standards Compliance					
<ul style="list-style-type: none"> • UL 508 • UL 698 (Haz. Loc.) • UL 1604 (Haz. Loc.) • CSA 22.2 No. 14 • NEMA ICS-2 • IEC 529/IP2X 	File and Guide Numbers				
Certifications		UL	CSA		
		File Number	Guide Number	File Number	Class
		E14842 E53048 (Haz. Loc.) ⁽¹⁾	NKPZ, NOWT	LR1234, LR11924 (Haz. Loc.)	3211-03 3218-05

(1) Hazardous Location Enclosure not CE compliant. All other enclosed devices are CE-compliant

Technical Terms

Term	Definition
Adjustable operating range	Total span within which the contacts can be adjusted to trip and reset.
Trip setting	Higher pressure setting at which value the contacts transfer from their normal state to a changed state.
Reset setting	Lower pressure setting at which value the contacts return to their normal state.
Adjustable differential	Difference between the trip and reset values.
Minimum differential	When the differential is set to the lowest pressure difference between trip and reset.
Maximum differential	When the differential is set to the widest pressure difference between trip and reset.
Maximum occasional surge pressure	Maximum surge pressure that can be applied to the actuator. Surges or transients can occur during startup and shutdown of a machine or system. Expressed in milliseconds, complex electronic instrumentation is required to measure the varying amplitude, frequency, and duration of this wave form. Extreme surges that occur approximately eight times in a 24-hour period are negligible.
Maximum line pressure	Maximum sustained pressure that can be applied to the bellows without permanent damage. The control should not be cycled at this pressure.
Positive pressure	Any pressure more than 0 psi. See Figure 2
Trip setting	Increasing pressure setting when contacts change state.
Reset setting	Decreasing pressure setting when contacts return to their normal state.
Vacuum (negative pressure)	Any pressure less than 0 psi, inches of Hg vacuum. See Figure 2
Trip setting	Decreasing vacuum setting when contacts change state.
Reset setting	Increasing vacuum setting when contacts return to their normal state.
psi	Pounds per square inch. Devices that are listed are in gauge pressure units that use atmospheric pressure as a reference. Atmospheric pressure at sea level is approximately 14.7 psi or 30 in. Hg.
Operating range adjustment screw	This screw is used to adjust the trip setting by varying the force of the main spring.
Differential adjustment screw	This screw is used to adjust reset setting by varying the force of the differential blade spring.
Pressure media	There are many types of pressure media that are controlled. Examples include air, water, hydraulic fluids, and other types of gases and liquids. The type of media and maximum system pressure will determine the type of actuator that is used for the pressure control application. See Pressure Control Selection on page 8 .
Pressure connection	Common types of pressure connections that are used in control systems are 1/4 in. and 3/8 in. internal pipe threads, and 7/16 in. — 20 SAE copper tubing.
Contact configuration	There are many types of contact configurations available. Bulletin 836 Style A and C pressure controls offer a wide variety of contact configurations for both automatic operation and manual reset. See Modifications on page 13

Figure 1 - Technical Terms Illustration

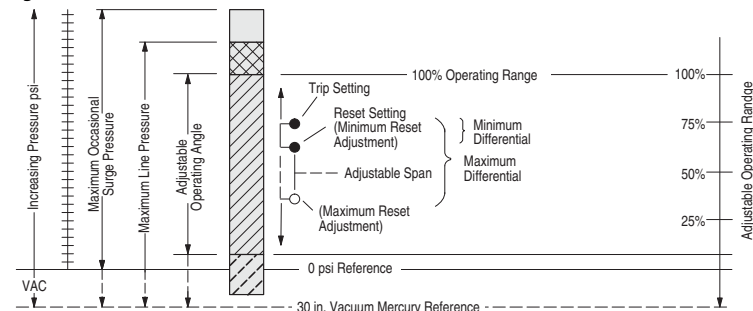
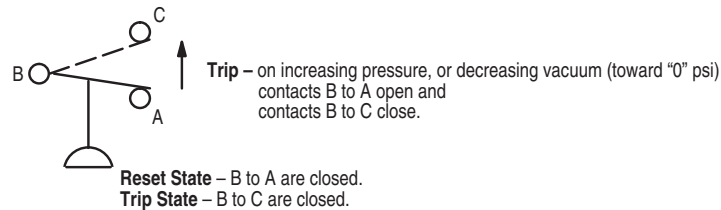

Figure 2 - Positive Pressure or Vacuum



Operation

Bulletin 836 Pressure Controls are designed to open or close electrical circuits in response to changes in pneumatic (air or gas) or hydraulic (water or oil) pressure. [Figure 3](#) is a simplified drawing of a pressure control.

The system pressure is connected to the control at the pressure connection. The system pressure is applied directly to the bellows. As pressure rises, the bellows exert force on the main spring. When the threshold force of the main spring is overcome, it transfers the motion to the contact block, causing the contacts to actuate — this is referred to as the trip setting. As pressure decreases, the main spring will retract, causing the secondary differential blade spring to activate and return the contacts to their normal state — this is referred to as reset setting.

Varying the force of the main spring (by turning the operating range adjustment screw) determines where the contacts will trip. Varying the force of the secondary differential blade spring (by turning the differential adjustment screw) determines where the contacts will reset.

Figure 3 - Basic Mechanical Structure

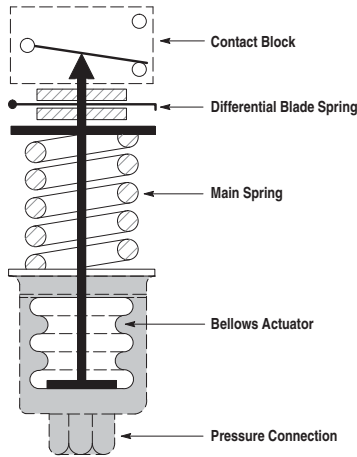

Applications for Control

Pressure controls can be used to either control or monitor a machine or process. [Figure 4](#) shows a typical control application. Here, pressure is controlled within predetermined high and low values. [Figure 5](#) shows a typical monitoring application. Here, pressure is monitored between a high and low value, signaling when a preset limit has been exceeded.

Figure 4 - Typical Control Application

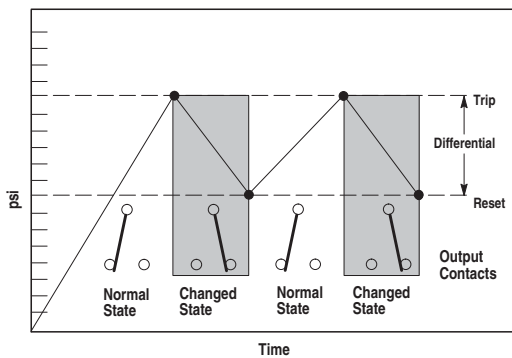
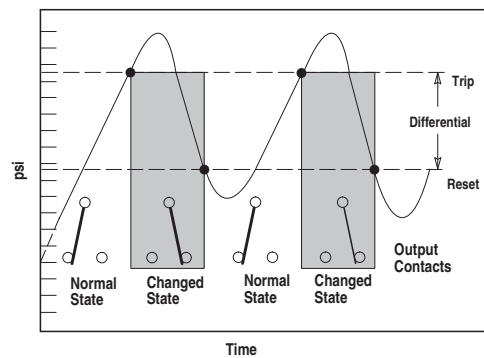

Figure 5 - Typical Monitoring Application



Control Settings

Allen-Bradley controls are designed for ease of setting to help minimize installation time. Standard controls that are shipped from the factory are set at the maximum operating range and minimum differential. By following this simple two-step process, the control can be set to the specific requirements for each application. See [Figure 6](#).

1. Adjust the trip setting.

The trip setting is achieved by turning the operating range adjustment screw. Turn the range screw counterclockwise to lower the trip setting, or clockwise to raise the trip setting. The approximate trip setting is shown on the indicating scale.

Turning the operating range adjustment screw will change both the trip and reset settings in equal increments.

2. Adjust the reset setting.

The reset setting is achieved by turning the differential adjustment screw counterclockwise to increase the differential, or clockwise to decrease the differential.

IMPORTANT Adjusting the differential has little or no effect upon the trip setting.

Figure 6 - Trip and reset adjustment

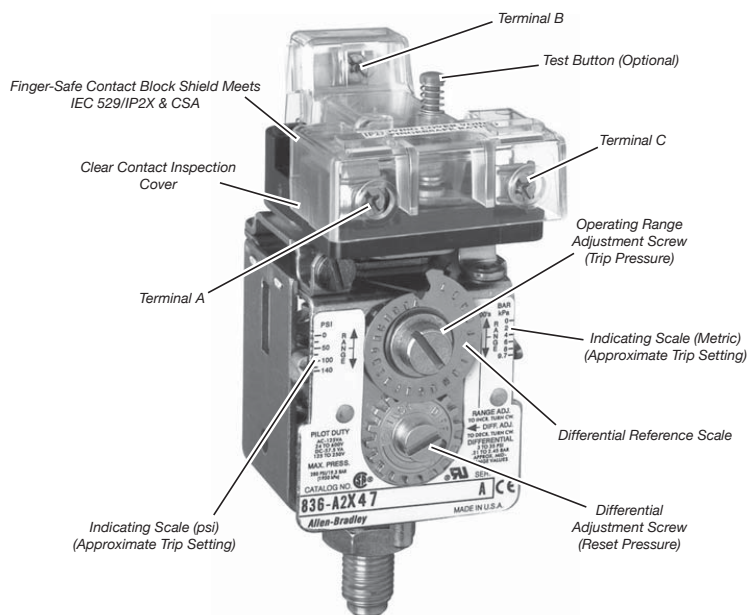

Repeat Accuracy and Mechanical Life

The design and construction of Bulletin 836 Styles A and C controls provide a typical repeat accuracy of $\pm 0.5\%$ or better. Repeat accuracy is based on percent of maximum range, evaluated from test data, and calculated using the formula per ICS 2-225 standards.

Repeat accuracy and mechanical life of bellows type controls is graphically illustrated in [Figure 7 on page 7](#). For general applications, controls selected where the contacts operate between 30...80% of the operating range and where the maximum line and surge pressures do not exceed the specified values will provide excellent life and repeat accuracy. For more specific applications, it is important to note that the controls are designed to operate below or above these values. However, there can be a small trade-off between the factors of repeat accuracy and mechanical life.

Figure 7 - Repeat accuracy versus mechanical life graph

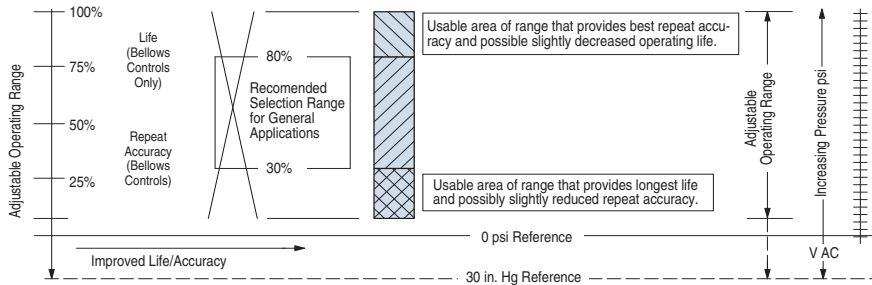

Standard Contacts	
Snap action contact operation	Contact blocks are single-pole, double-throw and can be wired to open or close on increasing or decreasing pressures.
Non-inductive ratings	5 A, 240V
	3 A, 600V
Control circuit ratings	AC - 125VA, 24...600V
	DC - 57.5VA, 115...230V

Figure 8 - Standard Contact Wiring Configurations, Single Pole Double Throw

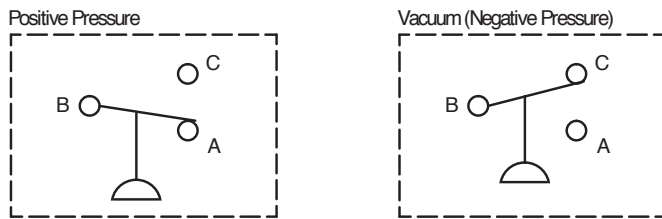

IMPORTANT NEMA does not rate contacts to switch low voltage and current. Bulletin 836 Styles A and C Pressure Controls are supplied with silver contacts. The devices are designed to deliver high-force snap action to the contacts. This provides exceptional contact fidelity at 24V DC I/O card current level entry when the control is protected in a suitable enclosure for the surrounding environment.

Special Controls

- Many unlisted catalog modifications and complete devices are available for specific and OEM applications.
- Special controls and modification service is available to meet many applications unique to the OEM market.
- Please contact your local Rockwell Automation sales office or Allen-Bradley distributor for assistance with specific modified controls and accessories.

Temperature Range

- Temperature range at +32 °F (0 °C) or below is based on the absence of freezing moisture, water, or other fluids that can solidify and impede operation of the control. Temperature ratings are as follows:
 - Operating: -22... +150 °F (-30...+66 °C)
 - Storage: -22...+200 °F (-30...+93 °C)

Factory-Set Pressure Controls

Rockwell Automation will factory set pressure control values to customer-specified values only if a Cat. No. 836-C device is ordered. Catalog numbers that are ordered without the "C" suffix are set at the maximum operating range and minimum differential. See [Ordering Factory-Set Pressure Controls on page 15](#).

Pressure Control Selection

The selection table below is an overview of the three types of Allen-Bradley Bulletin 836 Pressure Controls. Each type of control is suitable for use on many types of applications. Pressure ranges, pressure connections, enclosure types, and the compatibility of the actuator with different types of pressure media are given to assist in the selection of which type of control to use.

Style	836 Style A		836 Style C	
Actuator Type	Internal Bellows, Copper Alloy		External Bellows, Copper Alloy	External Bellows, Stainless Steel Type 316
Adjustable Operating Ranges	30 in. Hg Vacuum . . . 375 psi		30 in. Hg Vacuum . . . 900 psi	30 in. Hg Vacuum . . . 375 psi
Adjustable Differentials	2 . . . 95 psi		0.2 . . . 125 psi	0.4 . . . 80 psi
Maximum Line Pressures	up to 750 psi		up to 1300 psi	up to 650 psi
Occasional Surge Pressures	up to 850 psi		up to 1600 psi	up to 650 psi
Pressure Media				
Air	•		•	•
Water	•		•	•
Hydraulic Fluids	•		•	•
Liquids	Corrosive ⁽¹⁾			•
	Noncorrosive	•	•	•
Gases	Corrosive ⁽²⁾			•
	Noncorrosive	•	•	•
Enclosures				
Open Type	•		•	•
Type 1	•		•	•
Type 4 & 13	•		•	•
Type 4X			•	•
Type 7 & 9 and 4 & 13	•		•	•
Pipe Connections				
Pressure Connection	7/16 in.-20 SAE Flare for 1/4 in. Copper Tubing		1/4 in. N.P.T.F. Internal Pipe Thread or 3/8 in. N.P.S.F. Internal Pipe connection (836-C1 and 836-C1A only)	1/4 in. N.P.T.F. Internal Pipe Thread

(1) Corrosive liquids compatible with Type 316 Stainless Steel.

(2) Corrosive gases compatible with Type 316 Stainless Steel.

Ordering Information

When ordering Bulletin 836 Pressure Controls, consider the following:

- Device style
- Occasional surge pressure
- Adjustable operating range
- Pressure media
- Adjustable differential
- Enclosure type
- Maximum line pressure
- Pressure connection

How to Order

1. Select Basic Device	2. Modifications	3. Accessories	3. Factory Options
Select a catalog number for the basic device. See Product Selection on page 10	If necessary, add one or more appropriate modification suffix codes to the catalog number of the basic device. See Modifications on page 13	If necessary, select appropriate accessories. See Accessories on page 14	Factory-set pressure controls. See Ordering Factory-Set Pressure Controls on page 15

Catalog Number Explanation

836	-	A	1	A	X2	C
		a	Pressure specifications	b	Modifications Add suffix codes in descending order whenever possible. See Modifications on page 13	c
a		b		c		
Style of Device		Enclosure Type		Modifications		
Code	Description	Code	Description	Code	Description	
A	Internal bellows	A	Type 1	blank	Max. range/ min. differential	
C	External bellows	E	Type 7 & 9 and 4 & 13 Combined Metallic (Aluminum)	C	Customer specified trip/reset setting ⁽¹⁾	
		J	Type 4 & 13 Metallic (Aluminum)			
		S	Type 4X Non-Metallic			
		blank	Without enclosure			

(1) The requested trip/reset setting must be within the adjustable operating and differential ranges for the pre-configured product, refer to Product Selection.

Conversion Factors (Rounded)

psi x (multiplied by factor below) ⁽¹⁾	Equals	psi x (multiplied by factor below)	Equals
703.1	mm/H ₂ O	0.0689	bar
27.68	in. H ₂ O	68.95	mbar
51.71	mm/Hg	6895	Pa
2.036	in. Hg	6.895	kPa
0.0703	kg/cm ²		

(1) psi — pounds per square inch (gauge) H₂O at 39.2°F/Hg at 32 °F

Product Selection

Style A Internal Bellows⁽¹⁾ — Copper Alloy⁽²⁾ Bellows With 7/16 in. — 20 SAE Flare for 1/4 in. Copper Tubing Connection

Figure 9 - Style A Internal Bellows —Copper Alloy, Type 1



Figure 10 - Style A Internal Bellows —Copper Alloy, Type 4 & 13



Pressure Specifications				Enclosure Type			
Adjustable Operating Range [in. Hg Vacuum...psi] ⁽¹⁾	Adjustable Differential [psi] (Approximate Mid-Range Values) ⁽²⁾	Maximum psi		Open Type (Without Enclosure)	Type 1	Type 4 & 13	Type 7 & 9 and 4 & 13 ⁽⁴⁾
		Line Pressure	Occasional Surge Pressure ⁽³⁾	Cat. No.	Cat. No.	Cat. No.	Cat. No.
30 in. Vacuum...75	2...20	160	160	836-A1	836-A1A	836-A1J	836-A1E
6...140	3...35	280	340	836-A2	836-A2A	836-A2J	836-A2E
12...250	6...65	500	600	836-A3	836-A3A	836-A3J	836-A3E
16...375	8...95	750	850	836-A4	836-A4A	836-A4J	836-A4E

- (1) For applications where settings approach 0 psi, select a control that has an adjustable range that goes into vacuum.
- (2) To determine differential in inches of mercury vacuum multiply value in table by 2.036 (or approximately 2).
- (3) Transients (pulses) can occur in a system prior to reaching a steady-state condition. Surge pressures within published values that are generated during startup or shutdown of a machine or system, not exceeding eight times in a 24-hour period, are negligible.
- (4) The combined Type 7 & 9 and 4 & 13 Hazardous Gas and Dust service enclosure is supplied with a special gasket and O-ring seal to diminish/exclude moisture, fluids, and dust from entering the enclosure. Enclosures rated 7 & 9 only are not designed to restrict moisture from entering the enclosure, which is common to outdoor service. Enclosure is rated for the following environments: CLASS I: Groups C and D, CLASS II: Groups E, F, and G, and CLASS III.

(1) Standard pressure controls shipped from the factory are set at the maximum operating range and minimum differential. For more information on standard pressure control settings and customer-specified pressure control settings, consult your local Rockwell Automation sales office or Allen-Bradley distributor.
 (2) Copper alloy bellows can be used on water or air, and other liquids or gases not corrosive to this alloy.

Style C External Bellows — Copper Alloy Bellows With 1/4 in. N.P.T.F. Internal Pipe Connection

Figure 11 - Style C External Bellows —Copper Alloy, Type 1 With Pilot Light Option



Figure 12 - Style C External Bellows —Copper Alloy, Type 4 & 13



Pressure Specifications				Enclosure Type				
Adjustable Operating Range [in. Hg Vacuum...psi]	Adjustable Differential [psi] (Approximate Mid-Range Values) ⁽²⁾	Maximum psi		Open Type (Without Enclosure)	Type 1	Type 4 & 13	Type 4X	Type 7 & 9 and 4 & 13 ⁽⁴⁾
		Line Pressure	Occasional Surge Pressure ⁽³⁾	Cat. No.	Cat. No.	Cat. No.	Cat. No.	Cat. No.
12 in. Vacuum...8 ⁽¹⁾	0.2...2.5	25	30	836-C1	836-C1A	—	—	—
30 in. Vacuum...10	0.4...6	65	75	836-C2	836-C2A	836-C2J	836-C2S	836-C2E
0.8...30	0.5...6	80	80	836-C3	836-C3A	836-C3J	836-C3S	836-C3E
30 in. Vacuum...45	1...12	175	190	836-C4	836-C4A	836-C4J	836-C4S	836-C4E
2...80	1...12	190	210	836-C5	836-C5A	836-C5J	836-C5S	836-C5E
30 in. Vacuum...100	2...25	300	375	836-C6	836-C6A	836-C6J	836-C6S	836-C6E
4...150	2.5...25	300	375	836-C7	836-C7A	836-C7J	836-C7S	836-C7E
6...250	4...45	500	650	836-C8	836-C8A	836-C8J	836-C8S	836-C8E
35...375	6...80	900	1200	836-C9	836-C9A	836-C9J	836-C9S	836-C9E
50...500	12...115	1300	1600	836-C10	836-C10A	836-C10J	836-C10S	836-C10E
50...650	16...115	1300	1600	836-C11	836-C11A	836-C11J	836-C11S	836-C11E
200...900	25...115	1300	1600	836-C12	836-C12A	836-C12J	836-C12S	836-C12E

- (1) For applications where settings approach 0 psi, select a control that has an adjustable range that goes into vacuum.
- (2) To determine differential in inches of mercury vacuum multiply value in table by 2.036 (or approximately 2).
- (3) Transients (pulses) can occur in a system prior to reaching a steady-state condition. Surge pressures within published values that are generated during startup or shutdown of a machine or system, not exceeding eight times in a 24-hour period, are negligible.
- (4) The combined Type 7 & 9 and 4 & 13 Hazardous Gas and Dust service enclosure is supplied with special gasket and O-ring seal to diminish/exclude moisture, fluids, and dust from entering the enclosure. Enclosures rated 7 & 9 only are not designed to restrict moisture from entering the enclosure, which is common to outdoor service. Enclosure is rated for the following environments: CLASS I: Groups C and D, CLASS II: Groups E,F, and G, and CLASS III

Style C External Bellows — Type 316 Stainless Steel Bellows⁽¹⁾ With 1/4 in. N.P.T.F. Internal Pipe Connection

Standard pressure controls shipped from the factory are set at the maximum operating range and minimum differential. For more information on standard pressure control settings and customer-specified pressure control settings, consult your local Rockwell Automation sales office or Allen-Bradley distributor.

Figure 13 - Style C External Bellows — Type 4X Glass Reinforced Polyester Enclosure



Figure 14 - Style C External Bellows — Stainless Steel, Type 7 & 9 and 4 & 13 Combined



Pressure Specifications				Enclosure Type				
Adjustable Operating Range [in. Hg Vacuum...psi] ⁽¹⁾	Adjustable Differential [psi] (Approximate Mid-Range Values)	Maximum psi		Open Type (Without Enclosure)	Type 1	Type 4 & 13	Type 4X	Type 7 & 9 and 4 & 13 ⁽²⁾
		Line Pressure	Occasional Surge Pressure\$	Cat. No.	Cat. No.	Cat. No.	Cat. No.	Cat. No.
30 in. Vacuum...10	0.4...6	65	65	836-C60	836-C60A	836-C60J	836-C60S	836-C60E
0.8...30	0.4...6	65	65	836-C61	836-C61A	836-C61J	836-C61S	836-C61E
30 in. Vacuum...100	2...25	270	270	836-C62	836-C62A	836-C62J	836-C62S	836-C62E
4...150	2.5...25	270	270	836-C63	836-C63A	836-C63J	836-C63S	836-C63E
6...250	4...45	450	450	836-C64	836-C64A	836-C64J	836-C64S	836-C64E
35...375	8...80	650	650	836-C65	836-C65A	836-C65J	836-C65S	836-C65E

(1) For applications where settings approach 0 psi, select a control that has an adjustable range that goes into vacuum.
 (2) The combined Type 7 & 9 and 4 & 13 Hazardous Gas and Dust service enclosure is supplied with special gasket and O-ring seal to diminish/exclude moisture, fluids, and dust from entering the enclosure. Enclosures rated 7 & 9 only are not designed to restrict moisture from entering the enclosure, which is common to outdoor service. Enclosure is rated for the following environments: CLASS I: Groups C and D, CLASS II: Groups E,F, and G, and CLASS III

(1) Type 316 stainless steel bellows are available fore more corrosive liquids or gases.

Modifications

Modifications are ordered by adding the appropriate modification suffix code to the catalog number of the basic device. Add suffix codes to the catalog number in descending order (highest number first).

Description		Suffix Code
Contact Blocks		
Standard Contact Blocks, Automatic Operation		
Single pole, double throw, snap action ⁽¹⁾⁽²⁾	Supplied when a contact block suffix is not added to the catalog number. Control Circuit Rating: See Specifications on Standard Contacts	—
Single pole, double throw, slow-acting contact with no snap action ⁽¹⁾⁽²⁾	Contacts close on rise and close on fall with an open circuit between contact closures. Control Circuit Rating: AC-125VA, 24...250V	X171
Single pole, single throw, normally open, closes on rise ⁽¹⁾⁽²⁾	0.5 Hp, 115V AC 1 HP, 230V AC Control Circuit Rating: AC-125 VA, 24...110V AC-345 VA, 110...600V DC-57.5 VA, 110...250V	X221
Single pole, single throw, normally closed, opens on rise ⁽¹⁾⁽²⁾		X231
Single pole, single throw, normally open, closes on rise ⁽¹⁾⁽²⁾	1 Hp, 115V AC 1.5 Hp, 230V AC Control Circuit Rating: AC-600 VA, 110...600V DC-57.5 VA, 110...250V	X321
Single pole, single throw, normally closed, opens on rise ⁽¹⁾⁽²⁾		X331
External Manual Reset		
Non-inductive: 5 A, 240V 3 A, 600V Control Circuit Rating: AC-125 VA, 24...600V DC-57.5 VA, 115...230V (Not available in Type 4X Enclosures) ⁽¹⁾⁽³⁾		
Single-pole single-throw, normally open — contacts open at a predetermined setting on fall and remain open until system is restored to normal run conditions, at which time contacts can be manually reset.		X140
Single pole single throw, normally closed — contacts open on rise and remain open until system is restored to normal run conditions, at which time contacts can be manually reset.		X150
Single pole double throw, one contact normally closed — contact opens on rise and remains open until system is restored to normal run conditions, at which time contact can be manually reset. A second contact closes when the first contact opens.		X15A
Other Modifications		
Oxygen/Nitrous Oxide Service - Bellows and fittings are specially prepared for oxygen and nitrous oxide service. The devices are tested with pure oxygen, bellows are plugged for protection from contamination, and a tag warning against contamination is applied.		X2
Tamper-Resistant Adjustment - Range and differential adjustment screws are designed so that after a setting has been applied to the control, the adjustment screws can be broken off with pliers. Note: The "break-off" adjustment screws will not be broken off unless a factory setting is given and the order specifies "Break-off Adjustment Screws". See Ordering Factory-Set Pressure Controls on page 15		X4
Pilot Lights ⁽⁴⁾		
LED Pilot Light, 120V AC	Contact modified industrial controls team to select LED color and to configure catalog number.	—
Red LED Pilot Light, 24V DC - A high intensity LED 24V DC pilot light is available to meet the requirements of the automotive, machine tool builders and other industries. The current rating is 22 mA and can be wired for ON or OFF operation.		X15
Green LED Pilot Light, 24V DC - A high intensity LED 24V DC pilot light is available to meet the requirements of the automotive, machine tool builders and other industries. The current rating is 22 mA and can be wired for ON or OFF operation.		X18

(1) Contact blocks are not available for field conversion or replacement. Trip pressure-indicating scales are supplied on controls with standard contact block.

(2) Minimum specified differential value approximately doubles.

(3) Manual reset devices cannot be supplied with an adjustable differential. Inherent differential is approximately three times the differential of the corresponding adjustable differential control. Available only for replacement of complete open type control in an existing Type 1 or 4 & 13 enclosure. Replacement in a Type 7 & 9 enclosure is not available because it would void UL and CSA. Type 7 & 9 enclosures for manual reset devices are not also rated Type 4 & 13.

(4) Not available on combined Type 7 & 9 and 4 & 13, Type 4X, and manual reset devices.

IMPORTANT NEMA does not rate contacts to switch low voltage and current. Bulletin 836 Styles A and C Pressure Controls are supplied with silver contacts. The devices are designed to deliver high-force, snap-action to the contacts. This provides exceptional contact fidelity at 24V DC I/O card current level entry when the control is protected in a suitable enclosure for the surrounding environment.

Accessories

Accessories are ordered as separate catalog numbers. Select the required accessories from the following tables.

Description		Cat. No.	
Pipe Adapter	1/4 in. male pipe adapter with copper seating washer for Style A only.	836-N1	
Contact Block Replacement Kit	Kit consists of a standard contact block and instructions.	836-N2	
Fingersafe Contact Block Cover	Clear contact block cover provides IP2X fingersafe protection.	41162-908-01	
Hardware Kits for Mounting Open Type Controls in Special Enclosures	Hardware kits for mounting open type controls in special enclosures allow ease of connecting pressure lines to the enclosure. For use with Type 1 and Type 4 & 13 enclosures with wall thickness up to 0.25 in. (6.35 mm).	Style A Controls, Open type controls, Plated steel	836-N5
		Style C Controls, Open type controls, Brass	836-N8
		Style C Controls, Stainless steel	836-N10
Angle Mounting Brackets	For mounting one or two open type Bulletin 836 Style A Pressure Controls or Bulletin 837 Temperature Controls on an enclosure mounting plate.	Single bracket	836-N11
		Dual mounting bracket	836-N12
Isolation Traps, Steam and/or Corrosive Media Applications	An isolation trap is available for high-temperature media applications from 150 . . 600 °F or corrosive applications compatible with Type 316 stainless steel tubing and fittings. The isolation coil is inserted between the bellows of the pressure control and the elevated temperature line of the system. The isolation trap will fill with condensed water or can be filled with water or suitable fluid when installed. A silicone buffer fluid is available in a convenient dispenser. Copper alloy lower and higher pressure range bellows can be applied to many applications using the isolation trap. The silicone buffer fluid is used to isolate many corrosive substances from coming in contact with the bellows. The isolation trap is rated at 3000 psi working pressure. Not available for piston-type controls	Isolation trap with two 1/4 in. male pipe fittings	836-N25
		Isolation trap with one 1/4 in. male and one 1/4 in. female pipe fitting	836-N26
		2 oz. of buffer fluid to fill bellows and tubing	836-N27
External Fixed Pulsation Snubbers	Controls are supplied as standard with an internal pulsation snubber. However, a control that is properly selected and used within the adjustable range values yet having a short bellows life is a good indication of the presence of extreme surge pressures. External fixed pulsation snubbers are available to provide additional dampening when extreme pulsations or surges are present. Recommended if more than eight line surges occur in a 24-hr. time period.	Style A Controls	836-N6
		Style C Controls	836-N7
Selectable Element Pulsation Snubbers	Controls are supplied as standard with an internal pulsation snubber. However, a control that is properly selected and used within the adjustable range values, yet having a short bellows life, is a good indication of the presence of extreme surge pressures. Selectable element pulsation snubbers are supplied with five different elements to provide a selectable balance between maximizing pressure control life and minimizing control response time. Pulsation snubbers are supplied with the mid-range element already mounted and four other color-coded porosity elements included in the package.	Style C Controls	836-N40

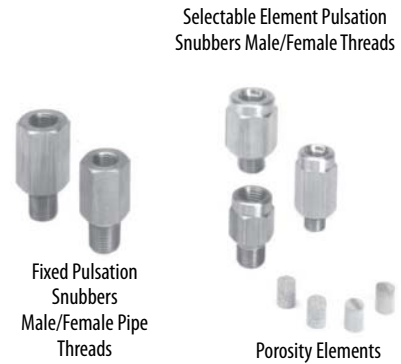

Figure 16 - Isolation Trap and Silicone Buffer Fluid

Figure 15 - Selectable Pulsation Snubber Porosity Elements

Description	Recommended Type of Service ⁽¹⁾	Color Code	Porosity	
Elements are color-coded on the ends for easy identification. Elements are available in five different porosities for a wide range of applications.	Viscous fluids (over 500 SSU)	None	Coarser	
	Medium type oils (225...500 SSU)	Black	↕	
	Water and light oils (30...225 SSU)	Brown		
	Low viscosity fluids (under 30 SSU)	Green		
	Air and other gases	Red		Finer
	One of each of the above	—		Assorted

(1) SSU= Saybolt Seconds Universal — units of viscosity measurement.



Ordering Factory-Set Pressure Controls

This section describes the factory-set pressure controls options.

Standard Product Offering

Standard pressure controls shipped from the factory are set at the maximum operating range and minimum differential. These settings vary for each pressure switch family depending on the combination of Style, Operator Type, and Pressure Specification configuration options. These pressure switches do not require a custom trip / reset setting characteristic. Customers still have the ability to set the operating range and differential in the field as long as they are within the limitation of switch.

Custom Product Offering (Customer-Specified Settings)

Pressure controls shipped from the factory can be set to customer-requested values as long as they are within the limitation of the switch. See Product Selection, and reference Adjustable Operating Range and Adjustable Differential values in the tables. These trip and reset ranges vary depending on the Style, Operator Type, and Pressure Specification configuration. These switches require a custom trip/reset setting characteristic. To request a pressure switch with customer specified trip and/or reset settings, order a pressure control catalog number ending with the “C” Custom Trip Reset Setting characteristic and include one of the following factory-set pressure control statements when the order is placed (within the Customer Review Request Notes field):

EXAMPLE Normally Closed (N.C.) contacts to open at * psi increasing pressure and close at * psi decreasing pressure.
—OR—
Normally Open (N.O.) contacts to close at * psi increasing pressure and open at * psi decreasing pressure.

If minimum differential is not critical and the inherent minimum differential satisfies the application, specify the factory setting as follows:

Normally Closed (N.C.) contacts to open at * psi increasing pressure. Minimum differential.
—OR—
Normally Open (N.O.) contacts to close at * psi increasing pressure. Minimum differential.

* Specify psi (pounds per square inch) or, in. Hg vacuum (inches of mercury vacuum)

When a specific factory setting is requested, the specific terminal connections must be specified — for example, N.O. or N.C. It must also be specified whether the contact operation is occurring on either increasing or decreasing pressure.

If not specified, settings tolerances will be as shown in table.

Setting Tolerances

Pressure Range	Tolerance
30 in. Hg Vac...0 psi	+/- 1 in. Hg Vac.
> 0...100 psi	+/- 1 psi
> 100...300 psi	+/- 2 psi
> 300...500 psi	+/- 5 psi
> 500...1000 psi	+/- 10 psi
> 1000...5000 psi	+/- 50 psi

Quality analog Test⁽¹⁾ gauges are used when applying requested factory settings to these rugged industrial-grade pressure controls. (Gauges are calibrated and the accuracy is traceable to National Bureau of Standards.)

The actual requested setting is applied to the control by reading the setpoint directly from the test gauge being used. However, traceable gauge tolerance variance between source and user, and possible severe shock during shipping and installation, can contribute to the factory settings deviating slightly from the specified values. Slight recalibration can easily be accomplished upon final installation to meet specific requirements for the more demanding applications. When installed, the controls will perform with a repeat accuracy as established in the paragraph on Repeat Accuracy and Mechanical Life entitled "Repeat Accuracy and Mechanical Life".

Special service is available to factory set controls on Digital Laboratory Instruments, up to 600 psi, when required for the more critical applications. An additional charge can be added for this service contingent upon setting tolerance and quantity.

Two Style A Controls In One Enclosure Bulletin 836 Style pressure controls which function independently can be mounted side by side in one Type 1 enclosure. This design is ideal for installations where two controls would ordinarily be mounted. Each dual unit can be a combination of a Style A pressure control and a bulb and capillary type temperature control. See respective product tables.

To order this arrangement, specify the two desired catalog numbers in their mounted position within the dual enclosure to form one catalog number. The list price is the sum of the two Type 1 enclosed devices.

IMPORTANT For more information on special controls, contact your local Rockwell Automation sales office or Allen-Bradley distributor.

Refrigeration Controls





Bulletin 836 Refrigeration Controls are similar to Bulletin 836 Style A Pressure Controls. However, refrigeration controls are constructed with additional pulsation dampening to filter out the severe pulsations generated by reciprocating refrigeration compressors. Pressure controls not supplied with the added snubber function can result in reduced bellows life. The reduced life results from pulsations severe enough to cause the bellows to "squeal" at the pump frequency or at the harmonic wave that is generated at specific pump loading demands. Refrigeration controls are supplied as standard with the pulsation snubber built into the stem of the bellows.

Allen-Bradley heavy-duty refrigeration controls have copper alloy bellows⁽²⁾ for use with noncorrosive refrigerants. The devices can be supplied as single Open Type devices or mounted in a Type 1 enclosure. Standard controls have 7/16 in. – 20 SAE male threads for a 45° flare fuel and lubricant fitting. Optionally, the refrigeration controls can be supplied with capillary tubing. The capillary terminates with 1/4 in. tubing, which is flared and supplied with a 7/16 in. – 20 female nut. To modify the standard pressure connection, add suffix "-36" (denotes 36 in.) to the catalog number. There is no price addition for changing to a capillary-type pressure connection. Example: Cat. No. 836-H11-XHC, modified for a 36 in. capillary connection, is Cat. No. 836-H11-XHC-36.

(1) Per ANSI B40.1 Grade 2 A (0.5% accuracy full scale), Grade 3 A (0.25% accuracy full scale).

(2) Copper alloy bellows can be used on water or air, and other liquids not corrosive to this alloy.

Product Overview

Photo	Description
Style H — High-Pressure Refrigeration Controls	
	<ul style="list-style-type: none"> • Copper alloy bellows with built-in pulsation snubber • 7/16 in. — 20 SAE male thread for 45° flare fitting • Adjustable operating range — 30...120 psi • Maximum line pressure — 450 psi • Occasional surge pressure — 800 psi • With capillary and flare connection
Style L — Low-Pressure Refrigeration Controls	
	<ul style="list-style-type: none"> • Copper alloy bellows with built-in pulsation snubber • With capillary and tubing connection • Adjustable operating range — 20 in. Hg vacuum...120 psi • Maximum line pressure — 220 psi
Style P — High-Pressure Definite-Purpose Refrigeration Controls	
	<ul style="list-style-type: none"> • Copper alloy bellows with built-in pulsation snubber • 7/16 in. — 20 SAE male thread for 45° flare fitting • Operating range — 30...700 psi • Line and occasional surge pressure — 800 psi • Fixed differential — 30 psi

Product Selection

Style H — High-Pressure Refrigeration Controls							
	Pressure Specifications				Enclosure Type		Contact Reference Number (See Contact Reference Number Table on page 18)
	Adjustable Operating Range [psi]	Adjustable Differential [psi] (Approximate Mid-Range Values)	Maximum Line Pressure [psi]	Limited Maximum Stop [psi]	Open Type Without Enclosure	Type 1	
					Cat. No.	Cat. No.	
30...270	30...80	600	—	836-H11-XHCS	836-H11-XHC	1	
50...450	40...100	800	—	836-H11-BLCS	836-H11-BLC	1	
100...285	40...90	600	285	836-H33-XKKS	836-H33-XKK	3	
200...425	40...90	800	425	836-H33-BLKS	836-H33-BLK	3	
125...280	60...120	800	280	836-H33-BKKS	836-H33-BKK	3	
Customer Specified, Factory Locked Operating Range With Fixed Differential of 30 psi							
75...350	35	800	—	836-H33-XNAS	836-H33-XNA	3	

Style L — Low-Pressure Refrigeration Controls - Copper Alloy Bellows



	Pressure Specifications			Enclosure Type		Contact Reference Number (See Contact Reference Number Table)
	Adjustable Operating Range [in. Hg Vacuum . . . psi]	Adjustable Differential [psi] (Approximate Mid-Range Values) ⁽¹⁾	Maximum Line Pressure [psi]	Open Type (Without Enclosure)	Type 1	
				Cat. No.	Cat. No.	
	20 in. Hg Vacuum . . . 120 psi	5 . . . 30	220	836-AL11-NKCS	836-AL11-NKC	
20 in. Hg Vacuum . . . 120 psi	9 . . . 50	220	836-AL32-NKCHS	836-AL32-NKCH	2	

(1) To determine differential in in. Hg vacuum, multiply the value in the table by 2.036 (or approximately 2).

Style P High-Pressure Definite Purpose—Copper Alloy Bellows

	Pressure Specifications				Enclosure Type		Contact Reference Number (See Contact Reference Number Table)
	Adjustable Operating Range [psi]	Fixed Differential [psi]	Maximum Line Pressure [psi]	Limited Maximum Stop [psi]	Open Type (Without Enclosure)	Type 1	
					Cat. No.	Cat. No.	
30 . . . 700	30	800	—	836-P11-ARBS	836-P11-ARB	1	

Contact Reference Number Table

Reference Number	Description	Symbol	Rating
1	Single pole double throw — automatically opens or closes on rise or fall		Non-inductive: 5 A, 240V . . . 3 A, 600V Control Circuit Rating: AC-125VA, 24 . . . 600V DC-57.5VA, 115 . . . 230V
2	Single pole single throw, normally open — closes on rise		1 Hp, 115V AC 1.5 Hp, 230V AC Control Circuit Rating: AC-600VA, 110 . . . 600V DC-57.5VA, 110 . . . 250V
3	Single pole single throw, normally closed — opens on rise		

Factory Options for Refrigeration Controls

It is common in the industry to supply a low-pressure Style L and a high-pressure Style H mounted in a common, dual Type 1 enclosure. This factory option can be supplied with the low-pressure control on the left and the high-pressure control on the right. To order, combine the two desired Type 1 catalog numbers into one number.

EXAMPLE Low-pressure control 836-AL11-NKC-36, plus high-pressure control 836-H11-BLC-36, becomes an 836-AL11-NKC-36/836-H11-BLC-36.



Two Style A Pressure Controls in One Type 1 Enclosure

Approximate Dimensions and Shipping Weights

Dimensions in inches (millimeters). Dimensions are not intended to be used for manufacturing purposes.

Style A

Figure 17 - Open Type

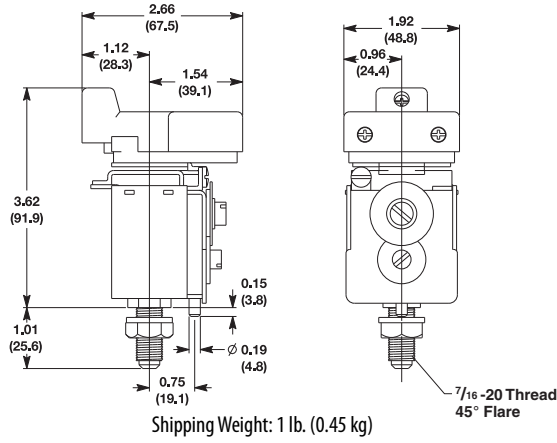

Figure 19 - Type 4 & 13

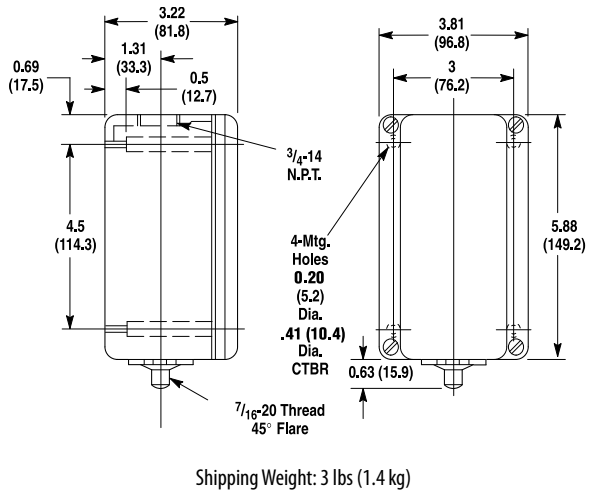

Figure 20 - Type 7 & 9 and 4 & 13

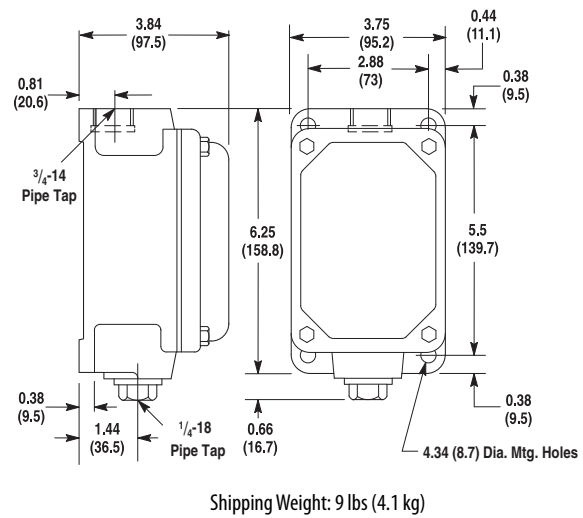

Figure 18 - Type 1

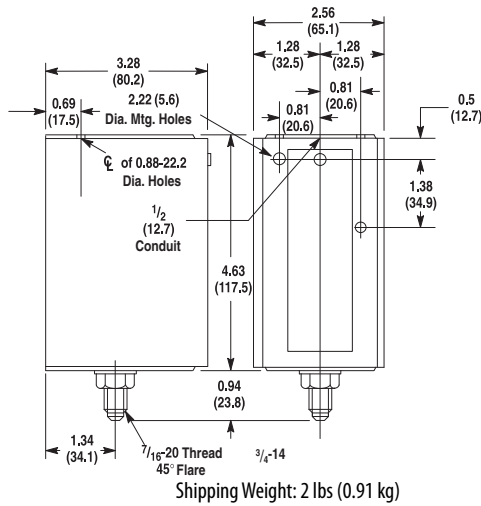

Figure 21 - Cat. No. 836-N1

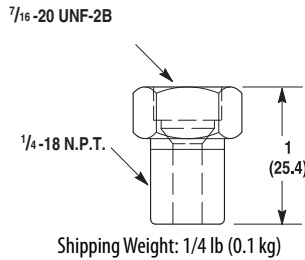
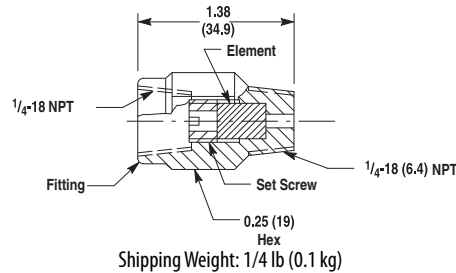
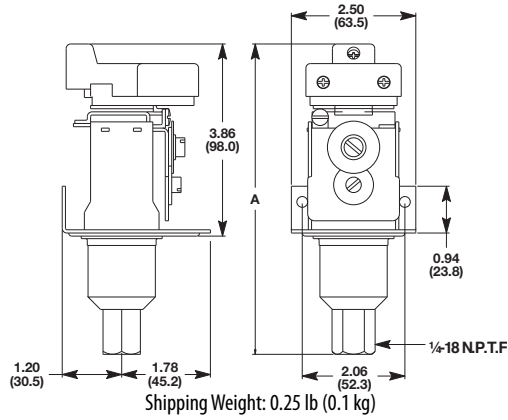

Figure 22 - Cat. No. 836-N40



Style C

Figure 23 - Cat. No. 836-C



Cat. No.	Dimension A in. (mm)
C2, C3, C60, C61	6.11 (155)
C4	5.99 (152)
C5, C64	5.94 (151)
C6, C62	6.29 (160)
C7, C63	6.24 (158)
C8, C9	5.56 (141)
C10, C11, C12, C65	5.78 (147)

Catalog Numbers 836-C1 and 836-C1A: Require a 2 in. swing radius from centerline of pressure connection. Mount control on 7/8 in. minimum spacers, 3/8-18 N.P.S.F. internal pipe connection.

Figure 24 - Type 1

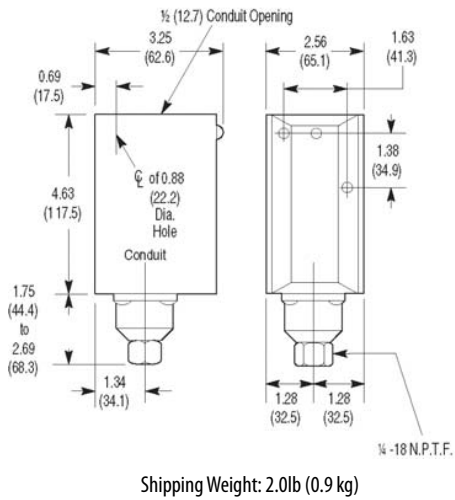

Figure 25 - Type 7 & 9 and 4 and 13

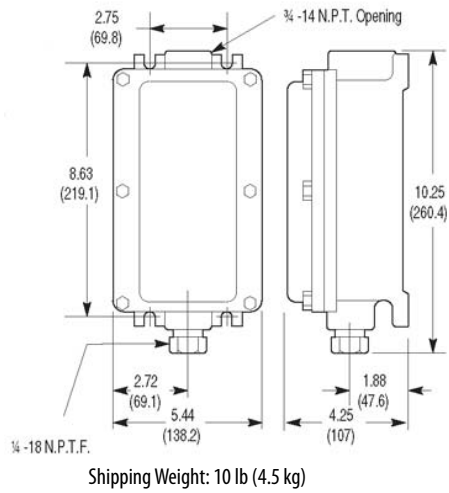

Figure 26 - Type 4 & 13

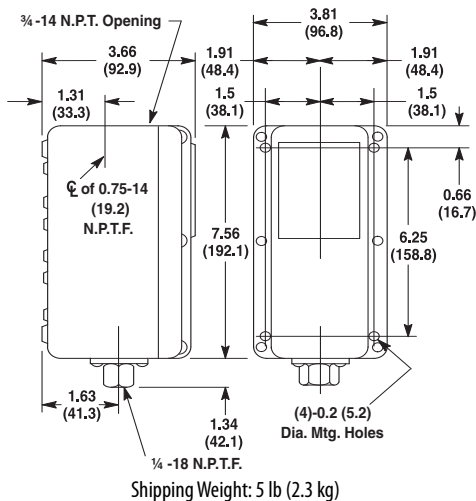

Figure 27 - Type 4X

