

Manual Motor Protectors and Magnetic Motor Protector Combinations System PKZ 2

UL / CSA / IEC / CE

Manual Motor Protectors, Motor Protector Combinations

UL/CSA Short-circuit current rating kA RMS sym @		Max. listed branch circuit protective fuse	Max. listed branch circuit protective breaker	Adjustable thermal range set to motor FLC	Adjustable trip setting current of magnetic trips	UL/CSA max. 3-phase HP ratings			
480 V AC	600 V AC					For single phase ratings and IEC kW rating, → page 08/065			
		A	A	A	A	200 V HP	230 V HP	460 V HP	575 V HP

Manual motor protector

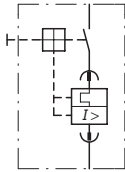
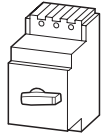

65	42	500	600	0,4 – 0,6	5 – 8	In this range, select motor protector in accordance with the motor nameplate full load current			
				0,6 – 1	8 – 14		1/2		1/2
				1 – 1,6	14 – 22		3/4		1
				1,6 – 2,4	20 – 35	1/2	1/2	1	1 1/2
				2,4 – 4	35 – 55	1	1	2	3
				4 – 6	50 – 80	1 1/2	1 1/2	3	5
				6 – 10	80 – 140	2	3	5	7 1/2
				10 – 16	130 – 220	3	5	10	10
				16 – 27	200 – 350	7 1/2	7 1/2	20	25
				24 – 32	275 – 425	10	10	20	30
				32 – 42	350 – 500	10	15	30	30

Magnetic motor protector combination with high capacity contactor

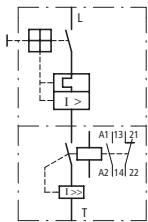
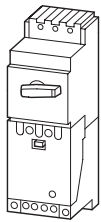

65	42	2000	2000	0,4 – 0,6	5 – 8	In this range, select motor protector in accordance with the motor nameplate full load current			
				0,6 – 1	8 – 14		1/2		1/2
				1 – 1,6	14 – 22		3/4		1
				1,6 – 2,4	20 – 35	1/2	1/2	1	1 1/2
				2,4 – 4	35 – 55	1	1	2	3
				4 – 6	50 – 80	1 1/2	1 1/2	3	5
				6 – 10	80 – 140	2	3	5	7 1/2
				10 – 16	130 – 220	3	5	10	10
				16 – 27	200 – 350	7 1/2	7 1/2	20	25
				24 – 32	275 – 425	10	10	20	30
				32 – 42	350 – 500	10	15	30	30

Manual Motor Protectors and Magnetic Motor Protector Combinations System PKZ 2

UL / CSA / IEC / CE

Type	Price
Article No.	see price list
Coil voltages shown in ()	
For other coil voltages, → page 08/053	
PKZ2/ZM-0,6 021859	
PKZ2/ZM-1 026605	
PKZ2/ZM-1,6 028978	
PKZ2/ZM-2,4 031351	
PKZ2/ZM-4 033724	
PKZ2/ZM-6 036097	
PKZ2/ZM-10 038470	
PKZ2/ZM-16 040843	
PKZ2/ZM-25 043216	
PKZ2/ZM-32 045589	
PKZ2/ZM-40 047962	
PKZ2/ZM-0,6/S(120V60HZ) 063460	
PKZ2/ZM-1/S(120V60HZ) 063470	
PKZ2/ZM-1,6/S(120V60HZ) 063480	
PKZ2/ZM-2,4/S(120V60HZ) 063490	
PKZ2/ZM-4/S(120V60HZ) 063500	
PKZ2/ZM-6/S(120V60HZ) 063510	
PKZ2/ZM-10/S(120V60HZ) 063520	
PKZ2/ZM-16/S(120V60HZ) 063530	
PKZ2/ZM-25/S(120V60HZ) 063540	
PKZ2/ZM-32/S(120V60HZ) 063550	
PKZ2/ZM-40/S(120V60HZ) 063560	

The PKZ2/ZM-... is a 3-phase thermal magnetic motor protective device incorporating adjustable bimetal trips for motor overload protection and magnetic trips to de-energize the motor circuit in case of a short-circuit.

The PKZ2/ZM-../S is a combination of the PKZ2/ZM-... manual motor protector and the S-PKZ2 high-capacity magnetic contactor.

Both devices are UL listed and CSA certified as HP rated motor controllers which provide motor running overload protection. In addition, they are UL listed and CSA certified for group applications as per NEC 430-53(c) and CEC part 1, rule 28-206. This eliminates the need for individual motor branch circuit overcurrent protective devices for each motor, thus greatly reducing the cost and space requirements of industrial control panels and assemblies. This means that a group of motors, each protected and controlled by a PKZ2/ZM-../S can be combined under a single branch circuit short-circuit and ground fault protective device, the maximum rating of which is marked on each PKZ2 motor protector.

In group installations involving a number of System PKZ 2 motor protectors, the maximum rating of the group branch circuit overcurrent protective device is based on the lowest backup overcurrent rating marked on each motor protector in the group, combined with applicable NEC/CEC installation rules.

Notes

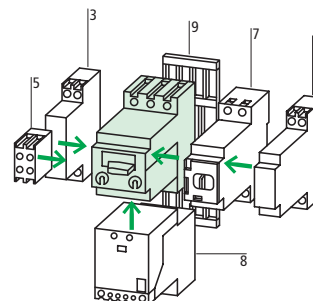

Accessories	Page
3 Standard auxiliary contact	08/036
5 Trip indicating contact	08/036
6 Shunt trip Undervoltage trip	08/038
7 Remote control operator	08/040
8 High-capacity contactor module	08/042
9 Clip plate	08/047
Other accessories	08/047

Features:

- Ratings:
42A, 600 VAC, 30HP/460V, 30HP/575V max.
- Conformity to IEC/EN 60 947 type 2 co-ordination levels
- Phase failure sensitive
- Adjustable thermal trips set to FLC. Ambient compensated.
- Adjustable magnetic trips
- Open or door mounted handle, padlockable, with 3 position indication (On - Off - Trip), see accessories
- Finger-safe construction
- 35 mm DIN rail or panel mounting

System PKZ 2 Motor Protectors

Motor Protectors without Trip Module

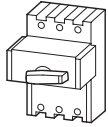
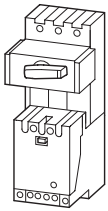
	Rated un-interrupted current	Type Article No.	Price see price list
	A	Coil voltages shown in () For other coil voltages, → page 08/056	
Basic device			
	42	PKZ2 026606	
	42	PKZ2/S (120V60HZ) 063570	
	PKZ 2 basic unit with S-PKZ 2 high capacity contact module mounted (1 N.O., 1 N.C.) Supplied on C-PKZ2 clip plate		

The PKZ 2 manual motor protector and PKZ 2/S... motor protector combination without plug-in trip modules make up one frame size rated for a maximum continuous motor load current of 42A. These devices can be stocked, or mounted and wired in a panel, without prior knowledge of motor Hp ratings. Motor overload and overcurrent protection is provided by the plug-in motor protective trip modules shown at the next page which are inserted into the slots below the handle (between the disconnect and contactor portions) and enable the motor protector to cover a motor range from fractional Hp up to 30 Hp at 460/575V AC.

Once motor loads are determined, selection of the appropriate plug-in motor protective trip module can take place. Exchanging trip modules is easy and does not require any removal of wiring or cables. Removal of the trip modules provides an additional safety benefit by creating an open circuit path to the motor. This still allows the performance of routine motor maintenance tasks and circuit function checks but effectively rules out any inadvertent energization of the motor.

Notes

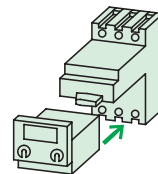

Accessories → page 08/047

Circuit for ZM... PKZ2

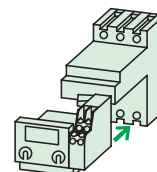
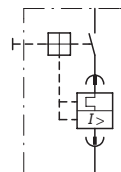

ZMR...PKZ2

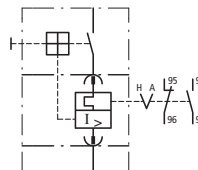

System PKZ 2 Motor Protectors Motor Protective Trip Modules

UL / CSA / IEC / CE

Manual Motor Protectors,
Motor Protector Combinations

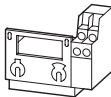
UL/CSA max. 3 phase HP rating at				Adjustable thermal range (set to motor FLC)	Setting range of adjustable magnetic trips	Type	Price	
For single phase ratings, see page 08/071								
200 V 230 V 460 V 575 V				A	A	Article No.	see price list	
HP	HP	HP	HP	A	A			
Plug-in motor protective trip modules								
with overload trip 	In this range, select motor protector in accordance with the motor nameplate FLC			0,4 – 0,6	5 – 8	ZM-0,6-PKZ2 024232	Standard trip modules ZM-...-PKZ2 are inserted on the load side of the motor protector disconnect handle. In case of overload or short circuit, the trip module will cause the motor protector switch mechanism to open and disconnect power to the load. Features: • Adjustable thermal and magnetic trips set in accordance with the motor FLC. • Tamper-proof lids that cover thermal and magnetic settings when the device is on. • Ambient compensation. • Phase failure sensitivity. • Coding accessory to insure insertion of correct module for the motor rating	
	1/2	1/2	1	0,6 – 1	8 – 14	ZM-1-PKZ2 028979		
	3/4	1	1 – 1,6	14 – 22	ZM-1,6-PKZ2 031352			
	1/2	1/2	1	1 1/2	1,6 – 2,4	20 – 35		ZM-2,4-PKZ2 033725
	1	1	2	3	2,4 – 4	35 – 55		ZM-4-PKZ2 036098
	1 1/2	1 1/2	3	5	4 – 6	50 – 80		ZM-6-PKZ2 038471
	2	3	5	7 1/2	6 – 10	80 – 140		ZM-10-PKZ2 040844
	3	5	10	10	10 – 16	130 – 220		ZM-16-PKZ2 043217
	7 1/2	7 1/2	20	25	16 – 27	200 – 350		ZM-25-PKZ2 045590
	10	10	20	30	24 – 32	275 – 425		ZM-32-PKZ2 047963
10	15	30	30	32 – 42	350 – 500	ZM-40-PKZ2 050336		
with overload relay function, with Hand/ Auto position 	In this range, select motor protector in accordance with the motor nameplate FLC			0,4 – 0,6	5 – 8	ZMR-0,6-PKZ2 033943	Trip modules with overload relay function ZMR-...-PKZ2 are inserted in the load side of the motor protector disconnect handle. Similar to the operation of an overload relay, the ZMR uses a set of auxiliary contacts to de-energize a contactor coil circuit and signal an overload condition. A short circuit will trip open the motor protector just like the standard ZM trip module. The ZMR is also supplied with a HAND/AUTO reset feature. It cannot be combined with U/A voltage trips or RE/RS remote control drives. Features: • Adjustable thermal and magnetic trips set in accordance with the motor FLC. • Tamper-proof lids that cover thermal and magnetic settings when the device is on. • Ambient compensation. • Phase failure sensitivity. • Coding accessory to insure insertion of correct module for the motor rating	
	1/2	1/2	1	0,6 – 1	8 – 14	ZMR-1-PKZ2 033950		
	3/4	1	1 – 1,6	14 – 22	ZMR-1,6-PKZ2 033952			
	1/2	1/2	1	1 1/2	1,6 – 2,4	20 – 35		ZMR-2,4-PKZ2 033955
	1	1	2	3	2,4 – 4	35 – 55		ZMR-4-PKZ2 033957
	1 1/2	1 1/2	3	5	4 – 6	50 – 80		ZMR-6-PKZ2 033966
	2	3	5	7 1/2	6 – 10	80 – 140		ZMR-10-PKZ2 033967
	3	5	10	10	10 – 16	130 – 220		ZMR-16-PKZ2 033968
	7 1/2	7 1/2	20	25	16 – 27	200 – 350		ZMR-25-PKZ2 033969
	10	10	20	30	24 – 32	275 – 425		ZMR-32-PKZ2 033973
10	15	30	30	32 – 42	350 – 500	ZMR-40-PKZ2 033975		

System PKZ 2-SP Self-protected Combination Starters, UL/CSA Type E

All-in-one starter eliminates upstream circuit breaker or fuses

As per the intent of NEC article 430 and CEC Rule 28, the self-protected control device will perform the functions of motor disconnecting means (part IX), motor branch circuit, short circuit and ground fault protection (part IV), motor controller (part VII) and motor overload protection (part III).

Up to the maximum rated short-circuit current available, no upstream circuit breaker or set of fuses is required.

The PKZ 2/ZM-.../S-SP has two sets of main contacts, both current-limiting in design. This provides it with a high interrupting rating and the capability to protect itself against damage under fault conditions. No contact welding can ensue thus providing for continuity of service.

Each unit consists of a basic frame (disconnect switch and contactor) rated to switch a motor load of 30Hp at 460V, 25 Hp at 575V AC. Eleven plug-in trip modules are available to cover motor loads ranging from fractional Hp sizes through 30 Hp at 460V and 25 Hp at 575V AC. As a result, stocking of parts is minimized and use of the starter for other motor loads may be as simple as plugging-in a new trip module and setting the trip module response dials.

Choose the PKZ2/ZM-.../S-SP starter for maximum protection and flexibility

- UL listed for use on circuits capable of delivering 65kA RMS sym. at 480Y/277V AC and 42kA RMS sym. at 600Y/347V AC.
- No backup short-circuit protection required (replaces fuses or circuit breakers required by other conventional starters).
- Plug-in trip modules can be removed/installed without disturbing power wiring.
- Field-adjustable, coordinated and sealable settings for motor overload and short-circuit trip response.
- Compact design allows installation in hard-to-fit areas.
- Exceeds IEC "Type 2" coordination without the need for additional fuses or circuit breakers.
- Removal of trip block (for maintenance or servicing) provides visible electrical isolation gap between line disconnecting and contactor portions.
- All live parts (including terminals) are shrouded against accidental contact ("finger-proof" per IEC 536), even with the plug-in trip module removed.
- Maximum continuity of service (protects itself against damage from fault currents).

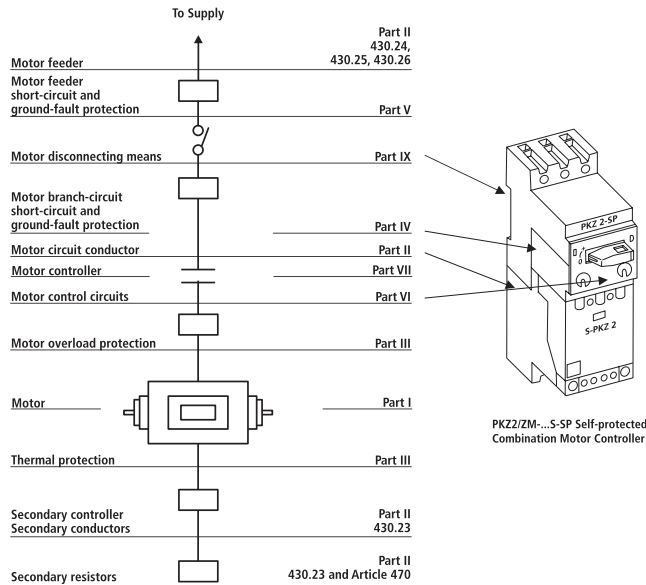
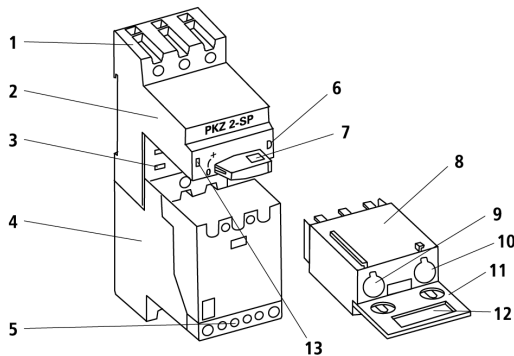

Diagram 430.1 from NEC Article 430

The PKZ2/ZM-.../S-SP self-protected starter comes standard as a one piece construction featuring a main disconnect and a contactor. The unit can be either panel or rail mounted. Integral power takeoffs are provided between the disconnect and contactor for control circuit feed. Adjustable motor protective thermal -magnetic trip modules are set in accordance with the motor full load current and plugged directly into the base of the disconnect.

Trip modules and accessories can be field installed for maximum versatility. The main disconnect and contactor modules can also be separately mounted. This is particularly suitable for full voltage reversing applications which combine the PKZ2-SP disconnect switch and two mechanically interlocked S-PKZ2 contactors. (→ page 08/024)



- 1 Both field wiring terminals on the line side (disconnect) and load side (contactor) have large service entrance spacings typical of molded case circuit breakers.
- 2 The main disconnect isolating contacts are current limiting in design.
- 3 Visible "finger-touch-proof" open circuit power path when trip module is removed.
- 4 The contactor main switching contacts are also current limiting in design and significantly enhance the device's overall interrupting ability.
- 5 The contactor comes standard with 1 N.O. and 1 N.C. auxiliary contacts. 2 N.O. contacts are also available.
- 6 The trip module can be set and then sealed with a wire lock.
- 7 Padlockable handle with ON, OFF and + (tripped) indication.
- 8 Field-interchangeable plug-in motor protective trip modules with coordinated overload and short-circuit protection built in.
- 9 Adjustable magnetic trip dial, range 8.5 - 14 x trip module rating.
- 10 Adjustable thermal trip dial, range 0.6 - 1 x trip module rating (set to motor FLC.)
- 11 Test-to-trip slot.
- 12 Coding feature to differentiate trip modules.
- 13 Short-circuit trip indicator K-AGM-PKZ2 provides visual indication of short circuit trip condition and differentiation between short-circuit and general trip due to overload and/or voltage trips.

System PKZ 2-SP

Self-protected Combination Starters - FVNR, FVR, Open Type, UL/CSA Type E

Max. HP rating, 3 phase 200 V 230 V 460 V 575 V	Type Specify coil voltage and frequency, → page 03/034	Price see price list	Notes:
HP HP HP HP			
Full voltage, non-reversing starter			
without trip module			
10 15 30 25	PKZ2/S-SP (...)		Ready to be mounted and wired in its own enclosure. The HP values shown are the maximum allowable and are dependent on the trip module chosen. Trip modules shown below can be selected later according to desired motor HP and FLC and plugged into the disconnect to complete the starter. Trip modules can be field installed for maximum flexibility.
Full voltage, reversing starter			
without trip module			
10 15 30 25	PKZ2/S-SP-FVR (...)		Supplied with factory mounted and wired disconnect and mechanically interlocked contactors. The HP values shown are the maximum allowable and are dependent on the trip module chosen. Trip modules shown below can be selected later according to desired motor HP and FLC and plugged into the disconnect to complete the starter. Trip modules can be field installed for maximum flexibility.

Trip modules						with overload function			
Max. HP rating 3 phase				Adjustable thermal current range	Adjustable magnetic current range	Type	Price	Type	Price
200V	230V	460V	575V			Article No.	see price list	Article No.	see price list
HP	HP	HP	HP	A ¹⁾	A				
Trip modules are added to above devices to complete starter									
In this range select devices in accordance with motor FLC				0.4 - 0.6	5 - 8	ZM-0.6-PKZ2 024232		ZMR-0.6-PKZ2 033943	
		1/2	1/2	0.6 - 1.0	8 - 14	ZM-1-PKZ2 028979		ZMR-1-PKZ2 033950	
	1/3	3/4	1	1.0 - 1.6	14 - 22	ZM-1.6-PKZ2 031352		ZMR-1.6-PKZ2 033952	
1/2	1/2	1	1 1/2	1.6 - 2.4	20 - 35	ZM-2.4-PKZ2 033725		ZMR-2.4-PKZ2 033955	
1	1	2	3	2.4 - 4.0	35 - 55	ZM-4-PKZ2 036098		ZMR-4-PKZ2 033957	
1 1/2	1 1/2	3	5	4.0 - 6.0	50 - 80	ZM-6-PKZ2 038471		ZMR-6-PKZ2 033966	
2	3	5	7 1/2	6 - 10	80 - 140	ZM-10-PKZ2 040844		ZMR-10-PKZ2 033967	
3	5	10	10	10 - 16	130 - 220	ZM-16-PKZ2 043217		ZMR-16-PKZ2 033968	
5	7 1/2	20	25	16 - 27	200 - 350	ZM-25-PKZ2 045590		ZMR-25-PKZ2 033969	
10	10	20	-	24 - 32	275 - 425	ZM-32-PKZ2 047963		ZMR-32-PKZ2 033973	
10	15	30	-	32 - 42	350 - 500	ZM-40-PKZ2 050336		ZMR-40-PKZ2 033975	

- Notes:**
- ¹⁾ Set bimetal trips (yellow dial) to motor FLC
 - Tripping current = 125% of setting
 - For motors of service factor 1.0, set dial to 0.9 of motor FLC setting
 - Ambient compensated
 - Phase failure sensitive

Trip module type ZMR

Under overload and short-circuit fault conditions the standard trip module will open the main disconnect portion of the PKZ2 Self-protected Starter, much like the operation of an inverse time molded case breaker. As an option, the trip module type ZMR can be provided. It features a set of auxiliary contacts which are activated under overload conditions. Similar to the operation of an overload relay in a conventional combination controller, the N.C. contact can be used to de-energize the contactor coil circuit in the event of an overload and N.O. contact can be used to annunciate the condition. A short-circuit fault will trip open the main disconnect instantaneously, just like the standard trip module.

The ZMR module is ideal for applications which need to take full advantage of the self-protected starter's capabilities over conventional combination controllers, but wish to retain the operating features of a conventional overload relay in a starter.

UL listed / CSA certified Maximum interrupting ratings

240 V AC	100 kA RMS sym.
480 Y / 277 V AC	65 kA RMS sym.
600 Y / 347 V AC	42 kA RMS sym.
up to 27 A	Suitable for maximum 600 V AC power distribution system when the voltage between any phase to ground does not exceed 347 V
up to 42 A	Suitable for maximum 480 V AC power distribution system when the voltage between any phase to ground does not exceed 277 V

System PKZ2-SP Combination Starters - Self-protected FVNR, UL/CSA Type E

Rating data UL/CSA maximum Horsepower rating (HP) 50/60Hz 3 phase				Adjustable current range		with ZM trip module		Price see price list		
200 V HP	230 V HP	460 V HP	575 V HP	Thermal setting (set to motor FLC) ¹⁾	Magnetic trip	Type	Enclosed	Open		
				A	A	Specify coil voltage and frequency, → see below	General purpose Type 1 Replace <input type="checkbox"/> with suffix /S	Industrial use Type 12 dusttight Replace <input type="checkbox"/> with suffix /SD Type 3R weather-proof Replace <input type="checkbox"/> with suffix /DW	Insulating material Type 12 corrosion-resistant dusttight Replace <input type="checkbox"/> with suffix /I	without enclosure Delete <input type="checkbox"/> in type
In this range, select devices in accordance with motor FLC				0.4 - 0.6	5 - 8	PKZ2/ZM-0.6/S-SP <input type="checkbox"/> (...)				
	1/2	1/2		0.6 - 1.0	8 - 14	PKZ2/ZM-1/S-SP <input type="checkbox"/> (...)				
	1/3	3/4	1	1.0 - 1.6	14 - 22	PKZ2/ZM-1.6/S-SP <input type="checkbox"/> (...)				
1/2	1/2	1	1 1/2	1.6 - 2.4	20 - 35	PKZ2/ZM-2.4/S-SP <input type="checkbox"/> (...)				
1	1	2	3	2.4 - 4.0	35 - 55	PKZ2/ZM-4/S-SP <input type="checkbox"/> (...)				
1 1/2	1 1/2	3	5	4.0 - 6.0	50 - 80	PKZ2/ZM-6/S-SP <input type="checkbox"/> (...)				
2	3	5	7 1/2	6 - 10	80 - 140	PKZ2/ZM-10/S-SP <input type="checkbox"/> (...)				
3	5	10	10	10 - 16	130 - 220	PKZ2/ZM-16/S-SP <input type="checkbox"/> (...)				
7 1/2	7 1/2	20	25	16 - 27	200 - 350	PKZ2/ZM-25/S-SP <input type="checkbox"/> (...)				
10	10	20	-	24 - 32	275 - 425	PKZ2/ZM-32/S-SP <input type="checkbox"/> (...)				
10	15	30	-	32 - 42	350 - 500	PKZ2/ZM-40/S-SP <input type="checkbox"/> (...)				

Notes: ¹⁾ Set bimetal trips (yellow dial) to motor FLC
 – Tripping current = 125% of setting
 – For motors of service factor 1.0, set dial to 0.9 of motor FLC setting
 – Ambient compensated
 – Phase failure sensitive

To order specify:

- Type number
- Enclosure suffix
- Coil voltage
- Accessories

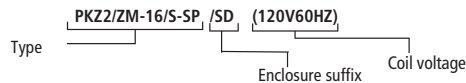

24V DC: Add suffix "-G" in part number.
 Example: PKZ2/ZM-16/S-G-SP (24VDC)

Available Coil Voltages

Standard voltages				Special voltages (other than the standard coils listed) ¹⁾		DC
AC						
24V 50Hz	24V 60Hz	110V 50Hz, 120V 60Hz	380V 50Hz, 440V 60Hz	24V 50/60Hz	...V 50Hz (24 - 600V)	24V
48V 50Hz	208V 60Hz	190V 50Hz, 220V 60Hz	400V 50Hz, 440V 60Hz	110V 50/60Hz	...V 60Hz (24 - 600V)	
240V 50Hz		220V 50Hz, 240V 60Hz, 230V 50Hz, 240V 60Hz	415V 50Hz, 480V 60Hz	230V 50/60Hz		

¹⁾ when ordering special coils, please state the required actuating voltage from the given range (...-...V).

System PKZ2-SP Combination Starters - Self-protected FVNR, UL/CSA Type E

with ZMR trip module			
Type	Price see price list		
Specify coil voltage and frequency, → see below	Enclosed		Open
		General purpose Type 1 Replace <input type="checkbox"/> with suffix /S	Industrial use Type 12 dusttight Replace <input type="checkbox"/> with suffix /SD Type 3R weather-proof Replace <input type="checkbox"/> with suffix /DW
PKZ2/ZMR-0.6/S-SP <input type="checkbox"/> (...)			
PKZ2/ZMR-1/S-SP <input type="checkbox"/> (...)			
PKZ2/ZMR-1.6/S-SP <input type="checkbox"/> (...)			
PKZ2/ZMR-2.4/S-SP <input type="checkbox"/> (...)			
PKZ2/ZMR-4/S-SP <input type="checkbox"/> (...)			
PKZ2/ZMR-6/S-SP <input type="checkbox"/> (...)			
PKZ2/ZMR-10/S-SP <input type="checkbox"/> (...)			
PKZ2/ZMR-16/S-SP <input type="checkbox"/> (...)			
PKZ2/ZMR-25/S-SP <input type="checkbox"/> (...)			
PKZ2/ZMR-32/S-SP <input type="checkbox"/> (...)			
PKZ2/ZMR-40/S-SP <input type="checkbox"/> (...)			

Notes:

Standard features:

- UL listed, CSA certified, self-protected combination motor controller. UL 508 / CSA 22.2, No. 14 Type E.
- Factory mounted and labeled contactor and disconnect portion rated max. 42A, 30 HP at 460V; max. 27A, 25 Hp at 575V.
- No backup overcurrent protection required up to its full interrupting rating.
- Continuity of service (protects itself against damage under fault conditions).
- Plug-in trip module, which creates an open circuit path to the motor when removed. For additional safety!
- Adjustable thermal and magnetic trips; built-in phase loss differential trip.
- Built-in 1N.O. and 1 N.C. auxiliary contacts in the contactor portion. 2 N.O. are also available.
- Electrical life: 1 million operations, AC-3 (30/25 HP at 460/575V)
- Adapter plate for rail or panel mounting.
- Control circuit transformer tap-off terminals on load side of disconnect.
- Allows mounting of accessories such as voltage trips, standard and trip indicating auxiliary contacts.
- Enclosed starters provided with door interlocking handle.
- In the event of an overload condition, the N.C. contact in the ZMR...-PKZ2 trip module opens the contactor coil circuit and the N.O. contact may be used to remotely signal an overload condition. On a short circuit, the main disconnect switch opens.

Additional information	Page
Accessories	08/047
Factory modifications	03/046
Other operating voltages	08/034
Technical data	08/066
Dimensions	08/076
Weights	14/020

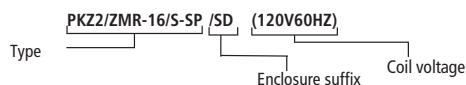

24V DC: Add suffix "-G" in part number.
Example: PKZ2/ZM-16/S-G-SP (24VDC)

System PKZ 2 Motor Protectors





Auxiliary Contacts, Trip-indicating Contacts, Trip Indicator, Current Limiter

Manual Motor Protectors,
Motor Protector Combinations

Number of Auxiliary Contacts N.O. = normally open N.C. = normally closed N.O. N.C.	Connection Diagram	Circuit Diagram	Type
Standard auxiliary contacts for motor protectors and motor protector combinations			
1 1			+NHI11-PKZ2 093050
2 2			+NHI22-PKZ2 095423
for motor protector combinations			
1 1			+NHI11S-PKZ2 005250
2 2			+NHI22S-PKZ2 002877
2 x 1 2 x 1			+NHI2-11S-PKZ2 012369
Trip-indicating auxiliary contacts			
with short-circuit indicator			
2 x (1 N.O. 1 N.C.)			+AGM2-11-PKZ2 019488
<p>"+" this set of contacts actuates under all trip conditions ">" this set of contacts actuates only under short-circuit trip conditions</p>			
Short-circuit indicator			
<p>Trip "+"</p> <p>On/Off</p>			+K-AGM-PKZ2 024234
Current limiter			
Fuseless, current limiting set of contacts housed in a module. Increases short-circuit current rating of PKZ 2/ZM up to 100kA/500V AC in IEC group applications. Not UL/CSA.	<p>Rated uninterrupted current $I_u = 40 A$</p>		+CL-PKZ2 078812

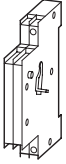
System PKZ 2 Motor Protectors

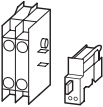
Auxiliary Contacts, Trip-indicating Contacts, Trip Indicator, Current Limiter

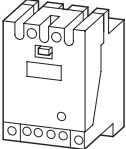
	Type	Price
	Article No. when ordered separately	see price list
	<p>NHI11-PKZ2 090677</p> <p>NHI22-PKZ2 097796</p>	<p>The side mounted auxiliary contacts NHI-...-PKZ2 operate in conjunction with the motor protector contacts.</p> <p>Can be mounted to a motor protector or motor protector combination.</p> <p>Can be combined with AGM trip indicating contacts.</p>
	<p>NHI11S-PKZ2 007623</p> <p>NHI22S-PKZ2 000504</p> <p>NHI2-11S-PKZ2 009996</p>	<p>Type NHI2-11S-PKZ2 has a set of contacts operated by the motor protector, the other set by the contactor.</p> <p>Can be mounted to motor protector combination.</p> <p>Can be combined with AGM trip-indicating contacts.</p>
	AGM2-11-PKZ2 017115	<p>AGM....-PKZ2 provides trip differentiating contacts and is supplied with K-AGM-PKZ2 red short-circuit indicator</p> <p>Can be mounted to motor protector or motor protector combination.</p> <p>Can be combined with NHI... or NHI...S</p>
	K-AGM-PKZ2 021861	<p>Provides a visual signal of a short-circuit trip condition via a resettable red flag indicator.</p> <p>Differentiated trip signalling possible in conjunction with handle position.</p>
	CL-PKZ2 076439	<p>Max. rated operational voltage $U_e = 690\text{ V}$</p> <p>Can be mounted to motor protector or mounted separately on EZ base.</p>

Notes

Standard auxiliary contacts

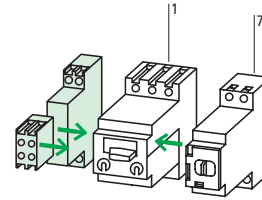

Accessories	page
1 Motor protector	08/028
7 Remote drives	08/040
Other accessories	08/047

Trip-indicating auxiliary contact and short-circuit indicator

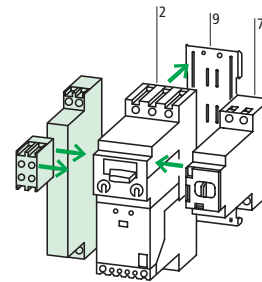

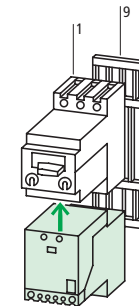

Accessories	page
2 Motor protector	08/028
7 Remote drive	08/040
9 Clip plate	08/047
Other accessories	08/047

Current limiter

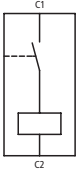
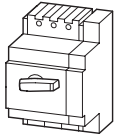

Accessories	page
1 Motor protector	08/028
9 Clip plate	08/047
Other accessories	08/047

System PKZ 2 Motor Protectors Shunt Trips, Undervoltage Trips

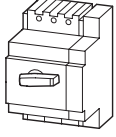
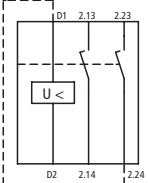
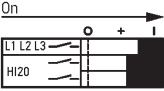
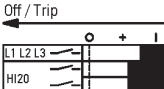
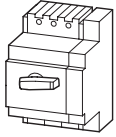
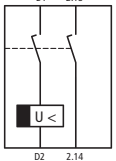
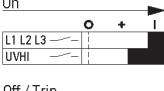
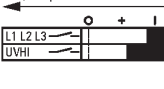
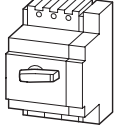
Circuit diagram	Connection diagram	Operating voltage	Type																																	
		Voltage and frequency combinations possible with one coil in the voltage trip	Article No. When ordered with basic device Coil voltages shown in () For other coil voltages, → page 08/055																																	
Shunt trips																																				
For AC and DC 		<table border="1"> <tr> <td>24 V DC</td> <td>48 V DC</td> <td>60 V DC</td> </tr> <tr> <td>24 V 50 Hz</td> <td>48 V 50 Hz</td> <td></td> </tr> <tr> <td>24 V 60 Hz</td> <td>48 V 60 Hz</td> <td></td> </tr> <tr> <td>110 V DC</td> <td>125 V DC</td> <td>250 V DC</td> </tr> <tr> <td>110 V 50 Hz</td> <td>127 V 50 Hz</td> <td>220 V 50 Hz</td> </tr> <tr> <td>230 V 50 Hz</td> <td>240 V 50 Hz</td> <td></td> </tr> <tr> <td>110 V 60 Hz</td> <td>120 V 60 Hz</td> <td>208 V 60 Hz</td> </tr> <tr> <td>220 V 60 Hz</td> <td>240 V 60 Hz</td> <td></td> </tr> <tr> <td>380 V 50 Hz</td> <td>400 V 50 Hz</td> <td>415 V 50 Hz</td> </tr> <tr> <td>440 V 50 Hz</td> <td>500 V 50 Hz</td> <td></td> </tr> <tr> <td>480 V 60 Hz</td> <td>600 V 60 Hz</td> <td></td> </tr> </table> 	24 V DC	48 V DC	60 V DC	24 V 50 Hz	48 V 50 Hz		24 V 60 Hz	48 V 60 Hz		110 V DC	125 V DC	250 V DC	110 V 50 Hz	127 V 50 Hz	220 V 50 Hz	230 V 50 Hz	240 V 50 Hz		110 V 60 Hz	120 V 60 Hz	208 V 60 Hz	220 V 60 Hz	240 V 60 Hz		380 V 50 Hz	400 V 50 Hz	415 V 50 Hz	440 V 50 Hz	500 V 50 Hz		480 V 60 Hz	600 V 60 Hz		+A-PKZ2-A 063966 +A-PKZ2-B 063965 +A-PKZ2-C 063962
24 V DC	48 V DC	60 V DC																																		
24 V 50 Hz	48 V 50 Hz																																			
24 V 60 Hz	48 V 60 Hz																																			
110 V DC	125 V DC	250 V DC																																		
110 V 50 Hz	127 V 50 Hz	220 V 50 Hz																																		
230 V 50 Hz	240 V 50 Hz																																			
110 V 60 Hz	120 V 60 Hz	208 V 60 Hz																																		
220 V 60 Hz	240 V 60 Hz																																			
380 V 50 Hz	400 V 50 Hz	415 V 50 Hz																																		
440 V 50 Hz	500 V 50 Hz																																			
480 V 60 Hz	600 V 60 Hz																																			
Undervoltage trips, undelayed																																				
	for AC for DC		 +U-PKZ2(120V60HZ) 063612 +U-PKZ2(24V DC) 002558																																	
For AC, with auxiliary contact 	 		 +U-HI20-PKZ2(120V60HZ) 063626																																	
Drop-off Delayed (200 ms)																																				
For AC, with auxiliary contact 	 		 +UVHI-PKZ2(120V60HZ) 063637																																	

System PKZ 2 Motor Protectors Shunt Trips, Undervoltage Trips

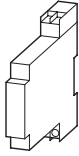
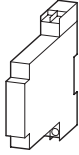
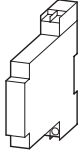
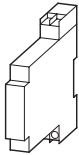
	Type	Price	
	Article. No. when ordered separately	see price list	
	Coil voltages shown in () For other coil voltages, → page 08/055		
	A-PKZ2-A 063967		Shunt trips are available in three models which cover a wide range of AC and DC voltages. They can be used in combination with R(E)(S)-PKZ2 remote control drives.
	A-PKZ2-B 063964		
	A-PKZ2-C 063930		
	U-PKZ2(120V60HZ) 065686		Can be combined with the motor protector to accomplish Emergency-Stop circuitry per IEC/EN 60 204. Can be used in combination with R(E)(S)-PKZ2 remote control drives.
	U-PKZ2(24V DC) 014463		
	U-HI20-PKZ2(120V60HZ) 063655		Can be combined with the motor protector to accomplish Emergency-Stop circuitry per IEC/EN 60 204. Can be used in combination with R(E)(S)-PKZ2 remote control drives. Includes a set of early-make contacts. In the trip position, both contacts will be closed. The trip coil can be energized early by jumpering from the contact (see diagram), however in this mode it will not be possible to combine it with the R(E)(S)-PKZ2 remote control drives.
	UVHI-PKZ2(120V60HZ) 063664		Has a built-in time delay to prevent tripping due to momentary power losses of 200 ms or less. In the trip position, both contacts will be closed. Can be used in combination with R(E)(S)-PKZ2 remote control drives.

Notes

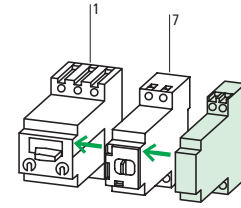

Accessories	page
1 Motor protector	08/028
7 Remote control drive	08/040
Other accessories	08/047

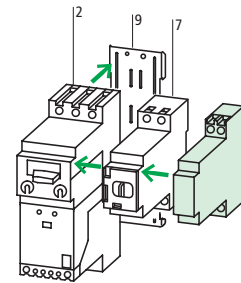

Accessories	page
2 Motor protector	08/028
7 Remote control drive	08/040
9 Clip plate	08/047
Other accessories	08/047
Other actuating voltages	08/055

System PKZ 2 Motor Protectors Remote Control Drives

Circuit diagram for pulsed operation

Remote control drive RE-PKZ2

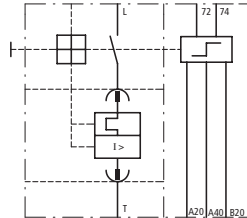
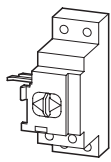

OFF and RESET separate

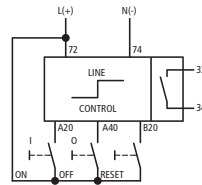

OFF equals RESET

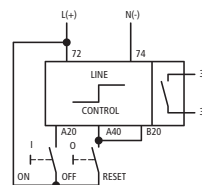

Line and control feeds have the same potential.

The control section can be energized by a single impulse (≤ 2 VA/W power draw) of 15 ms duration, or by a main tained contact. Upon energizing, the line connection draws its power requirement (700 VA/W for a duration of 30 ms) directly from the line.

Control section can also be actuated via auxiliary contacts from various Moeller Electric components: NHI, AGM, ETR4-VS3, EK... and dry output contacts from PLCs with no RC filter type surge suppression.

Remote control drive RS-PKZ2

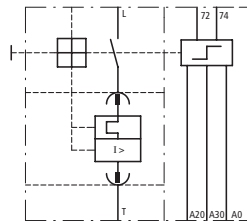
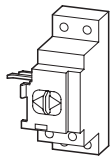

OFF equals RESET

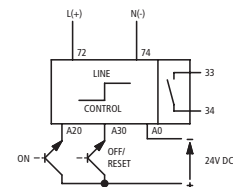
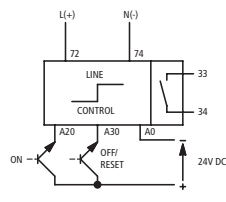

Line and control sections are galvanically separated. The control section is energized solely from a 24V DC source by a single impulse (≤ 2 VA/W, 15 ms duration) or by a maintained contact. Suitable for energizing directly from an electronic PLC output.

Upon energizing, the line connection draws its power requirement (700 VA/W for a duration of 30 ms) directly from the line.

Notes

Minimum command time for RE-PKZ2, RS-PKZ2 remote control drives

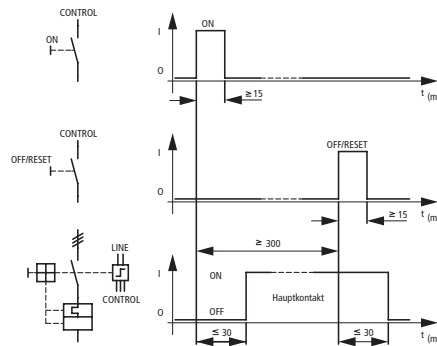

System PKZ 2 Motor Protectors Remote Control Drives

Type	Price
Article No. Control voltage is shown in () For other voltages, → page 08/056	see price list
RE-PKZ2(110–120V50/60HZ,DC) 063673	<p>Remote control drives can be used with both the motor protector and motor protector combination. They are used to electrically operate the motor protector (ON / OFF and Reset to OFF (after trip) operations.) They can be switched off at the device and the thumb-grip handle can be padlocked using a 6 mm padlock. Suitable for use with either AC or DC voltages.</p> <p>Can be combined with undervoltage trips and shunt trips. Always use standard auxiliary contact Type NHI... when using remote control drives to electrically signal the open or closed status of the motor protector.</p> <p>Remote control drives cannot be used in conjunction with (R)H-PKZ2 door interlock handle.</p> <p>Mounting is possible in both ON and OFF positions of the motor protector. An internal electronic interlock always sets OFF as the default setting.</p> <p>The thumb-grip handle has 2 positions: HAND and AUTO</p> <p>In HAND</p> <ul style="list-style-type: none"> the drive displays the color GREEN and blocks any remote electrical actuation. the internal signalling contact 33/34 is open. <p>In AUTO</p> <ul style="list-style-type: none"> the drive displays the color RED, indicating that remote electrical actuation is possible. The internal signalling contact 33/34 is closed.
RE-PKZ2(24V50/60HZ,DC) 063670	
RS-PKZ2(110–120V50/60HZ,DC) 063685	
RS-PKZ2(24V50/60HZ,DC) 063682	

RE-PKZ2 and RS-PKZ2 remote control drives can be used to electrically operate the motor protector from a remote location:

- OFF to ON
- ON to OFF
- Reset to OFF after trip

Highly desirable in factory automated operations and/or physically hard to reach locations!

Notes

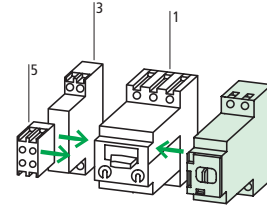

Accessories	page
1 Motor protector	08/028
3 Standard auxiliary contact	08/036
5 Trip-indicating auxiliary contact	08/036
Other accessories	08/047

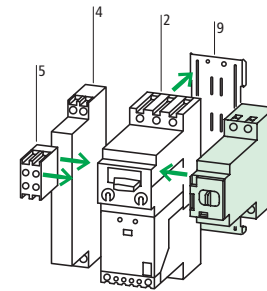

Accessories	page
2 Motor protector	08/028
4 Standard auxiliary contact	08/036
5 Trip-indicating auxiliary contact	08/036
9 Clip plate	08/047
Other actuating or supply voltages	08/056

Note:
The supply voltage refers to the line and control feed for the RE-PKZ 2 and the line feed for the RS-PKZ 2. The control section of the RS-PKZ 2 is supplied with 24 V DC only. Both remote control drives will draw their power requirement (700 VA for 30 ms) directly from the line.

System PKZ 2 Motor Protectors Magnetic Contactors, Surge Suppressors

Circuit diagram	UL/CSA Maximum 3 phase HP rating at				Number of contacts		For use with
	200 V HP	230 V HP	460 V HP	575 V HP	N.O. = normally closed N.C. = normally closed	N.O. N.C.	

High capacity magnetic contactor module

With internal current limitation feature to increase short-circuit current rating and self-protection characteristics of PKZ 2/ZM-.../S motor protector combination

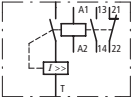
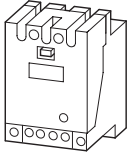
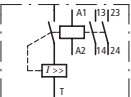
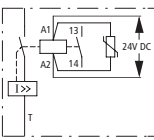
AC operated		10	15	30	30	1	1	PKZ2 PKZ2/ZM-...
		10	15	30	30	2	-	PKZ2 PKZ2/ZM-...
DC operated		10	15	30	30	1	-	PKZ2 PKZ2/ZM-...

Surge suppressor Varistor type for AC coils

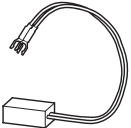
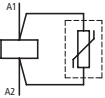
		24 – 48 V	S-...-PKZ2
		110 – 250 V	
		380 – 415 V	

Mounting base

For separate mounting of the S-...-PKZ2 contactor		S-...-PKZ2 CL-PKZ2
---	---	-----------------------

System PKZ 2 Motor Protectors

Magnetic Contactors, Surge Suppressors

Type	Price
Article No. Coil voltages shown in () For other voltages, → page 08/051	see price list
S-PKZ2(120V60HZ) 063694	The contactors can be directly plugged into the manual motor protector PKZ2/ZM-... to form a magnetic motor protector combination. Use of a C-PKZ2 clip plate is essential for this purpose (see diagram at right). The combination on a clip plate can then either be conventionally panel mounted using screws, or clipped onto one or two 15mm high DIN rail(s) conforming to EN 50 022-35. The contactors can also be individually mounted using EZ-PKZ2 mounting base. RC filter surge suppressors for AC coils, as an alternative to varistor types shown on this page, are available upon request.
S/HI20-S-PKZ2(120V60HZ) 063701	The contactors can also be individually mounted using EZ-PKZ2 mounting base. RC filter surge suppressors for AC coils, as an alternative to varistor types shown on this page, are available upon request.
S-G-PKZ2(24VDC) 070921	Contactors that are individually mounted can also be mechanically interlocked using the MV-PKZ2 mechanical interlock, e.g. for reversing applications. The DC operated contactor comes standard with 1 N.O. contact and built-in surge suppression. Coil exchange and different auxiliary contact configurations are not possible.
VGSPKZ48 063974	Surge suppressors for AC coils of S-...-PKZ2 contactors. RC filters also available upon request.
VGSPKZ250 063973	
VGSPKZ415 063972	
EZ-PKZ2 028596	Used to mount the S-...-PKZ2 contactor separate from the PKZ2... motor protector. Always required for reversing applications. Also, allows extra contactor operated auxiliary contacts to be added: HI11-S/EZ-PKZ2 (1 N.O. and 1 N.C.). The base can either be panel mounted using screws (M4) or clipped onto a 35mm DIN rail conforming to EN 50 022.



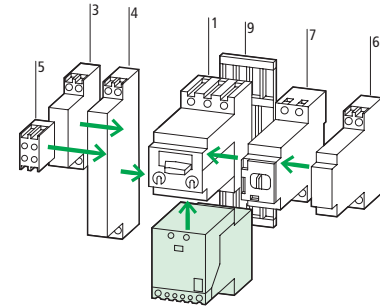



Notes

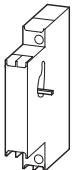

Accessories

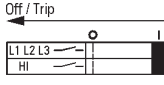
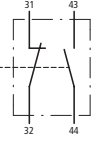
	page
1 Motor protector	08/028
3 Standard auxiliary contact	08/036
4 Standard auxiliary contact	08/036
5 Trip-indicating auxiliary contact	08/036
6 Shunt trip Undervoltage trip	08/038
7 Remote control drive	08/040
9 Clip plate	08/047
Other accessories	08/047
Other actuating voltages	08/057

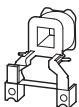
System PKZ 2 Motor Protectors Accessories for High Capacity Magnetic Contactors

<p>Auxiliary contacts N.O. = normally open N.C. = normally closed</p>	<p>Connection diagram</p>	<p>Type Article No.</p>	<p>Price see price list</p>
<p>Control circuit terminal tap-offs Complies with IEC and UL/CSA</p> 		<p>ST-PKZ2 010998</p>	
<p>Auxiliary contact module Fits to the side of separately mounted contactors</p>  <p>1 N.O. 1 N.C.</p>   		<p>HI11-S/EZ-PKZ-2 090305</p>	
<p>Auxiliary contact inserts Mounts in the top portion of the contactor</p>  <p>1 N.O. 1 N.C.</p> <p>2 N.O.</p>		<p>HI11-S-PKZ2 033936</p> <p>HI20-S-PKZ2 033935</p>	
<p>Separate coil</p> 		<p>J-S-PKZ2(120V60HZ) 063723</p>	
<p>Mechanical interlock</p> 		<p>MV-PKZ2 033938</p>	

System PKZ 2 Motor Protectors

Accessories for High Capacity Magnetic Contactors

Provides easy access to the load side terminals of the PKZ2/ZM motor protector for control circuit tap-off purposes when the protector and S-PKZ2 high capacity magnetic contactor are mounted together as a combination unit (PKZ2/ZM-.../S). Accepts 2.8 mm fast-on connectors (insulated/non-insulated); control circuit conductor cross section range: AWG 16...20, Cu only. Max. current draw: 1A or 15% of thermal dial (FLC) value, whichever is less. Increase the setting of the dial accordingly to compensate for the tapped off current.

Provides an additional set of contactor operated auxiliary contacts (1 N.O. & 1 N.C.) for S-PKZ2 contactors that are mounted separately using the EZ-PKZ2 mounting base.

Auxiliary contact inserts are used as an exchange or replacement of the insert normally supplied with the contactor. Exception: exchange or replacement of insert is not possible with DC operated contactor type S-G-PKZ2.

Separate coils available in AC voltages (→ page 08/051). See page 08/036 for varistor type surge suppressors. RC type filters can also be supplied upon demand.

To mechanically interlock two S-PKZ2 contactors. Contactors must be separately mounted using EZ-PKZ2 mounting bases. Useful for reversing applications or when there is a need to mechanically interlock the contactors of two PKZ2/ZM-.../S motor protector combinations (e.g. 2-speed motors with 2 separate windings). Supplied with 4 end brackets.

Notes

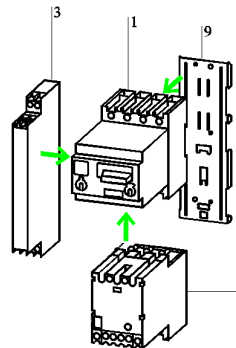

Accessories	page
1 Motor protector	08/028
3 Standard auxiliary contact	08/036
8 High capacity magnetic contactor	08/042
9 Clip plate	08/047

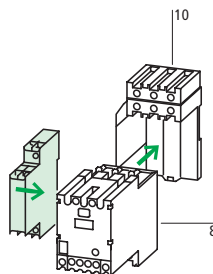

Accessories	page
8 High capacity magnetic contactor	08/042
10 Base for separate mounting	08/042
Other operating voltages	08/057