

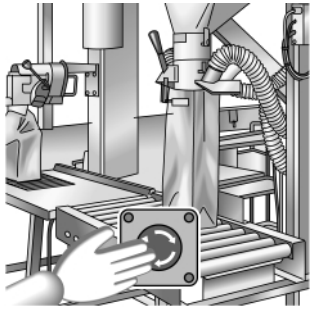

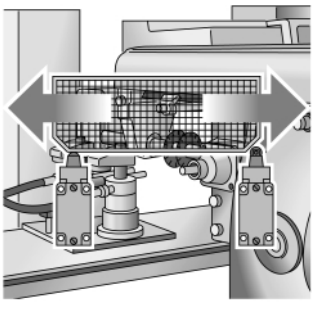

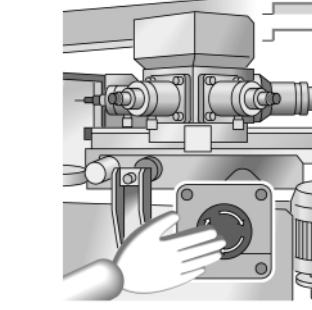

PREVENTA™ XPS Safety Relays Selection Guide



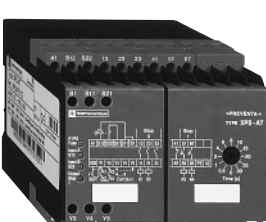
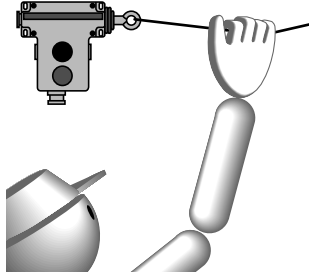
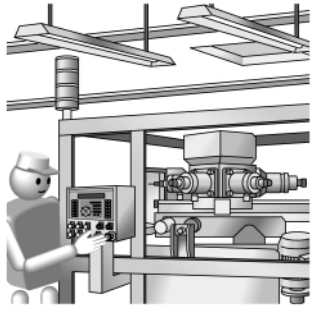
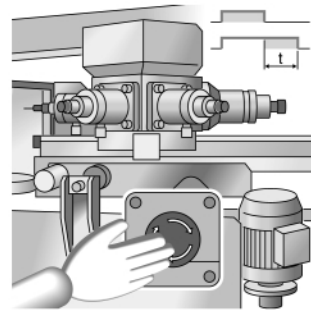

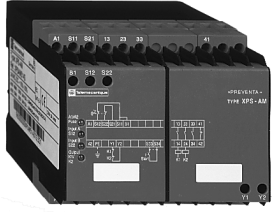
Applications				
Product Modules		For emergency stop monitoring and limit switch monitoring		
				
Conformity to Standards	Machine Assemblies	IEC 204-1, EN 292, EN 418, EN 60204-1		
	Product	EN 954-1–Category 3 EN 1088	EN 954-1–Category 3 EN 1088	EN 954-1–Category 4 (instantaneous contacts) EN 954-1–Category 3 (time delayed contacts) EN 1088
Number of Circuits	Safety	2 N.O.	3 N.O.	3 N.O. instantaneous contacts + 2 N.O. time delayed contacts
	Signaling	—	1 N.C.	1 N.C.
Indication		2 LEDs	2 LEDs	4 LEDs
Supply Voltage		24 Vac/dc 115 Vac 230 Vac	24 Vac/dc	24 Vac/dc 115 Vac 230 Vac
Synchronization time between inputs		—	—	75 ms (when wired for automatic starting)
Input channel voltage	24 V / 48 V version	24 Vac/dc/–	24 Vac/dc/–	24 Vdc/–
	115 V / 230 V version	115/230 Vac	– / –	48 Vac/dc
Catalog number shown with module supply voltage		XPSAL5110 24 Vac/dc XPSAL3410 115 Vac XPSAL3710 230 Vac	XPSAX5120 24 Vac/dc – –	XPSAT5110 24 Vac/dc XPSAT3410 115 Vac XPSAT3710 230 Vac
Product type		XPSAL	XPSAX	XPSAT
Page number		80	80	80

PREVENTA™ XPS Safety Relays

Selection Guide

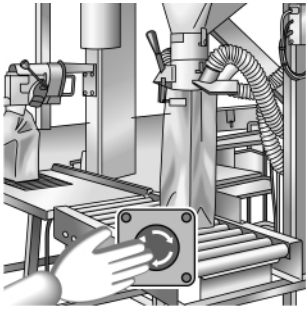
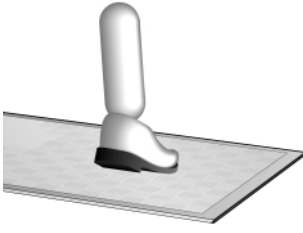
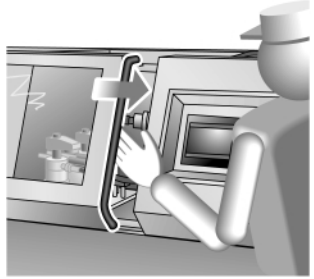
Applications				
Product Modules		For emergency stop monitoring and limit switch monitoring		
				
Conformity to Standards	Machine Assemblies	IEC 204-1, EN 292, EN 418 EN 60204-1		
	Product	EN 954-1 – Category 4 EN 1088		
Number of Circuits	Safety	2 N.O.	3 N.O.	6 N.O.
	Signaling	—	1 N.C.	1 N.C.
Indication		4 LEDs		
Supply Voltage		24 Vac/dc 48 Vac/dc 115 Vac 230 Vac		
Synchronization Time Between Inputs		300 ms (when wired for automatic starting)		
Input channel voltage	24 V / 48 V Version	24 Vdc/48 Vdc		
	115 V / 230 V Version	48 Vdc/48 Vdc		
Catalog Number Shown With Module Supply Voltage		XPSAS5140 24 Vac/dc XPSAS5340 48 Vac/dc XPSAS3440 115 Vac XPSAS3740 230 Vac	XPSAM5140 24 VAac/dc XPSAM5340 48 Vac/dc XPSAM3440 115 Vac XPSAM3740 230 Vac	XPSAP5140 24 Vac/dc XPSAP5340 48 Vac/dc XPSAP3440 115 Vac XPSAP3740 230 Vac
Product Type		XPSAS	XPSAM	XPSAP
Page Number		85	85	85

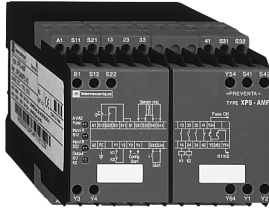
PREVENTA™ XPS Safety Relays Selection Guide



Applications				
Product Modules		For emergency stop monitoring, limit switch monitoring, pressure sensitive mat, and safety edge monitoring		
				
Conformity to Standards	Machine Assemblies	IEC 204-1, EN 292, EN 418, EN 60204-1,		
	Product	EN 954-1 – Category 4 EN 1088		
Number of Circuits	Safety	2 N.O.	3 N.O.	6 N.O.
	Signaling	2 solid-state for messages to PLC	1 N.C. + 2 solid-state for messages to PLC	1 N.C. + 2 solid-state for messages to PLC
Indication		4 LEDs		
Supply Voltage		24 Vac/dc 48 Vac/dc 115 Vac 230 Vac		
Synchronization Time Between Inputs		300 ms (when wired for automatic starting)		
Input Channel Voltage	24 V / 48 V Version	24/48 Vdc		
	115 V / 230 V Version	48 Vdc / 48 Vac		
Catalog Number Shown With Module Supply Voltage		XPSASF5142 24 Vac/dc XPSASF5342 48 Vac/dc XPSASF3442 115 Vac XPSASF3742 230 Vac	XPSAMF5142 24 Vac/dc XPSAMF5342 48 Vac/dc XPSAMF3442 115 Vac XPSAMF3742 230 Vac	XPSAPF5142 24 Vac/dc XPSAPF5342 48 Vac/dc XPSAPF3442 115 Vac XPSAPF3742 230 Vac
Product Type		XPSASF	XPSAMF	XPSAPF
Page Number		91	91	91

PREVENTA™ XPS Safety Relays

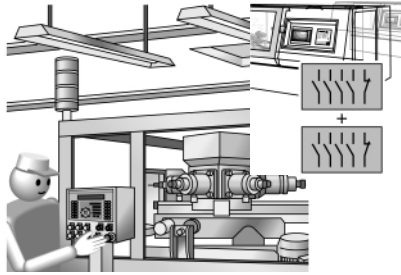
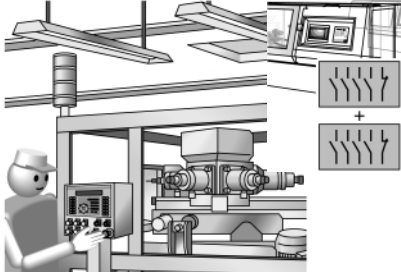
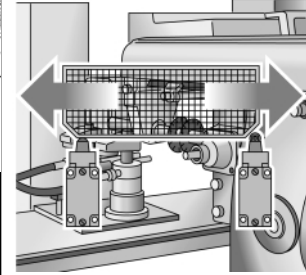
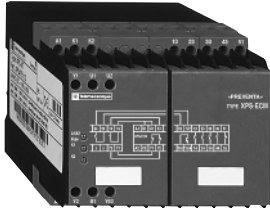
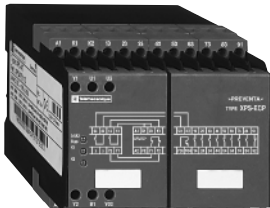
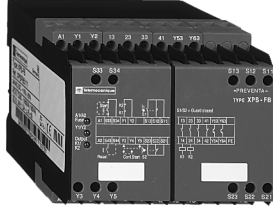

Selection Guide

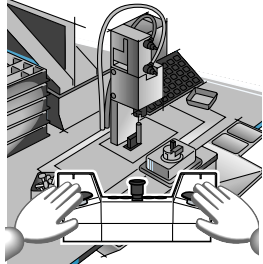
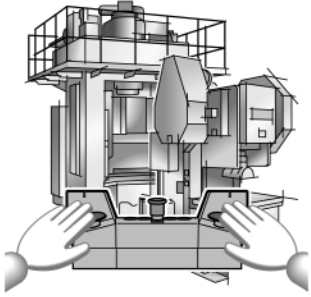
Applications				
Product Modules		For increasing the number of safety contacts		For electrical monitoring of pairs of limit switches
				
Conformity to Standards	Machine Assemblies	IEC 204-1, EN 292, EN 418, EN 60204-1		
	Product	EN 954-1 – Category 4		EN 954-1 – Category 4 EN 1088
Number of Circuits	Safety	4 N.O.	8 N.O.	3 N.O.
	Signaling	1 N.C. + 1 solid-state for messages to PLC		1 N.C. + 2 solid-state for messages to PLC
Indication		3 LEDs		
Supply Voltage		24 Vac/dc 115 Vac 230 Vac		24 Vac/dc 48 Vac/dc 115 Vac 230 Vac
Synchronization Time Between Inputs		—		1.5 s
Input Channel Voltage	24 V / 48 V Version	24 Vdc/—	24 Vdc	24/48 Vdc
	115 V / 230 V Version	24 Vdc/24 Vdc		48 Vdc
Catalog Number Shown With Module Supply Voltage		XPSECM5131 24 Vac/dc XPSECM3431 115 Vac XPSECM3731 230 Vac	XPSECP5131 24 Vac/dc XPSECP3431 115 Vac XPSECP3731 230 Vac	XPSFB5111 24 Vac/dc XPSFB5311 48 Vac/dc XPSFB3411 115 Vac XPSFB3711 230 Vac
Product Type		XPSECM		XPSECP
Page Number		98		103

PREVENTA™ XPS Safety Relays Selection Guide

Applications			
Product Modules		For electrical monitoring of two-hand control stations	
			
Conformity to Standards	Machine Assemblies	IEC 204-1, EN 292, EN 60204-1	IEC 204-1, EN 292, EN 60204-1
	Product	EN 954-1 – Category 1 EN 574 Type III A	EN 954-1 – Category 4 EN 574 Type III C
Number of Circuits	Safety	1 N.O.	2 N.O.
	Signaling	1 N.C.	1 N.C.
Indication		2 LEDs	3 LEDs
Supply Voltage		24 Vac/dc 115 Vac 230 Vac	24 Vdc 24 Vac 115 Vac 230 Vac
Synchronization Time Between Inputs		500 ms	500 ms
Input Channel Voltage	24 V / 48 V Version	24 Vdc	24 Vdc (24 Vdc modules) 48 Vdc (24 Vac modules)
	115 V / 230 V Version	24 Vdc	48 Vdc/48 Vdc
Catalog Number Shown With Module Supply Voltage		XPSBA5120 24 Vac/dc XPSBA3420 115 Vac XPSBA3720 230 Vac	XPSBC1110 24 Vdc XPSBC3110 24 Vac XPSBC3410 115 Vac XPSBC3710 230 Vac
Product Type		XPSBA	XPSBC
Page Number		107	107

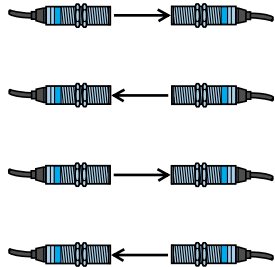
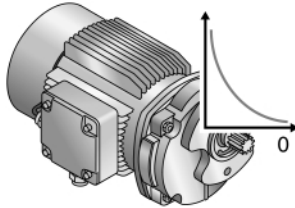
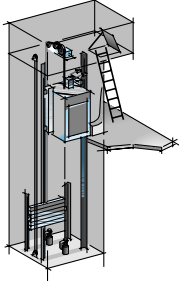
PREVENTA™ XPS Safety Relays Selection Guide

Applications				
Product Modules		For perimeter guarding	For zero speed detection	For elevator control
Functions				
Functions		Forms a "body" detection light curtain for perimeter guarding. Uses up to 4 XU2S thru-beam sensors.	Detection of motor zero speed by measuring the remnant voltage in the stator windings	Checks the position (height) of an elevator cabin when it stops at a landing, to help compensate for any differences made when loading or unloading.
Conformity to Standards	Machine Assemblies	IEC 204-1, EN 292, EN 60204-1	IEC 204-1, EN 292, EN 692 EN 60204-1	IEC 204-1, EN 292, EN 60204-1
	Product	EN 61496-1 – Type 2	EN 954-1 – Category 3 EN 1088	EN 954-1 – Category 4 EN 81-1, EN 81-2
Number of Circuits	Safety	2 N.O.	1 N.O. + 1 N.C.	2 N.O.
	Signaling	2 solid-state for messages to PLC	2 solid-state for messages to PLC	2 solid-state for messages to PLC
Indication		4 Led	2 LEDs	4 LEDs
Supply Voltage		24 Vac/dc	24 Vdc 115 Vac 230 Vac	24 Vac/dc 115 Vac 230 Vac
Catalog Number Shown With Module Supply Voltage		XPSCEN5141 24 Vac/dc XPSCPE5141 24 Vac/dc	XPSVN1142 24 Vdc XPSVN3442 115 Vac XPSVN3742 230 Vac	XPSDA5142 24 Vac/dc XPSDA3442 115 Vac XPSDA3742 230 Vac
Product Type		XPSCE	XPSVN	XPSDA
Page Number		113	120	127

PREVENTA™ XPS Safety Relays Selection Guide

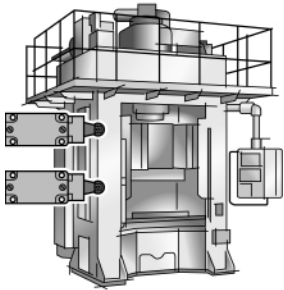
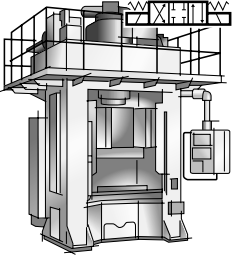
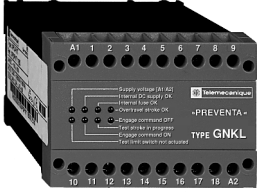
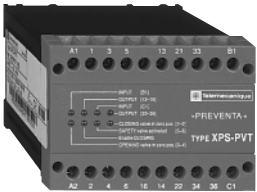
Applications			
Product Modules		For control of the braking travel of linear presses	For monitoring of solenoid valves on linear hydraulic presses
			
Functions		Automatic control of the braking distance of linear presses (for example: hydraulic, pneumatic, or screw presses).	Dynamic monitoring of the position of valve pistons in a hydraulic safety circuit on linear (hydraulic) presses.
Conformity to Standards	Machine Assemblies	IEC 204-1, EN 292, EN 693, EN 60204-1	IEC 204-1, EN 292, EN 693, EN 60204-1
	Product	EN 954-1 – Category 4	EN 954-1 – Category 4
Number of Circuits	Safety	3 N.O.	2 N.O. + 1 N.C.
	Signaling	1 N.C.	—
Indication		8 LEDs	8 LEDs
Supply Voltage		24 Vac/dc 120 Vac 230 Vac	24 Vdc — —
Catalog Number Shown With Module Supply Voltage		GNKL24VACDC 24 Vac/dc GNKL120VAC 120 Vac GNKL230VAC 230 Vac	XPSPVT1180 24 Vdc — —
Product Type		GNKL	XPSPVT
Page Number		130	133

PREVENTA™ XPS Safety Relays Selection Guide

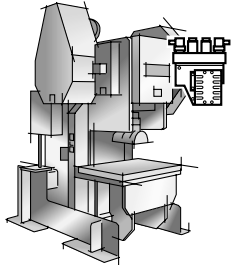
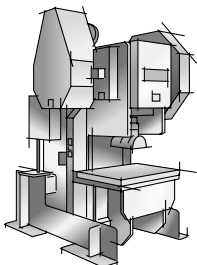
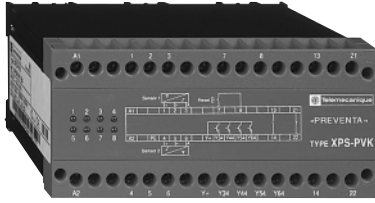
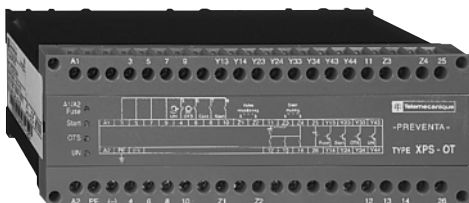
Applications			
Product Modules		For dynamic monitoring of double bodied solenoid valves	For stopping at TDC with automatic overtravel monitoring
			
Functions		Dynamic monitoring of double bodied safety solenoid valves on eccentric presses. It will not allow engagement of the clutch and engages the brake if a fault occurs in the solenoid.	Monitors the stopping distance at each cycle and maintained open function on eccentric presses.
Conformity to Standards	Machine Assemblies	IEC 204-1, EN 292, EN 692, EN 60204-1	IEC 204-1, EN 292, EN 692, EN 60204-1
	Product	EN 954-1 – Category 4	EN 954-1 – Category 4
Number of Circuits	Safety	1 N.O. + 1 N.C.	3 N.O.
	Signaling	4 solid-state for messages to PLC	4 solid-state for messages to PLC
Indication		8 LEDs	4 LEDs
Supply Voltage		24 Vdc 120 Vac 230 Vac	– 120 Vac 230 Vac
Catalog Number Shown With Module Supply Voltage		XPSPVK1184 24 Vdc XPSPVK3484 115 Vac XPSPVK3784 230 Vac	– XPSOT3444 115 Vac XPSOT3744 230 Vac
Product Type		XPSPVK	XPSOT
Page Number		136	141

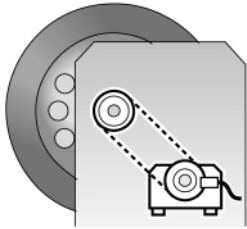
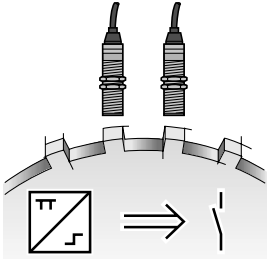
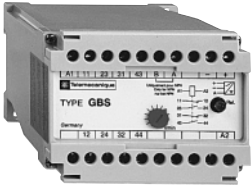
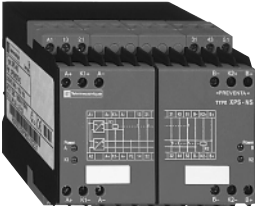
<p>Applications</p>		
<p>Product Modules</p>	<p>For shaft or chain break monitoring</p>	<p>Safety amplifier used with proximity sensors</p>
		
<p>Functions</p>	<p>Module for monitoring the mechanical transmission of movement between a cam shaft and the switching cams on eccentric presses</p>	<p>Detection and amplification of signals from limit switches, PNP and NPN proximity sensors. Converts signals to hard contacts.</p>
<p>Conformity to Standards</p>	<p>Machine Assemblies IEC 204-1, EN 292, EN 60204-1</p>	<p>IEC 204-1, EN 292, EN 60204-1</p>
<p>Product</p>	<p>—</p>	<p>EN 954-1 – Category 4</p>
<p>Number of Circuits</p>	<p>Safety 2 N.O. + 2 N.C.</p>	<p>2 N.O. + 2 N.C.</p>
<p>Signaling</p>	<p>—</p>	<p>4 N.C.</p>
<p>Indication</p>	<p>1 LED</p>	<p>4 LEDs</p>
<p>Supply Voltage</p>	<p>— 120 Vac 230 Vac</p>	<p>— 120 Vac 230 Vac</p>
<p>Catalog Number Shown With Module Supply Voltage</p>	<p>GBS120VAC 120 Vac GBS230VAC 230 Vac GBS120VACINF 120 Vac GBS230VACINF 230 Vac</p>	<p>— XPSNS3440 115 Vac XPSNS3740 230 Vac</p>
<p>Product Type</p>	<p>GBS</p>	<p>XPSNS</p>
<p>Page Number</p>	<p>143</p>	<p>145</p>



Safety Relay Modules for Micro and Premium PLC's

Safety relay modules are also available for the Micro and Premium PLC platforms. These modules perform the same function as the XPS safety relays and plug into the Micro and Premium platforms. The safety module operation is independent of the PLC processor. For more information, please contact your local Schneider Electric Industrial Sales representative.

PREVENTA™ XPS Safety Relays

Overview

Safety

Good equipment is **safe** equipment, which combines:

- **Safety:** of personnel (equipment that does not pose a hazard),
- **Reliable Operation:** of production machinery (equipment in working order at all times).

Safety is achieved by:

- Simultaneously optimizing safety and reliability,
- Applying fundamental principles: redundancy, and self-testing,
- Making reliability a design consideration (failure potential determining the design of the machine in a specified position, pro-active safety features),
- Ease of maintenance.

Safety and Automation

All hazardous areas must be identified and their access restricted and controlled, that is to say that no failure or tampering should render the automated equipment hazardous to personnel.

Please note that the use of safety products does not necessarily assure the equipment is compliant with the European Machinery Safety Directive, CSA, OSHA, ANSI, or other Canadian safety requirements.

Rather, proper use, wiring, connections and planning contribute to the safety of the equipment as a whole.

Safety systems are comprised of many components. No one safety component will ensure the safety of the system. The design of the complete safety system should be considered before you begin. It is very important to follow applicable safety standards when installing and wiring these components.

General Model of an Automated Machine

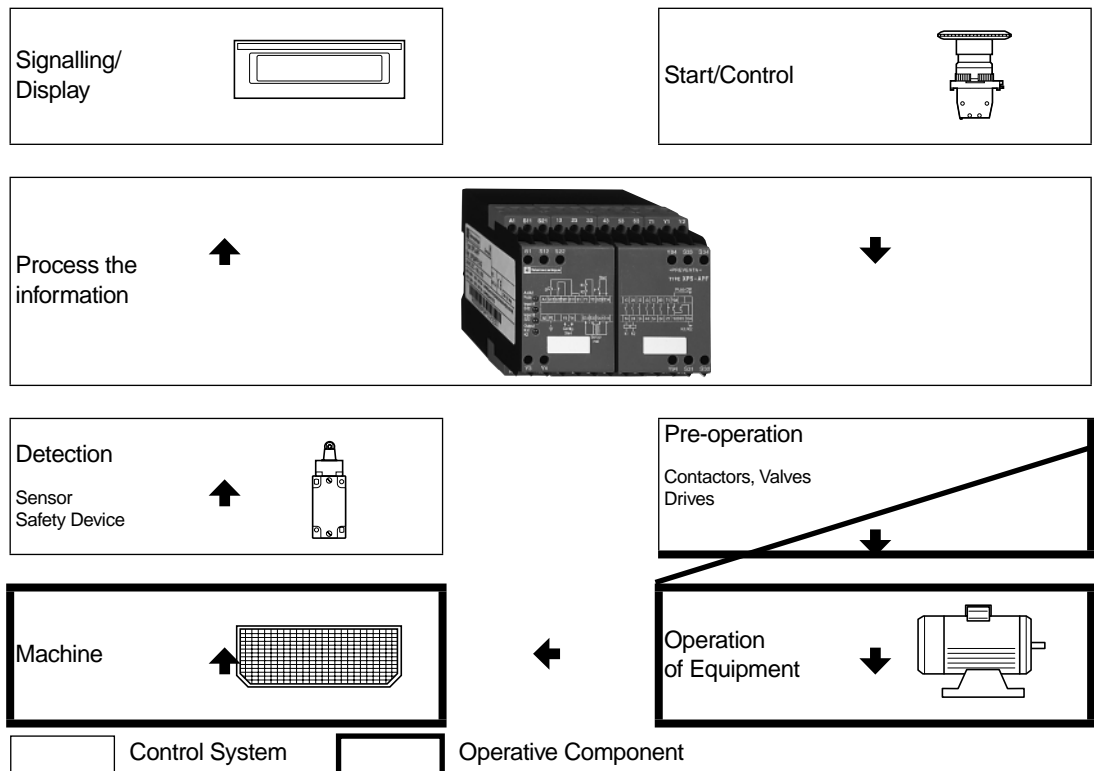

OBJECTIVE

- Open outputs upon occurrence of the first fault.
- Provide non-hazardous positioning.
- Enhance the safety of personnel operating industrial machinery.

BASIC PRINCIPLES

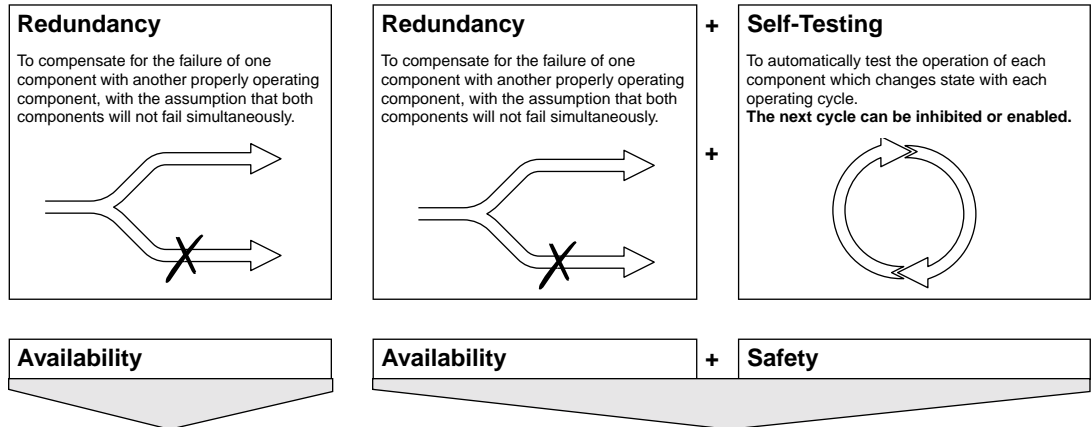

If an initial fault is not detected, there is no corrective action, allowing a second fault to occur, thereby compromising safety.

An initial fault in a safety circuit will be detected before a second fault can occur (next cycle inhibited).

The use of a PREVENTA safety relay module allows a Category 4 control system to be designed in compliance with standard EN 954-1 (for safety-related control system components).

DEFINITIONS

Redundancy

This function is achieved by integrating dual circuitry into the design, combined with a test function which authorizes a control action only when at least two output signals are identical.

Self-Test Function

PREVENTA safety relay modules use mechanically-linked N.O. and N.C. contact relays.

These relays ensure the uniform operation of their additional N.C. and N.O. contacts.

The reliability of the self-test function is ensured by verifying the proper operation of the contact relays during the current cycle.

To detect the failure of a mechanically-linked N.O. relay contact requires that the proper operation of its N.C. contacts be tested at the time of their integration into a self-test circuit. This detection is made possible only by using mechanically-linked contact relays.

PREVENTA™ XPS Safety Relays

Interposing Relay Concepts

Effect on the Control Circuit without Interposing Relays/Contactors

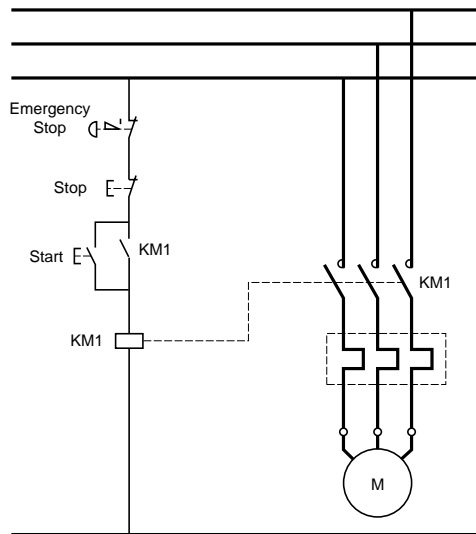

The control signal issued by the protective device (emergency stop circuit illustrated to the left) acts directly on the power contactor of the machine.

In this diagram, the possible fault conditions are:

- emergency stop button being shorted or jumpered.
- KM1 contactor sticking or welded.

When the emergency stop is operated, the signal is not recognized, and another sequence can begin following the emergency stop, despite the presence of the fault condition.

In this case of failure, the safety function[▲] is compromised. Therefore, reliable interposing relays/contactors must be used.

[▲] A safety function is a function whose non-execution or untimely execution results in the immediate placement of the equipment into a non-hazardous condition.

Effect on the Control Circuit with Interposing Relays/Contactors

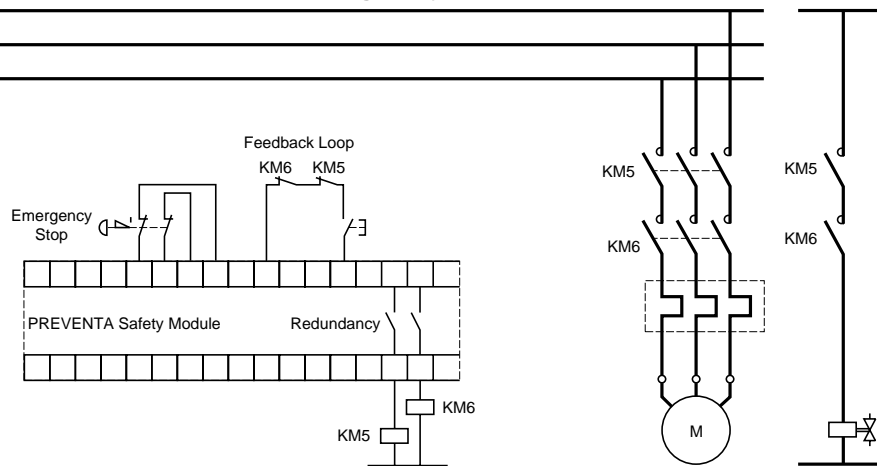

KM5 and KM6 Relays/Contactors with Mechanically-Linked Contacts

Independent Safety Circuits

PREVENTA safety relay modules provide **reliable** interposing relaying by eliminating the risks of a:

- control circuit fault (inputs),
- power circuit fault (outputs),
- safety module internal component fault.

The safety function remains operative in all occurrences of one of these faults.

Relays and Contactors in the Safety Circuit

Use relays or contactors with mechanically-linked contacts on the safety outputs of the safety relay such as the Square D or Telemecanique products found in Appendix A, pages 174-177, of this catalog.

Category requirements

To meet the requirements of Category 3 per EN 954-1 (this standard deals with safety related parts of control systems), the output devices must be redundant - meaning there must be two relays/contactors in series controlling the load which can cause a hazardous movement. Using only one relay/contactors will reduce the control system to a **maximum Category 2**.

To meet the requirements of Category 4 per EN 954-1, the requirements for Category 3 need to be met, **plus** one of the N.C. auxiliary contacts from **each** of the two relays/contactors in series must be wired in series in the feedback loop. Without both of these N.C. contacts wired in series in the feedback loop, the control system is reduced to a **maximum Category 3**.

PREVENTA™ XPS Safety Relays

Safety Solutions: Applications for Protection Systems and Gates or Guards

SELECTION CRITERIA

Low Potential of Hazard to Personnel

Locking or interlocking device based on the principle of intrinsically safe design (proven components and principles).

Quick-Stop Machinery. Locking (stop time < access time) *

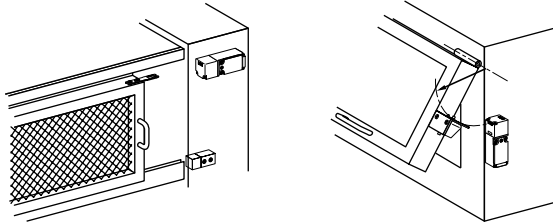

Locking by actuating key

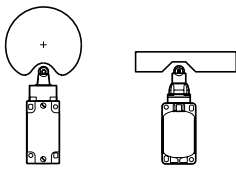

Positive Mode Activation

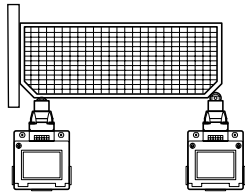

Positive and Negative Mode Activation

High Potential of Hazard to Personnel

Locking or interlocking device based on redundancy and self-testing. The safety relay modules provide these functions.

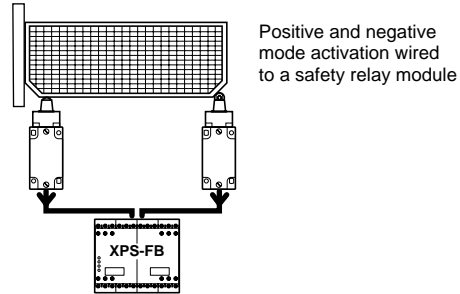

Positive and negative mode activation wired to a safety relay module

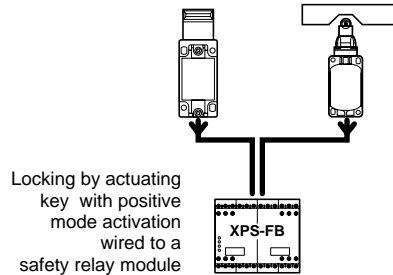

Locking by actuating key with positive mode activation wired to a safety relay module

Inertia-Based Machinery; Long Stopping Times. Interlocking (stop time > access time)*

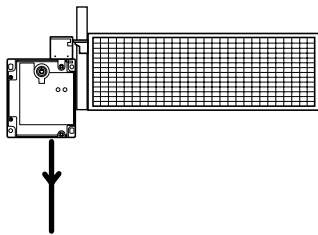

Interlocking Device with Electromagnetic Guard Lock

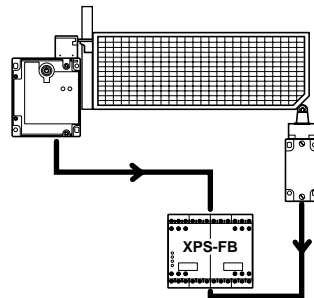

Interlocking Device with Electromagnetic Guard Lock

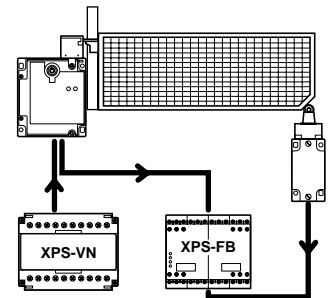

Interlocking Device with Electromagnetic Guard Lock and Zero Speed Sensing

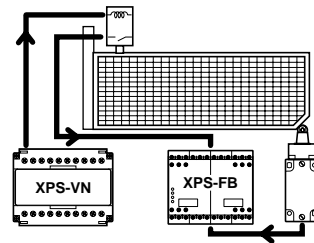

Interlocking Device with Electromagnetic Lock

* Stop time: time elapsed between issuance of the machine stop command and the moment at which the machine stops (risk elimination). Access time: time required for a person to access the hazardous area (calculated using an approach speed as the basis).

PREVENTA™ XPS Safety Relays

Rating Curves

Lifetime Curve and Switching Capability with N.O. Contacts

determined by EN 60947-5-1 Table C2

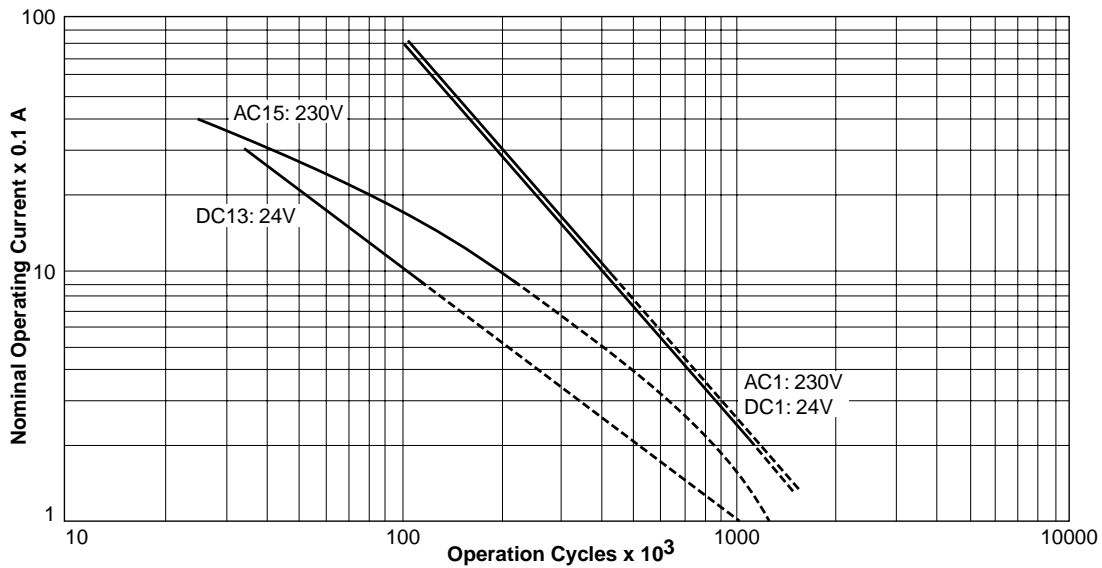

XPSAL, XPSAS, XPSASF, XPSAT (time delayed contacts), XPSAX, XPSBA, XPSBC, XPSCE, XPSDA, XPSFB, XPSNS, XPSOT, XPSPVK, XPSPVT, XPSVN, GNKL, GLA, GLC, DANZ, DEWZ

Lifetime Curve and Switching Capability with N.O. Contacts

determined by EN 60947-5-1 Table C2

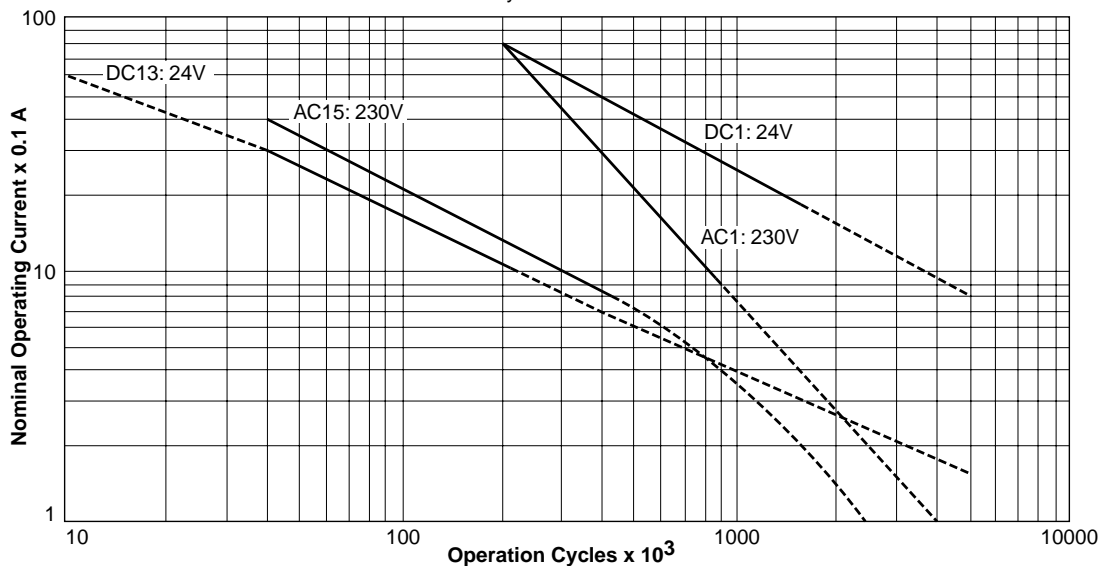

XPSAT (direct contacts), XPSAM, APSAMF, XPSAP, XPSAPF, XPSECM, XPSECP, GBS

The product life expressed above is based on average usage and normal operating conditions. Actual operating life will vary with conditions. The above statements are not intended to nor shall they create any express or implied warranties as to product operation or life. For information on the limited warranty offered on this product please refer to the Schneider Electric terms and conditions of sale.

PREVENTA™ XPS Safety Relays Electrical Ratings

Determining the electrical life according to EN 60947-5-1 (table C2)

Type of current	Utilization category	Start-up			Breaking		
		Current	Voltage	Cos φ	Current	Voltage	Cos φ
AC supply	AC-15	10 x I _e	U _e	0.7	I _e	U _e	0,4
Type of current	Utilization category	Start-up			Breaking		
		Current	Voltage	T 0.95	Current	Voltage	T 0.95
DC supply	DC-13	I _e	U _e	50 ms	I _e	U _e	50 ms

I_e: Operational current measured.
 U_e: Operational voltage measured.
 Cos φ : Power factor.
 T 0.95: Time taken to reach 95% of rated current.

The tests are carried out with a frequency of 6 switching operations per minute and with no additional protection of the components connected to the safety outputs.

The use of additional protection for the components connected to the safety outputs significantly increases the life of the safety outputs.

Determining the breaking capacity according to EN 60947-5-1 (table 4)

Utilization cat.	Start-up			Breaking			Total no. of switching ops.	Switching ops. per minute for 1...1000 switching ops.	Switching ops. per minute for 1001...6050 switching ops.	Minimum duration of switching operation
	Current	Voltage	Cos φ	Current	Voltage	Cos φ				
AC-15	10 x I _e	U _e	0.3	I _e	U _e	0.3	6050	60	6	50 ms
Utilization cat.	Start-up			Breaking			Total no. of switching ops.	Switching ops. per minute for 1...1000 switching ops.	Switching ops. per minute for 1001...6050 switching ops.	Minimum duration of switching operation
	Current	Voltage	T 0.95	Current	Voltage	T 0.95				
DC-13	I _e	U _e	50 ms	I _e	U _e	50 ms	6050	60	6	50 ms

I_e: Operational current measured.
 U_e: Operational voltage measured.
 Cos φ : Power factor.
 T 0.95: Time taken to reach 95% of rated current.

Comments:

The maximum values for the breaking capacity of the safety outputs in the various utilization categories are not fixed and depend on the power factor and on the switching frequency. The test definition for the “breaking capacity” and “durability” tables in European standard EN 60947-5-1 uses different values for the power factor and the switching frequency.

The power factor (cos φ) in the “breaking capacity” table (0.3) is greater than that in the “durability” table (0.7)

The switching frequency of the safety outputs is higher in the “breaking capacity” table (60 switching operations per minute for the first 1000 switching operations) than in the “durability” table (6 switching operations per minute).

Consequently, the maximum breaking capacity values determined using the “breaking capacity” table are lower than those in the “durability” table.

AC Voltage and Current Ratings 50-60 Hz

Contact Rating Designation	Thermal Continuous Test Current, Amperes	Maximum Current, Amperes								Volt amperes	
		120 Volts		240 Volts		480 Volts		600 Volts		Make	Break
		Make	Break	Make	Break	Make	Break	Make	Break		
B300	5	30	3.00	15	1.50	3600	360
C300	2.5	15	1.50	7.5	0.75	1800	180

PREVENTA™ XPS Safety Relays

Emergency Stop and Limit Switch Monitoring

Technical Data

Module Type		XPSAL	XPSAX	XPSAT
Power Supply Voltage	V	24 AC and DC, 115 AC, 230 AC	24 AC and DC	24 AC and DC, 115 AC, 230 AC
Voltage limits		- 10...+10 % (24 V) - 15...+15 % (115 V) - 15...+10 % (230 V)	- 20...+10 % (AC) - 20...+ 20 % (DC)	- 20...+ 10 % (24 V) - 15...+ 15 % (115 V) - 15...+ 10 % (230 V)
Frequency	Hz	50/60	50/60	50/60
Power Consumption	VA	< 3	< 5	< 8
Module Fuse Protection		≤ 4 A external fuse	≤ 4 A external fuse	≤ 4 A external fuse for 24 V versions, internal electronic for 115 V and 230 V versions
Selectable Delay	s	–	–	0 to 30
Start Button Monitoring		No	No	Yes (configurable by jumpering terminal connections)
Control Component Voltage - 24 V Version - 48 V, 115 V, and 230 V Versions	V	Identical to supply voltage 24 (approx. 60 mA) 115/230 (approx. 20 mA)	Identical to supply voltage 24 (approx. 60 mA)	Between terminals S11-S12 and S21-S22 or S11-B1 24 Vdc 48 Vdc (115 V, 230 V)
Minimum Voltage and Current Between Terminals S11-S12 and S21-S22 or S11-B1 (inputs A and B) U min/I min - 24 V (20 °C) version U min/I min - 115 V/230 V (20 °C) version		– –	– –	17 V/25 mA 38 V/15 mA
Calculation of the Wiring Resistance RL between terminals S11-S12, S21-S22 or S11-B1 as a function of the internal power supply voltage U int (terminals S11-S21)	Ω	–	U int = Supply voltage	$RL_{max} = \frac{U_{int} - U_{min}}{I_{min}}$ Ue = True voltage applied to terminals A1-A2 U int = Supply voltage Ue - 3 V (24 V version) U int between 42 V and 45 V, with typical value = 45 V (115 V, 230 V version) Calculated max RL must be equal to or greater than the true value
Synchronization Time Between Inputs A and B automatic start, jumpered terminals S33-Y2 and Y3-Y4	ms	–	–	Approximately 75 ms
Outputs Voltage reference		Relay hard contacts		
No. and nature of standard safety output circuits		2 N.O. (13-14, 23-24)	3 N.O. (13-14, 23-24,33-34)	3 N.O. (13-14, 23-24,33-34)
No. and nature of time delay safety circuits		–	–	2 N.O. (57-58, 67-68)
No. and nature of additional circuits		–	1 N.C. (41-42)	1 N.C. (41-42)
AC-15 Breaking capacity non-time delay outputs time delay outputs	VA	C300: inrush 1800, sealed 180 –	C300: inrush 1800, sealed 180 –	B300: inrush 3600, sealed 360 C300: inrush 1800, sealed 180
DC-13 Breaking capacity non-time delay outputs time delay outputs		24 V/1.25 A L/R = 50 ms –	24 V/1.25 A L/R = 50 ms –	24 V/1.5 A L/R = 50 ms 24 V/1.5 A L/R = 50 ms
Max thermal current (Ithe) non-time delay outputs time delay outputs	A	2.5 –	6 –	5 2.5
Output fuse protection per IEC 947-5-1, DIN VDE 0660 Part 200 non-time delay outputs time delay outputs	A	4 A fuse –	≤ 4 A fuse or 6 A fast blow for outputs 23-24 or 33-34 –	6 A fuse 4 A fuse
Minimum current	mA	10		
Minimum voltage	V	17		
Electrical Life		See page 78		
Response Time from Input Breaking	ms	< 100	< 40	< 20
Rated Insulation Voltage (Ui)	V	300 (Pollution degree 2 per IEC 947-5-1, DIN VDE 0110 parts 1 and 2)		
Rated Impulse Withstand Voltage (Uimp.)	kV	4 (Overvoltage Category III, per IEC 947-1, DIN VDE 0110 Parts 1 and 2)		
LED Display		2	4	4
Operating Temperature		+ 14 °F to + 130 °F (- 10 °C to + 55 °C)		
Storage Temperature		- 13 °F to + 185 °F (- 25 °C to + 85 °C)		
Degree of Protection per IEC 529 Terminals		IP 20		
Housing		IP 40		
Connection Type		Captive screw-clamp terminals. Maximum wire size: 1-12 AWG (1 x 4 mm ²) without cable end, 2-14 AWG (2 x 2.5 mm ²) with cable end		

PREVENTA™ XPS Safety Relays Emergency Stop and Limit Switch Monitoring

OPERATING PRINCIPLE



XPSAL

PREVENTA XPSA emergency stop and limit switch monitoring modules are used to interrupt one or several circuits and are designed to be used in emergency stop or safety circuits, in accordance with standard EN 60204-1. They meet the requirements of European standard EN 418 for emergency stops and EN 60204-1 for safety circuits. These standards apply especially to cases in which a single emergency stop command must interrupt several circuits (indirect action emergency stop).

These modules also meet the safety requirements for electronic monitoring of limit switches in protection devices.

XPSAL Module

The XPSAL module has two stop-category 0, N.O. output circuits.



XPSAX

XPSAX Module

The XPSAX module has 3 stop category 0, N.O. output contacts and 1 N.C. auxiliary contact.

XPSAT Module

In addition to the three stop-category 0, N.O. safety outputs, the XPSAT module has two other stop-category 1 time delay outputs, which allow for controlled slow down of the motor components until a complete stop is reached (for example, motor braking by a variable speed drive). At the end of the preset delay, the power supply is disconnected by opening the time-delay output circuits. The time delay of the two output circuits between terminals 57-58 and 67-68 (see wiring and connection diagrams, pages 83 and 84) can be set from 0 to 30 seconds using the 12-position selector switch on the cover of the XPSAT.

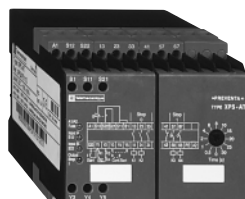

XPSAT

XPSASF, XPSAMF, and XPSAPF Modules

Safety modules XPSASF, XPSAMF and XPSAPF can also be used for pressure sensitive mats and edge sensors.

Ordering Information

Description		No. of Standard Safety Circuits	No. of Time Delay Safety Circuits	Power Supply	Catalog Number	Weight oz. (kg)
Safety Modules for Emergency Stop and Limit Switch Monitoring	XPSAL: Suitable for use in circuits through Category 3 per EN 954-1	2	-	24 Vac/dc	XPSAL5110	7 (0.200)
				115 Vac	XPSAL3410	7 (0.200)
				230 Vac	XPSAL3710	7 (0.200)
	XPSAX: Suitable for use in circuits through Category 3 per EN 954-1	3	-	24 Vac/dc	XPSAX5120	9 (0.250)
	XPSAT: Suitable for use in circuits per EN 954-1: Category 4 for instantaneous contacts Category 3 for timed contacts	3	2	24 Vac/dc	XPSAT5110	23 (0.650)
				115 Vac	XPSAT3410	30 (0.850)
230 Vac				XPSAT3710	30 (0.850)	



File E164353
CCN NKCR



File LR44087
Class 3211 03



Dimensions 147-148

PREVENTA™ XPS Safety Relays

Emergency Stop and Limit Switch Monitoring

Wiring Diagrams and Connections

XPSAL Module with an Emergency Stop Button

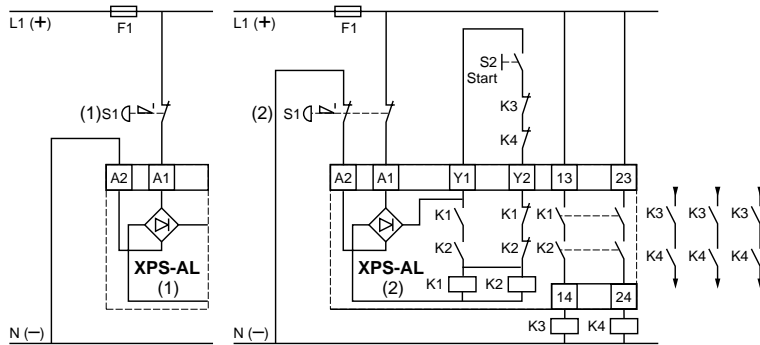

- (1) Emergency stop button with 1 N.C. contact
- (2) Emergency stop button with 2 N.C. contacts (recommended application)
- Y1-Y2: Feedback loop

XPSAL Functional Diagram

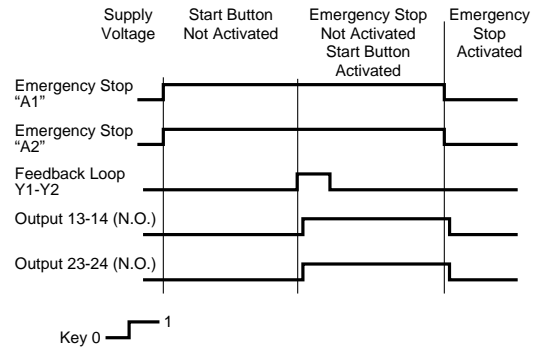

XPSAX Module with an Emergency Stop Button

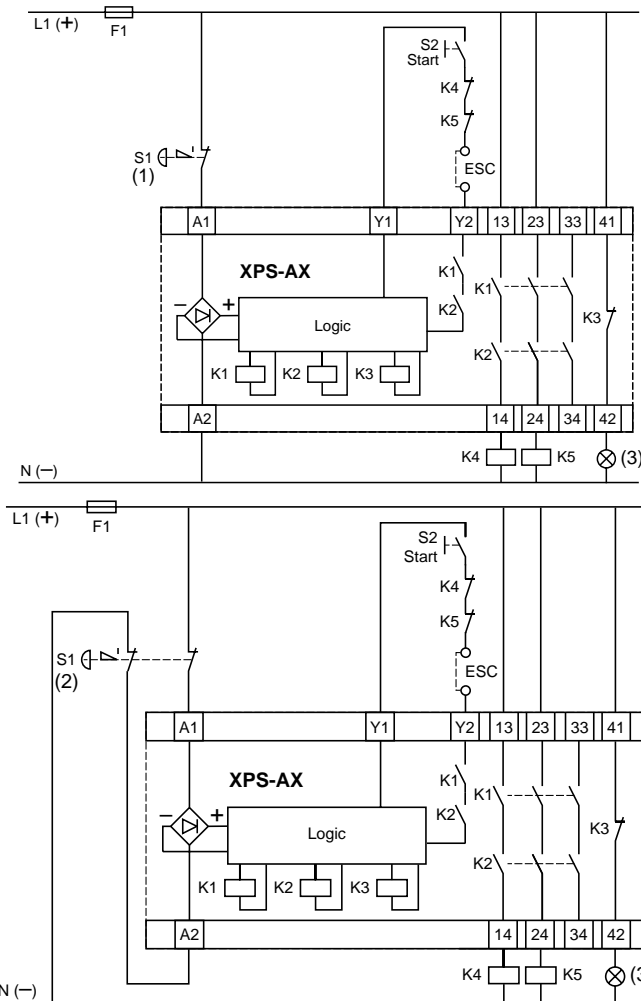

- (1) Emergency stop button with 1 N.C. contact
- (2) Emergency stop button with 2 N.C. contacts (recommended application)
- (3) "Emergency stop" signaling
- Y1-Y2: Feedback loop
- ESC: External start conditions

XPSAX Functional Diagram

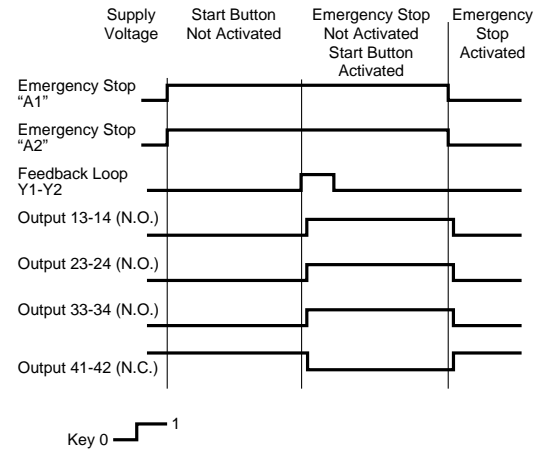

XPSAL and XPSAX LED Signals

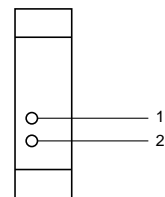

- 1 A1-A2 supply voltage
- 2 Status of K1-K2 (N.O. safety outputs closed)

PREVENTA™ XPS Safety Relays Emergency Stop and Limit Switch Monitoring

Wiring Diagrams and Connections XPSAT Module with an Emergency Stop Button

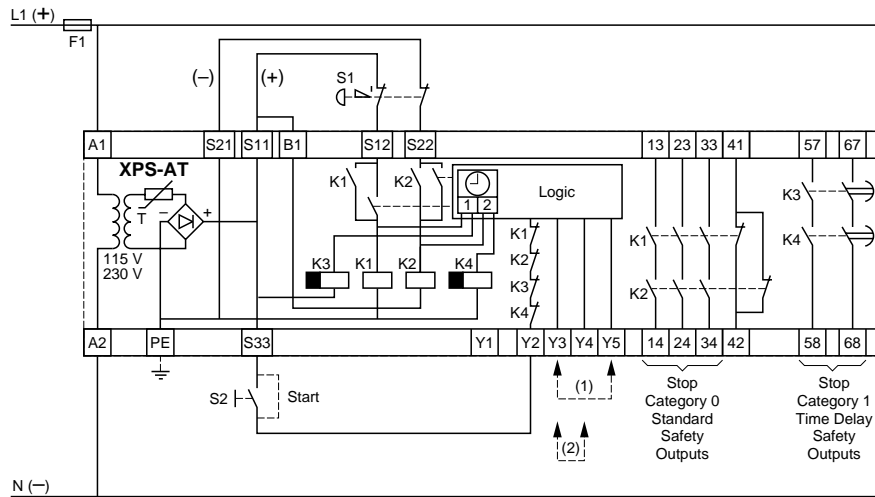

S1: Emergency stop button with 2 N.C. contacts (recommended application).

Output 41-42 must not be used as a safety circuit.

- (1) With start button monitoring
- (2) Without start button monitoring
- (3) Dashed line around S2 (N.O. start button between terminals S33-Y2) indicates wiring for automatic start. This is only feasible when configured without start button monitoring. If S2 is jumpered and the module is configured for start button monitoring, the N.O. safety contacts will not close.

Functional Diagram for XPS-AT Module with Emergency Stop Monitoring

Functional Diagram for XPS-AT Module with Limit Switch Monitoring

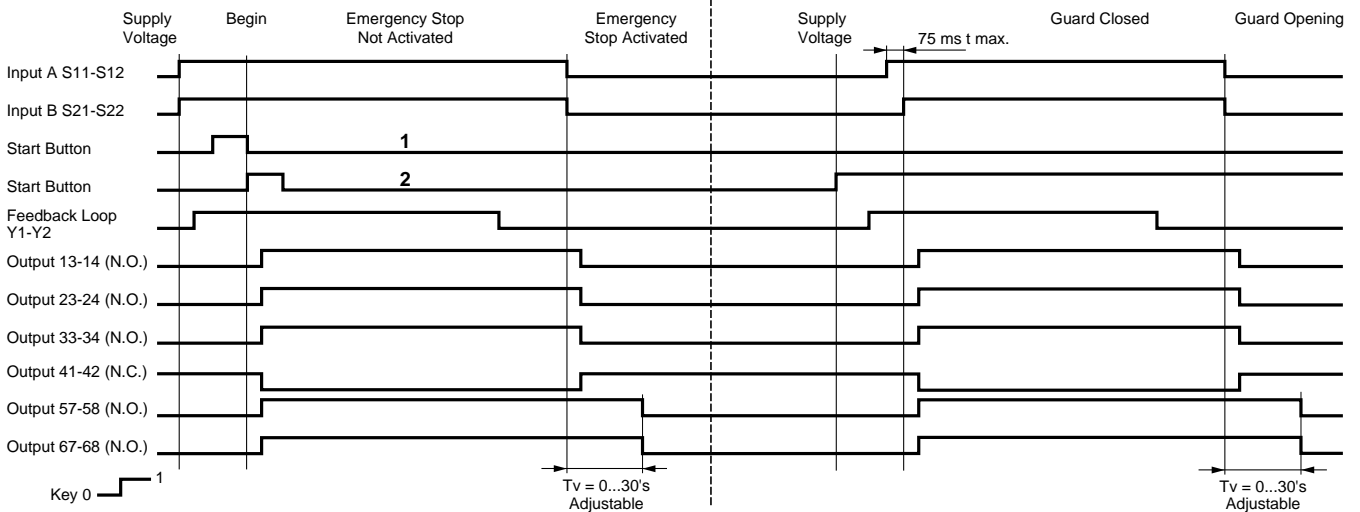

- 1 With start button monitoring (connection Y3-Y5)
- 2 Without start button monitoring (connection Y3-Y4)

XPSAT LED Signals

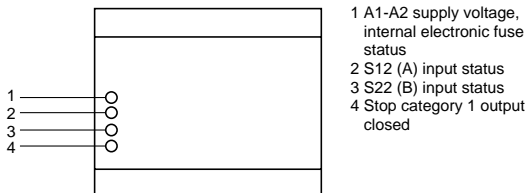

PREVENTA™ XPS Safety Relays

Emergency Stop and Limit Switch Monitoring

Wiring Diagrams and Connections

XPSAT Module

Example of a safety circuit connecting an emergency stop module with a variable speed drive controller

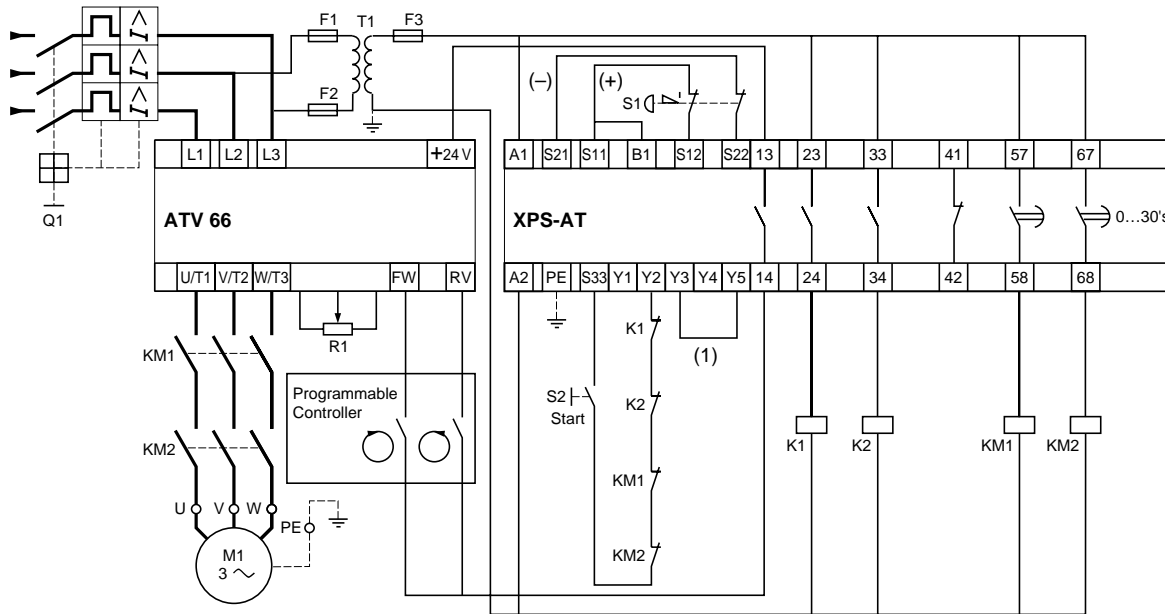

(1) With start button monitoring
S1: Emergency stop button with 2 N.C. contacts (recommended application)

XPSAT

Configuration with 1 Emergency Stop Button

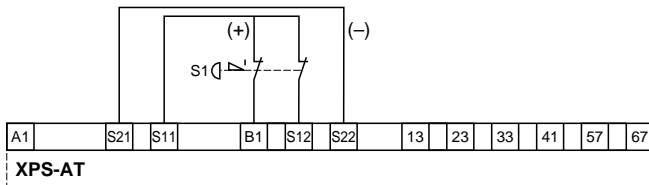

Both input channels are supplied the same voltage.
S1: 2-contact emergency stop button
(short circuits between the 2 inputs are not detected).

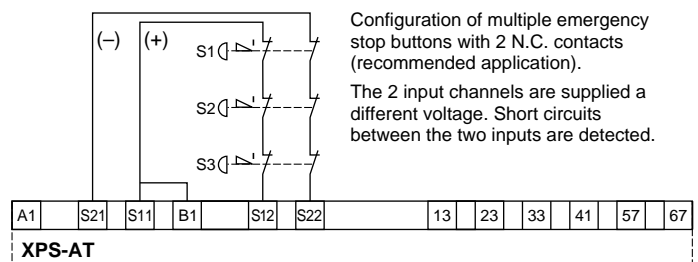

Configuration of multiple emergency stop buttons with 2 N.C. contacts (recommended application).
The 2 input channels are supplied a different voltage. Short circuits between the two inputs are detected.

XPSAT

Configuration with Start Button Monitoring
(Start button 1 functional diagram, see page 83)

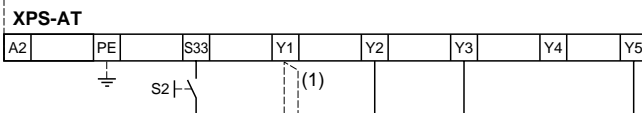

Configuration without Start Button Monitoring
(Start button 2 functional diagram, see page 83)

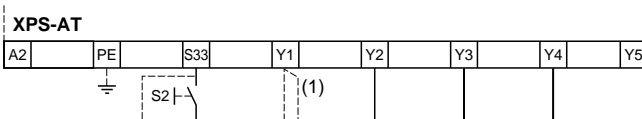

(1) Auxiliary terminal (to be used to separate the feedback loop from the wiring)

Monitoring for a Single-Contact Emergency Stop Button

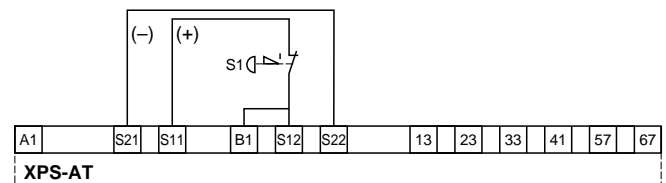

S1: Emergency stop button with 1 N.C. contact.
Not all faults are detected: short-circuits on the emergency stop push button are not detected.

PREVENTA™ XPS Safety Relays Emergency Stop and Limit Switch Monitoring

Technical Data

Module Type		XPSAS	XPSAM	XPSAP
Power Supply Voltage	V	24/48 Vac/dc, 115/230 Vac		
Voltage Limits		- 20...+10 % Vdc, + 20 % (24/48 Vac) - 15...+15 % (115 Vac) - 15...+10 % (230 Vac)		
Frequency	Hz	50/60		
Power Consumption 24 V 48 V 115 V/230 V	VA	< 4 < 4 < 6		< 7 < 7 < 10
Module Fuse Protection		≤ 4 A external fuse for 24 V and 48 V versions, internal electronic for 115 V and 230 V versions		
Voltage on Control Unit between S11-S12, S21-S22 or S11-B1	V	24 Vdc (24 V version), 48 Vdc (48 V, 115 V and 230 V versions)		
Minimum Voltage and Current Between Terminals S11-S12, S21-S22 or S11-B1 (inputs A and B)				
U min/I min - 24 V (20 °C) version		16 V/70 mA	16 V/60 mA	16 V/100 mA
U min/I min - 48 V (20 °C) version		35 V/35 mA	35 V/25 mA	35 V/45 mA
U min/I min - 115 V/230 V (20 °C) version		41 V/35 mA	41 V/25 mA	41 V/45 mA
Calculation of Wiring Resistance RL Between Terminals S11-S12, S21-S22 or S11-B1 as a function of the internal supply voltage (U int) (terminals S11-S21)	Ω	$RL_{max} = \frac{U_{int} - U_{min}}{I_{min}}$ Ue = true voltage applied to terminals A1-A2 U int = supply voltage Ue - 3 V (24 V, 48 V version) U int between 42 V and 45 V, with typical value = 45 V (115 V, 230 V version) Max RL must not exceed 50 Ω		
Synchronization Time Between Inputs A and B automatic start, jumpered terminals S33-S34	ms	Approximately 300		
Outputs Voltage reference		Relay hard contacts		
No. and nature of safety circuits		2 N.O. (13-14, 23-24)	3 N.O. (13-14, 23-24, 33-34)	6 N.O. (13-14, 23-24, 33-34, 43-44, 53-54, 63-64)
No. and nature of additional circuits		–	1 N.C. (41-42)	1 N.C. (71-72)
AC-15 Breaking capacity	VA	C300: inrush 1800, sealed 180	B300: inrush 3600, sealed 360	
DC-13 Breaking capacity		24 V/1.5 A - L/R = 50 ms		
Max thermal current (Ithe)	A	5	6	
Output fuse protection per IEC 947-5-1, DIN VDE 0660 Part 200	A	4 A fuse	6 A fuse	
Minimum current	mA	10		
Minimum voltage	V	17		
Electrical Life		See page 78		
Response Time from Input Breaking	ms	< 40		
Rated Insulation Voltage	V	300 (Pollution degree 2 per IEC 947-5-1, DIN VDE 0110 Parts 1 and 2)		
Rated Impulse Withstand Voltage (Uimp)	kV	4 (Overvoltage category III, per IEC 947-1, DIN VDE 0110 Parts 1 and 2)		
LED Display		4		
Operating Temperature		+ 14 °F to + 130 °F (- 10 °C to + 55 °C)		
Storage Temperature		- 13 °F to + 185 °F (- 25 °C to + 85 °C)		
Degree of Protection per IEC 529 Terminals Housing		IP 20 IP 40		
Connection Type		Captive screw-clamp terminals. Maximum wire size: 1-12 AWG (1 x 4 mm ²) without cable end, 2-14 AWG (2 x 2.5 mm ²) with cable end		

PREVENTA™ XPS Safety Relays

Emergency Stop and Limit Switch Monitoring



XPSAS

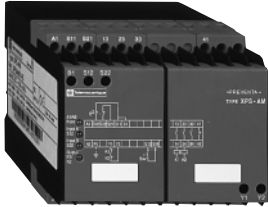

XPSAM

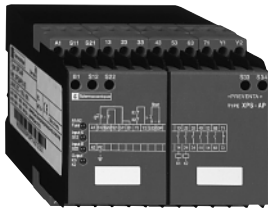

XPSAP

Ordering Information

Description	No. of Safety Circuits	Power Supply	Catalog Number	Weight oz. (kg)
Safety Modules for emergency stop and limit switch monitoring	2	24 Vac/dc	XPSAS5140	12 (0.350)
		48 Vac/dc	XPSAS5340	12 (0.350)
		115 Vac	XPSAS3440	16 (0.450)
		230 Vac	XPSAS3740	16 (0.450)
	3	24 Vac/dc	XPSAM5140	21 (0.600)
		48 Vac/dc	XPSAM5340	21 (0.600)
		115 Vac	XPSAM3440	25 (0.700)
		230 Vac	XPSAM3740	25 (0.700)
	6	24 Vac/dc	XPSAP5140	21 (0.600)
		48 Vac/dc	XPSAP5340	21 (0.600)
		115 Vac	XPSAP3440	25 (0.700)
		230 Vac	XPSAP3740	25 (0.700)

Suitable for use in circuits through Category 4 per EN954-1.



File E164353
CCN NKCR



File LR44087
Class 3211 03



Dimensions 147-148

PREVENTA™ XPS Safety Relays Emergency Stop and Limit Switch Monitoring

Wiring Diagrams and Connections

XPSAS

XPSAS module with a 2-N.C.-contact emergency stop button

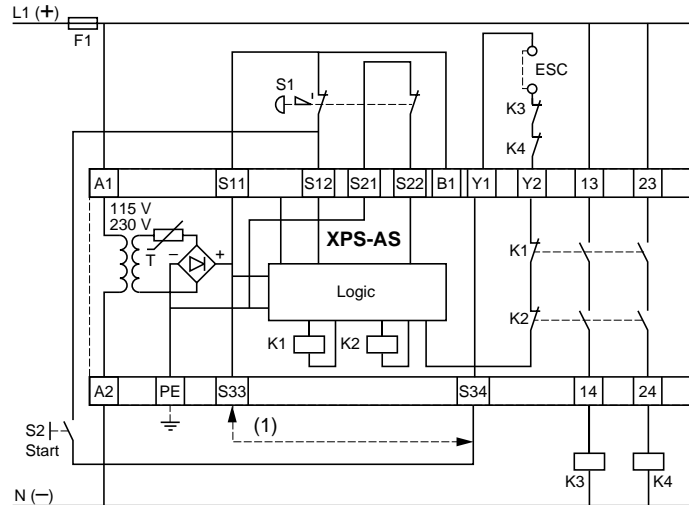

ESC: External Start Conditions
Y1-Y2: Feedback loop
(1) Wiring for automatic start (S33-S34)

LED Signals

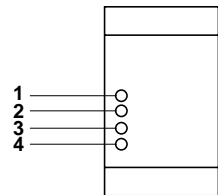

- 1 A1-A2 supply voltage, internal electronic fuse status
- 2 Input S12 (A)
- 3 Input S22 (B)
- 4 K1/K2 status (N.O. safety outputs closed)

XPSAS Functional Diagrams

Emergency Stop Function

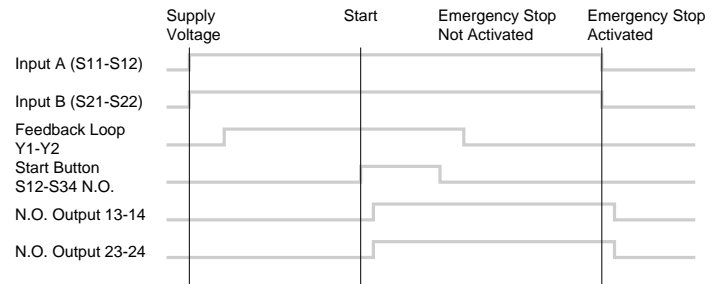

Legend 0 1

Limit Switch Monitoring with Automatic Start Function

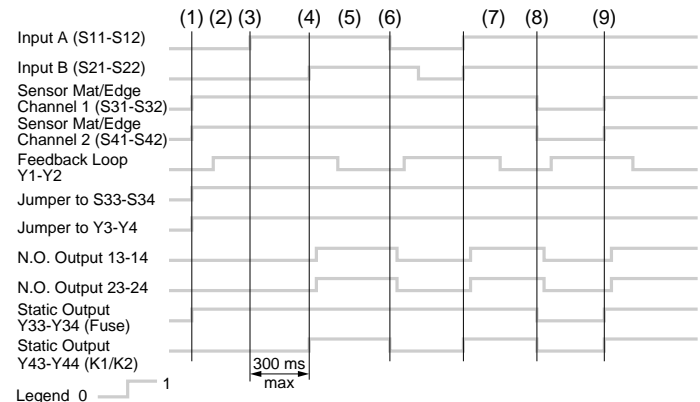

Legend 0 1

PREVENTA™ XPS Safety Relays

Emergency Stop and Limit Switch Monitoring

Wiring Diagrams and Connections

XPSAM

XPSAM module with a 2-N.C.-contact emergency stop button

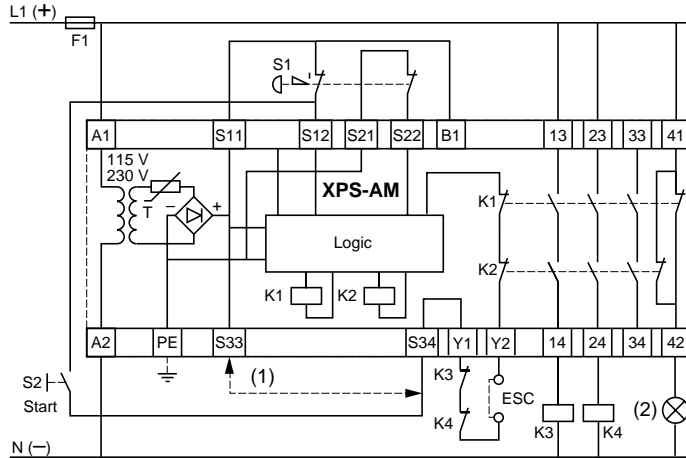

ESC: External Start Conditions

Y1-Y2: Feedback loop

(1) Wiring for automatic start (S33-S34)

(2) Signalling output (41-42) (not a safety output)

LED Signals

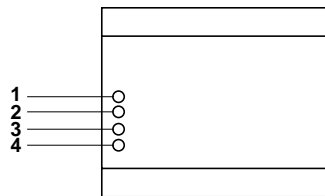

- 1 A1-A2 supply voltage, internal electronic fuse status
- 2 Input S12 (A)
- 3 Input S22 (B)
- 4 K1/K2 status (N.O. safety outputs closed)

XPSAM Functional Diagrams

Emergency Stop Function

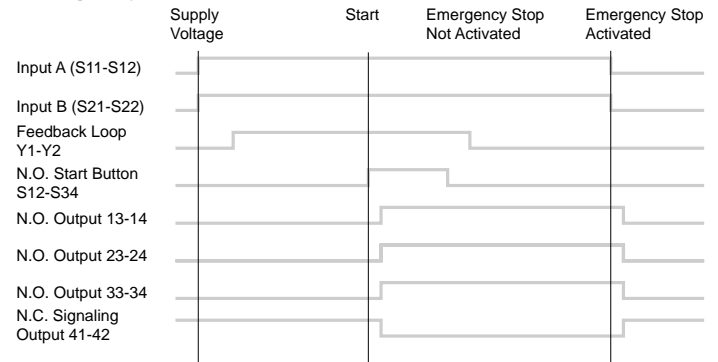

Legend 0 1

Limit Switch Monitoring with Automatic Start

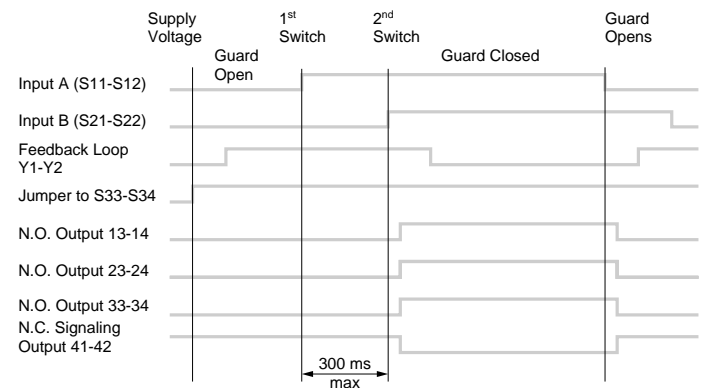

Legend 0 1

PREVENTA™ XPS Safety Relays Emergency Stop and Limit Switch Monitoring

Wiring Diagrams and Connections

XPSAP

XPSAP module with a 2-N.C.-contact emergency stop button

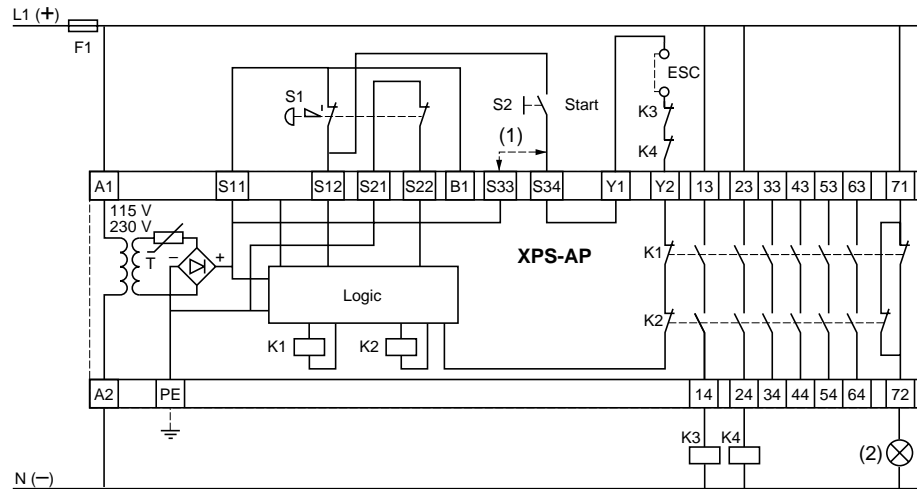

ESC: External Start Conditions
Y1-Y2: Feedback loop
(1) Wiring for automatic start (S33-S34)
(2) Signalling output (71-72) (not a safety output)

LED Signals

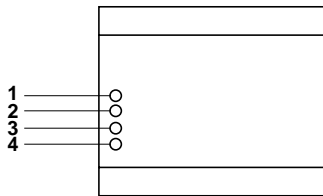

- 1 A1-A2 supply voltage, internal electronic fuse status
- 2 S12 Input (A)
- 3 S22 Input (B)
- 4 K1/K2 status (N.O. safety outputs closed)

XPSAP Functional Diagrams

Emergency Stop Function

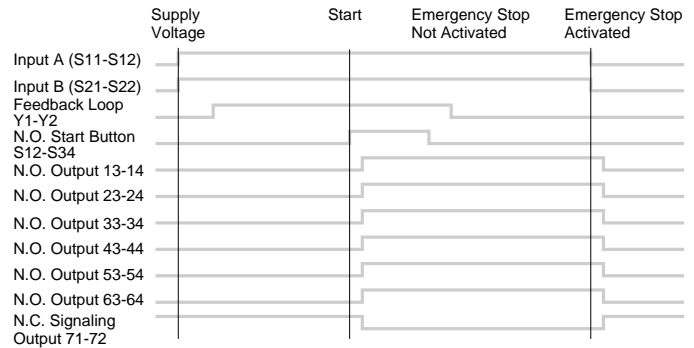

Legend 0 — 1

Limit Switch Monitoring with Automatic Start

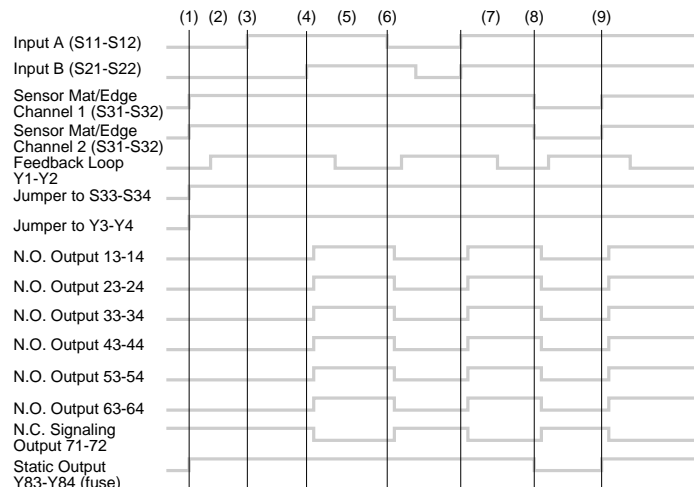

PREVENTA™ XPS Safety Relays

Emergency Stop and Limit Switch Monitoring

Wiring Diagrams and Connections

XPSAS/AM/AP

Configuration Emergency Stop Monitoring

1-Channel Wiring

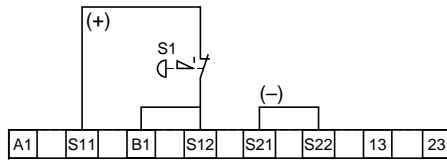

XPS-AS/AM/AP
Emergency Stop Button with 1 N.C. Contact
Not all errors are detected: A short-circuit on the emergency stop button is not detected.

2-Channel Wiring

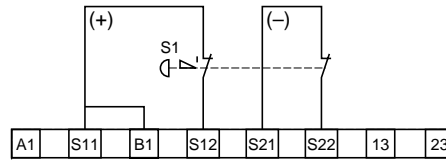

XPS-AS/AM/AP
Emergency stop button with 2 N.C. contacts (recommended application).
The 2 input channels are supplied different voltages. A short-circuit between the two inputs is detected.

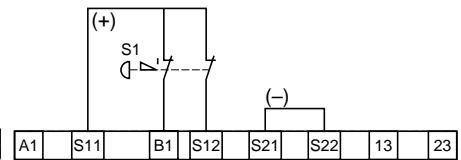

XPS-AS/AM/AP
Emergency stop button with 2 N.C. contacts.
Both input channels are supplied the same voltage. A short-circuit between the inputs is not detected.

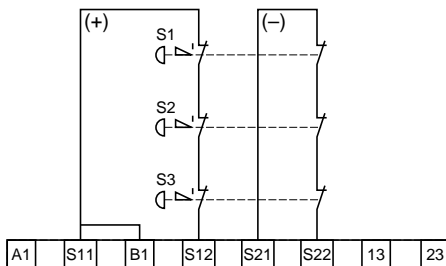

XPS-AS/AM/AP
Connection to multiple emergency stop buttons with 2 N.C. contacts (recommended application).
The 2 input channels are supplied different voltages. A short-circuit between the inputs is detected.

Monitoring of a guard associated with a 2-N.C.-contact limit switch

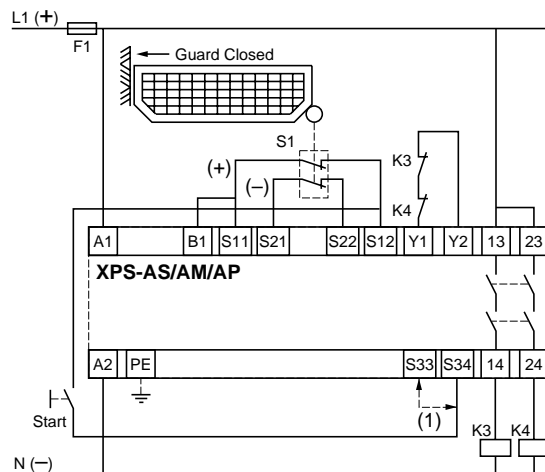

Single limit switch lock for a movable guard with manual or automatic reset after closing.
In automatic reset mode (1), synchronization time between the 2 inputs is monitored. In manual reset mode using start button between S12-S34, input synchronization time is unlimited.

Monitoring of a movable guard associated with 2 limit switches with 1 contact each (limit switch 1 (S1) with N.O. contact; limit switch 2 (S2) with N.C. contacts).

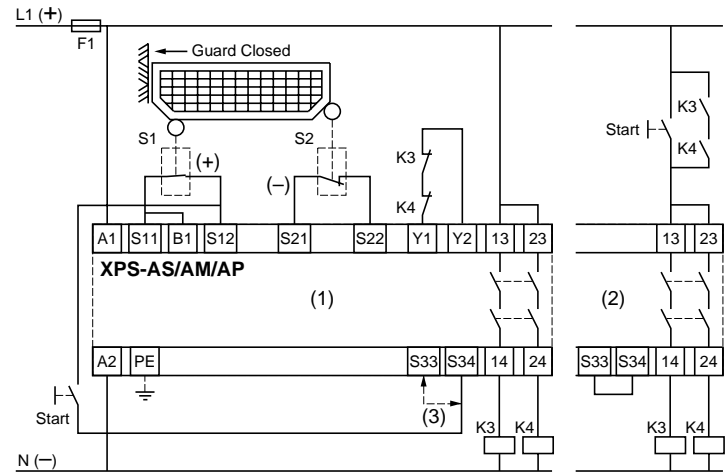

(1) Manual reset after closing, no synchronization control of limit switches, using the start button between S12-S34 and without the jumper between S33-S34.
(2) Manual reset after closing, with limit switch synchronization control.
(3) Automatic reset after closing with limit switch synchronization control, with the jumper between S33-S34.

To achieve category 3 or 4 when using safety interlocks or limit switches, they must be **both** mechanical and electrical redundancy, requiring 2 separate devices. Therefore, using **only** one safety interlock or **only** one limit switch will meet **only** category B, 1 or 2.

PREVENTA™ XPS Safety Relays

Emergency Stop, Limit Switch, Sensor Mat and Edge Monitoring

Technical Data

Module Type		XPSASF	XPSAMF	XPSAPF
Power Supply				
Voltage	V	24/48 Vac/dc, 115/230 Vac		
Voltage limits		- 20...+10 % Vac, +20 % (24/48 Vdc) - 15...+15 % (115 Vac) - 15...+10 % (230 Vac)		
Frequency	Hz	50/60		
Power Consumption				
24 V	VA	< 4		< 7
48 V		< 4		< 7
115 V/230 V		< 6		< 10
Module Fuse Protection		≤ 4 A external fuse for 24 V and 48 V versions, internal electronic for 115 V and 230 V versions		
Control Unit Voltage Between S11-S12, S21-S22 or S11-B1	V	24 Vdc (24 V version), 48 Vdc (48 V, 115 V, 230 V versions)		
Minimum Voltage and Current between terminals S11-S12, S21-S22 or S11-B1 (inputs A and B)				
U min/I min - 24 V (20 °C) version		16 V/70 mA	16 V/60 mA	16 V/100 mA
U min/I min - 48 V (20 °C) version		35 V/35 mA	35 V/25 mA	35 V/45 mA
U min/I min - 115 V/230 V (20 °C) version		41 V/35 mA	41 V/25 mA	41 V/45 mA
Calculation of the Wiring Resistance RL between terminals S11-S12, S21-S22 or S11-B1 as a function of internal supply voltage U int (terminals S11-S21)	Ω	$RL_{max} = \frac{U_{int} - U_{min}}{I_{min}}$ Ue = true voltage applied to terminals A1-A2 U int = supply voltage Ue - 3 V (24 V, 48 V version) U int between 42 V and 45 V, with typical value = 45 V (115 V, 230 V version) RL max must not exceed 50 Ω		
Max. Sensor Mat and Edge Resistance between terminals S31-S32, S41-S42	Ω	50		
Synchronization Time Between Inputs A and B automatic start, jumpered terminals S33-S34 and Y3-Y4	ms	Approximately 300		
Outputs		Relay hard contacts		
Voltage reference		Relay hard contacts		
No. and nature of safety circuits		2 N.O. (13-14, 23-24)	3 N.O. (13-14, 23-24, 33-34)	6 N.O. (13-14, 23-24, 33-34, 43-44, 53-54, 63-64)
No. and nature of additional circuits		2 static	1 N.C. (41-42) + 2 static	1 N.C. (71-72) + 2 static
AC-15 Breaking capacity	VA	C300: inrush 1800, sealed 180	B300: inrush 3600, sealed 360	
DC-13 Breaking capacity		24 V/1.5 A - L/R = 50 ms		
Breaking cap. of static outputs		24 V/20 mA, 48 V/10 mA		
Max thermal current (Ithe)	A	5	6	
Output fuse protection	A	4 A fuse; per IEC 947-5-1, DIN VDE Part 200	6 A fuse; per IEC 947-5-1, DIN VDE Part 200	
Minimum current	mA	10		
Minimum voltage	V	17		
Electrical Life		See page 78		
Response Time upon Input Opening	ms	< 40		
Rated Insulation Voltage	V	300 (Pollution degree 2 per IEC 947-5-1, DIN VDE 0110 Parts 1 and 2)		
Rated Impulse Withstand Voltage (Uimp)	kV	4 (Overvoltage category III, per IEC 947-1, DIN VDE 0110 Parts 1 and 2)		
LED Display		4		
Operating Temperature		+ 14 °F to + 130 °F (- 10 °C to + 55 °C)		
Storage Temperature		- 13 °F to + 185 °F (- 25 °C to + 85 °C)		
Degree of Protection per IEC 529				
Terminals		IP 20		
Housing		IP 40		
Connection				
Type		Captive screw-clamp terminals. Maximum wire size: 1-12 AWG (1 x 4 mm ²) without cable end, 2-14 AWG (2 x 2.5 mm ²) with cable end		

PREVENTA™ XPS Safety Relays

Emergency Stop, Limit Switch, Sensor Mat and Edge Monitoring



XPSASF

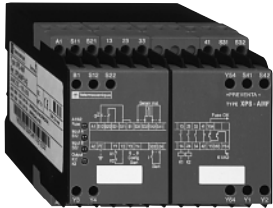

XPSAMF

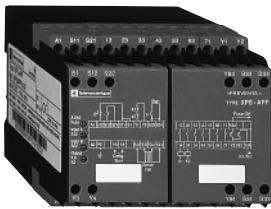

XPSAPF

Ordering Information

Description	No. of Safety Circuits	Static Outputs to PLC	Power Supply	Catalog Number	Weight oz. (kg)
Safety modules for monitoring emergency stops, limit switches sensor mats and edges	2	2	24 Vac/dc	XPSASF5142	12 (0.350)
			48 Vac/dc	XPSASF5342	12 (0.350)
			115 Vac	XPSASF3442	16 (0.450)
			230 Vac	XPSASF3742	16 (0.450)
	3	2	24 Vac/dc	XPSAMF5142	21 (0.600)
			48 Vac/dc	XPSAMF5342	21 (0.600)
			115 Vac	XPSAMF3442	25 (0.700)
			230 Vac	XPSAMF3742	25 (0.700)
	6	2	24 Vac/dc	XPSAPF5142	21 (0.600)
			48 Vac/dc	XPSAPF5342	21 (0.600)
			115 Vac	XPSAPF3442	25 (0.700)
			230 Vac	XPSAPF3742	25 (0.700)

Suitable for use in circuits through Category 4 per EN954-1.



File E164353
CCN NKCR



File LR44087
Class 3211 03



Dimensions 147-148

PREVENTA™ XPS Safety Relays

Emergency Stop, Limit Switch, Sensor Mat and Edge Monitoring

WIRING DIAGRAMS AND CONNECTIONS

XPSASF Module with a 2-N.C. Contact Emergency Stop Button

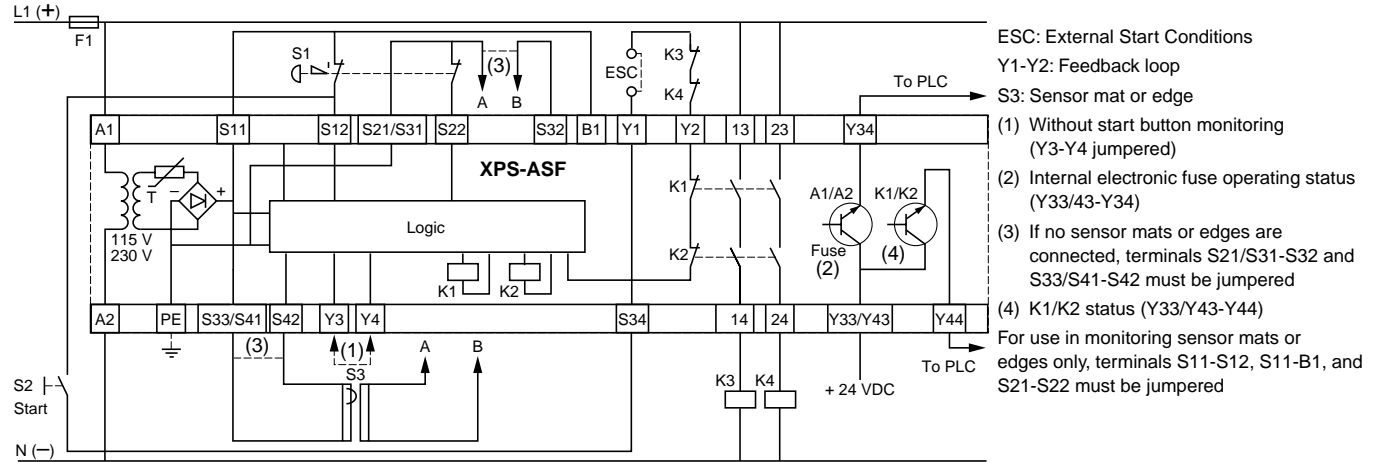

XPSASF Functional Diagram – Emergency Stop Function

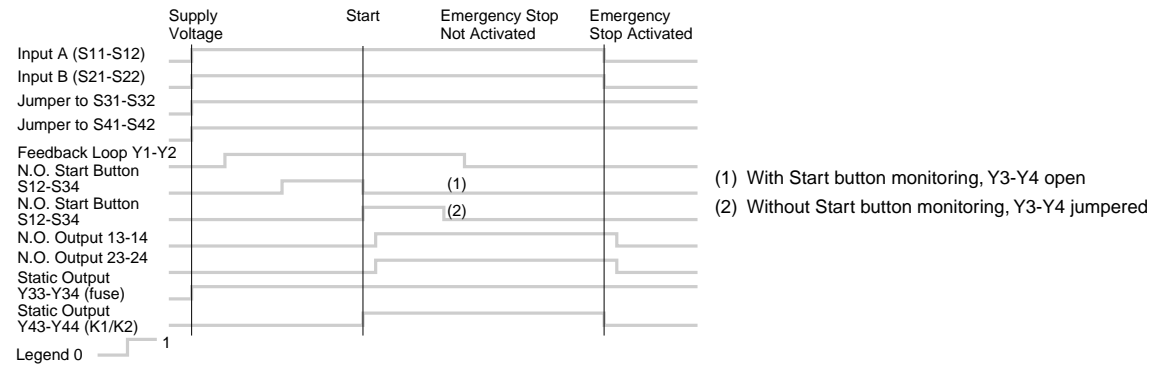

XPSASF Module Connected to Multiple Emergency Stop Buttons and PLC (The PLC outputs are controlled by the XPSASF module.)

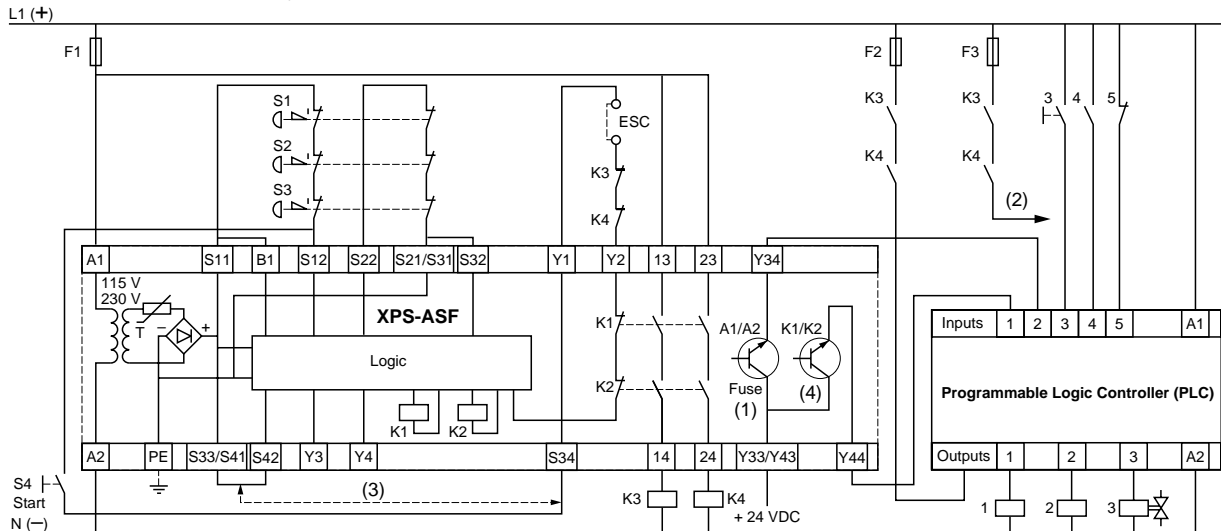

- ESC: External Start Conditions Y1-Y2: Feedback loop
- (1) Internal electronic fuse operating status (Y33/Y43-Y34)
 - (2) Additional circuits controlled by the safety relay through the external relays or contactors
 - (3) Wiring for automatic start (S33/S41-S34). Must be configured without start button monitoring (Y3-Y4 jumpered). If configured for start button monitoring (Y3-Y4 not jumpered) the N.O. safety contacts will not close.
 - (4) K1/K2 status (Y33/Y43-Y44)
- Since no sensor mats or edges are connected, terminals S21/S31-S32 and S33/S41-S42 must be jumpered
- The output portion of the PLC is controlled by the safety relay

PREVENTA™ XPS Safety Relays

Emergency Stop, Limit Switch, Sensor Mat and Edge Monitoring

Wiring Diagrams and Connections

XPSASF – Example of a safety circuit connecting the XPSASF module to limit switches and/or sensor mat and PLC

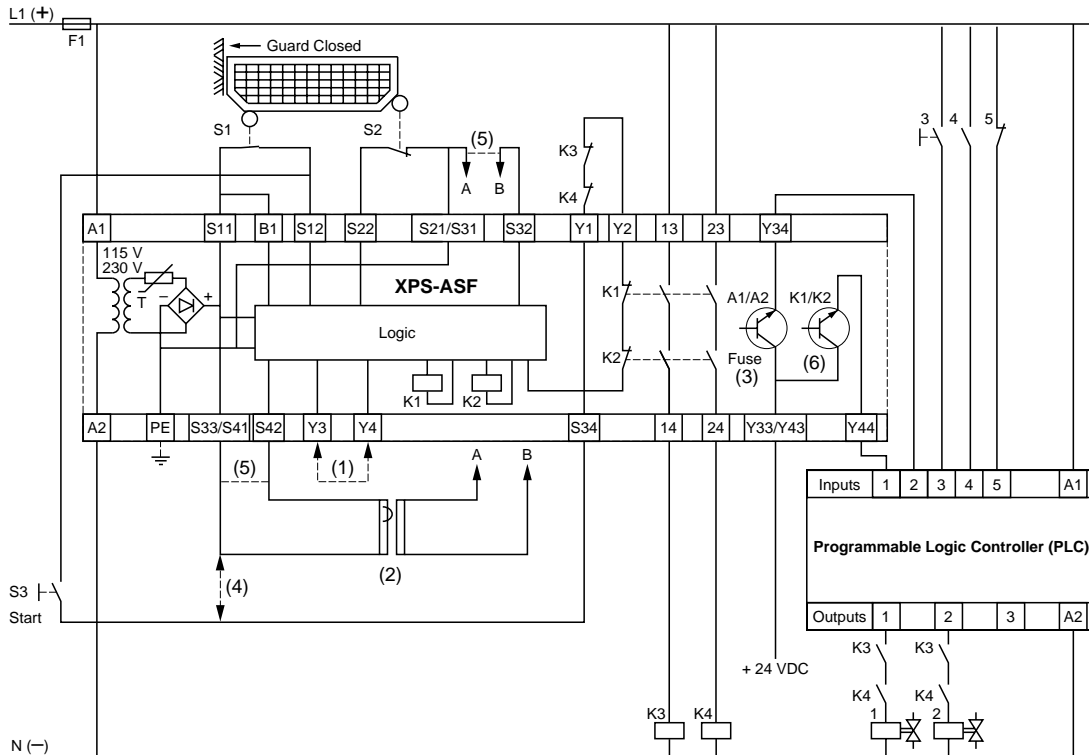

- (1) Without start button monitoring (Y3-Y4 jumpered)
- (2) Sensor mat or edge
- (3) Internal electronic fuse operating status (Y33/Y43-Y34)
- (4) Wiring for automatic start (S33/S41-S34). Must be configured without start button monitoring (Y3-Y4 not jumpered) the N.O. safety contacts will not close.
- (5) If no sensor mats or edges are connected, terminals S21/S31-S32 and S33/S41-S42 must be jumpered
- (6) K1/K2 status (Y33/Y43-Y44)

XPSASF Functional Diagram

With sensor mats or edges and with limit switches
Configured for automatic start

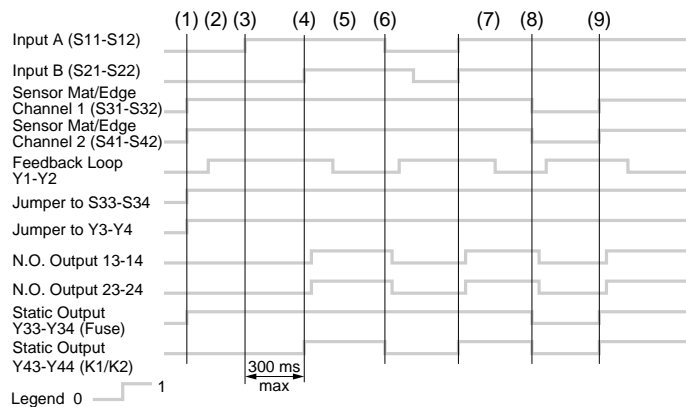

- (1) Supply voltage
- (2) Guard open
- (3) 1st switch
- (4) 2nd switch
- (5) Guard closed
- (6) Guard opens
- (7) Guard closes
- (8) Walk on mat
- (9) Deactivate mat

XPSASF Functional Diagram

With sensor mats or edges, without limit switches
Configured with start button

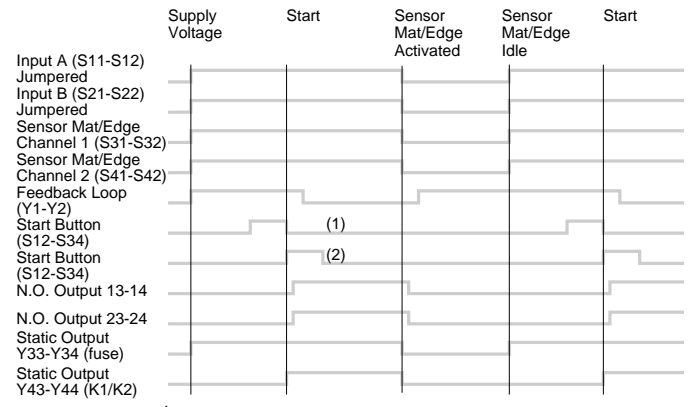

- (1) With Start button monitoring (Y3-Y4 open)
- (2) Without Start button monitoring (Y3-Y4 jumpered)

PREVENTA™ XPS Safety Relays

Emergency Stop, Limit Switch, Sensor Mat and Edge Monitoring

Wiring Diagrams and Connections

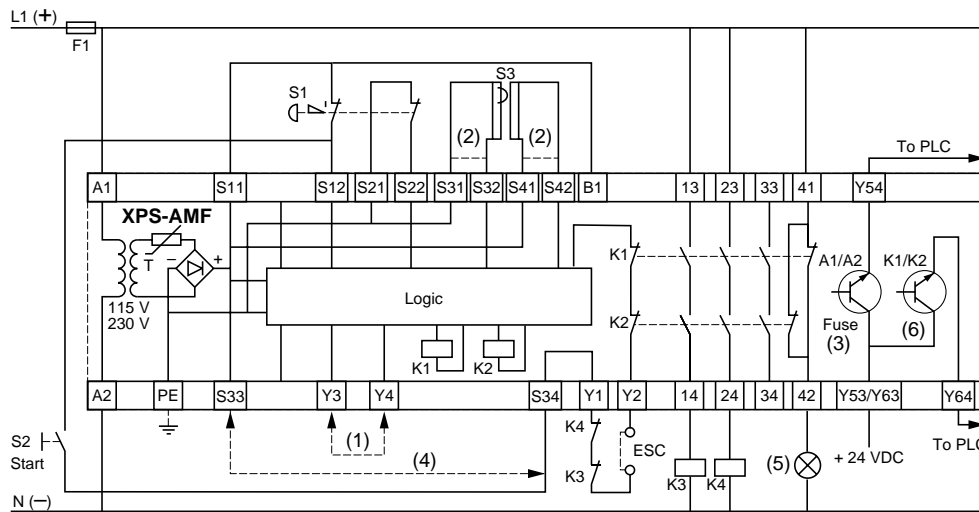

- ESC: External Start Conditions
 Y1-Y2: Feedback loop
 S3: Sensor mat or edge
- (1) Without start button monitoring (Y3-Y4 jumpered)
 - (2) If no sensor mats or edges are connected, terminals S31-S32 and S41-S42 must be jumpered
 - (3) Internal electronic fuse operating status (Y53/Y63-Y54)
 - (4) Wiring for automatic start (S33-S34). Must be configured without start button monitoring (Y3-Y4 jumpered). If configured for start button monitoring (Y3-Y4 not jumpered) the N.O. safety contacts will not close.
 - (5) Signalling output (41-42) (not a safety output)
 - (6) K1/K2 status (Y53/63-Y64).
- For use in monitoring sensor mats or edges only, terminals S11-S12, S11-B1 and S21-S22 must be jumpered.

XPSAMF Functional Diagram – Emergency Stop Function

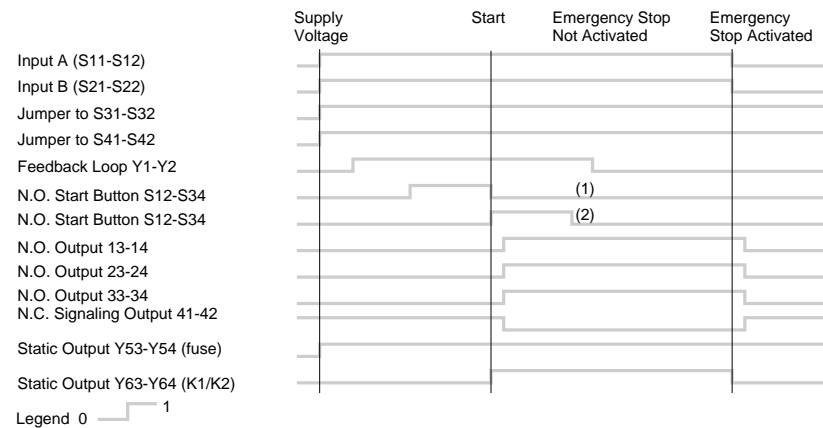

(1) With Start button monitoring (Y3-Y4 open). (2) Without Start button monitoring (Y3-Y4 jumpered).

LED Signals

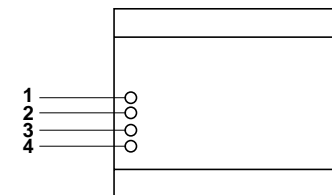

- 1 A1-A2 supply voltage, internal electronic fuse status. Sensor mat/edge not activated
- 2 S12 input status (A)
- 3 S22 input status (B)
- 4 K1/K2 Status (N.O. safety outputs closed)

XPSAMF Functional Diagram – Sensor Mat or Edge Function

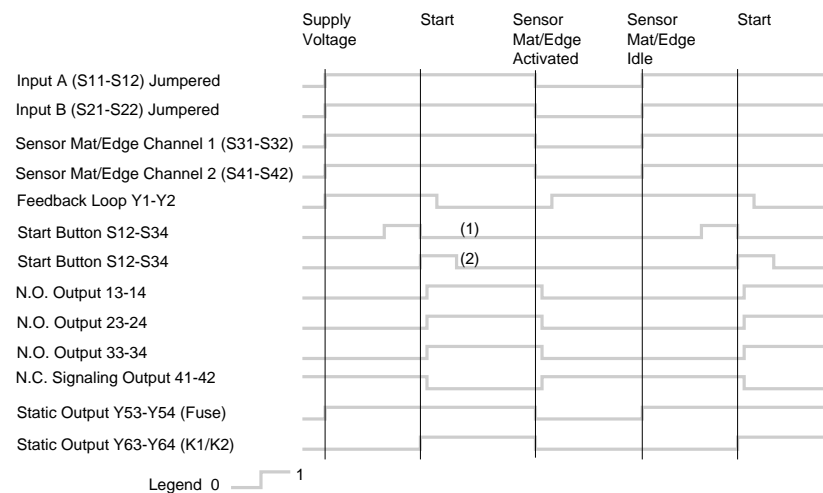

(1) With Start button monitoring (Y3-Y4 open). (2) Without Start button monitoring (Y3-Y4 jumpered).

PREVENTA™ XPS Safety Relays

Emergency Stop, Limit Switch, Sensor Mat and Edge Monitoring

Wiring Diagrams and Connections

XPS-APF

XPS-APF Module for Emergency Stop and Sensor Mat Monitoring

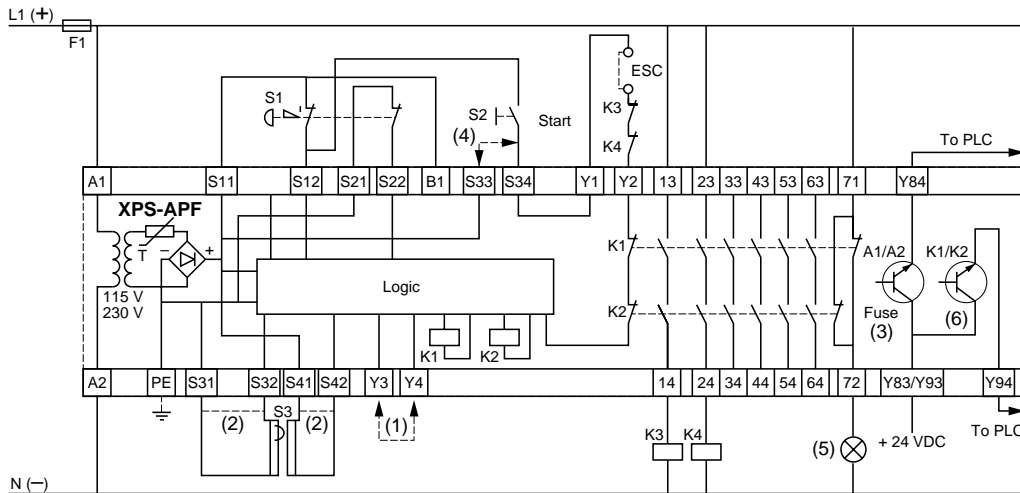

ESC: External Start Conditions

Y1-Y2: Feedback loop

S3: Sensor mat or edge

- (1) Without start button monitoring (Y3-Y4 jumpered)
- (2) If no sensor mats or edges are connected, terminals S31-S32 and S41-S42 must be jumpered
- (3) Internal electronic fuse operating status (Y83/Y93-Y84)
- (4) Wiring for automatic start (S33-S34). Must be configured without start button monitoring (Y3-Y4 jumpered). If configured for start button monitoring (Y3-Y4 not jumpered) the N.O. safety contacts will not close.
- (5) Signalling output (71-72) (not a safety output)
- (6) K1/K2 status (Y83/93-Y94)

For use in monitoring sensor mats or edges only, terminals S11-S12, S11-B1 and S21-S22 must be jumpered

XPS-APF Functional Diagrams

Emergency Stop Function

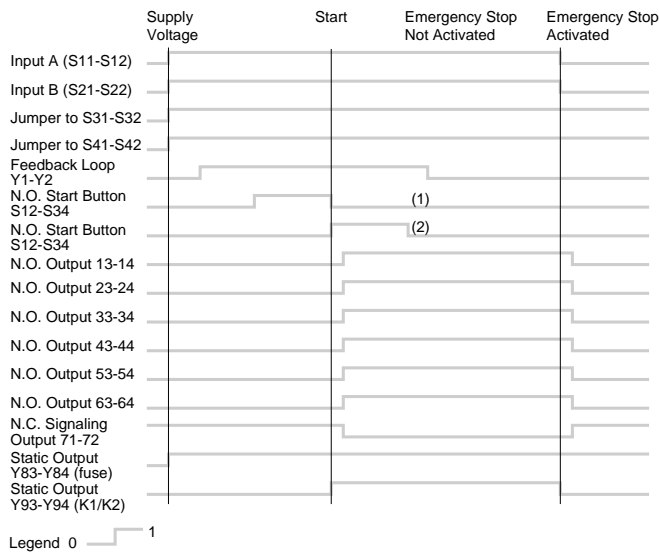

- (1) With start button monitoring, Y3-Y4 open.
- (2) Without start button monitoring, Y3-Y4 jumpered.

With Automatic Start and Sensor Mat

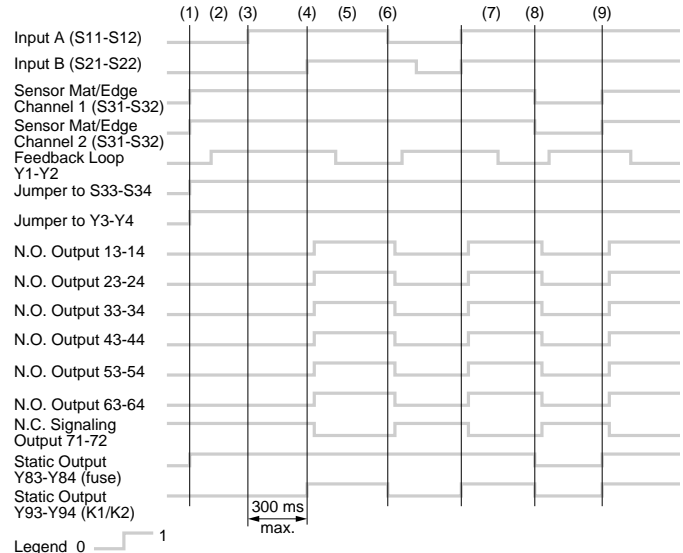

- (1) Supply voltage
- (2) Guard open
- (3) 1st switch
- (4) 2nd switch
- (5) Guard closed
- (6) Guard opens
- (7) Guard closes
- (8) Walk on mat
- (9) Deactivate mat

LED Signals

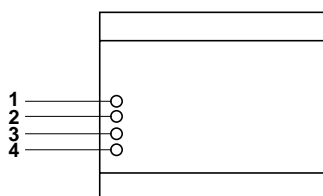

- 1 A1-A2 supply voltage, internal electronic fuse status. Sensor mat or edge deactivated.
- 2 S12 Input status (A)
- 3 S22 Input status (B)
- 4 K1/K2 Status (N.O. safety outputs closed)

PREVENTA™ XPS Safety Relays Emergency Stop, Limit Switch, Sensor Mat and Edge Monitoring

Wiring Diagrams and Connections for XPSASF/AMF/APF

Configuration for Emergency Stop Monitoring

Single-Channel Wiring

Emergency stop button with single N.C. contact.
Not all faults are detected: a short-circuit on the emergency stop push button is not detected.

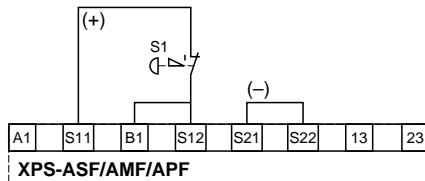

2-Channel Wiring – Different Voltage

Emergency stop button with 2 N.C. contacts (recommended application).

The two input channels are supplied different voltages. A short-circuit between the 2 inputs is detected.

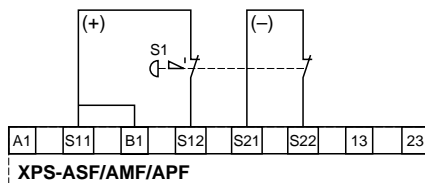

2-Channel Wiring – Same Voltage

Emergency stop button with 2 N.C. contacts.

Both input channels are supplied the same voltage. A short-circuit between the 2 inputs is not detected.

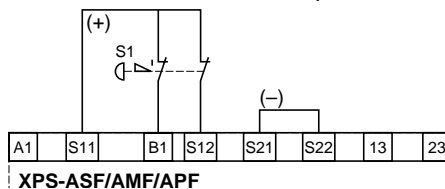

Multiple Emergency Stop Buttons

Connection of several emergency stop buttons with 2 N.C. contacts (recommended application).

The two input channels are supplied different voltages. A short-circuit between the 2 inputs is detected.

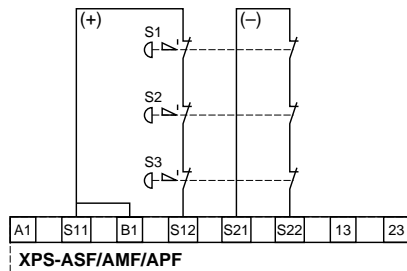

Configuration with Automatic and Manual Reset

Automatic start

Both S33-S34 and Y3-Y4 must be jumpered.

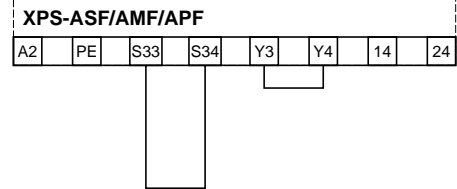

Without Start button monitoring,
manual reset

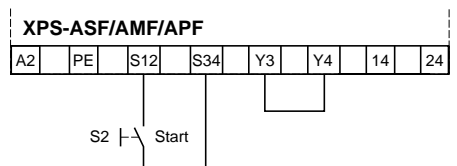

With Start button monitoring,

manual reset, start button must be pushed *and* released.

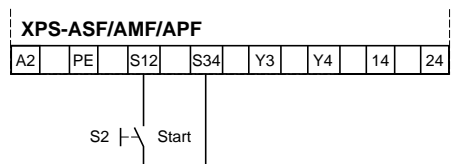

PREVENTA™ XPS Safety Relays

Safety Contact Expansion

Operating Principle

XPSEC safety contact expansion modules are available as attachments for PREVENTA XPS basic modules (for emergency stop, limit switch, two-hand control functions).

They are used to increase the number of basic module safety output contacts.

Technical Data

Module Type		XPSECM	XPSECP
Power Supply			
Voltage	V	24 Vac/dc, 115/230 Vac	
Voltage limits		- 20...+10 % (24 Vac), + 20 % (24 Vdc) - 15...+15 % (115 Vac) - 15...+10 % (230 Vac)	
Frequency	Hz	50/60	
Power Consumption			
24 V	VA	< 5	
115 V/230 V	VA	< 6	
Module Fuse Protection		≤ 4 A external fuse for 24 V versions, internal electronic for 115 V and 230 V versions	
Outputs			
Voltage reference		Relay hard contacts	
No. and nature of safety circuits		4 N.O. (13-14, 23-24, 33-34, 43-44)	8 N.O. (13-14, 23-24, 33-34, 43-44, 53-54, 63-64, 73-74, 83-84)
No. and nature of additional circuits		1 N.C. (41-42) + 1 static	1 N.C. (91-92) + 1 static
AC-15 Breaking capacity	VA	B300: inrush 3600, sealed 360	
DC-13 Breaking capacity		24 V/1.5 A - L/R = 50 ms	
Static output breaking capacity		24 V/20 mA, 48 V/10 mA	
Max thermal current (I _{the})	A	5	
Maximum thermal current sum	A	24	30
Output fuse protection per IEC 947-5-1, VDE 0660 Part 200	A	6 A fuse	
Minimum current	mA	10	
Minimum voltage	V	17	
Electrical Life		See page 78	
Response Time from Input Breaking	ms	< 20	
Rated Insulation Voltage (U_i)	V	300 (Pollution degree 2 per IEC 947-5-1, DIN VDE 0110 Parts 1 and 2)	
Rated Impulse Withstand Voltage (U_{imp})	kV	4 (Overvoltage category III, per IEC 947-1, DIN VDE 0110 Parts 1 and 2)	
LED Display		3	
Operating Temperature		+ 14 °F to + 130 °F (- 10 °C to + 55 °C)	
Storage Temperature		- 13 °F to + 185 °F (- 25 °C to + 85 °C)	
Degree of Protection per IEC 529			
Terminals		IP 20	
Housing		IP 40	
Connection			
Type		Captive screw-clamp terminals. Maximum wire size: 1-12 AWG (1 x 4 mm ²) without cable end, 2-14 AWG (2 x 2.5 mm ²) with cable end	

PREVENTA™ XPS Safety Relays Safety Contact Expansion

Ordering Information

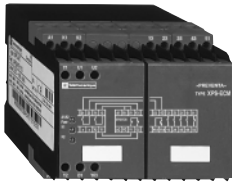

XPSECM

Description	No. of Safety Circuits	Power Supply	Catalog Number	Weight oz. (kg)
Safety modules for expanding the number of safety contacts	4	24 Vac/dc	XPSECM5131	19 (0.550)
		115 Vac	XPSECM3431	23 (0.650)
		230 Vac	XPSECM3731	23 (0.650)
	8	24 Vac/dc	XPSECP5131	19 (0.550)
		115 Vac	XPSECP3431	23 (0.650)
		230 Vac	XPSECP3731	23 (0.650)

Suitable for use in circuits through Category 4 per EN954-1.

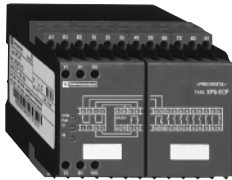

XPSECP



File E164353
CCN NKCR



File LR44087
Class 3211 03



Dimensions147-148

PREVENTA™ XPS Safety Relays

Safety Contact Expansion

Wiring Diagrams and Connections

XPSECM Connection Diagram

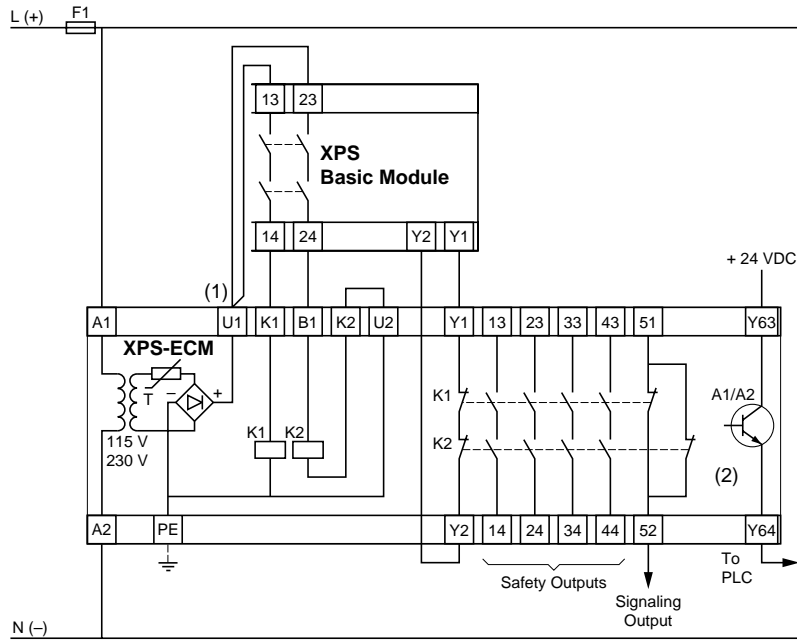

- (1) When installing basic modules and contact expansion modules into different electrical enclosures, use different individual wires between terminals U1-13 and U1-23.
- (2) Operating status of internal electronic fuse (Y63-Y64).

Functional Diagram of the XPSECM Module

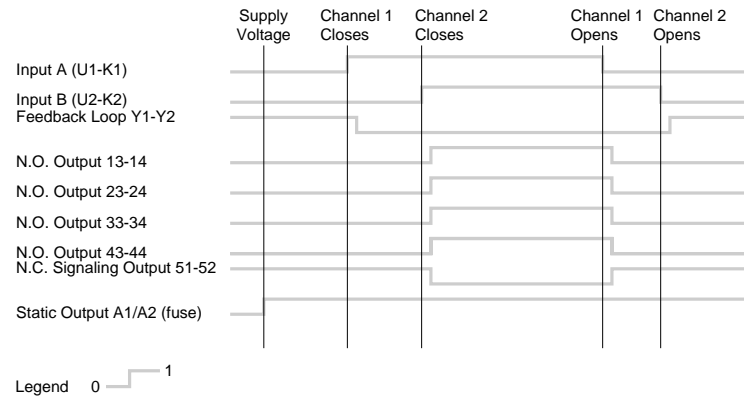

Wiring Diagrams and Connections

**XPSECP
Connection Diagram**

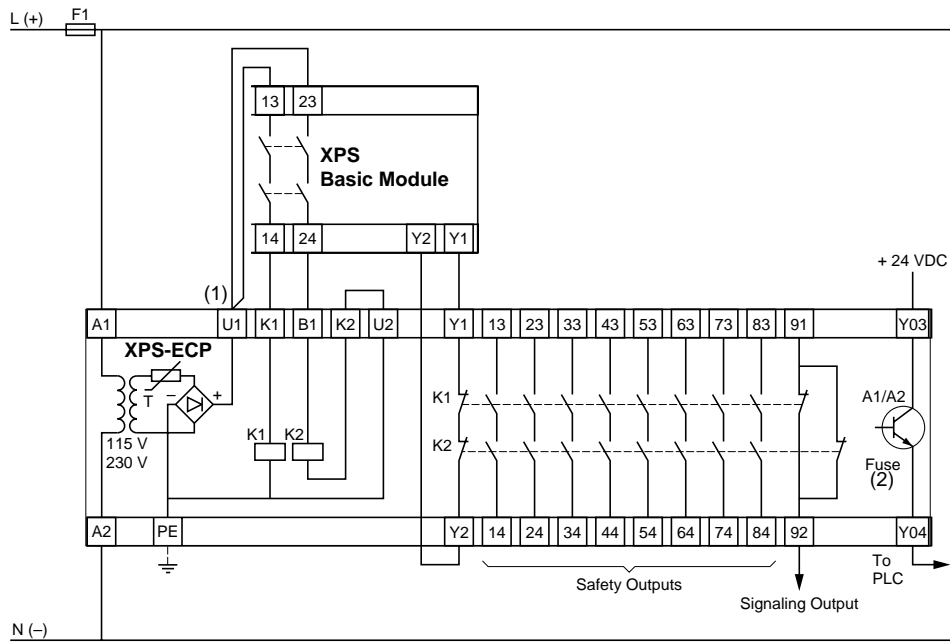

- (1) When installing basic modules and contact expansion modules into different electrical enclosures, use different individual wires between terminals U1-13 and U1-23.
- (2) Operating status of internal electronic fuse (Y03-Y04).

Functional Diagram of the XPSECP Module

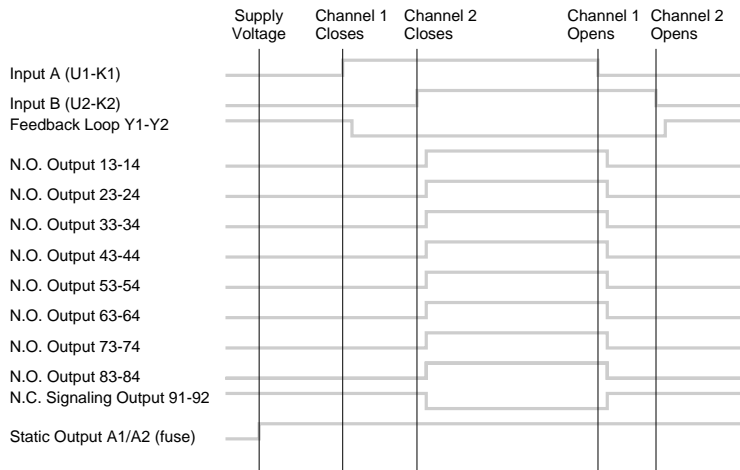

Legend 0 1

PREVENTA™ XPS Safety Relays Limit Switch Monitoring

Operating Principle

The PREVENTA XPSFB limit switch monitoring module meets the requirements for operational monitoring of 2 limit switches that monitor personnel protection equipment (e.g.: gates, guards, access covers, doors, etc.). It can also be configured to monitor two relay-output photoelectric sensors (e.g., for access to robot areas). For this configuration, each sensor must be equipped with a N.O. and N.C. contact or a N.O./N.C. contact. These cannot be make-before-break contacts.

The XPSFB module monitors the operation of the limit switches connected to it during protection equipment installation. It automatically detects operation or limit switch wiring faults. Fault detection (shorting or change in the state of the currently operating contact) causes the safety contacts of the module to open immediately, thereby stopping the hazardous motion of the machinery monitored.

After the module is energized, it is necessary to open the protection equipment, verify the limit switch connections, and reclose the protection equipment. This verification can be simulated using the reset button. When the feedback loop is closed, the module safety circuits are activated once the protective guard is closed and the start button pressed (optional).

The feedback loop allows self-testing of relays or contactors with mechanically-linked contacts designed to increase the number of output contacts or the current switching capacity.

The XPSFB start button function is determined by the location of a jumper supplied by the user. If terminals Y3-Y5 are connected, the start button is integrated into monitoring, and the safety outputs are activated on the trailing edge of the output signal when the start button is released. If terminals Y3-Y4 are connected, the safety outputs are activated immediately when the start button is pushed. When the start button is jumpered, this configuration allows automatic module operation upon closing of the protection equipment.

PREVENTA™ XPS Safety Relays Limit Switch Monitoring

Technical Data

Module Type		XPSFB
Power Supply		
Voltage	V	24/48 Vac/dc, 115/230 Vac
Voltage limits		- 20...+10 % (24/48 Vac); +20 % Vdc - 15...+15 % (115 Vac) - 15...+10 % (230 Vac)
Frequency	Hz	50/60
Power Consumption	VA	< 8
Module Fuse Protection		≤ 4 A external fuse for 24 V and 48 V versions, internal electronic for 115 V and 230 V versions
Inputs		S1: N.O. + N.C., S2 N.O. + N.C.
Synchronization Time	s	Approximately 1.5
Start Button Monitoring		Yes (user configurable by terminal connections)
Control Unit Voltage between S12/S13-S11, S22/S23-S21		
24 V Version	V	24 Vdc
48 V/115 V/230 V Version	V	48 Vdc
Minimum Voltage and Current between terminals S12/S13-S11, S22/S23-S21		
U min/I min - 24 V (20 °C) version		17.5 V/140 mA
U min/I min - 48 V (20 °C) version		35 V/40 mA
U min/I min - 115 V/230 V (20 °C) version		38 V/40 mA
Calculation of the Wiring Resistance RL between terminals S12/S13-S11, S22/S23-S21 as a function of the internal power supply voltage U int (terminals S12-S22)	Ω	$RL \max = \frac{U \text{ int} - U \text{ min}}{I \text{ min}}$ Ue = true voltage applied to terminals A1-A2 U int = power supply voltage Ue - 1.5 V (24 V, 48 V version) U int between 42 V and 45 V, with the typical value = 45 V (115 V, 230 V version) Maximum RL must not exceed 50 Ω
Outputs		
Voltage reference		Relay hard contacts
No. and nature of safety circuits		3 N.O. (13-14, 23-24, 33-34)
No. and nature of additional circuits		1 N.C. (41-42), 2 solid-state (Y53-Y54, Y63-Y64)
AC-15 Breaking capacity		C300: inrush 1800, sealed 180
DC-13 Breaking capacity		24 V/1.5 A - L/R = 50 ms
Breaking capacity of static outputs	mA	50 (48 V)
Max thermal current (Ithe)	A	2.5
Output fuse protection per IEC 947-5-1, VDE 0660 Part 200	A	4 A fuse
Minimum current	mA	10
Minimum voltage	V	17
Electrical Life		See page 78
Response Time	ms	< 20
Rated Insulation Voltage (Ui)	V	300 (pollution degree 2 per IEC 947-5-1, DIN VDE 0110 Parts 1 and 2)
Rated Impulse Withstand Voltage (Uimp)	kV	4 (Overvoltage category III, per IEC 947-1, DIN VDE 0110 Parts 1 and 2)
LED Display		3
Operating Temperature		+ 14 °F to + 130 °F (- 10 °C to + 55 °C)
Storage Temperature		- 13 °F to + 185 °F (- 25 °C to + 85 °C)
Degree of Protection per IEC 529		
Terminals		IP 20
Housing		IP 40
Connection		
Type		Captive screw-clamp terminals. Maximum wire size: 1-12 AWG (1 x 4 mm ²) without cable end, 2-14 AWG (2 x 2.5 mm ²) with cable end

PREVENTA™ XPS Safety Relays Limit Switch Monitoring

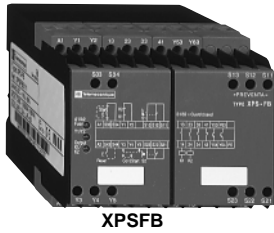

Ordering Information and Diagrams

Description	No. of Safety Circuits	Static Outputs for PLC Messaging	Power Supply	Catalog Number	Weight oz. (kg)
Safety Modules for Limit Switch Monitoring	3	2	24 Vac/dc	XPSFB5111	23 (0.650)
			48 Vac/dc	XPSFB5311	23 (0.650)
			115 Vac	XPSFB3411	30 (0.850)
			230 Vac	XPSFB3711	30 (0.850)

Suitable for use in circuits through Category 4 per EN954-1.

XPSFB Guard Locking on All Machines

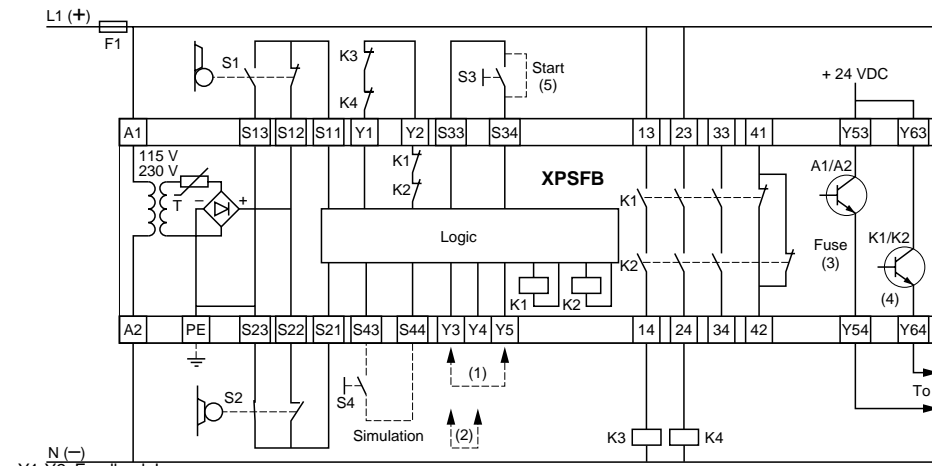

Y1-Y2: Feedback Loop
Output (41-42) must not be used as a safety circuit. It can be used for non-hazardous machinery movements.
S1, S2: Limit switches (guard closed)
S4: Simulation button (Simulates opening and closing of the movable guard)

LED Signals

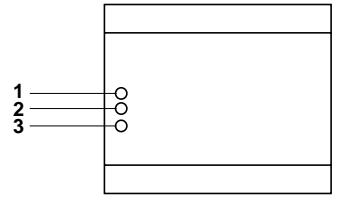

- 1 A1-A2 supply voltage, internal electronic fuse status
- 2 Y1-Y2 Feedback Loop + guard closed
- 3 K1-K2 status (N.O. safety outputs closed)

- (1) With start button monitoring
- (2) Without start button monitoring
- (3) Operating status of internal electronic fuse (Y53-Y54).
- (4) K1/K2 status (Y63-Y64).
- (5) Dashed line around S3 (N.O. start button between terminals S33-S34) indicates wiring for automatic start. This is only feasible when wired without start button monitoring. If S3 is jumpered and the module is configured for start button monitoring, the N.O. safety contacts will not close.

Functional Diagrams of the XPSFB Module

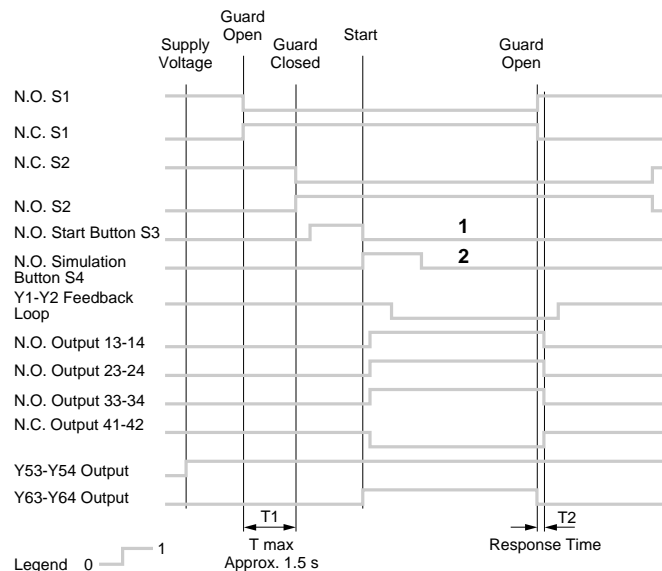

Legend 0 1
T max Approx. 1.5 s
Response Time
1 With Start button monitoring (Y3-Y5 jumpered)
2 Without Start button monitoring (Y3-Y4 jumpered)

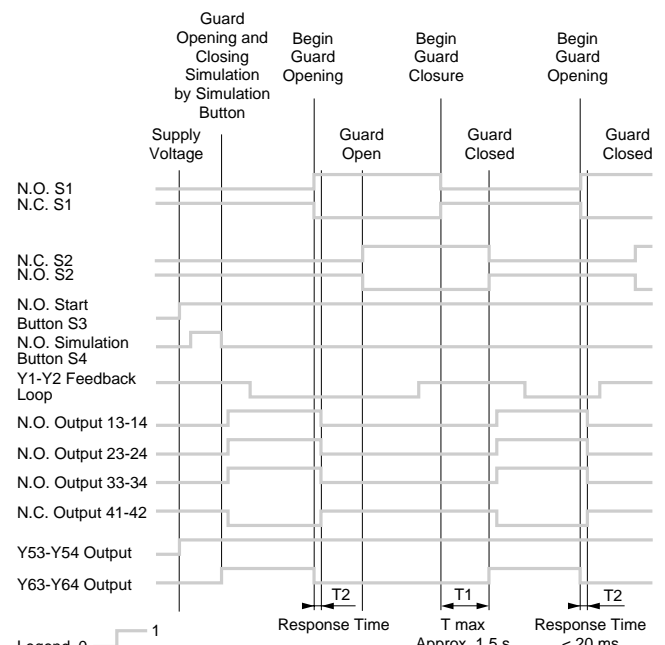

Legend 0 1
Response Time
T max Approx. 1.5 s
Response Time < 20 ms



File: E164353
CCN: NKCR

File: LR44087
Class: 3211 03

Wiring Diagrams and Connections

XPSFB

Guard Locking on an Injection Press per EN 201 standard

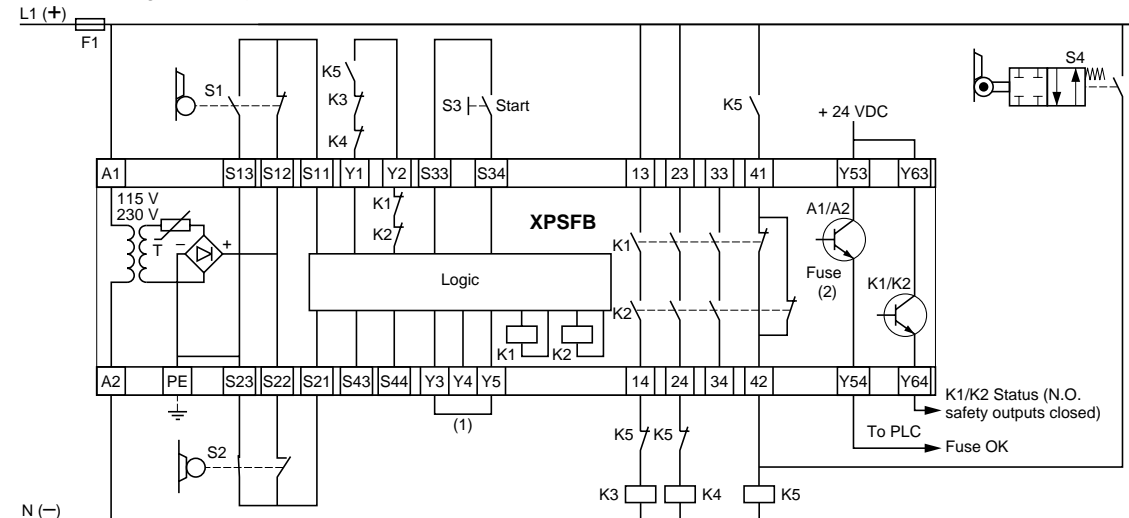

- S1-S2: Limit switches (guard closed position) S4: Hydraulic switch (guard closed position)
 (1) With Start button monitoring (2) Operating status of the internal electronic fuse

Monitoring Two Photoelectric Sensors with the XPSFB Module

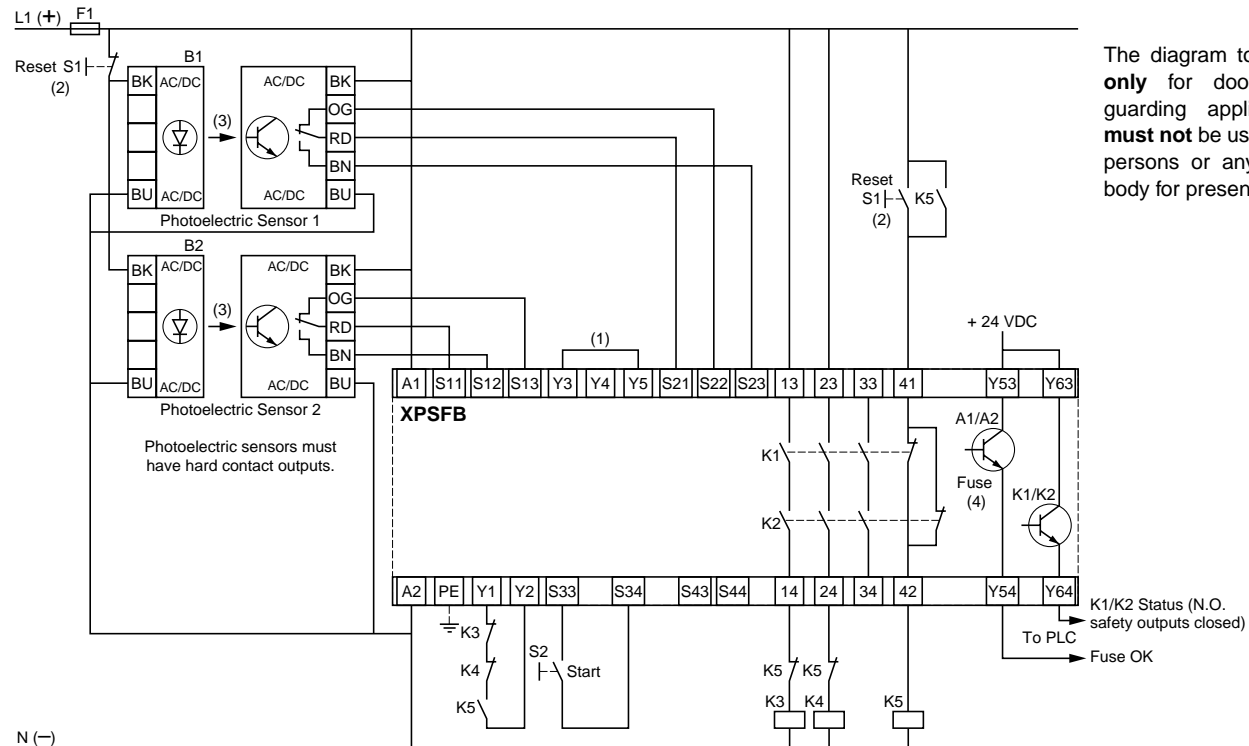

The diagram to the left is **only** for door or gate guarding applications. It **must not** be used to sense persons or any part of a body for presence sensing.

- (1) With Start button monitoring.
 (2) S1 Reset button: 1 N.O. contact + 1 N.C. contact.
 (3) To prevent interference between the 2 photoelectric sensors, bi-directional installation of these sensors is recommended (1 transmitter and 1 receiver on each side) to reverse the direction of the beams of photosensor 1 and 2.
 (4) Operating status of the internal electronic fuse.

PREVENTA™ XPS Safety Relays

Two-Hand Control Monitoring

Operating Principle

Two-hand control stations are designed to protect personnel from hand injuries. They require machine operators to keep their hands clear of the hazardous motion area. The use of two-hand control is an individual protective measure, which can protect only one operator. Separate two-hand control units must be provided for each operator in a multiple-worker environment. PREVENTA XPSBC two-hand control safety relays, described below, comply with the requirements of European standard EN 574 for two-hand control systems.

The control units must be designed and implemented such that they cannot be activated involuntarily or easily rendered inoperative. Depending on the specific application, they must meet the requirements of the Type C standards pertaining to machinery.

To initiate a hazardous motion, both control units (two-hand push buttons) must be activated within an interval of ≤ 0.5 s (synchronous activation). If only one of the two push buttons is pressed during a hazardous operation, the control sequence is cancelled. Continuation of the hazardous operation is possible only if both push buttons are returned to their initial position and reactivated within a pre-determined time period. The feedback loop provides self-testing for contactors or relays with mechanically linked contacts designed to increase the number of output contacts or the current switching capacity.

The control sequence does not occur if:

- Both two-hand control push buttons are pressed during a time period greater than 0.5 s,
- A short-circuit is present in a push button contact,
- The feedback loop is not closed at start-up.

There must be enough distance between the control units and the hazardous area so that when only one control unit is released, the hazardous area cannot be reached before the hazardous motion stops or the cycle is completed.

XPSBA

This module is designed for use on lighter duty applications where a two hand control function is desired, but where the safety category is B or 1 (per EN 954-1) and the two hand control requirements meet Type III A (per EN 574). **This module is not to be used for applications, such as presses, which require a Type III C module or where the application is not a category B or 1.** For press applications, for applications in category 2, 3, or 4, or if application calls for a Type III C module, use an XPSBC module.

XPSBC

This module can be used on applications, such as presses, which require a Type III C module. The XPSBC can be used for and two-hand control application, including presses and similar equipment.

PREVENTA™ XPS Safety Relays Two-Hand Control Monitoring

Technical Data

Module Type		XPSBA	XPSBC
Category, per EN 954-1		Category 1	Category 4
Two-Hand Control Type per EN 574		III-A	III-C
Power Supply			
Voltage	V	24 Vac/dc, 115/30 Vac	24 Vac/dc, 115/230 Vac
Voltage limits		- 20...+20 % (24 Vdc), - 20...+10 % (24 Vac), - 15...+ 5 % (115 Vac), -15...+10 % (230 Vac)	- 20...+10 % (24 Vdc), - 15...+10 % (24 Vac), - 15...+15 % (115 Vac), -15...+10 % (230 Vac)
Frequency	Hz	50/60	50/60
Power Consumption	VA	<17	< 6
Module Fuse Protection		internal electronic	
Inputs		S1: 1 N.C. + N.C., S2: 1 N.C. + N.C.	
Synchronization Time (maximum)	s	0.5	
Control Unit Voltage			
24 Vac Version	V	24	24
24 Vdc Version, 115 V, 230 V	V	24	48
Minimum voltage and current		between terminals T11-T12, T11-T13	between terminals T11-T13, T21-T23
U min/I min - 24 Vdc (20 °C) version		18 V / 30 mA	18 V / 140 mA
U min/I min - 24 V / 115 V / 230 Vac (20 °C) version		18 V / 30 mA	30 V / 50 mA
Calculation of wiring resistance RL between terminals T11-T13 and T21-T23 as a function of internal voltage supply U int (terminals T13-T23)	Ω		$RL_{max} = \frac{U_{int} - U_{min}}{I_{min}}$ Ue = True voltage applied to terminals A1-A2 U int = Supply voltage Ue - 1 V (24 V version) U int between 30.5 V and 35 V, with typical value = 35 V (115 V, 230 V version) Max RL must not exceed 50
Outputs		Relay Hard Contacts	Relay Hard Contacts
Voltage reference		Relay Hard Contacts	Relay Hard Contacts
No. and nature of safety circuits		1 N.O. (11-14)	2 N.O. (13-14, 23-24)
No. and nature of additional circuits		1 N.C. (11-12)	1 N.C. (31-32)
AC-15 Breaking capacity	VA	C300: inrush 1800, sealed 180	
DC-13 Breaking capacity		24 V/1.5 A - L/R = 50 ms	
Max thermal current (Ithe)	A	5	2.5
Output fuse protection per IEC 947-5-1, VDE 0660 Part 200 A	A	4 A fuse	
Minimum current	mA	10	
Minimum voltage	V	17	
Electrical Life		See page 78	
Response Time	ms	< 25	< 30
Rated Insulation Voltage (Ui)	V	300 (Pollution degree 2 per IEC 947-5-1, DIN VDE 0110 Parts 1 and 2)	
Rated Impulse Withstand Voltage (Uimp)	kV	4 (Overvoltage category III per IEC 947-1, DIN VDE 0110 Parts 1 and 2)	
LED Display		2	3
Operating Temperature		+ 14 °F to + 130 °F (- 10 °C to + 55 °C)	
Storage Temperature		- 13 °F to + 185 °F (- 25 °C to + 85 °C)	
Degree of protection per IEC 529			
Terminals		IP 20	
Housing		IP 40	
Connection		Captive screw-clamp terminals. Maximum wire size: 1-12 AWG (1 x 4 mm ²) without cable end, 2-14 AWG (2 x 2.5 mm ²) with cable end	
Type			

PREVENTA™ XPS Safety Relays

Two-Hand Control Monitoring

Selection

Standard EN 574 defines the selection of two-hand control stations as being dependent on the control system category.

The following table defines the three types of two-hand control stations, according to EN 574. For each type, it lists the operating stations and minimum requirements.

EN 574 Requirements	Type I	Type II	Type III		
			A	B	C
Use of both hands (simultaneous action)					
Link between input and output signals					
Output signal stop					
Prevention against accidental operation					
Tamper-proof					
Reinitialized output signal					
Synchronous action (time window)					
Use of proven components (Category 1)▲			XPSBA		
Redundancy with partial error detection (Category 3) ▲				XPSBC	
Redundancy + Self-testing (Category 4)▲					XPSBC

■ Meets the requirements of standard EN 574
 ▲ According to standard EN 954-1



XPSBA

Ordering Information

Description	Type per Standard EN 574	Power Supply	Catalog Number	Weight oz. (kg)
Safety modules for two-hand control station monitoring	III A	24 Vac/dc	XPSBA5120	7 (0.200)
		115 Vac	XPSBA3420	7 (0.200)
		230 Vac	XPSBA3720	7 (0.200)

Suitable for use in circuits through Category 1 per EN954-1.



XPSBC

Ordering Information

Description	Type per Standard EN 574	Power Supply	Catalog Number	Weight oz. (kg)
Safety modules for two-hand control station monitoring	III C	24 Vdc	XPSBC1110	14 (0.400)
		24 Vac	XPSBC3110	14 (0.400)
		115 Vac	XPSBC3410	14 (0.400)
		230 Vac	XPSBC3710	14 (0.400)

Suitable for use in circuits through Category 4 per EN954-1.

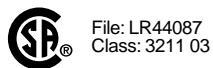

Dimensions 147-148

PREVENTA™ XPS Safety Relays Two-Hand Control Monitoring

XPSBA Wiring Diagram and Connections

XPSBA Module wired with a Two-Hand Control Station Type III A per EN 574

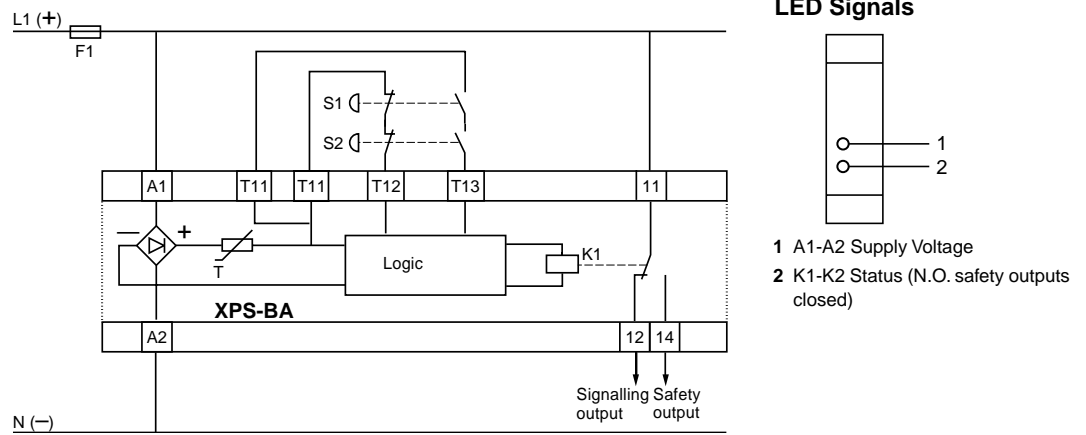

S1 and S2: push buttons

NOTE: Not to be used for applications, such as presses, which require a Type III C module. For press applications, or if application calls for a Type III C module, use an XPSBC module.

Functional Diagram of the XPSBA Module

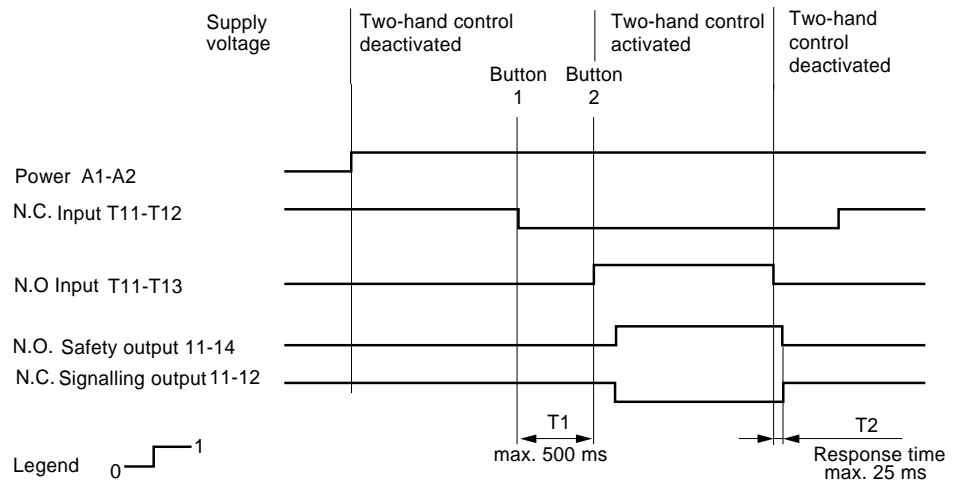

PREVENTA™ XPS Safety Relays

Two-Hand Control Monitoring

XPSBC Wiring Diagram and Connections

XPSBC Module wired with a Two-Hand Control Station Type III C per EN 574

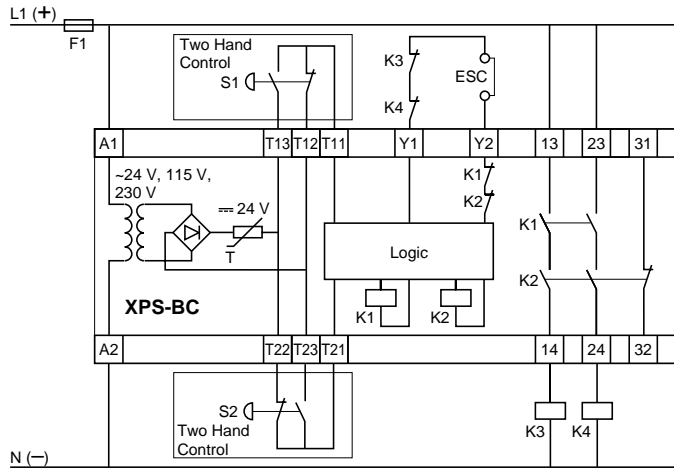

LED Signals

LED Signals

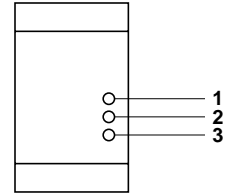

- 1 A1-A2, S1-S2 Supply Voltage
LED 1 indicates that buttons S1 and S2 are **properly connected**
- 2 Y1-Y2 Feedback Loop
- 3 K1-K2 Status (N.O. safety outputs closed)

ESC: External Start Conditions.

Y1-Y2: Feedback Loop.

Output 31-32 must not be used as a safety circuit: It can be used for non-hazardous machine movement.

Functional Diagram of the XPSBC Module

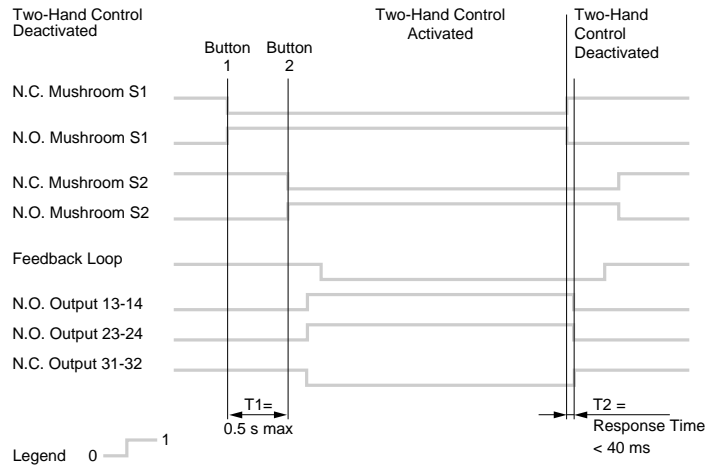

PREVENTA™ XPS Safety Relays

Type 2 Perimeter Light Curtain

Operating Principle

The XPSCE safety relays are used with specific XU2S thru-beam photoelectric sensors to form a Category 2 light curtain that conforms to European standards EN 61496 parts 1 and 2, and EN 60825-1. This allows the system to be used as a perimeter light curtain for body detection.

Up to 4 pairs of specific XU2S thru-beam photoelectric sensors can be wired into the XPSCE to form a protected zone up to 47 inches (1200 mm) high and 26 feet (8 meters) long. These photoelectric sensors have a test input and are programmable to light or dark operate and are available in NPN or PNP types.

When the light curtain is activated by the start command, and none of the light beams are broken, the main circuit is closed by the outputs from the XPSCE. Breaking one or more of the light beams opens the outputs of the XPSCE safety relay, dropping out the main circuit.

After the light beams are cleared, an NPN solid state output (OSSD) closes to inform the PLC or other control system that a Start command or sequence is required to restart the light curtain. This OSSD output is not a safety output. Restarting of the light curtain is only allowed by a new start command or start sequence (a restart interlock function).

An internal electronic fuse protects the XPSCE module against external faults or short circuits. This electronic circuit resets itself automatically upon the removal of the fault.

A “muting” function is available on all XPSCE modules. The muting function will temporarily suspend the safety function of the light curtain for a limited time, provided certain pre-determined conditions exist. The muting function can be used to allow material transfer equipment (i.e.: Automatic Guided Vehicles or AGV's) to pass through the light curtain without tripping the main circuit (see diagram below).

The muting would be accomplished as follows:

1. The material transfer equipment approaches the light curtain.
2. Its leading edge would break beam of MS1 to indicate its presence
3. Light curtain would be muted to allow it to pass
4. Material transfer equipment continues on and breaks beam of MS2
5. When trailing edge of material transfer equipment stops blocking MS2, light curtain resumes normal operation.

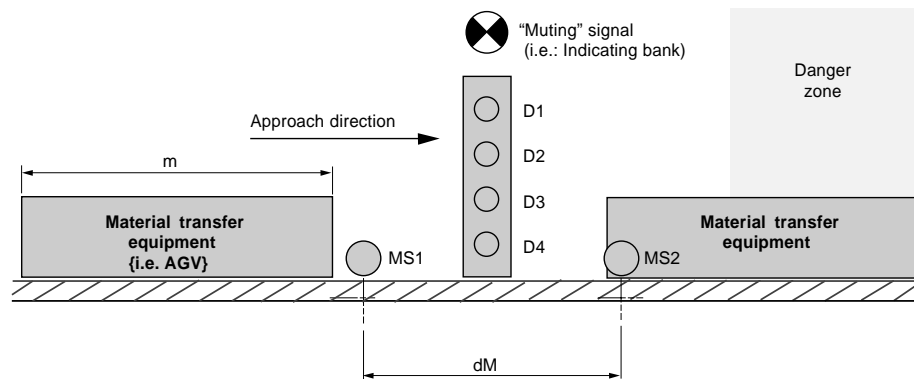

D1, D2, D3, D4: XU2-S photoelectric sensors for monitoring function.
 MS1, MS2: photoelectric sensors for “muting” function.
 m = length of material transfer equipment (AGV).
 dM = distance between MS1 and MS2.

Requirements for use of the “Muting” Function

- The “muting” sensors (MS2) must be of the thru-beam type XU2M18PP340, or the polarized retro-reflective XU9M18PP340 and must be used in dark operate mode.
- $dM \leq m$ to maintain continuity of the “muting” function during the material transfer.
- Avoid the entry of personnel during the “muting” period. The “muting” period is identified by warning lights, such as the XVB including indicating banks or beacons, connected to the muting signaling outputs of the XPSCE.

PREVENTA™ XPS Safety Relays Type 2 Perimeter Light Curtain

Technical Data

Module Type		XPSCE
Category, per EN 61496-1 and EN 60825-1		Category 2
Power Supply		
Voltage	V	24 Vac/dc
Voltage limits		- 20...+20% (24 Vdc), - 20...+10% (24 Vac)
Frequency	Hz	50/60
Power Consumption 24 V	VA	< 11
Module Fuse Protection		internal electronic
Detector Inputs		
Number of inputs to be monitored		1 to 4 (terminals Z1, Z2, Z3, Z4)
Input voltage	V	24 Vdc
Detector supply voltage	V	24 Vdc (terminal +U)
Detector supply current	mA	40
Muting Function Inputs		
Number of muting inputs		1 (terminal M1)
Input voltage	V	24 Vdc
Maximum current	mA	40
Outputs		
Voltage reference		Relay Hard Contacts
No. and nature of safety circuits		2 N.O. (13-14, 23-24)
AC-15 Breaking capacity	VA	C300: inrush 1800, sealed 180
DC-13 Breaking capacity		24 V/1.5 A - L/R = 50 ms
Max thermal current (Ithe)	A	2.5
Output fuse protection per IEC 947-5-1, VDE 0660 Part 200 A	A	4 A fuse
Minimum current	mA	10
Minimum voltage	V	17
Muting Signaling Outputs		
Number		2 (terminals H1, H2)
Maximum power		5 W / 24 Vdc
Additional OSSD Control Output		
Number and type		1 solid state NPN (terminals Y33-Y34)
Breaking capacity		24 V / 20 mA, 48 V / 10 mA
Electrical Life		See page 78
Response Time on input change of state	ms	<20
Rated Insulation Voltage (Ui)	V	300 (Pollution degree 2 per IEC 947-5-1, DIN VDE 0110 Parts 1 and 2)
Rated Impulse Withstand Voltage (Uimp)	kV	4 (Overvoltage category III per IEC 947-1, DIN VDE 0110 Parts 1 and 2)
LED Display		4
Operating Temperature		+ 14 °F to + 130 °F (- 10 °C to + 55 °C)
Storage Temperature		- 13 °F to + 185 °F (- 25 °C to + 85 °C)
Degree of Protection per IEC 529		
Terminals		IP 20
Housing		IP 40
Connection Type		Captive screw-clamp terminals. Maximum wire size: 1-12 AWG (1 x 4 mm ²) without cable end, 2-14 AWG (2 x 2.5 mm ²) with cable end

Technical Data – XU2S Thru-beam Photoelectric Sensors

Certification		CE per EN 61496-1 and EN 60825-1
Rated Supply Voltage	V	12-24 dc (reverse polarity protected)
Voltage Limits	V	10-30 dc
Current Switching Capacity	mA	< 100 (short circuit protected and overload protected)
Voltage Drop	V	< 1.5
Current Consumption, no-load	mA	< 35
Maximum Switching Capacity	Hz	500
Time Delay	ms	≤ 1
Vibration Resistance		7 g (f=10...55 Hz), conforming to IEC 68-2-26
Shock Resistance		30 g, along 3 axes: 3-times, conforming to IEC 68-2-27
Materials		Enclosure: nickel-plated brass (infra-red detectors), Lenses PMMA
Nominal Sensing Distance Infra-red detectors		26.24 ft. (8 m)
Operating Temperature Infra-red detectors		- 13 °F to + 130 °F (- 25 °C to + 55 °C)
Storage Temperature		- 40 °F to + 158 °F (- 40° to + 70 °C)
Degree of protection per IEC 529		IP 67
Connection Type		
Cable		PVC cable, 0.20 in (5 mm) diameter, 4 x 22 AWG (0.34 mm ²). For thru-beam transmitter, 3 x 22 AWG (0.34 mm ²)
Connector		M12 male, 4-pin connector

PREVENTA™ XPS Safety Relays

Type 2 Perimeter Light Curtain



XPSCE●●●●●

XPS Safety Relays and Thru-Beam Photoelectric Sensors with Test Input

The XPSCE and up to 4 of the XU2S photoelectric sensors below can be used to make a Type 2 perimeter light curtain for body detection that meets European standard EN 61496 parts 1 and 2, and EN 60825-1.

The muting function of the XPSCE allows for the transfer of materials through the light curtain without opening the main circuit. This function requires the use of two additional sensors, either the thru-beam type XU2M18PP340, or polarized retro-reflective type XU9M18PP340 and must be used in the dark operate mode. For more information, refer to page 134 of this catalog or the instruction manual.

Applying Type 2 Perimeter Light Curtains

When designing an application or installing any light curtain, the user must follow all applicable codes, standards and regulations. Some of the US standards which must be followed are: ANSI B11.1 through B11.20, OSHA 29 CFR 1910, and ANSI/RIA R15.06 standards. Some of the European standards which must be followed are: EN 292-1, EN 292-2, EN 60204-1, pr EN 999, EN 294, and EN 811. There may be other national and local standards that may also need to be followed.

Appendix A (pages 173 to 183 of this catalog) provides information on the installation, use, maintenance and testing of light curtains. This section must be read and followed prior to installation and use of any light curtain.

XPS Safety Relays

Use only XU2S Photoelectric Sensors as listed below.

Description	Type of associated detectors	No. of safety circuits	Additional solid state outputs	Power supply	Catalog number	Weight lb. (kg)
Safety modules for monitoring photoelectric sensors with test input	PNP	2	1	24 Vdc	XPSCEP5141	12 (0.350)
	NPN	2	1	24 Vdc	XPSCE5141	12 (0.350)



XU2S18●P340L5



XU2S18●P340D



XU2S18●P340WL5



XU2S18KP340L5T



XU2S18KP340WL5T



XU2S18●P340DR



XU2S18●P340WL5R

Thru-Beam Photoelectric Sensors (DC) with Test Input

For use with XPSCE safety relays listed above.
All receivers are programmable for light or dark switching.
Range is 26.2 ft. (8 m) for infra-red sensing.
Cable length is 16.4 ft. (5 m).
Connector is 4 pin micro type — DC.

Description ★	Beam type	Body type	Connection	Catalog number	Weight lb. (kg)
Thru-beam pair PNP■ (transmitter + receiver)	Infra-red	Straight	cable	XU2S18PP340L5	17 (0.485)
			connector	XU2S18PP340D	5.5 (0.155)
		90° head	cable	XU2S18PP340WL5	17 (0.485)
			connector	XU2S18PP340WD	5.5 (0.155)
Thru-beam pair NPN▲ (transmitter + receiver)	Infra-red	Straight	cable	XU2S18NP340L5	17 (0.485)
			connector	XU2S18NP340D	5.5 (0.155)
		90° head	cable	XU2S18NP340WL5	17 (0.485)
			connector	XU2S18NP340WD	5.5 (0.155)
Thru-beam transmitter only●	Infra-red	Straight	cable	XU2S18KP340L5T	8.3 (0.235)
			connector	XU2S18KP340DT	2.6 (0.075)
		90° head	cable	XU2S18KP340WL5T	8.3 (0.235)
			connector	XU2S18KP340WDT	2.6 (0.075)
Thru-beam receiver only (PNP)■	Infra-red	Straight	cable	XU2S18PP340L5R	8.8 (0.250)
			connector	XU2S18PP340DR	2.8 (0.080)
		90° head	cable	XU2S18PP340WL5R	8.8 (0.250)
			connector	XU2S18PP340WDR	2.8 (0.080)
Thru-beam receiver only (NPN)▲	Infra-red	Straight	cable	XU2S18NP340L5R	8.8 (0.250)
			connector	XU2S18NP340DR	2.8 (0.080)
		90° head	cable	XU2S18NP340WL5R	8.8 (0.250)
			connector	XU2S18NP340WDR	2.8 (0.080)

■ For use with XPSCEP5141.
▲ For use with XPSCE5141.

● For use with either XPSCEP5141 or XPSCE5141.
★ Dimensions for sensors on page 171.



PREVENTA™ XPS Safety Relays Type 2 Perimeter Light Curtain

XPSCE Functional diagram

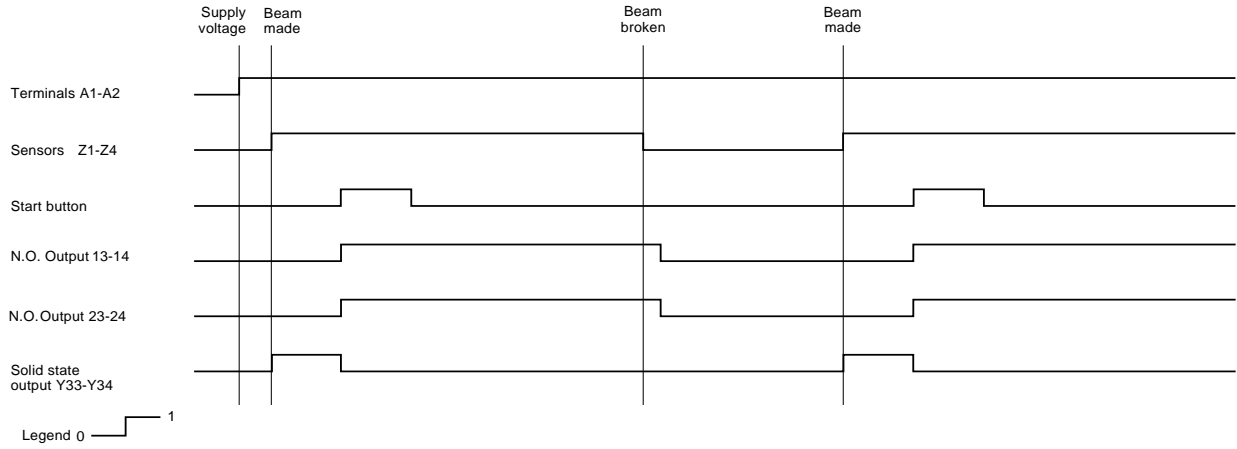

Functional diagram with “muting” function

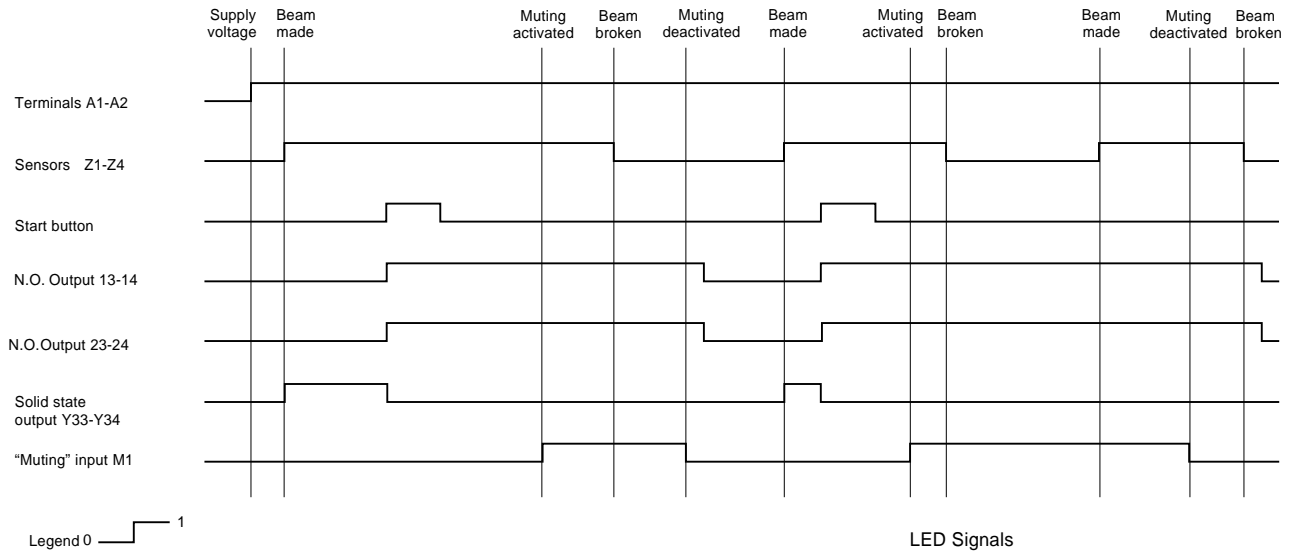

LED Signals

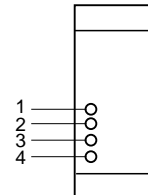

- 1 Supply voltage A1-A2, internal electronic fuse state
- 2 Re-start signal
- 3 Safety output closed
- 4 Safety output open

PREVENTA™ XPS Safety Relays

Type 2 Perimeter Light Curtain

XPSCEP WIRING DIAGRAMS AND CONNECTIONS

With 4-pairs of XU2S sensors and using "muting" function

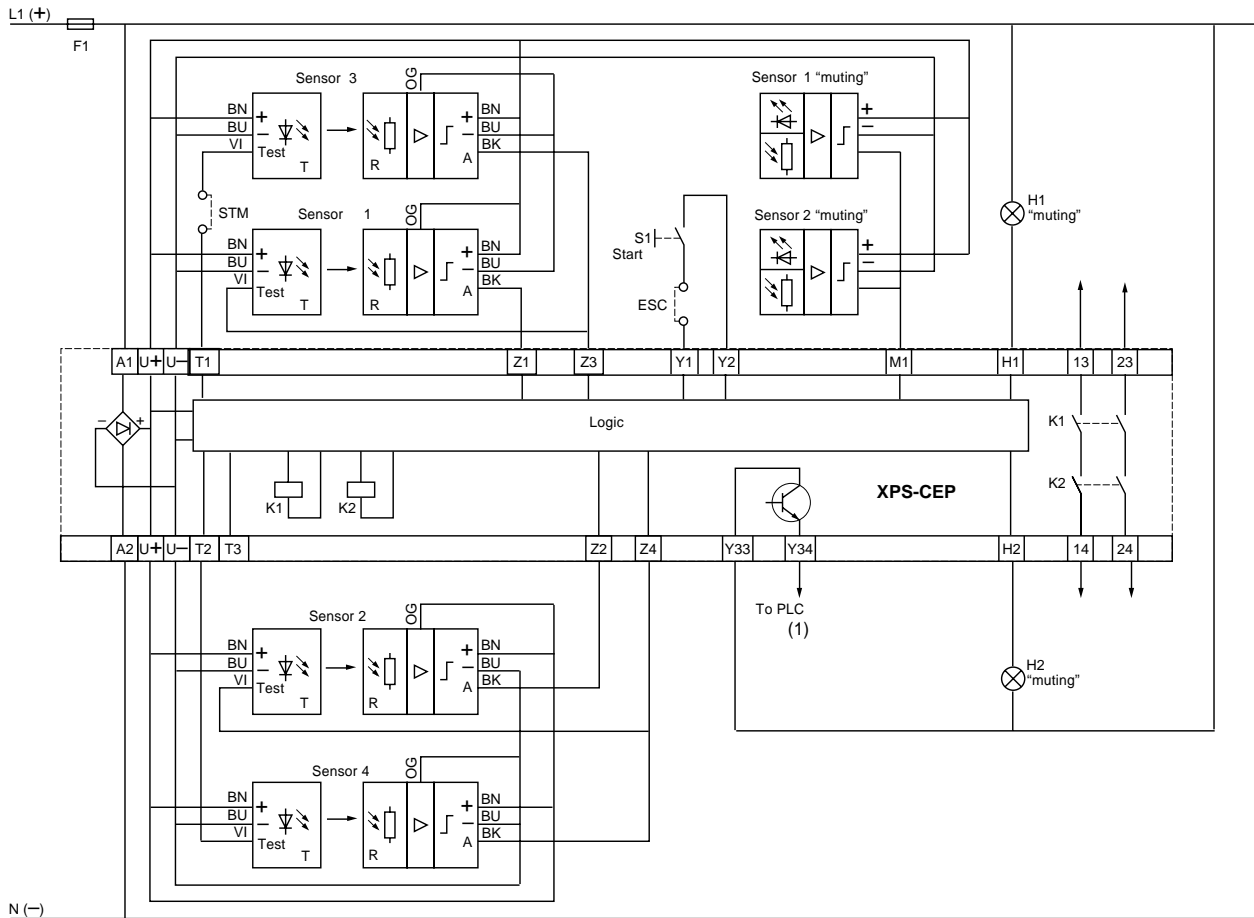

XU2S sensors can be programmed to operate in light or dark switching mode (example with sensors 1 and 3 programmed for dark switching sensors 2 and 4 programmed for light switching).

Y1 - Y2 Feedback loop.

ESC: External start conditions

STM: For measuring the stopping time.

(1) Re-start instruction required.

H1 and H2: XUB Indicating Banks or Beacons

PREVENTA™ XPS Safety Relays Type 2 Perimeter Light Curtain

XPSCEP Wiring Diagrams and Connections

With 1 pair of XU2S Sensors (dark switching)

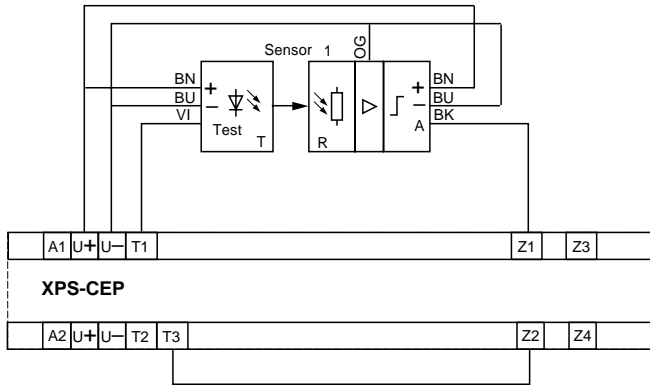

With 2 pairs of XU2S Sensors (dark switching)

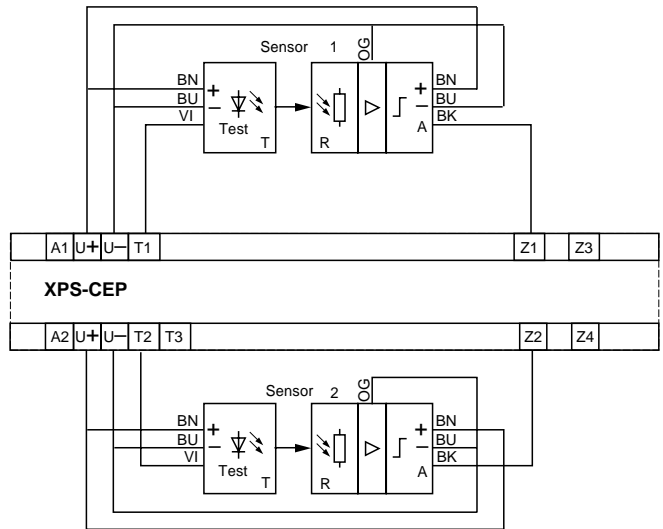

With 3 pairs of XU2S Sensors
(2-dark switching, 1-light switching)

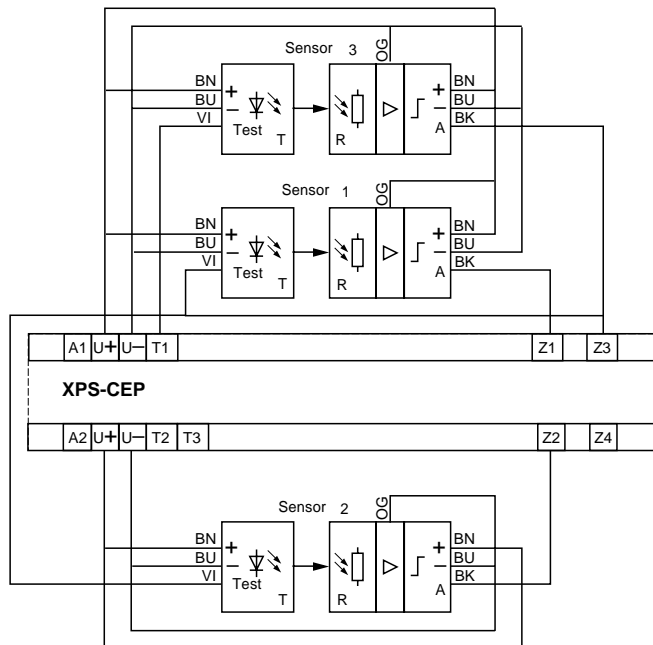

With 4 pairs of XU2S Sensors
(2-dark switching, 2-light switching)

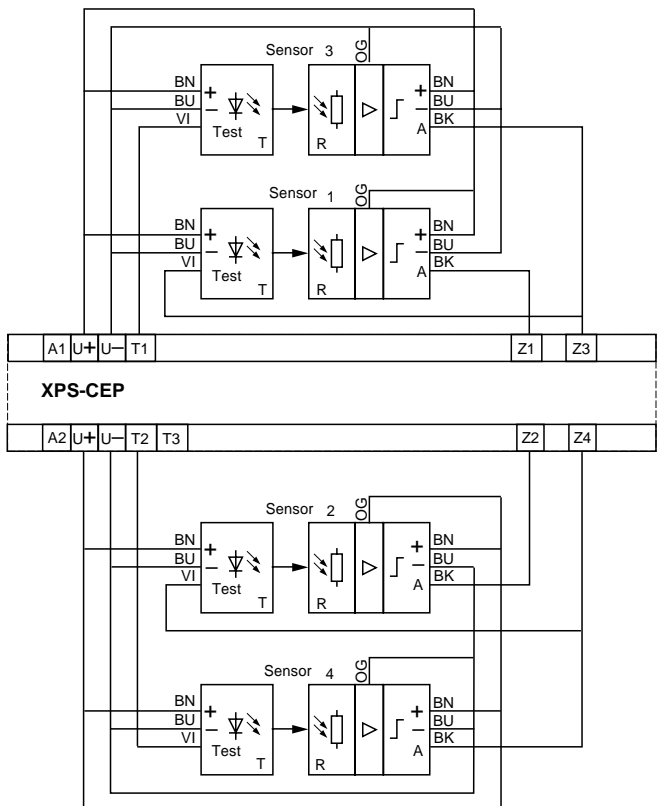

PREVENTA™ XPS Safety Relays

Type 2 Perimeter Light Curtain

OPERATION, CURVES, AND CONNECTIONS

XU2S Thru-Beam Photoelectric sensors

Operation

Output state (PNP or NPN)
Indicator: yellow LED illuminated when detector output is ON



Infra-red detection curve

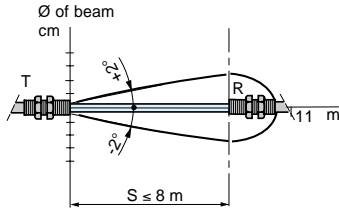

Test for correct operation

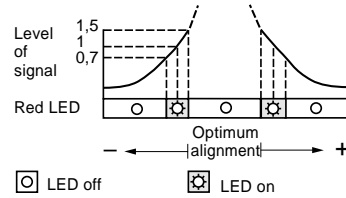

Wiring diagrams (3-wire -Vdc) with cable

Transmitter

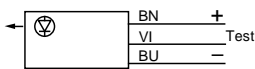

Receiver

Light switching (no object present)

PNP output

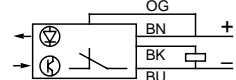

NPN output

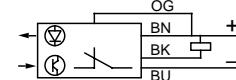

Receiver

Dark switching (no object present)

PNP output

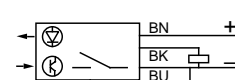

NPN output



With connector

Transmitter

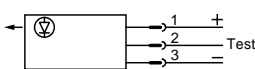

Receiver

Light switching (no object present)

PNP output

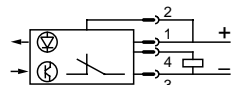

NPN output

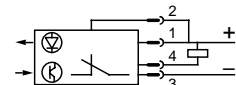

Receiver

Dark switching (no object present)

PNP output

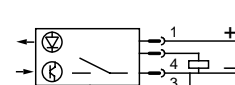

NPN output

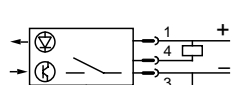

Cable wiring

- (-) BU (Blue)
- (+) BN (Brown)
- (OUT) BK (Black) (receiver)
- (Prog.) OG (Orange) (receiver)
- (Test) VI (Violet) (transmitter)

Connector wiring

Side view of detector pins

Transmitter

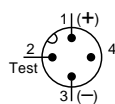

Receiver

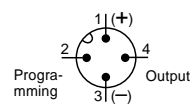

Break test (for transmitter only)

Beam made

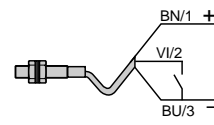

Beam broken

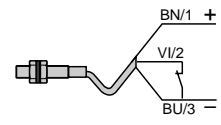

Operating Principle

The XPSVN zero speed safety relay is used for zero speed detection of electric motors. Its primary use is in systems employing one or more of the following:

- Directional controls for reversing motors
- Electrical locking of machinery doors and guards with safety interlocking devices. An example would be to energize the solenoid of an XCSE solenoid safety interlock device (locking without power).
- Electrical braking systems that lock the system after it comes to zero speed.
- DC injection brakes.

When coasting to a stop, electric motors generate a residual voltage in their windings, resulting from residual magnetism, and this decreases proportionally to the decrease in motor speed. This residual voltage is monitored by the XPSVN safety relay to detect the motor's zero speed. The wiring between the motor windings and the safety relay are also monitored, to identify a wire break (fault) differently from a zero speed detection. Therefore, a broken or loose wire will not be interpreted as a zero speed condition of the motor.

The XPSVN safety relay is designed for zero speed detection in all types of electrical machinery using AC or DC, single phase or three phase power, which can be controlled by electric motor controls such as adjustable frequency controllers, control components to start under low load (i.e.: low voltage), and brakes which inject direct current (DC) into the windings.

The XPSVN is not compatible with Wound Rotor Motors. These motors are typically used in high HP (1000+) low speed applications, where the additional windings (required for these types of motors) pay for themselves. If power is removed from stator, but rotor is left energized, then transformer coupling between the two could create a small voltage across the stator. This could make the XPSVN think the motor is still turning, which means the safety outputs would never energize or change state. These motors do not have residual magnetism in the rotor that can act as a source of flux for generator effect, in which case the XPSVN may think the motor is at zero speed, and could energize the safety outputs while the motor is still running. Wound Rotor motors are not in common use today, and very rare.

The XPSVN is not designed to detect locked rotor conditions. Here the motor still has voltage applied to it, but in essence has zero speed. Generally, a locked rotor condition is not a safe state for machinery nor the operators. The XPSVN will sense voltage applied to the windings, and will not indicate the motor's "apparent" zero speed. The outputs of the XPSVN will not change state, the gates or guards will not be unlocked, and operators will not be allowed access to the unsafe area.

Two potentiometers, mounted on the face of the module, allow independent adjustment of the switching threshold for each input circuit. This allows adjustment for different types of motors and application requirements. It should be noted that "Zero speed" may not indicate absolute zero speed. This device detects speeds below user adjustable values as set by these potentiometers.

To assist in diagnostics, XPSVN modules incorporate 4 LED indicators and 2 solid state outputs to provide information on the status of the zero speed detection circuit.

A transformer should not be used to connect the motor to terminals Z1, Z2 and Z3 since there is no monitoring of the connection with motor winding via the resistor monitoring

PREVENTA™ XPS Safety Relays

Zero Speed Detection

Technical Data

Module Type		XPSVN
Power Supply		
Voltage	V	24 Vac/dc, 115/230 Vac
Voltage limits		-15... +10% (24 Vdc)
		-15... +15% (115 Vdc)
		-15... +10% (230 Vdc)
Frequency	Hz	50/60
Power Consumption		
24 V	W	< 4
115 V/230 V	VA	< 8
Module Fuse Protection		≤ 4 A external fuse for 115 and 230 V versions ≤ 500 mA external fuse for 24 V versions
Inputs		
Maximum voltage between terminals Z1, Z2, Z3	V	500
Detection threshold	V	0.01 to 0.1 (adjustable)
Outputs		
Voltage Reference		Relay hard contacts
No. and nature of safety circuits		1 N.O. (13-14), 1 N.C. (21-22)
No. and nature of additional circuits		2 solid state
AC-15 Breaking capacity	VA	C300: inrush 1800, sealed 180
DC-13 Breaking capacity		24 V/1.5 A - L/R=50 ms (contact 13-14)
		24 V/1.2 A - L/R=50 ms (contact 21-22)
Breaking capacity of solid state outputs		24 V/20 mA, 48 V / 10 mA
Max thermal current (I _{the})	A	2.5
Output fuse protection	A	4 A fuse; per IEC 947-5-1, DIN VDE 0660 part 200
Minimum current	mA	10
Minimum voltage	V	17
Electrical Life		See page 78
Rated Insulation Voltage (Ui)	V	300 (Pollution degree 2 per IEC 947-5-1, DIN VDE 0110 parts 1 and 2)
Rated Impulse Withstand Voltage (U_{imp})	kV	4 (Overvoltage category III, per IEC 947-5-1, DIN VDE 0110 parts 1 and 2)
LED Display		4
Operating Temperature		+14 °F to +130 °F (-10 °C to +55 °C)
Storage Temperature		-13 °F to +185 °F (-25 °C to +85 °C)
Degree of Protection per IEC 529		
Terminals		IP20
Housing		IP50
Connection Type		Captive screw-clamp terminals. Maximum wire size: 1-12 AWG (1 x 4 mm ²) without cable end, 2-14 AWG (2 x 2.5 mm ²) with cable end.



XPSVN



File E164353
CCN NKCR



File LR44087
Class 3211 03



Ordering Information

Description	No. of Safety Circuits	Solid State Outputs for PLC	Power Supply	Catalog Number*	Weight oz. (kg)
Safety modules for zero speed detection	2	2	24 Vdc	XPSVN1142	18 (0.500)
			115 Vac	XPSVN3442	21 (0.600)
			230 Vac	XPSVN3742	21 (0.600)

Suitable for use in circuits through Category 4 per EN 954-1

*. for high frequency applications, above 60Hz, contact your local Schneider Electric sales office.

Dimensions.....147-148

Wiring Diagrams and Connections XPSVN with 3-Phase AC Motor

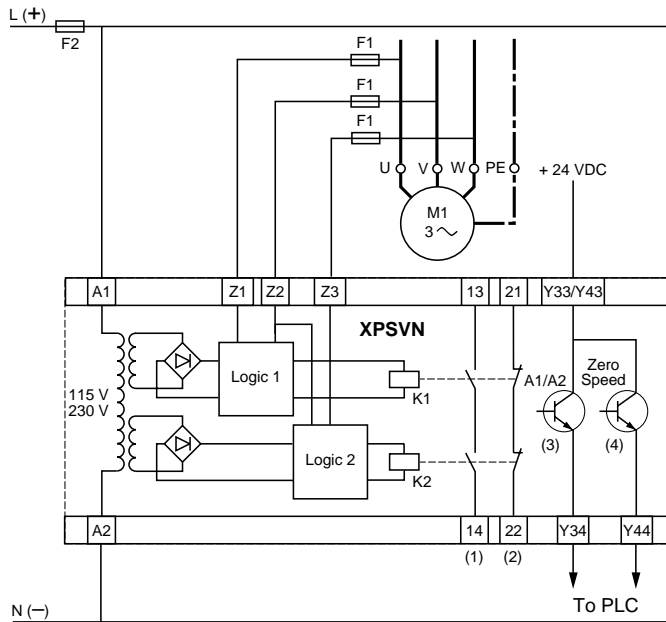

- (1) Contacts are open when motor is running, closed when motor is stopped.
 - (2) Contacts are closed when motor is running, open when motor is stopped.
 - (3) Internal electronic fuse status (Y33/Y43-Y34)
 - (4) Zero speed (Y33/Y43-Y44)
- F1 = 2 A

XPSVN with 3-Phase AC Motor

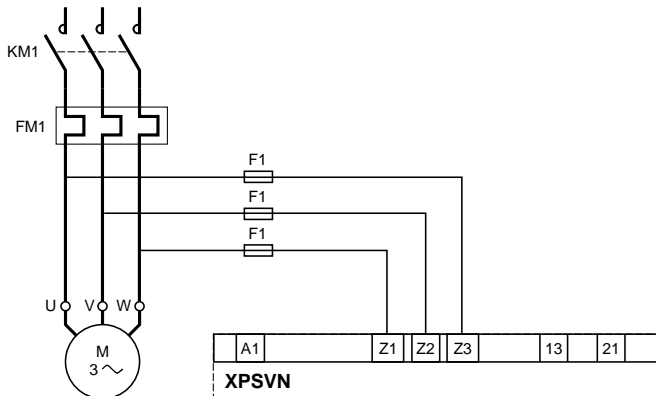

F1 = 2 A

XPSVN with DC Motor

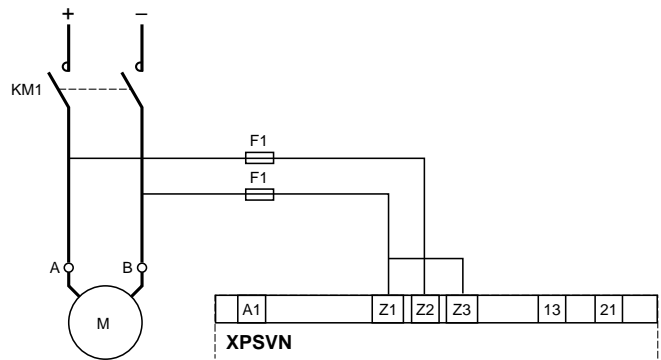

F1 = 2 A

XPSVN with 3-Phase AC Motor and Variable Speed Controller

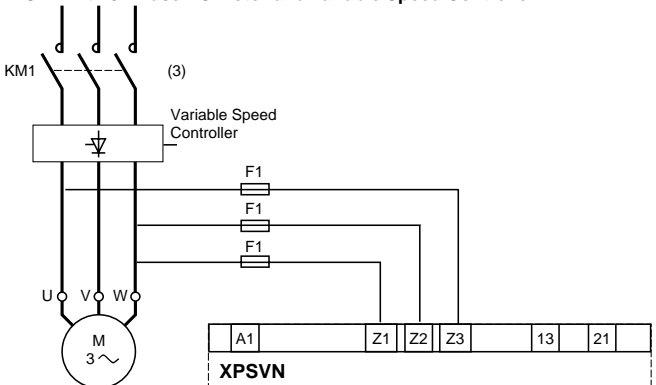

F1 = 2 A

(3) Use an output from the variable speed controller to open KM1 under normal stopping conditions.

LED Signals

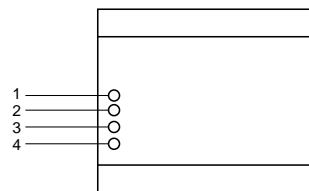

- 1 A1-A2 supply voltage
- 2 Stop detected by channel 1
- 3 Stop detected by channel 2
- 4 Stop detected by both channels within time window

PREVENTA™ XPS Safety Relays Zero Speed Detection

Wiring Diagrams and Connections XPSVN with 3-Phase AC Motor and Star Delta Starting

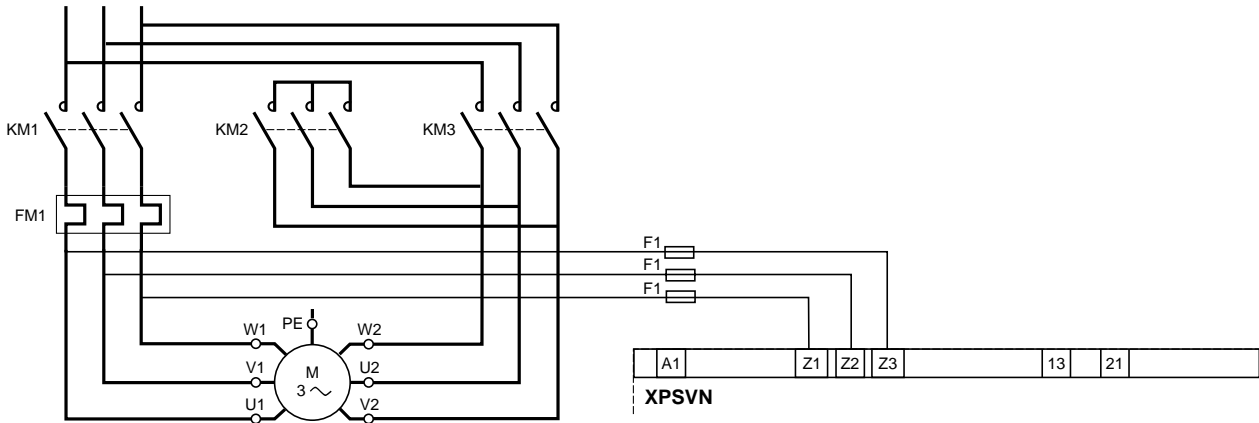

KM1: High speed rotation
KM2: Low speed rotation
KM3: Star

F1 = 2 A

The star contactor (KM3) must be closed after the motor is de-energised, in order to allow detection of zero speed.

XPSVN Functional Diagram

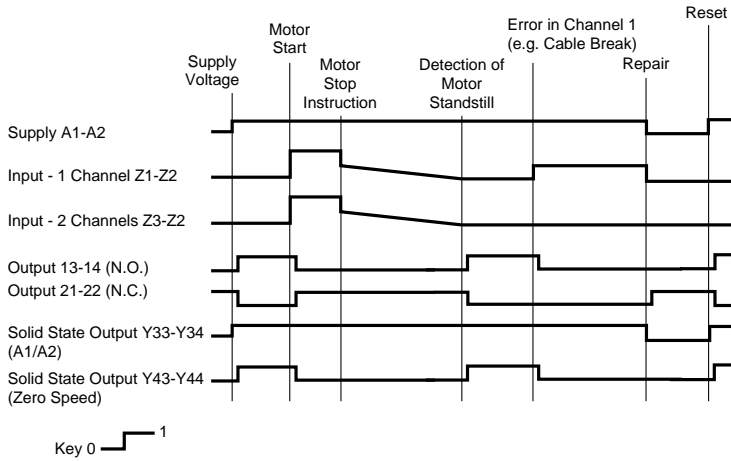

The voltages at terminals Z1, Z2 and Z3 are indicated solely for the purpose of schematic diagram representation.

PREVENTA™ XPS Safety Relays

Zero Speed Detection

Wiring Diagrams and Connections

XPSVN

Example of a safety circuit connecting an XPSVN, XPSFB, XCSE safety interlock switch, a limit switch, a motor starter, a Programmable Controller, and a 3-phase AC motor.

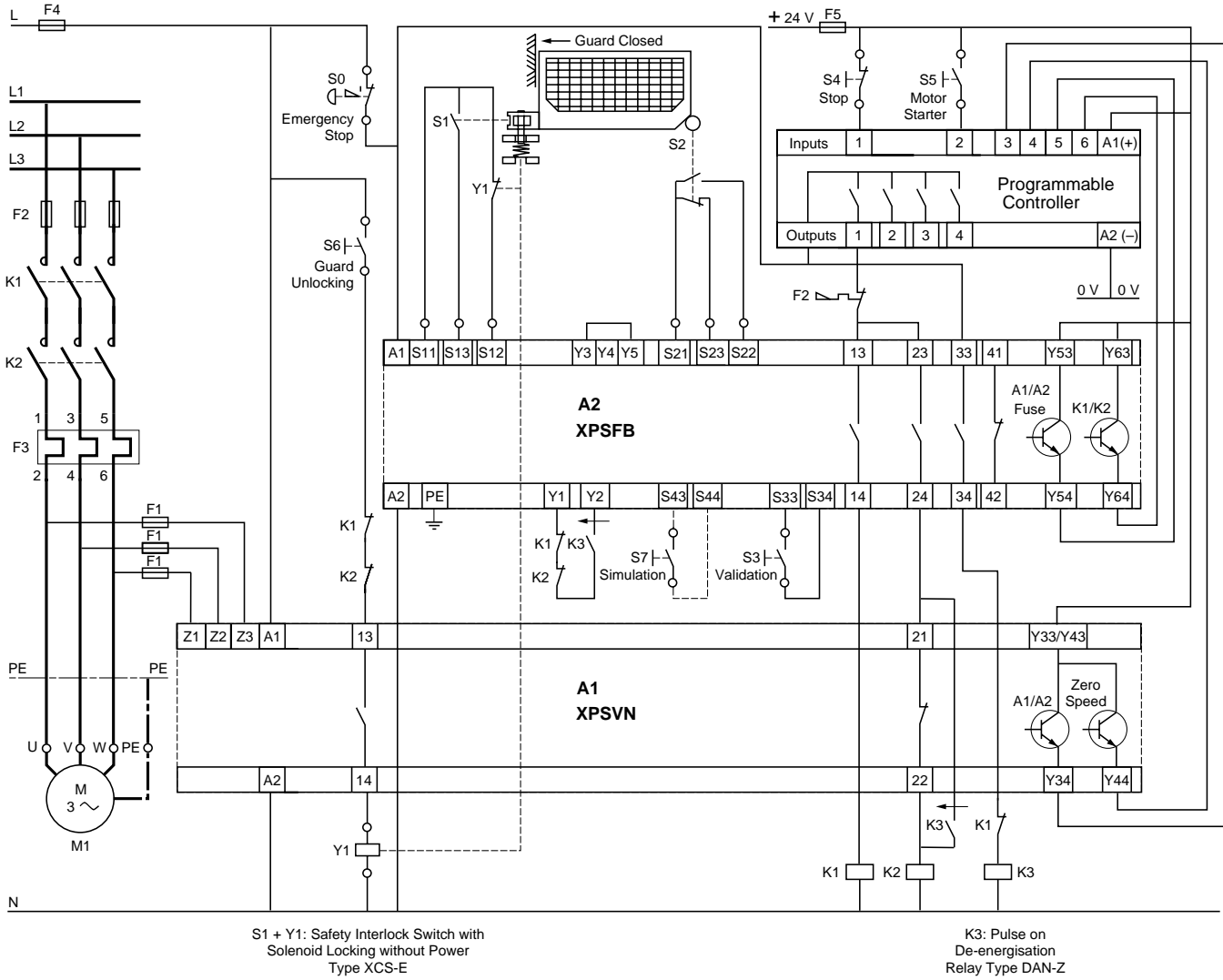

PREVENTA™ XPS Safety Relays Elevator Cabin Position Monitoring

Operating Principle

When an elevator cabin is parked at a landing with the doors open, some elevators automatically correct their position (height), called isoleveling, in relation to the landing in order to compensate for any differences generated by a changing of the load in the elevator cabin such as loading or unloading. During this correction, European Standard EN-81 recommends that the presence of the elevator cabin be checked within a distance of ± 7.87 in (20 cm) of the landing (door unlocking zone), by a safety circuit which will stop the elevator cabin if it moves out of this specified area.

Using XPSDA safety relay to check the presence of the elevator cabin within the specified zone at two points meets the requirement of EN-81.

The XPSDA has two safety outputs for use in the safety circuit, and also has two solid-state outputs which can be used for signaling to a PLC.

To assist in diagnostics and to provide a visual status indication of the safety circuit, the XPSDA modules have four LEDs in the front cover.

The position of the elevator cabin in relation to the landing is detected by two limit switches (with positive/direct opening contacts) mounted in the elevator shaft. When the elevator cabin reaches a preset position and when it is within the acceptable tolerances in relation to the landing, the two safety circuits in the XPSDA safety relay close and allow the isoleveling of the elevator cabin with the doors open. Any change in one of the input signals (which means the elevator cabin is outside of the specified zone), or a detection of a fault (i.e.: break in the electrical wiring or a short circuit) causes the safety outputs of the XPSDA safety relay to open and stop the elevator cabin from any further movement.

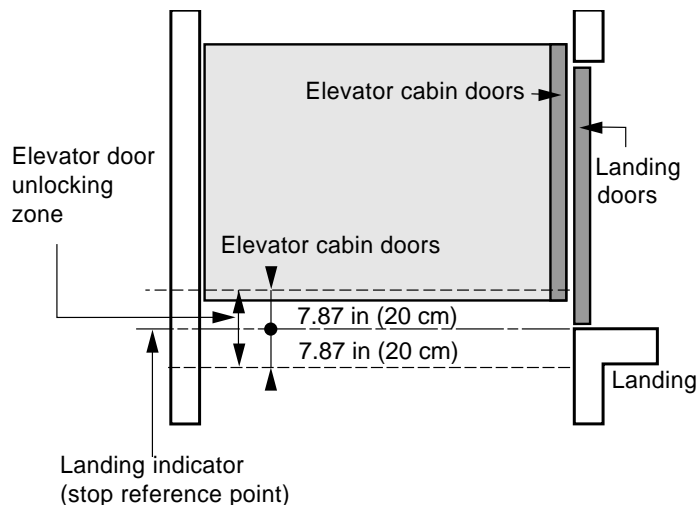

PREVENTA™ XPS Safety Relays

Elevator Cabin Position Monitoring

Technical Data

Module Type		XPSDA
Category, per EN 954-1		Category 4
Power Supply		
Voltage	V	24 Vac/dc, 115/230 Vac
Voltage limits		-20...+20% (24 Vdc), -20...+10% (24 Vac), -15...+15% (115 Vac), -15...+10% (230 Vac)
Frequency	Hz	50/60
Power Consumption		
24 V	VA	< 9
115 V / 230 V	VA	< 10
Module Fuse Protection		internal electronic
Inputs		S1: 1 N.C. + N.C., S2: 1 N.C. + N.C.
Control Unit Voltage between S11-S12, S21-S22, or S11-B1		
24 Vac Version	V	24
115 V or 230 V Version	V	48
Minimum voltage and current between terminals S11-S12, S21-S22 (inputs A and B)		
U min/I min - 24 Vdc (20 °C) version		16 V / 70 mA
U min/I min - 115 V / 230 Vac (20 °C) version		41 V / 25 mA
Calculation of wiring resistance RL between terminals S11-S12 and S21-S22 as a function of internal voltage supply U int (terminals S11-S12)	Ω	$RL_{max} = \frac{U_{int} - U_{min}}{I_{min}}$ Ue = True voltage applied to terminals A1-A2 U int = Supply voltage Ue - 3 V (24 V version) U int between 42 V and 45 V, with typical value = 45 V (115 V, 230 V version) Max RL must not exceed 50
Synchronization Time between inputs A and B automatic start, terminals S33-S34 and Y3-Y4 jumpered.	s	0.5
Outputs		
Voltage reference		Relay Hard Contacts
No. and nature of safety circuits		2 N.O. (13-14, 23-24)
No. and nature of additional circuits		2 solid-state
AC-15 Breaking capacity	VA	C300: inrush 1800, sealed 180
DC-13 Breaking capacity		24 V/1.5 A - L/R = 50 ms
Solid-state output breaking capacity		20 mA / 24 V
Max thermal current (Ithe)	A	2.5
Output fuse protection per IEC 947-5-1, VDE 0660 Part 200 A	A	4 A fuse
Minimum current	mA	10
Minimum voltage	V	17
Maximum total thermal current	A	5
Electrical Life		See page 78
Response Time on input opening	ms	<40
Rated Insulation Voltage (Ui)	V	300 (Pollution degree 2 per IEC 947-5-1, DIN VDE 0110 Parts 1 and 2)
Rated Impulse Withstand Voltage (Uimp)	kV	4 (Overvoltage category III per IEC 947-1, DIN VDE 0110 Parts 1 and 2)
LED Display		4
Operating Temperature		+ 14 °F to + 149 °F (- 10 °C to + 65 °C)
Storage Temperature		- 13 °F to + 185 °F (- 25 °C to + 85 °C)
Degree of protection per IEC 529		
Terminals		IP 20
Housing		IP 50
Connection Type		Captive screw-clamp terminals. Maximum wire size: 1-12 AWG (1 x 4 mm ²) without cable end, 2-14 AWG (2 x 2.5 mm ²) with cable end

PREVENTA™ XPS Safety Relays Elevator Cabin Position Monitoring

Ordering Information and Diagrams



Description	No. of Safety Circuits	Static outputs to PLC	Power Supply	Catalog Number	Weight oz. (kg)
Safety modules for monitoring elevator cabin position	2	2	24 Vac / dc	XPSDA5142	12 (0.350)
			115 Vac	XPSDA3442	16 (0.450)
			230 Vac	XPSDA3742	16 (0.450)

XPSDA Wiring Diagrams and Connections

XPSDA with an elevator control system

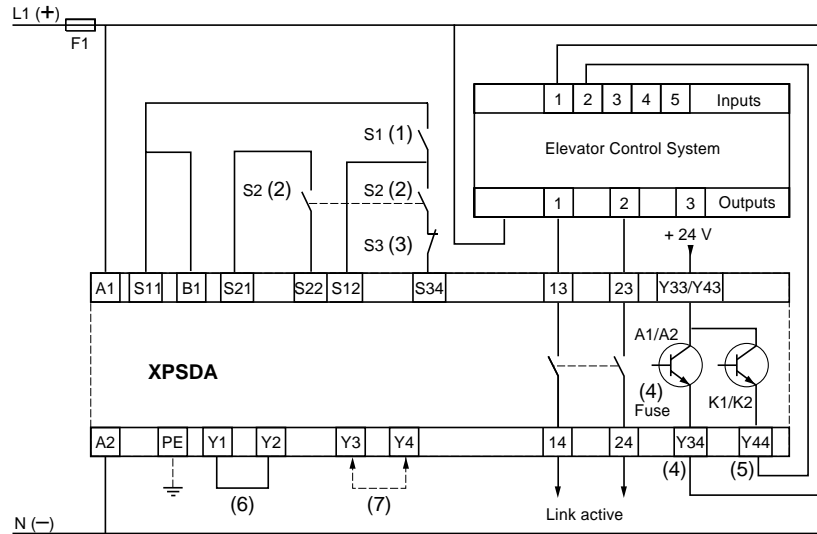

- (1) Limit switch S1 (cabin position)
- (2) Limit switch S2 (cabin position)
- (3) Enable instruction given by the elevator control system.
- (4) Operating state of internal electronic fuse
- (5) Outputs states (only allowed for functions not relating to safety)
- (6) Feedback loop
- (7) Without Start signal monitoring (Y3-Y4 linked)

XPSDA Functional Diagram

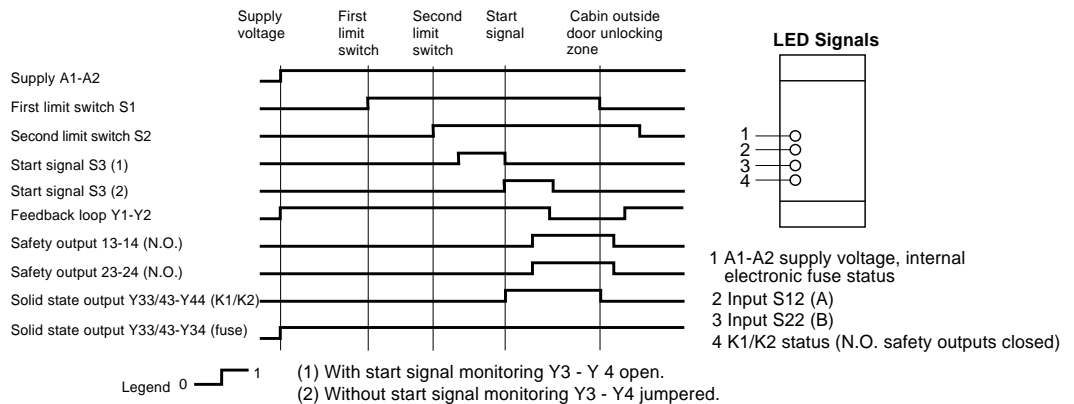

UL File: E164353
CCN: NKCR

SP File: LR44087
Class: 3211 03

CE

Dimensions 147-148

PREVENTA™ XPS Safety Relays

Braking Distance Monitoring of Linear Presses

Principle

The GNKL safety relay is used to monitor the braking distance on all types of linear presses: hydraulic, pneumatic, and mechanical. It monitors the braking distance before production starts, as soon as the press receives either a two-hand control command or light curtains are turned on.

This module must be connected to 2 limit switches:

- Limit switch S2, which detects top dead center,
- Limit switch S3 which detects the presence of normal braking distance when the test cycle is performed after power-up (before production starts). In order for the slide to reach high speed, limit switch S3 must be placed approximately midway of the total tool travel.

The permissible braking distance determines the length (S) of the linear cam, which activates limit switch S3. Length S is usually determined by the linear press manufacturer, by providing for the least favorable braking conditions (i.e.: maximum tool weight, speed and travel, or high oil temperature).

The GNKL safety relay operates only during the first press cycle following power-up: cycle test.

Case 1: Normal Braking Distance

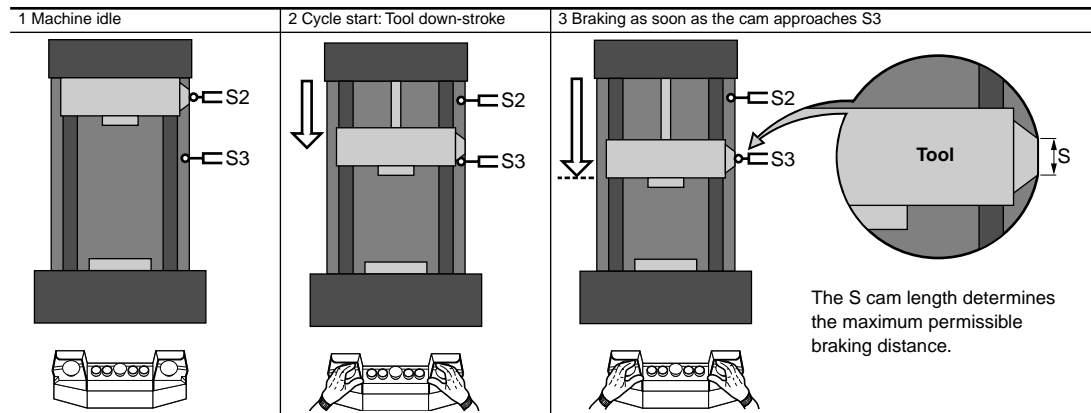

The braking distance does not exceed length S. In this case, the tool stops at the position described in 3 as long as the control sequence provided by the control station is valid. A new control sequence must be given in order for the following cycle to be started.

The GNKL safety module will perform the correct braking distance test at the next power-up.

Second Case: Abnormal Braking Distance (wear, hydraulic leak, improper load)

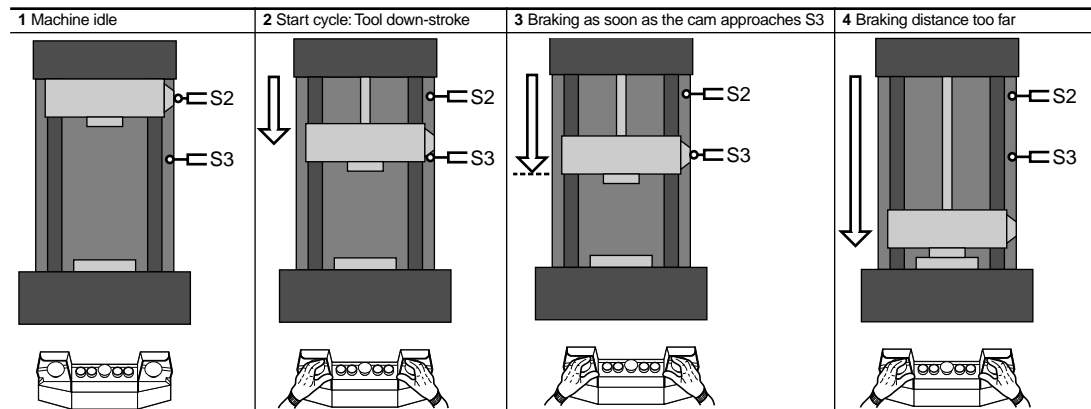

During the test cycle, the braking distance exceeds length S. In this case, the tool is in the position described in 3. Limit switch S3 changes state and the tool moves down, then stays at bottom dead center, the position described in 4. The slide cannot move back up, even if a new start sequence is given by the control station. It can be raised to top dead center only using the “manual raise” button. The next cycle is inhibited. Maintenance intervention is required at this point. Production cannot resume until the completion of a successful test cycle (normal braking distance).

PREVENTA™ XPS Safety Relays

Braking Distance Monitoring of Linear Presses

Excerpts from Standard EN 693

6.4 Hydraulic Systems

6.4.1 All possibilities for failure of the hydraulic circuit and its various commands must be considered at the design level. All components must have high ratings, appropriate for the intended application. As often as possible, monitoring or operational safety checks must be provided for the critical circuit components.

6.4.2 The design and manufacture of the hydraulic circuit must be resistant to the gravitational effects of pressure drops or insufficient pressure, which must not cause hazardous movement.

6.4.3 Controlled down-stroke under the effect of gravity is often deliberately provided to facilitate rapid tool closure. In this case, all the piston cylinder oil must pass through the control valve(s) to obtain a **redundant monitored system**.

6.6.4 Adjustment means whose modification can pose a hazard, such as the travel length adjustment system, must be equipped with a reliable locking device, a means of redundant anchoring which makes adjustment without a special tool impossible, or a device that ensures an equivalent level of safety, such that adjustments can be modified only by qualified personnel.

7.1.5 **If an electrical equipment fault can create an untimely and hazardous situation** (notably an out of time stroke), appropriate measures to avoid this type of hazard must be taken, such as the following:

- Mechanical safety precautions on the machine,
- Locking of electrical circuits controlling the motion of the machine,
- Circuits with control or safety functions, such as redundancy and automatic monitoring.

PREVENTA™ XPS Safety Relays

Braking Distance Monitoring of Linear Presses

Technical Data

Module Type		GNKL
Power Supply		
Voltage	V	24 Vac/dc, 120/230 Vac
Voltage limits		-0...+10 % (24 V) -10...+6 % (120, 230 V)
Frequency	Hz	50/60 (120 V), 50 (230 V)
Power Consumption	VA	< 6
Outputs		
Voltage Reference		Relay hard contacts
No. and nature of safety circuits		1 N.O. (8-13) closing motion, 2 N.O. (10-15, 1-14) + 1 N.C. (2-4)
No. and nature of additional circuits		-
AC-15 Breaking capacity	VA	C300: inrush1800, sealed 180
DC-13 Breaking capacity		24 V/2 A - L/R = 50 ms
Max thermal current (Ithe)	A	2.5
Output fuse protection per IEC 947-5-1, VDE 0660 Part 200	A	2 A fuse
Minimum current	mA	10
Minimum voltage	V	17
Electrical Life		See page 78
Response Time	ms	< 20
Rated Insulation Voltage (Ui)	V	300 (Pollution degree 2 per IEC 947-5-1, DIN VDE 0110 Parts 1 and 2)
Rated Impulse Withstand Voltage (Uimp)	kV	4 (Overvoltage category III, per IEC 947-1, DIN VDE 0110 Parts 1 and 2)
LED Display		8
Operating Temperature		+ 14 °F to + 130 °F (- 10 °C to + 55 °C)
Storage Temperature		- 13 °F to + 185 °F (- 25 °C to + 85 °C)
Degree of Protection per IEC 529		
Terminals		IP 20-5
Housing		IP 40
Polycarbonate Housing		
Type		Plug-in
No. terminals		20
Connection		
Type		Captive screw-clamp terminals. Maximum wire size: 2-14 AWG (2 x 2.5 mm ²) without cable end, 2-16 AWG (2 x 1.5 mm ²) with cable end, minimum diameter of 0.02 in. (0.5 mm) (24 AWG)

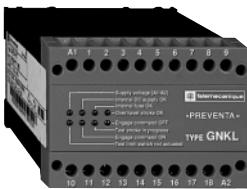

GNKL

Ordering Information

Description	Display	Power Supply	Catalog Number	Weight oz. (kg)
Safety Modules for Braking Distance Monitoring on Linear Presses	8 LEDs	24 Vac/dc	GNKL24VACDC	26 (0.750)
		120 Vac	GNKL120VAC	26 (0.750)
		230 Vac	GNKL230VAC	26 (0.750)

Suitable for use in circuits through Category 4 per EN954-1.



Dimensions 147-148

PREVENTA™ XPS Safety Relays

Hydraulic Press Value Monitoring

Hydraulic safety system circuit operating on a linear press.
Monitoring of valves in position 0.

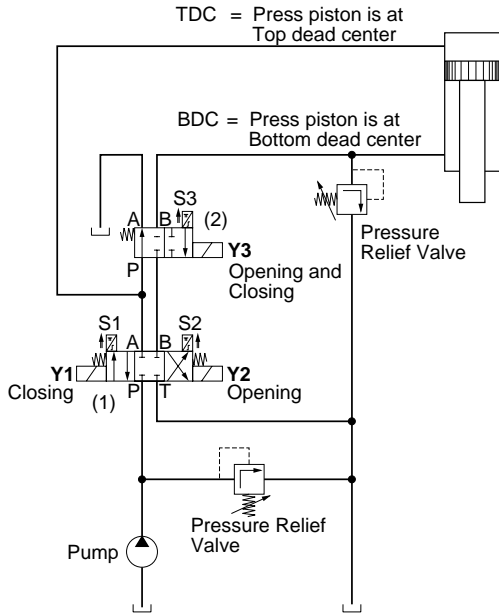

Figure 1

Operating Principle

The XPSPVT safety module is a dedicated module for monitoring hydraulic safety system valves, which control the movements of hazardous machinery.

The operating principle of this module is explained in the circuit diagram of a hydraulic safety system for linear presses (see Figure 1).

This hydraulic safety system features a 3-position valve (see Figure 3) which controls the direction of the up and down stroke of the main operating cylinder of the press (piston). The hydraulic safety system includes a 2-position valve (see Figure 2) to complete the redundancy of the system. This 2-position valve circuit must be activated to enable the up and down stroke of the press piston.

If either of the two valves becomes defective (for example, due to a broken spring or to oil contamination), and the valve shifts from its normal position toward the open position, the XPSPVT module will detect it and prevent resumption of the press piston.

The proximity sensors integrated into the valves detect the valve positions and connected to the XPSPVT module must be actuated (change of contact status) when the valve coils are in the de-energized state (position zero) and the valve closes.

The sensor circuits of the XPSPVT module are designed to allow connection of NPN and PNP proximity sensors or sensing components. Either 2-wire or 3-wire types can be used. These sensing components can also be mechanical hard contacts.

The diagram on page 136 shows how to connect proximity sensors.

The diagram on page 136 also shows the XPSPVT integrated into safety circuits along with two hand controls (XPSBC Preventa Module) or light curtains.

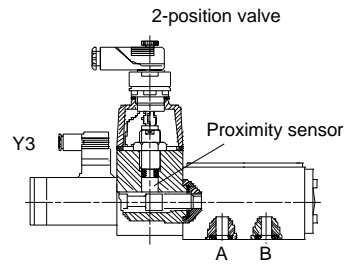

Figure 2

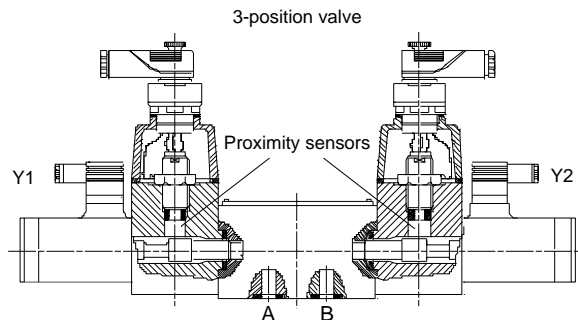
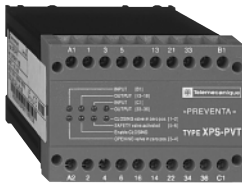

Figure 3

PREVENTA™ XPS Safety Relays Hydraulic Press Valve Monitoring

Technical Data

Module Type		XPSPVT
Power Supply Voltage	V	24 Vdc
Voltage limits		-10... +10% (24 Vdc)
Power Consumption 24 V	W	< 6
Module Fuse Protection		≤ 2 A external fuse
Outputs		
Voltage Reference		Relay hard contacts
No. and nature of safety circuits		2 N.O. (13-14, 33-34), 1 N.C. (21-22)
No. and nature of additional circuits		-
Wiping time	ms	100 (minimum value)
AC-15 Breaking capacity	VA	C300: inrush 1800, sealed 180
DC-13 Breaking capacity		24 V/1.5 A - L/R=50 ms (contact 13-14)
Max thermal current (Ithe)	A	2.5
Output fuse protection	A	4 A fuse; per IEC 947-5-1, DIN VDE 0660 part 200
Minimum current	mA	10
Minimum voltage	V	17
Response Time	ms	< 15
Electrical Life		See page 78
Rated Insulation Voltage (Ui)	V	300 (Pollution degree 2 per IEC 947-5-1, DIN VDE 0110 parts 1 and 2)
Rated Impulse Withstand Voltage (Uimp)	kV	4 (Overvoltage category III, per IEC 947-5-1, DIN VDE 0110 parts 1 and 2)
LED Display		8
Operating Temperature		+14 °F to +130 °F (-10 °C to +55 °C)
Storage Temperature		-13 °F to +185 °F (-25 °C to +85 °C)
Degree of Protection per IEC 529		
Terminals		IP20
Housing		IP40
Polycarbonate Enclosure		
Type		Plug-in terminal strip
Number of terminals		20
Connection Type		Captive screw-clamp terminals. Maximum wire size: 1-12 AWG (1 x 4 mm ²) without cable end, 2-14 AWG (2 x 2.5 mm ²) with cable end."



XPSPVT

Ordering Information

Description	No. of Safety Circuits	Power Supply	Catalog Number	Weight oz. (kg)
Safety modules for dynamic monitoring of hydraulic valves on hydraulic presses	2 N.O. and 1 N.C.	24 Vdc	XPSPVT1180	19 (0.540)

Suitable for use in circuits through Category 4 per EN 954-1



File E164353
CCN NKCR



File LR44087
Class 3211 03



Dimensions 147-148

PREVENTA™ XPS Safety Relays Hydraulic Press Valve Monitoring

XPSPVT Functional Diagram

XPSPVT

Functional diagram of module XPSPVT

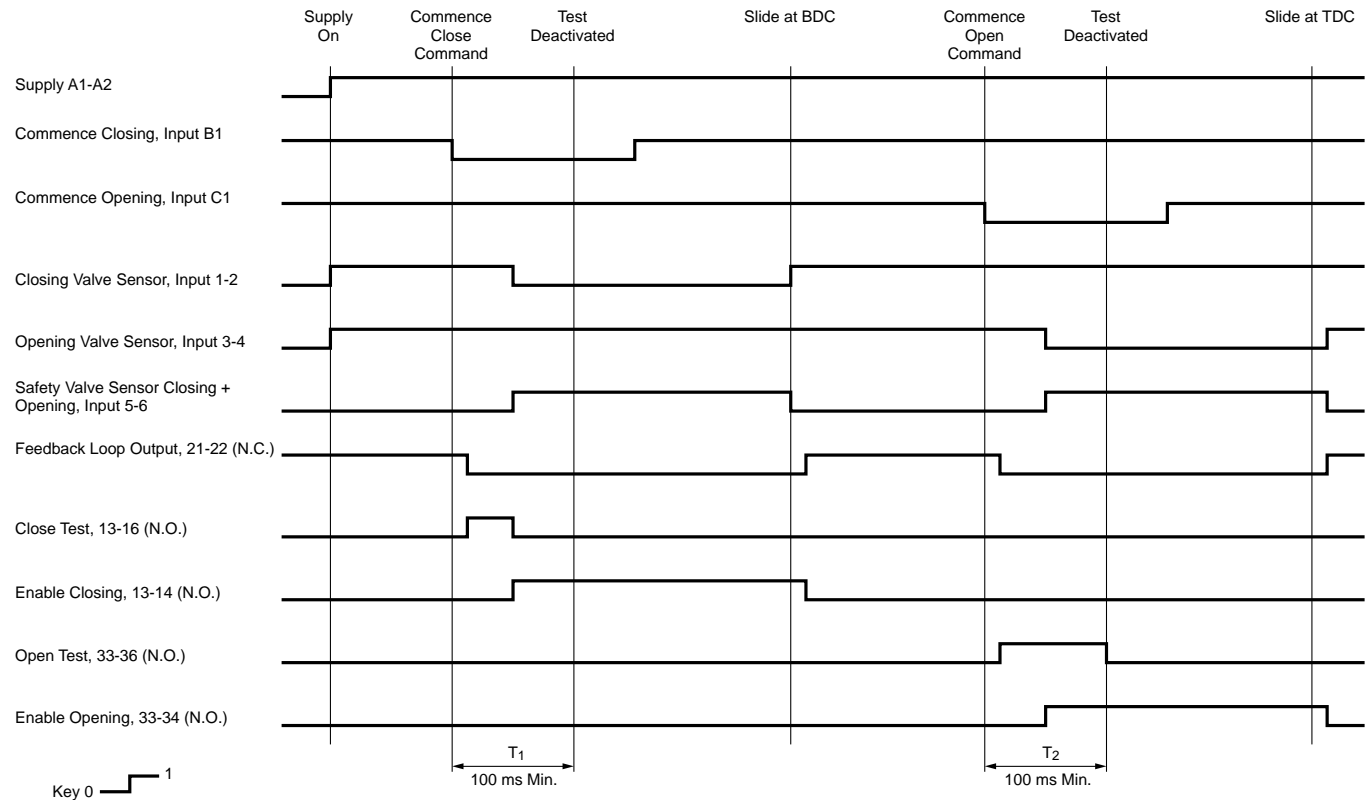

TDC: Top Dead Center
BDC: Bottom Dead Center

LED Signals

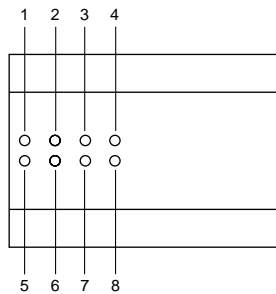

- 1 Close instruction
- 2 Test closure
- 3 Open instruction
- 4 Test opening
- 5 Opening valve (Y2) in position 0
- 6 Enable close
- 7 Safety valve (Y3) activated
- 8 Closing valve (Y1) in position 0

Sensor Status During Press Cycle

	Valve Y1 Sensor S1 (N.O.)	Valve Y2 Sensor S2 (N.O.)	Valve Y3 Sensor S3 (N.C.)
Press ram stopped	Contact closed	Contact closed	Contact open
Press ram moving	Contact open	Contact closed	Contact closed
Press ram closing	Contact closed	Contact open	Contact closed

PREVENTA™ XPS Safety Relays

Double-Body Solenoid Valve Monitoring

Operating Principle

The XPSPVK monitoring module is specially designed for dynamic monitoring of the safety valves in eccentric presses, conforming to European standard EN 692. This standard establishes the specifications related to safety control systems for presses equipped with friction clutches. To meet the requirements of this standard, the clutch/brake control must be monitored dynamically.

This function is provided by a double-bodied solenoid valve (safety valve for presses) which performs the functions of two valves mounted in one body. A diagram of this double-bodied valve, how it works and how it is connected to the XPSPVK, is shown on page 139. The position of the two valve pistons can be monitored by proximity sensors, mechanical limit switches, or pressure switches.

Module XPSPVK checks for the correct operation of the double-bodied safety valves at 3 points in the cycle.

- Start at top dead center (TDC): checks the rest position of the two valves.
- Take-over point (transfer function): checks that the two valves are in the “activated” (energized) position.
- Press stop trigger point: checks that the two valves return to the rest position. Return must be simultaneous for both valves within a defined time period.

To set up an automatic disconnect of the XPSPVK module at the first machine stroke, a N.C. auxiliary contact mounted on the main control contactor or on another contactor/relay, activated at the same time, can be wired to terminals 7 and 8 in parallel with the RESET button.

When a fault is detected during the cycle, the XPSPVK module will stop the slide stroke and will also inhibit the start of another cycle.

Technical Data

Module Type		XPSPVK
Power Supply		
Voltage	V	24/115/230 Vac
Voltage limits		-15... +10% (24 Vdc), -15... +15% (115 Vac), -15... +10% (230 Vac)
Frequency	Hz	50/60
Power Consumption		
24 V	W	< 9
115 V/230 V	VA	< 16
Module Fuse Protection		≤ 4 A external fuse
Outputs		
Voltage Reference		Relay hard contacts
No. and nature of safety circuits		1 N.O. (13-14) transfer function, 1 N.C. (21-22) feedback loop.
No. and nature of additional circuits		4 solid-state
AC-15 Breaking capacity	VA	C300: inrush 1800, sealed 180
DC-13 Breaking capacity		24 V/1.5 A - L/R=50 ms (contact 13-14)
Max thermal current (Ithe)	A	2.5
Solid state output power		24 V/20 mA, 48V/10 mA
Output fuse protection	A	4 A fuse; per IEC 947-5-1, DIN VDE 0660 part 200
Minimum current	mA	10
Minimum voltage	V	17
Response Time	ms	<40
Electrical Life		See page 78
Rated Insulation Voltage (Ui)	V	300 (Pollution degree 2 per IEC 947-5-1, DIN VDE 0110 parts 1 and 2)
Rated Impulse Withstand Voltage (Uimp)	kV	4 (Overvoltage category III, per IEC 947-5-1, DIN VDE 0110 parts 1 and 2)
LED Display		8
Operating Temperature		+14 °F to +130 °F (-10 °C to +55 °C)
Storage Temperature		-13 °F to +185 °F (-25 °C to +85 °C)
Degree of Protection per IEC 529		
Terminals		IP20
Housing		IP40
Polycarbonate Enclosure		
Type		Plug-in terminal strip
Number of terminals		32
Connection Type		Captive screw-clamp terminals. Maximum wire size: 2-14 AWG (2 x 2.5 mm ²) without cable end, 2-16 AWG (2 x 1.5mm ²) with cable end, minimum diameter of 0.02 in (0.5 mm) or 24 AWG.

PREVENTA™ XPS Safety Relays Double-Body Solenoid Valve Monitoring

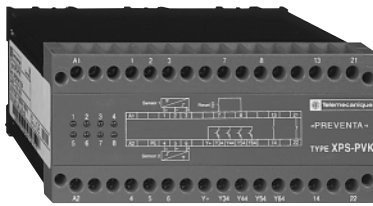

XPSVK

Ordering Information

Description	No. of Safety Circuits	Solid State Outputs for PLC	Power Supply	Catalog Number	Weight oz. (kg)
Safety modules for dynamic monitoring of double-bodied solenoid valves	1 N.O and 1 N.C.	4	24 Vdc	XPSPVK1184	25 (0.700)
			115 Vac	XPSPVK3484	32 (0.900)
			230 Vac	XPSPVK3784	32 (0.900)

Suitable for use in circuits through Category 4 per EN 954-1

XPSPVK

Press safety valve diagram and an XPSPVK module

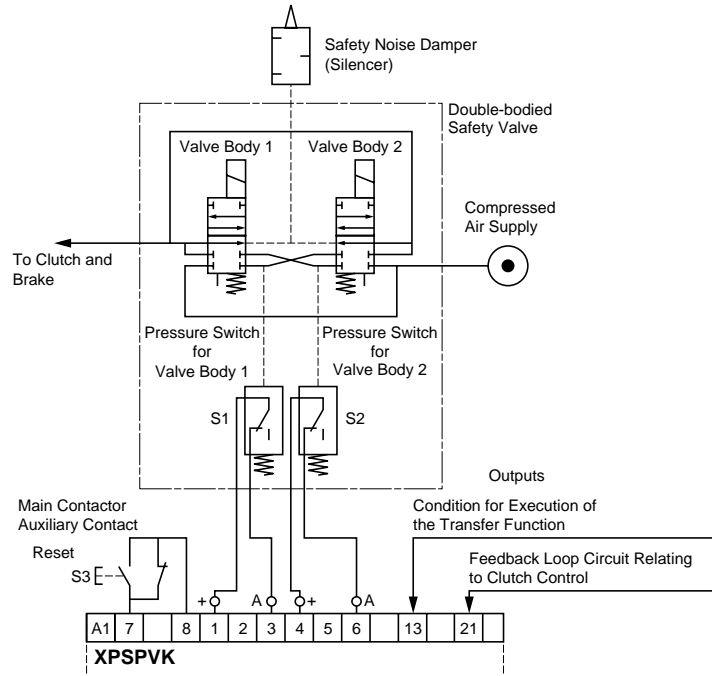

LED Signals

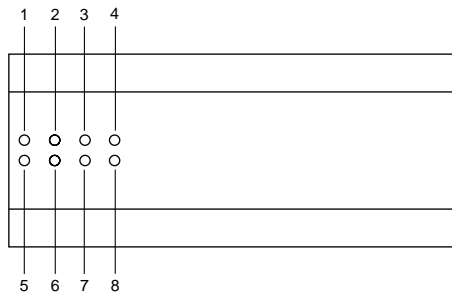

- 1 DC internal supply no. 1
- 2 DC internal supply no. 2
- 3 Valve no. 1 blocked
- 4 Valve no. 2 blocked
- 5 Ready for monitoring
- 6 Disconnect synchronised
- 7 Reset
- 8 Valves 1 and 2 energised

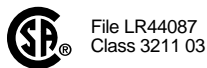

Dimensions 147-148

PREVENTA™ XPS Safety Relays

Double-Body Solenoid Valve Monitoring

XPSPVK Functional Diagram

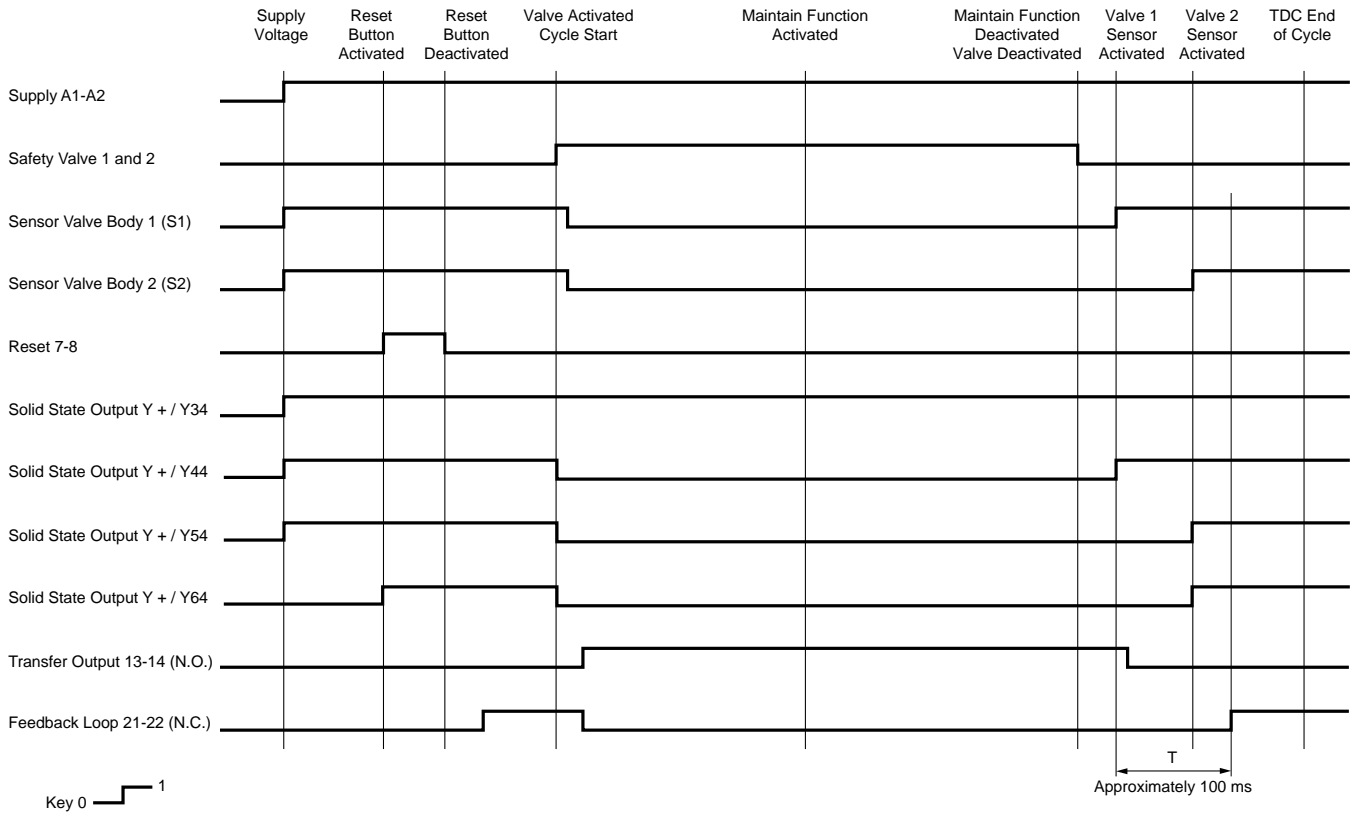

Wiring Diagrams and Connections

XPSPVK module with 3-wire (or 2-wire) proximity sensors

3 Wire Sensors

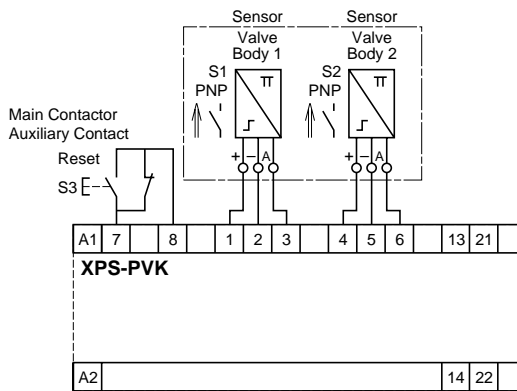

2 Wire Sensors

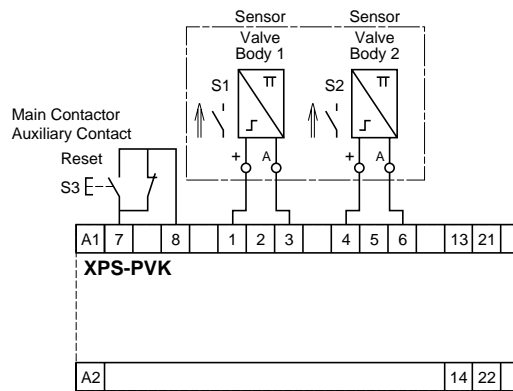

PREVENTA™ XPS Safety Relays Double-Body Solenoid Valve Monitoring

Wiring Diagrams and Connections

XPSPVK

XPSPVK module with an eccentric press safety valve

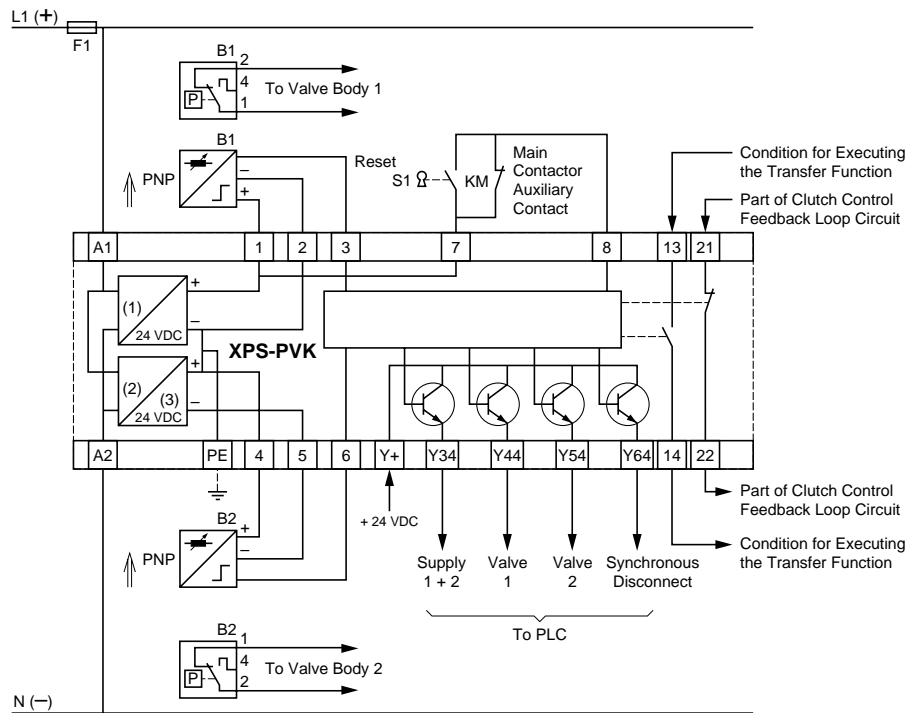

- (1) Internal power supply no. 1
- (2) Internal power supply no. 2
- (3) For a 24 VDC version: integrated -/- adapter

PREVENTA™ XPS Safety Relays

Stopping with Braking Distance Monitoring

Operating Principle

Safety module XPSOT is used on eccentric presses to monitor over-travel and ensure that the press slide stops in a non-hazardous position, that is, top dead center (TDC) during normal (non-emergency) operation. Use of this module, designed in accordance with standard EN 692 relating to mechanical press safety, makes it possible to create a redundant, self-monitoring control system.

The two essential functions of this safety module are :

- Trigger the end of cycle stop sequences slightly before TDC (at point A) so as to reach a standstill stop at TDC. After TDC, the acceptable overtravel is approximately 10°. The safety module immediately detects any over-travel. Over-travel is indicative of braking device deterioration. In this case, jog mode must be used to move the slide back to TDC. The next cycle will be inhibited to allow maintenance to be performed on the braking device (cam 1).
- Take over control monitoring during the hazardous part of the cycle (slide downstroke). Any stop instruction issued between TDC (0°) and point C (approximately 150° after TDC) causes an immediate stop of the press. This approximate value of 150° corresponds to the 0.315" (8 mm) tool closure dimension (safety point). When a stop instruction is issued after this point, the press completes the cycle and comes to a complete stop at TDC (cam 2).

Control of the hazardous part of the cycle (generally the slide downstroke) is usually achieved from a two-hand control station associated with safety module (type XPSBC) monitoring this station to qualify as a Category 4 control system according to standard EN 954-1. Over-travel monitoring is performed on **each cycle** by safety module XPSOT.

Press

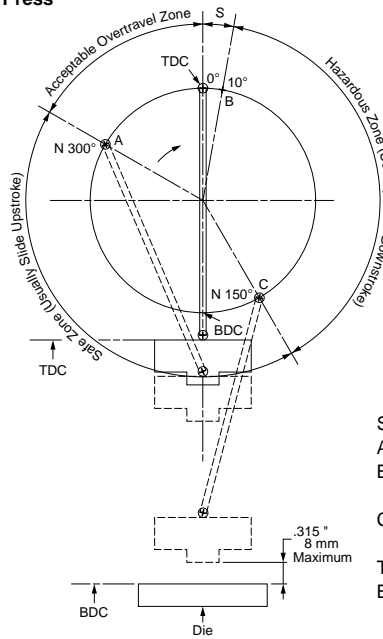

- S Acceptable overtravel
- A Stop instruction trip point
- B Point at which acceptable overtravel is exceeded (a stop instruction issued after point B will lock up the press)
- C Takeover point, beyond which the press will complete its cycle up to TDC
- TDC Top dead center, actual stopping zone
- BDC Bottom dead center

Control cams

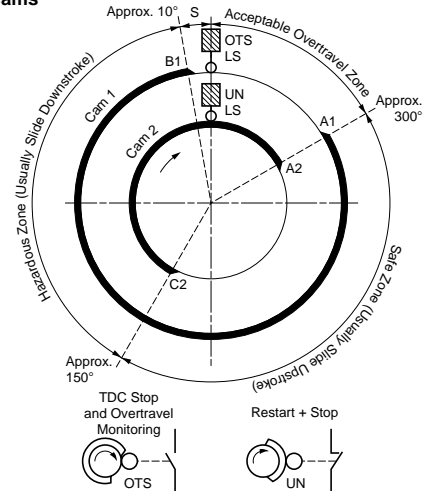

Cam Operation

Cam 1 is associated with the OTS limit switch (LS), cam 2 with the UN limit switch (the limit switches must be located on different cams for safety reasons).

The OTS limit switch is deactivated at TDC, at which point the UN limit switch is activated.

Point A1 of cam 1 is located approximately 300° from TDC and, when reached, the press comes to a standstill:

A1 is the press stop trigger point.

Point B1, located approximately 10° after TDC, constitutes the end of cam 1: **If B1 is exceeded during stopping**, the over-travel is abnormally long, the press **locks up and** the next cycle is inhibited.

Point A2 of cam 2 functions like point A1 on cam 1 (contact state of the UN limit switch reversed in relation to the contact state of the OTS limit switch).

Point C2, located approximately 150° after TDC, corresponds to the 0.315" (8 mm) tool closing dimension. Stop instructions issued after C2 is reached are not executed until point A2 is reached.

PREVENTA™ XPS Safety Relays Stopping with Braking Distance Monitoring

Technical Data

Module Type		XPSOT
Power Supply		
Voltage	V	115 Vac, 230 Vdc
Voltage limits		-15... +15% (115 Vac) -15... +10% (230 Vac)
Frequency	Hz	50/60
Power Consumption		
115 V/230 V	VA	< 12
Module Fuse Protection		≤ 4 A external fuse
Outputs		
Voltage Reference		Relay hard contacts
No. and nature of safety circuits		3 N.O. (11-12, 11-13, 11-14)
No. and nature of additional circuits		1 N.O. (11-44) + 1 N.C. (25-26) + 4 solid state
AC-15 Breaking capacity	VA	C300: inrush 1800, sealed 180
DC-13 Breaking capacity		24 V/1.5 A - L/R=50 ms
Solid-state output breaking capacity		24 V/20 mA, 48 V/10 mA
Max thermal current (Ithe)	A	2.5
Output fuse protection	A	4 A fuse; per IEC 947-5-1, DIN VDE 0660 part 200
Minimum current	mA	10
Minimum voltage	V	17
Response Time	ms	< 20
Electrical Life		See page 78
Rated Insulation Voltage (Ui)	V	300 (Pollution degree 2 per IEC 947-5-1, DIN VDE 0110 parts 1 and 2)
Rated Impulse Withstand Voltage (Uimp)	kV	4 (Overvoltage category III, per IEC 947-5-1, DIN VDE 0110 parts 1 and 2)
LED Display		4
Operating Temperature		+14 °F to +130 °F (-10 °C to +55 °C)
Storage Temperature		-13 °F to +185 °F (-25 °C to +85 °C)
Degree of Protection per IEC 529		
Terminals		IP20
Housing		IP40
Polycarbonate Enclosure		
Type		Plug-in terminal strip
Number of terminals		42
Connection Type		Captive screw-clamp terminals. Maximum wire size: 2-14 AWG (2 x 2.5 mm ²) without cable end, 2-16 AWG (2 x 1.5 mm ²) with cable end, minimum diameter of 0.02 in. (0.5 mm) or 24 AWG.

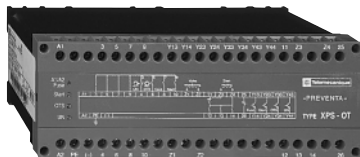

XPSOT



File E164353
CCN NKCR



File LR44087
Class 3211 03



Ordering Information

Description	No. of Safety Circuits	Solid State Outputs for PLC	Power Supply	Catalog Number	Weight oz. (kg)
Safety modules for stop with automatic over-travel monitoring and control	3 N.O	4	115 Vac	XPSOT3444	39 (1.100)
			230 Vac	XPSOT3744	39 (1.100)

Suitable for use in circuits through Category 4 per EN 954-1

Dimensions 147-148

PREVENTA™ XPS Safety Relays

Stopping with Braking Distance Monitoring

Wiring Diagrams and Connections

XPSOT

Example of a safety circuit connecting an XPSOT, two-hand control station, two-hand control safety relay XPSBC, press cam switches, safety valves, a double-body solenoid valve monitor XPSPVK, and a Programmable Controller.

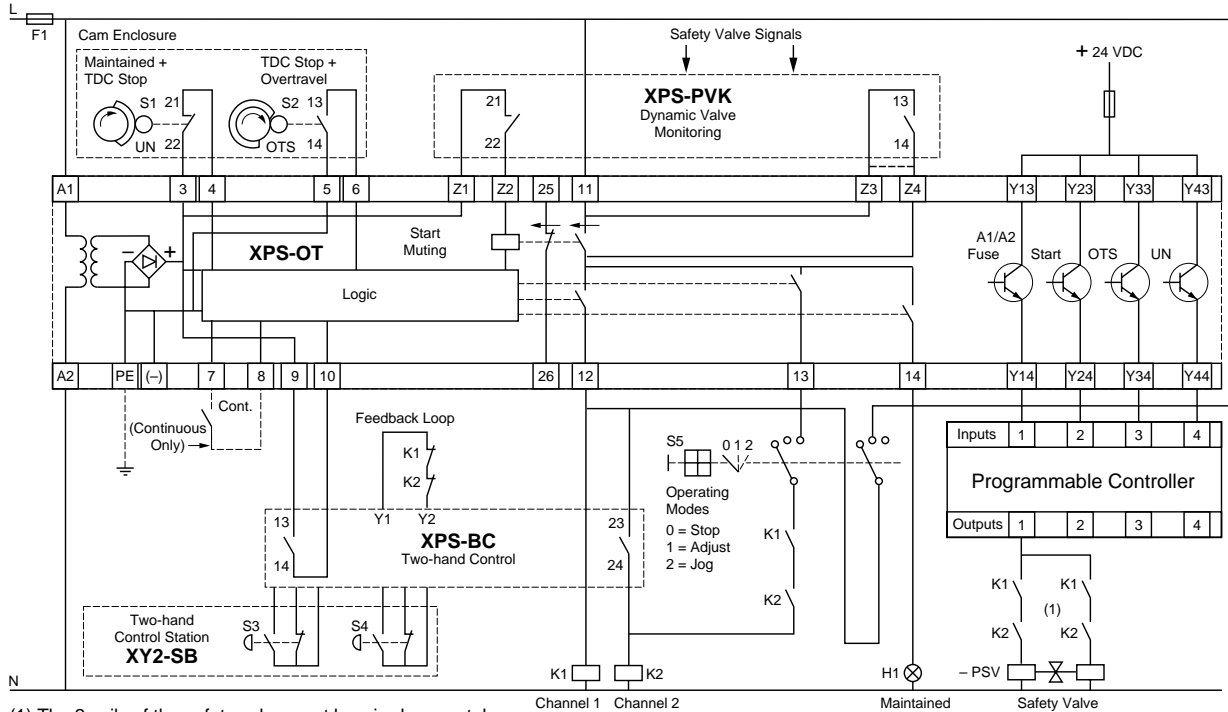

(1) The 2 coils of the safety valve must be wired separately.

XPSOT Functional Diagram

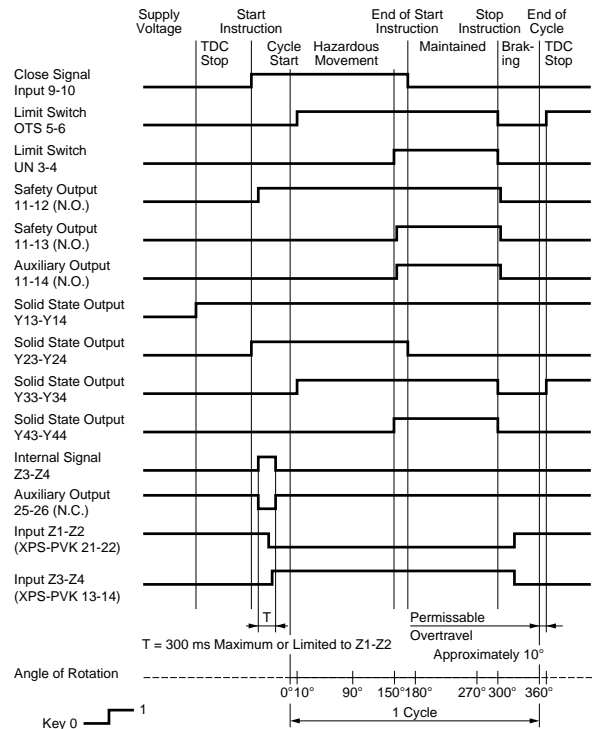

LED Signals

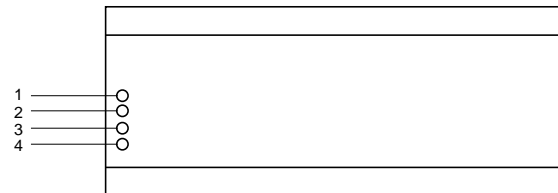

- 1 Voltage present on terminals A1/A2
- 2 Close instruction
- 3 OTS limit switch activated
- 4 UN limit switch activated

PREVENTA™ XPS Safety Relays Shaft or Chain Break Monitoring

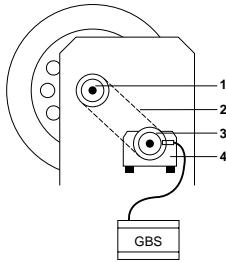

- 1 Eccentric shaft
- 2 Transmission chain
- 3 Gear wheel with proximity sensor
- 4 Cam transfer mechanism

Operating Principle

Used on mechanical and eccentric presses, this module monitors the transmission chain linking the two main shafts of the press: the eccentric shaft and the shaft supporting the cam transfer mechanism (cam shaft). The function of this module is to detect failures in the chain or cam shaft and to prevent the continuation of the cycle by initiating an emergency stop of the press.

This module is used only in cases where the cam transfer mechanism is located on a shaft other than the eccentric shaft.

Module input data is provided by a proximity sensor (2-wire, 3-wire NPN, or 3-wire PNP), mounted across from a gear wheel integrated on the cam shaft.

This sensor transmits pulses to the GBS module. The GBS module outputs are connected to contactors controlling the clutch/brake control valves:

- When the eccentric shaft is stopped, the GBS module receives no impulses, which causes the output relay to be energized.

- The output relay is de-energized when the press is restarted, and the contactors driving the clutch/brake valves assume auto-feed positions.
- If the transmission chain breaks, the press is placed into an emergency stop condition.

The GBS module provides continuous press monitoring for the entire cycle.

The user must calculate the exact number of pulses / minute (number of revolutions per minute multiplied by the number of teeth on the gear wheel).

The device is typically designed for rates between 500 and 6000 pulses / minute. If this is the case, select the following references: **GBS120VAC** or **GBS230VAC**.

If the rate is lower than 500 pulses / minute, indicate the exact rate on the order form. The module will be adapted specifically to this value. In this case, select the following catalog numbers: **GBS120VAC INF** or **GBS230VAC INF**.

Technical Data

Module Type		GBS
Power Supply		
Voltage	V	120/230 Vac
Voltage Limits		-10...+6 % (120, 230 V)
Frequency	Hz	50/60 (120 V), 50 (230 V)
Power Consumption	VA	< 8
Inputs		
Proximity Sensor Voltage	V	24 Vac/dc
Switch Point Hysteresis		< 10 % of the number of pulses / minute
Adjustment Precision		± 10 % of the selected number of pulses / minute
Outputs		
Voltage Reference		Relay hard contacts
No. and nature of safety circuits		2 N.O. (23-24, 43-44) + 2 N.C. (11-12, 31-32)
No. and nature of additional circuits		–
AC-15 Breaking capacity	VA	B300: inrush 3600, sealed 360
DC-13 Breaking capacity		24 V/4 A - L/R = 50 ms
Max thermal current (Ithe)	A	5
Output fuse protection	A	6 A fuse; per IEC 947-5-1, VDE 0660 part 200
Minimum current	mA	10
Minimum voltage	V	17
Electrical Life		See Page78
Response Time	ms	< 300
Rated Insulation Voltage (Ui)	V	300 (Pollution degree 2 per IEC 947-5-1, DIN VDE 0110 Parts 1 and 2)
Rated Impulse Withstand Voltage (Uimp.)	kV	4 (Overvoltage category III, per IEC 947-1, DIN VDE 0110 Parts 1 and 2)
LED Display		1
Operating Temperature		+ 14 °F to + 130 °F (- 10 °C to + 55 °C)
Storage Temperature		- 13 °F to + 185 °F (- 25 °C to + 85 °C)
Degree of Protection per IEC 529		
Terminals		IP 10
Housing		IP 40
Polycarbonate Housing		
Type		Non-plug-in
No. terminals		20
Connection		
Type		Captive screw-clamp terminals. Maximum wire size: 2-14 AWG (2 x 2.5 mm ²) without cable end, 2-16 AWG (2 x 1.5 mm ²) with cable end, minimum diameter of 0.02 in. (0.5 mm) (24 AWG)

PREVENTA™ XPS Safety Relays Shaft or Chain Break Monitoring

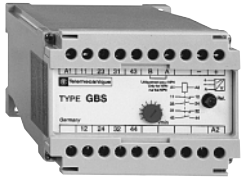

GBS

Ordering Information

Description	Pulses /minute	Display	Power Supply	Catalog Number	Weight oz. (kg)
Safety modules for shaft and chain monitoring 	> 500	1 LED	120 Vac	GBS120VAC	18 (0.500)
			230 Vac	GBS230VAC	18 (0.500)
	< 500	1 LED	120 Vac	GBS120VAC INF	18 (0.500)
			230 Vac	GBS230VAC INF	18 (0.500)

Wiring Diagrams

GBS

Configuration of the GBS module and proximity sensors

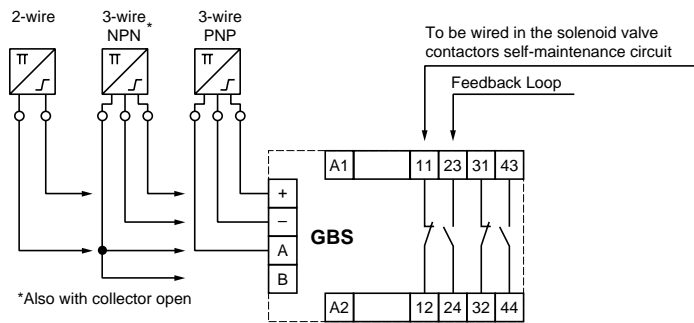

GBS Functional Diagram

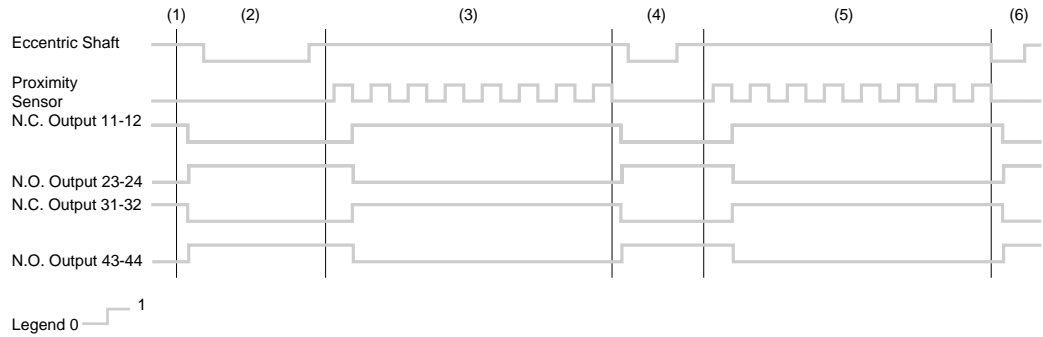

- (1) Input voltage ON
- (2) Eccentric shaft stopped
- (3) Eccentric shaft in motion
- (4) Eccentric shaft stopped
- (5) Eccentric shaft in motion
- (6) Eccentric shaft stopped

OPERATING PRINCIPLE

The XPSNS module is designed for reliable detection and amplification of signals generated by:

- 24 Vdc proximity sensors (2-wire, 3-wire NPN, or 3-wire PNP types),
- magnetic sensors,
- limit switches.

The amplifier generates output signals which can be used in mechanically linked contact relays in safety circuits.

Applications include: solenoid valve proximity sensors for eccentric press clutch/brake functions, magnetic sensors, or limit switches mounted on protective guards, etc.

By applying a nominal voltage to terminals A1/A2, two separate 24 Vdc supplies are generated, terminals A+ = (+) / A- = (-) and terminals B+ = (+) / B- = (-), the latter being interconnected such that an internal short-circuit is generated if the proximity sensors are improperly connected. In turn, the short-circuits, are displayed by the corresponding LED "POWER SUPPLY 1" or "POWER SUPPLY 2".

Two other LEDs indicate the status of their corresponding proximity sensor.

Each output relay (linked contacts) contains a N.O. hard contact and a N.C. hard contact. A monitoring circuit connected to terminals 51-52 comprises 2 N.C. contacts in series for each of the two output relays. Possible sensor or limit switch connections and their combinations are shown in the electrical connections diagram on page 146.

Note: If S1 and S2 are two proximity sensors placed close to each other, two different types of sensor should be used to avoid interference.

For example:

S1: 2-wire,

S2: 3-wire NPN.

Module Type		XPSNS
Power Supply		
Voltage	V	115/230 Vac
Voltage limits		-15... +15% (115 Vac) -15... +10% (230 Vac)
Frequency	Hz	50/60
Module Fuse Protection		≤ 4 A external fuse
Power Consumption 115 V/230 V	VA	< 8
Outputs		
Voltage Reference		Relay hard contacts
No. and nature of safety circuits		2 N.O. (13-14, 43-44), 2 N.C. (21-22, 31-32)
No. and nature of additional circuits		1 N.C. (51-52)
AC-15 Breaking capacity	VA	C300: inrush 1800, sealed 180
DC-13 Breaking capacity		24 V/1.5 A - L/R=50 ms
Breaking capacity of solid state outputs		24 V/20 mA, 48 V / 10 mA
Max thermal current (I _{the})	A	2.5
Output fuse protection	A	4 A fuse; per IEC 947-5-1, DIN VDE 0660 part 200
Minimum current	mA	10
Minimum voltage	V	17
Electrical Life		See page 78
Rated Insulation Voltage (U_i)	V	300 (Pollution degree 2 per IEC 947-5-1, DIN VDE 0110 parts 1 and 2)
Rated Impulse Withstand Voltage (U_{imp})	kV	4 (Overvoltage category III, per IEC 947-5-1, DIN VDE 0110 parts 1 and 2)
LED Display		4
Operating Temperature		+14 °F to +130 °F (-10 °C to +55 °C)
Storage Temperature		-13 °F to +185 °F (-25 °C to +85 °C)
Degree of Protection per IEC 529		
Terminals		IP10
Housing		IP40
Connection Type		Captive screw-clamp terminals. Maximum wire size: 2-14 AWG (2 x 2.5 mm ²) without cable end, 2-16 AWG (2 x 1.5 mm ²) with cable end, minimum diameter of 0.02 in. (0.5 mm) or 24 AWG.

PREVENTA™ XPS Safety Relays

Safety Amplifier Relay

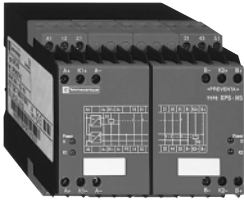

Ordering Information

Description	No. of Safety Circuits	Power Supply	Catalog Number	Weight oz. (kg)
Safety modules for amplifier relay applications	2 N.O. and 2 N.C.	115 Vac	XPSNS3440	28 (0.800)
		230 Vac	XPSNS3740	28 (0.800)

Suitable for use in circuits through Category 4 per EN 954-1

Wiring Diagrams and Connections

XPSNS

XPSNS modules with sensors

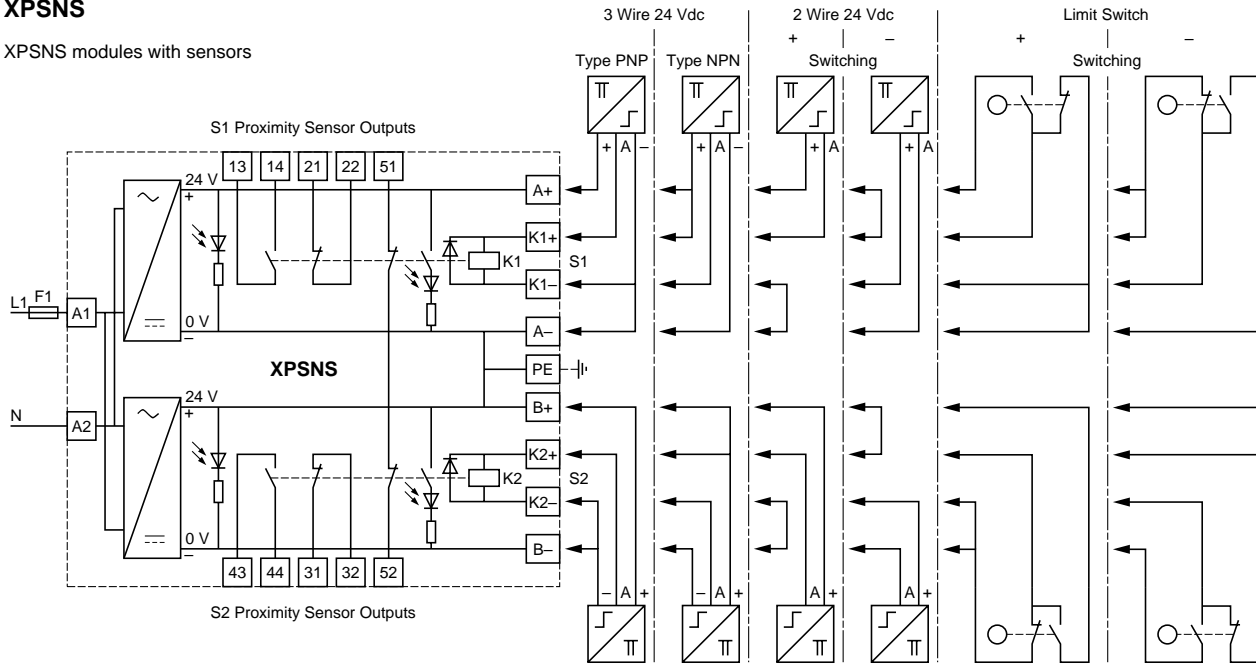

XPSNS Functional Diagram

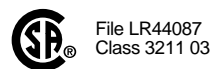
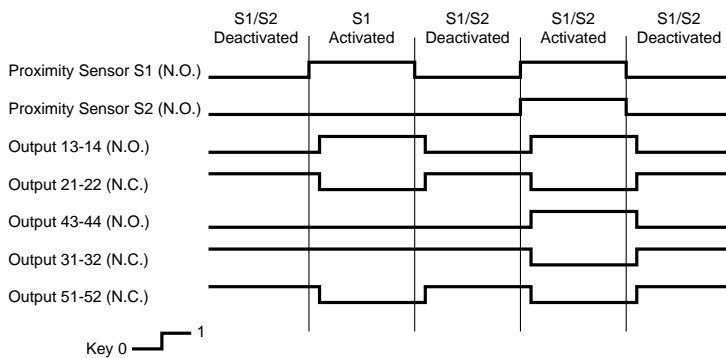

PREVENTA™ XPS Safety Relays Dimensions and Mounting

XPSAL, XPSAX, XPSBA

AM1-DP200 Rail Mounting

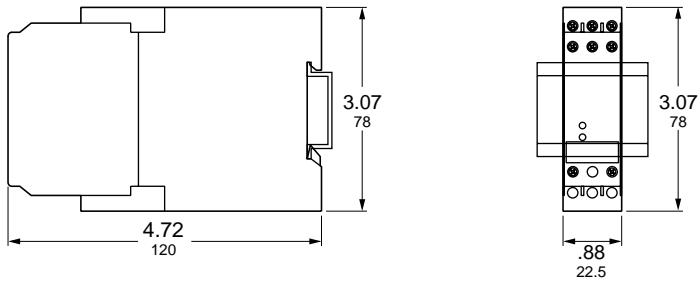

XPSAM, XPSAMF, XPSAP, XPSAPF, XPSAT, XPSECM, XPSECP, XPSFB, XPSNS, XPSVN

AM1-DP200 Rail Mounting

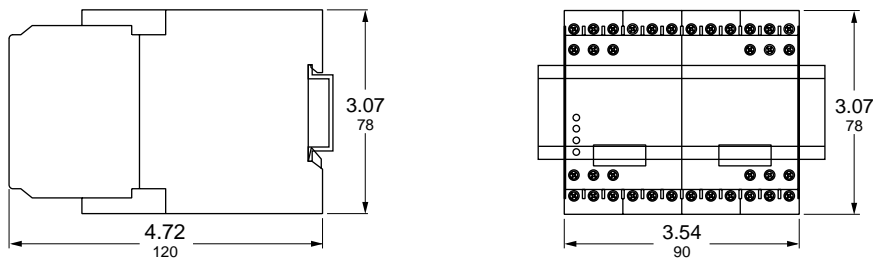

XPSAS, XPSASF, XPSBC, XPSCE, XPSDA

AM1-DP200 Rail Mounting

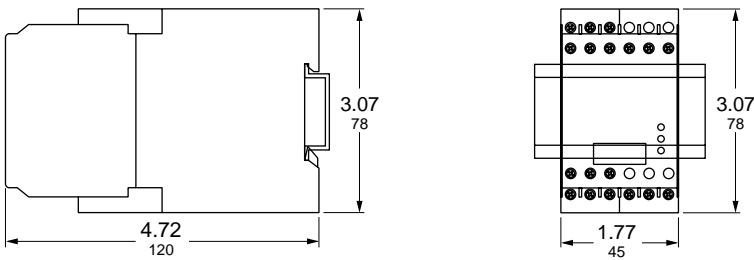

GNKL, XPSPVT

AM1-DP200 Rail Mounting

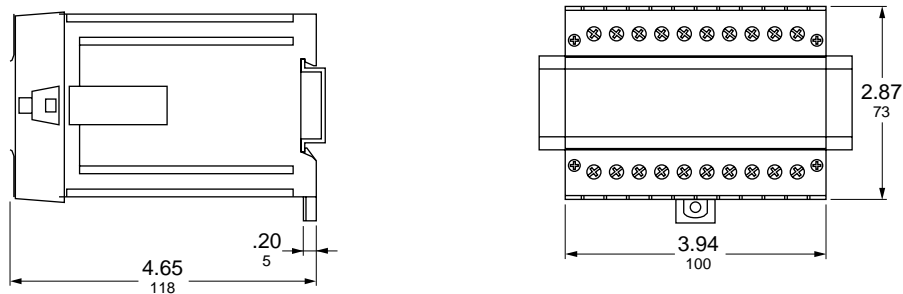

PREVENTA™ XPS Safety Relays

Dimensions and Mounting

GBS

AM1-DP200 Rail Mounting

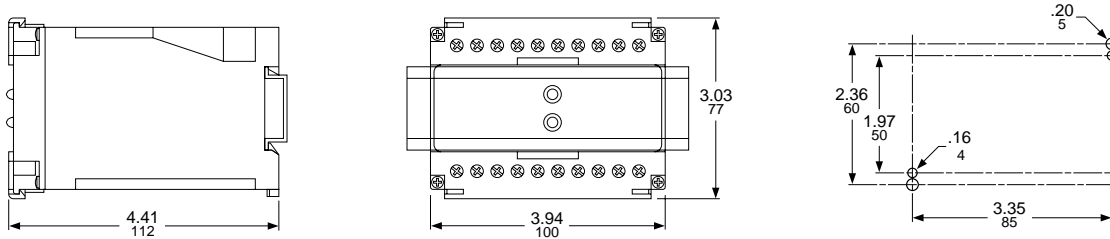

XPSPVK

AM1-DP200 Rail Mounting

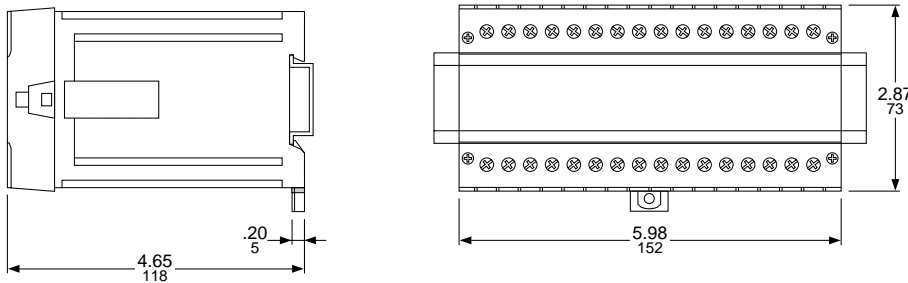

XPSOT

AM1-DP200 Rail Mounting

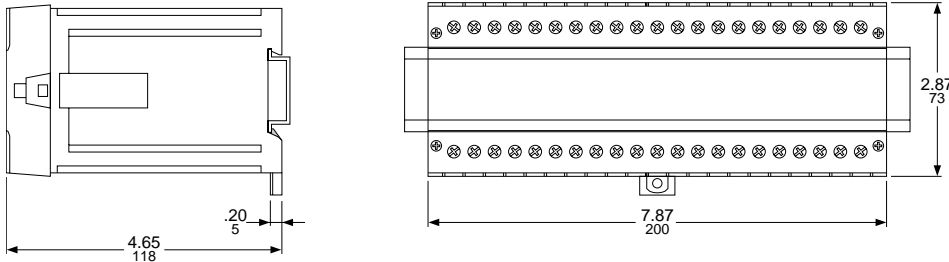

Dimensions

XU2-S18•P340L5, XU2-S18•P340L5L

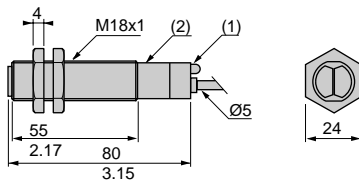

- (1) LED
- (2) Potentiometer

XU2-S18•P340D

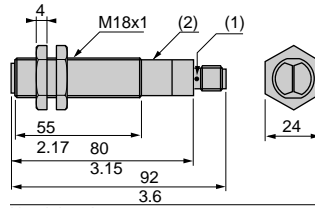

- Nut tightening torque: 33 lb-ft (24 N•m)
- Connector tightening: 2.7 lb-ft (2 N•m)

XU2-S18•P340DL

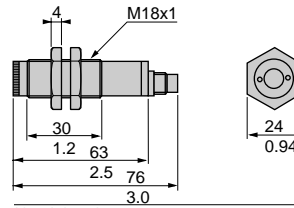

- Nut tightening torque: 5.4 lb-ft (4 N•m)
- Connector tightening torque: 2.7 lb-ft (2 N•m)

XU2-S18•P340WL5

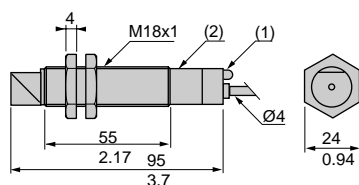

- (1) LED
- (2) Potentiometer

XU2-S18•P340WD

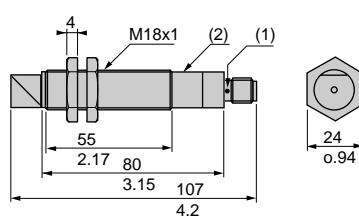

- Nut tightening torque: 33 lb-ft (24 N•m)
- Connector tightening torque: 2.7 lb. ft. (2 N•m)