

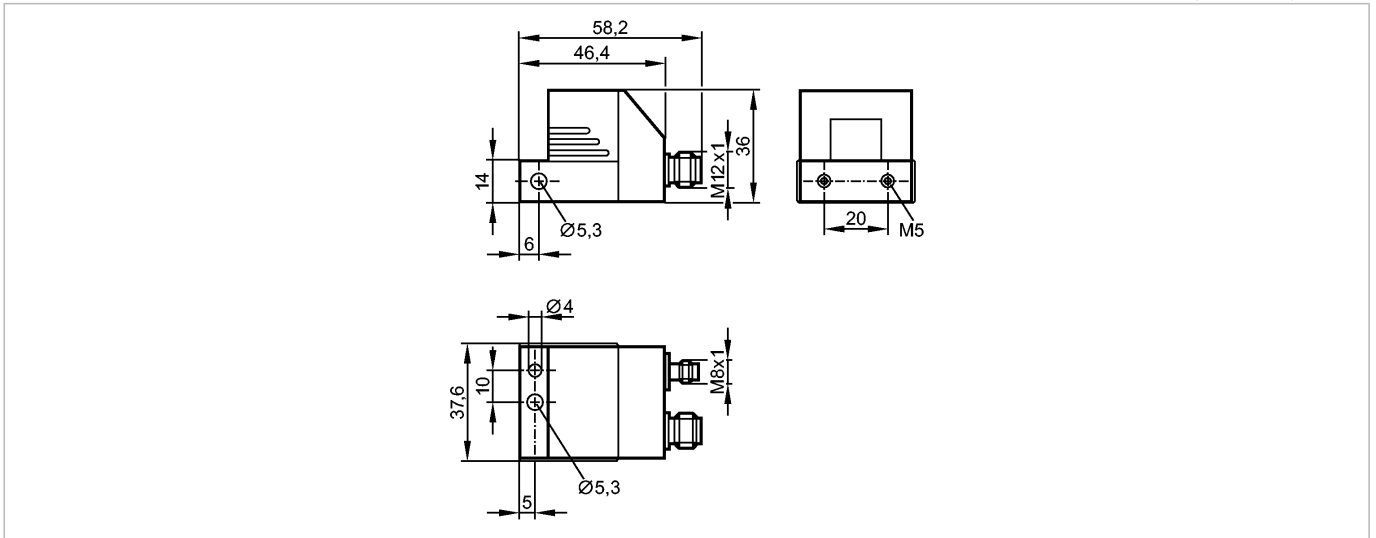

VIBRATION DIAGNOSTIC UNIT ATEX

Diagnostic systems



Product characteristics

Vibration diagnostic unit

Connection via M12 x 1 and M8 x 1 connectors

ATEX approval

Group II, category 3G

Group II, category 3D

Spectral analysis / FFT

Envelope-curve FFT

Trend analysis

Application

Application Up to 20 frequencies in the spectrum, freely selectable, diagnostic level adjustable

Electrical data

Electrical design

DC PNP

Operating voltage [V]

10...32 DC

Current consumption [mA]

100 (24 V) plus optional external pulse pick-up

Protection class

III

Measuring / setting range

value range [g]

± 25 \*\*)

Environment

Ambient temperature [°C]

-20...60

Protection

IP 69K

Tests / approvals

Marking of the unit

⊕ II 3D Ex tD A22 IP69K T = 90°C X -20°C ≤ Ta ≤ 60°C

⊕ II 3G Ex nA II T4 X

EMC

EN 61000-4-2 ESD: 4 kV CD / 8 kV AD

EN 61000-4-3 HF radiated: 10 V/m

EN 61000-4-4 Burst: 2 kV

EN 61000-4-6 HF conducted: 10 V

Mechanical data

Housing materials

housing: diecast zinc

Overload protection [g]

100

Weight [kg]

0.247

Electrical connection

Connection

M12 connector; M8 connector

**Wiring**

**VE112A - Vibration diagnostic unit - eclass: 27201406 / 27-20-14-06**

Plug M8 (RS485 communication)



Pin 1: -  
Pin 2: B  
Pin 3: -  
Pin 4: A

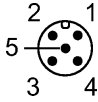

M12 connector (electrical connection)  
Pin 1: supply +  
Pin 2: red function; switching output 2 / 100 mA / NO/NC programmable  
Pin 3: supply -  
Pin 4: yellow function; switching output 1 / 100 mA / NO/NC programmable  
Pin 5: rotational speed, 0...20 mA or pulse input

Remarks

Remarks

\*\* ) nominal  $\pm 20$   
Pin 2 (switching output 2) and pin 4 (switching output 1) can only be programmed in pairs

Pack quantity [piece]

1

Other data

Sensing principle

micromechanical accelerometer / capacitive measuring principle / one measurement axis

Minimum measuring time [s]

8

Frequency range [Hz]

0.125...500

Spectral resolution [Hz]

0.125

Speed range [rpm]

12...1500 (the actual rotational speed range depends on the type of the rolling element bearing and can therefore differ)