

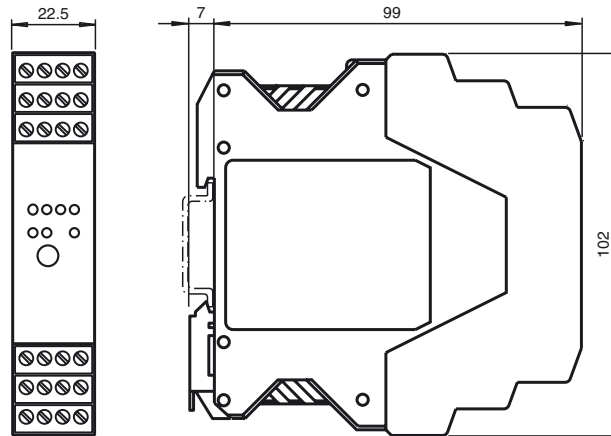

Dimensions



Electrical connection

Model number

VBA-4E-KE-ZE0

KE switch cabinet module
4 inputs (NPN)

Features

- A/B slave with extended addressing possibility for up to 62 slaves
- Housing with removable and color coded terminals
- Communication monitoring
- Inputs for 2- and 3-wire sensors
- Addressing jack
- Supply of inputs external or from the module, as required
- Function display for bus, internal input supply and inputs

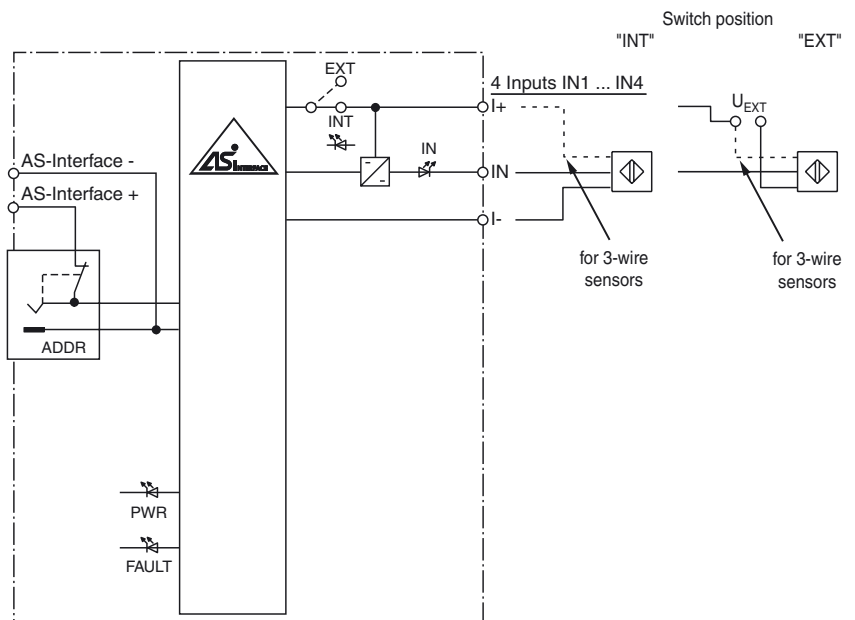

Indicating / Operating means

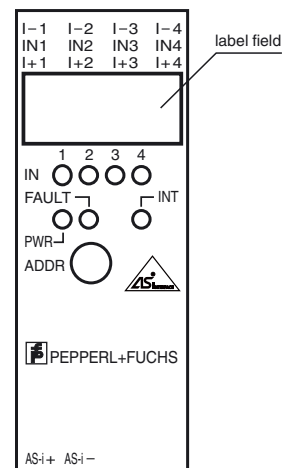
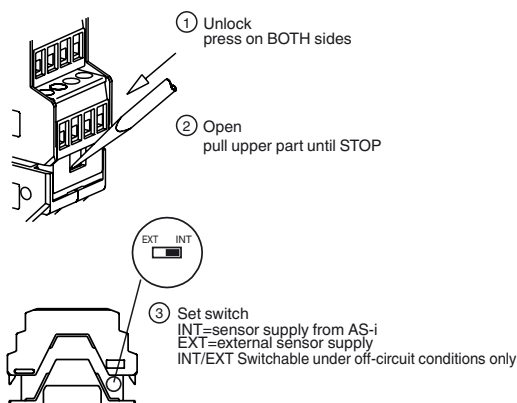

Release date: 2016-09-08 13:29 Date of issue: 2016-09-08 119165_eng.xml

Refer to "General Notes Relating to Pepperl+Fuchs Product Information".

Pepperl+Fuchs Group
www.pepperl-fuchs.com

USA: +1 330 486 0001
fa-info@us.pepperl-fuchs.com

Germany: +49 621 776 4411
fa-info@de.pepperl-fuchs.com

Singapore: +65 6779 9091
fa-info@sg.pepperl-fuchs.com

Technical data**General specifications**

Slave type	A/B slave
AS-Interface specification	V2.1
Required master specification	≥ V2.0
UL File Number	E87056

Functional safety related parameters

MTTF _d	650 a
Mission Time (T _M)	20 a
Diagnostic Coverage (DC)	0 %

Indicators/operating means

LED FAULT	Fault display; Red LED red: Communication fault or address is 0 red, flashing: Overload, internal input supply
LED INT	Internal input supply active; LED green
LED PWR	AS-Interface voltage; LED green
LED IN	switching state (input); 4 LED yellow

Electrical specifications

Auxiliary voltage (input)	U _{EXT}	12 ... 30 V DC PELV
Rated operating voltage	U _e	26.5 ... 31.6 V from AS-Interface
Rated operating current	I _e	≤ 30 mA (without sensors) / max. 180 mA
Protection class		III
Surge protection	U _{EXT} , U _e	Over voltage category III, safe isolated power supplies (PELV)

Input

Number/Type	4 inputs for 2- or 3-wire sensors (NPN), DC
Supply	from AS-Interface (switch position INT, default settings) or external U _{EXT} (switch position EXT)
Voltage	21 ... 31 V DC (INT)
Current loading capacity	≤ 150 mA, overload- and short-circuit protected (INT)
Input current	≤ 8 mA (limited internally)
Switching point	according to DIN EN 61131-2 (Type 2)
0 (unattenuated)	≤ 2 mA
1 (attenuated)	≥ 4 mA
Signal delay	< 2 ms (input/AS-Interface)
Signal frequency	≤ 250 Hz

Programming instructions

Profile	S-0.A.0
IO code	0
ID code	A
ID1 code	7
ID2 code	0

Data bits (function via AS-Interface)

Data bits	Input
D0	IN1
D1	IN2
D2	IN3
D3	IN4

Parameter bits (programmable via AS-i)

Parameter bits	function
P0	not used
P1	not used
P2	not used
P3	not used

Ambient conditions

Ambient temperature	-25 ... 60 °C (-13 ... 140 °F)
Storage temperature	-25 ... 85 °C (-13 ... 185 °F)
Relative humidity	90 % , noncondensing
Pollution degree	2

Mechanical specifications

Degree of protection	IP20 according to EN 60529
Connection	removable terminals rated connection capacity: rigid/flexible (with and without wire-end ferrules): 0.25 mm ² ... 2.5 mm ² for multiple-wire connection with two wires of equal cross-section: flexible with twin wire-end ferrules: 0.5 mm ² ... 1.5 mm ²
Material	
Housing	PA 66-FR
Mass	150 g
Mounting	DIN mounting rail

Compliance with standards and directives

Directive conformity	
EMC Directive 2004/108/EC	EN 61000-6-2:2005, EN 61000-6-4:2007, EN 50295:1999
Standard conformity	
Noise immunity	EN 61000-6-2:2005

Function

The VBA-4E-KE-ZE0 AS-Interface coupling module is a cabinet module with 4 inputs. The housing, only 22.5 mm in width, takes up little place in the switch cabinet. The module is mounted by snapping onto the 35 mm DIN rail in accordance with EN 50022.

It can be connected by plug-in terminals. 4-way terminal blocks (black) are used for the inputs. The AS-Interface is connected via a double terminal block (yellow). This allows simple disconnection of single actuators or supply by commissioning or service. Either the module (from the AS-Interface) or an external power source are used to supply power to the inputs and the connected sensors. One switch in the device is used for switching. The selection of the internal input power supply is displayed on the INT LED. An LED on the front control plate is used to display the current switching state for each input.

Note:

An overload of the internal input supply is reported by the 'periphery error' to the AS-Interface master. Communication over the AS-Interface remains in effect.

Accessories**VBP-HH1-V3.0-KIT**

AS-Interface Handheld with accessory

VBP-HH1-V3.0

AS-Interface Handheld

VAZ-PK-1,5M-V1-G

Adapter cable module/hand-held programming device

Emitted interference	EN 61000-6-4:2007
AS-Interface	EN 50295:1999
Input	EN 61131-2:2004
Degree of protection	EN 60529:2000

Notes

Do not connect inputs and outputs, which are supplied via the module from AS-interface or via auxiliary power, with power supply and signal circuits with external potentials.