

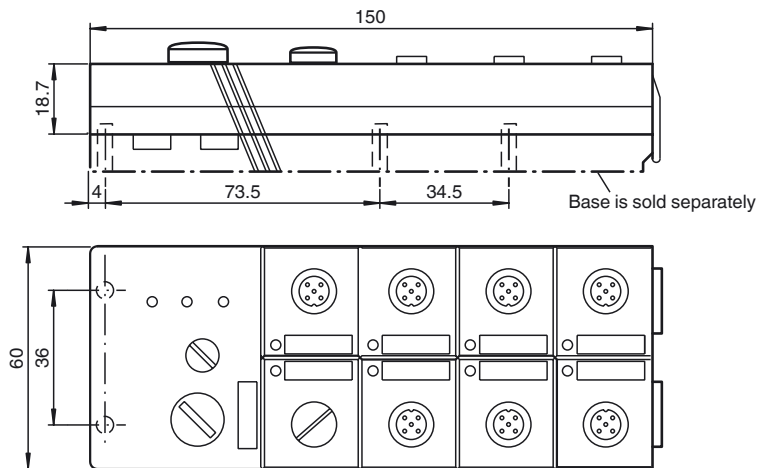

**Dimensions**

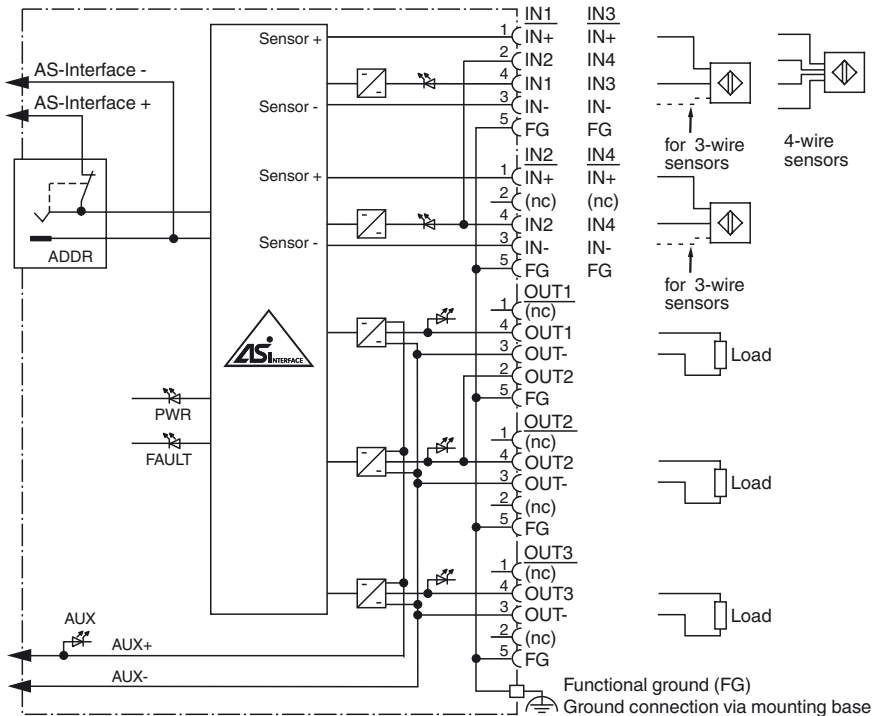

**Electrical connection**



**Model number**

**VBA-4E3A-G2-ZA/EA2**

G2 flat module  
4 inputs (PNP) and 3 electronic outputs

**Features**

- AS-Interface certificate
- Degree of protection IP67
- A/B slave with extended addressing possibility for up to 62 slaves
- Addressing jack
- Flat cable connection with cable piercing technique, variable flat cable guide
- Communication monitoring
- Inputs for 2-, 3-, and 4-wire sensors
- Power supply of outputs from the external auxiliary voltage
- Supply for inputs from AS-Interface
- Ground connection (FE) possible
- Function display for bus, ext. auxiliary voltage, inputs and outputs
- Detection of overload on sensor supply
- Detection of output overload

**Indicating / Operating means**

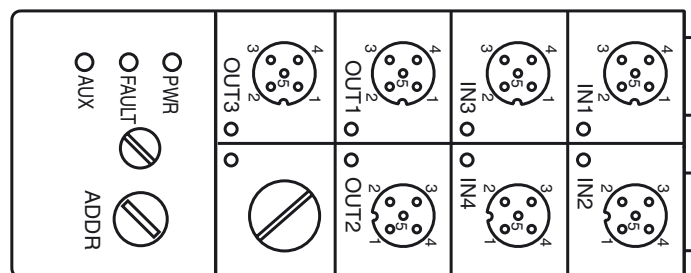

Release date: 2015-10-14 09:20 Date of issue: 2016-07-11 212523\_eng.xml

**Technical data****General specifications**

Slave type	A/B slave
AS-Interface specification	V3.0
Required master specification	≥ V2.1
UL File Number	E223772

**Functional safety related parameters**

MTTF <sub>d</sub>	140 a
Mission Time (T <sub>M</sub> )	20 a
Diagnostic Coverage (DC)	0 %

**Indicators/operating means**

LED FAULT	error display; LED red red: communication error or address is 0 red flashing: overload of sensor power supply or outputs
LED PWR	AS-Interface voltage; LED green
LED AUX	ext. auxiliary voltage U <sub>AUX</sub> ; LED green
LED IN	switching state (input); 4 LED yellow
LED OUT	Switching state (output); 3 LED yellow

**Electrical specifications**

Auxiliary voltage (output)	U <sub>AUX</sub>	20 ... 30 V DC PELV (protection class 3 according to VDE 0106/IEC 364-4-41)
Rated operating voltage	U <sub>e</sub>	26.5 ... 31.6 V from AS-Interface
Rated operating current	I <sub>e</sub>	≤ 40 mA (without sensors) / max. 240 mA
Protection class		III
Surge protection		U <sub>AUX</sub> , U <sub>in</sub> : Over voltage category III, safe isolated power supplies (PELV)

**Input**

Number/Type	4 inputs for 2- or 3-wire sensors (PNP), DC option 2 inputs for 4-wire sensors (PNP), DC
Supply	from AS-Interface
Voltage	21 ... 31 V
Current loading capacity	≤ 200 mA (T <sub>B</sub> ≤ 40 °C), ≤ 150 mA (T <sub>B</sub> ≤ 60 °C), overload-proof and short-circuit protected
Input current	≤ 9 mA (limited internally)
Switching point	according to DIN EN 61131-2 (Type 2)
0 (unattenuated)	≤ 3 mA
1 (attenuated)	≥ 5 mA

**Output**

Number/Type	3 electronic outputs, PNP, overload and short-circuit proof
Supply	from external auxiliary voltage U <sub>AUX</sub>
Current	4 A total, OUT 1, OUT 2: 2 A per output, OUT 3: 1.5 A
Voltage	≥ (U <sub>AUX</sub> - 0.5 V)

**Programming instructions**

Profile	S-7.A.2
IO code	7
ID code	A
ID1 code	7
ID2 code	2

Data bits (function via AS-Interface)	input	output
D0	IN1	OUT1
D1	IN2	OUT2
D2	IN3	OUT3
D3	IN4	-

**Parameter bits (programmable via AS-i) function**

P0	Communication monitoring P0 = 0 monitoring = off, the outputs maintain the status if communication fails P0 = 1 monitoring = on, i.e. if communication fails, the outputs are deenergised (default settings)
P1	Input filter P1 = 0 input filter on, pulse suppression ≤ 2 ms P1 = 1 input filter off (default settings)
P2	Synchronous mode P2 = 0 synchronous mode on P2 = 1 synchronous mode off (default settings)
P3	not used

**Ambient conditions**

Ambient temperature	-25 ... 60 °C (-13 ... 140 °F)
Storage temperature	-25 ... 85 °C (-13 ... 185 °F)
Relative humidity	85 % , noncondensing
Climatic conditions	For indoor use only
Altitude	≤ 2000 m above MSL
Pollution degree	3

**Mechanical specifications**

Degree of protection	IP67
----------------------	------

**Function**

The VBA-4E3A-G2-ZA/EA2 is an AS-Interface module with 4 Inputs and 3 outputs. Mechanical contacts (e. g. push buttons) as well as 2-, 3- and 4-wire sensors can be connected to the inputs. The outputs are electronic outputs, which can be collectively loaded with 24 V DC and 2 A or 1.5 A per output.

The IP67 flat module is ideal for applications in the field. An addressing jack is integrated in the module.

The connection for the sensors/actuators is via M12 x 1 screw connections. An LED is provided on the top of the module, for each channel, to indicate the current switching status. Similarly, an LED is provided to monitor the AS-Interface communication and to indicate that the module has the address 0. LEDs are also provided to indicate AS-Interface voltage and external power supply.

The mounting plate U-G2FF is used as standard for the connection to the AS-Interface flat cable and the external 24 V DC supply. The specially designed base enables the user to connect flat cable from both sides.

The device incorporates communication monitoring, which switches off power to the outputs if no communication has taken place on the AS-Interface line for longer than 40 ms.

An overloading of the internal input supply or of the outputs is signalled to the AS-interface master via the "Peripheral fault" function. Communication via the AS-Interface remains intact.

**Note:**

The mounting base for the module is sold separately.

**Accessories****VBP-HH1-V3.0-KIT**

AS-Interface Handheld with accessory

**VBP-HH1-V3.0**

AS-Interface Handheld

**VAZ-PK-1,5M-V1-G**

Adapter cable module/hand-held programming device

**VAZ-FK-ED-G2**

AS-Interface end seal for G2 modules

**Matching system components****U-G2FF**

AS-Interface module mounting base for connection to flat cable (AS-Interface and external auxiliary power)

Connection	Cable piercing method flat cable yellow/flat cable black inputs/outputs: M12 round connector
------------	--

**Material**

Housing	PBT
Mass	150 g
Tightening torque, cable gland	0.4 Nm
Mounting	Mounting plate

**Compliance with standards and directives**

## Directive conformity

EMC Directive 2004/108/EC	EN 61000-6-2:2001, EN 61000-6-4:2001, EN 50295:1999
---------------------------	---

## Standard conformity

Noise immunity	EN 61000-6-2:2001
Emitted interference	EN 61000-6-4:2001
Input	EN 61131-2:2007
Degree of protection	EN 60529:2000
Fieldbus standard	EN 50295:1999, IEC 62026-2:2006

**Notes**

For 4-wire sensors, it is only possible to use plug-in slot IN1 or IN3 for inputs 1+2 or 3+4 (jumped internally).

Do not connect inputs and outputs, which are supplied via the module from AS-interface or via auxiliary power, with power supply and signal circuits with external potentials.