

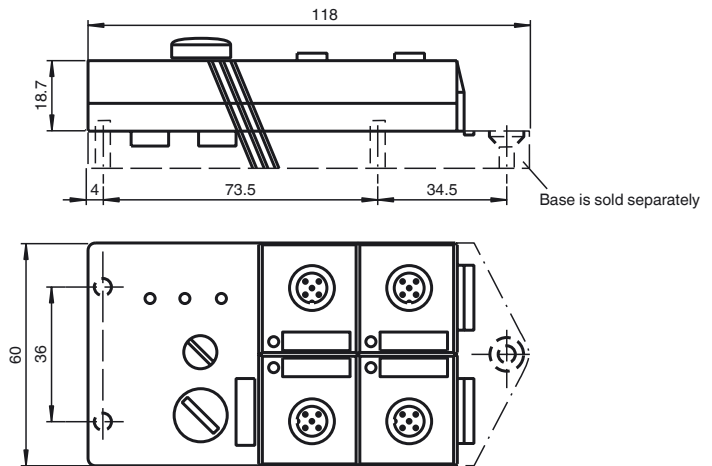

Dimensions

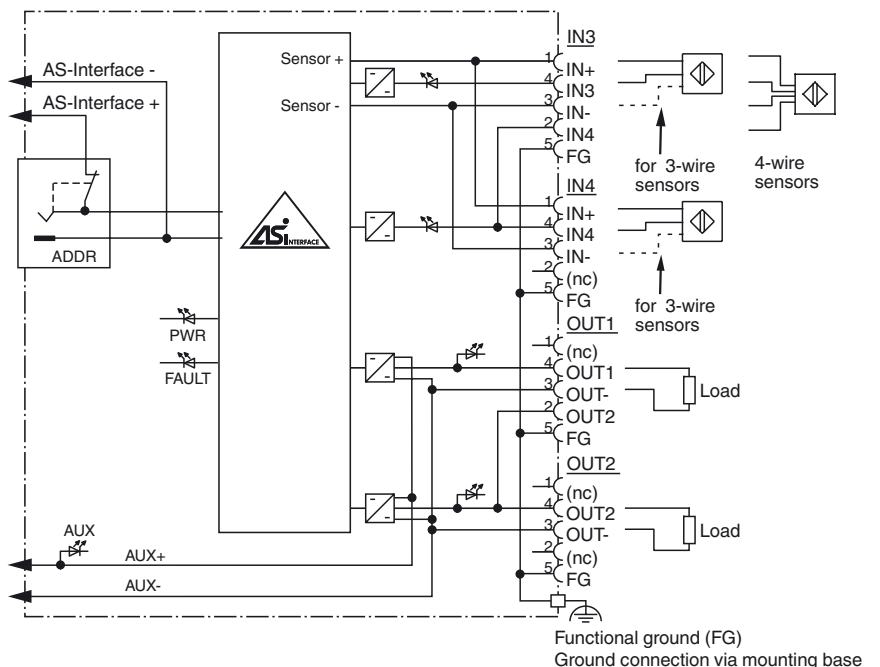

Electrical connection



Indicating / Operating means

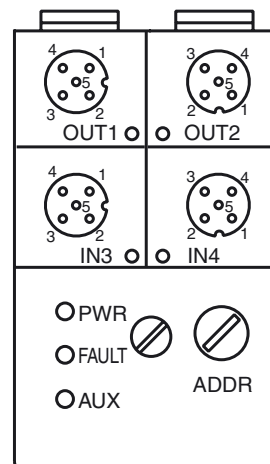

Model number

VBA-2E2A-G2-ZA/EA2

G2 flat module
2 inputs (PNP) and 2 electronic outputs

Features

- AS-Interface certificate
- Degree of protection IP67
- A/B slave with extended addressing possibility for up to 62 slaves
- Addressing jack
- Flat cable connection with cable piercing technique, variable flat cable guide
- Communication monitoring
- Inputs for 2-, 3-, and 4-wire sensors
- Power supply of outputs from the external auxiliary voltage
- Supply for inputs from AS-Interface
- Ground connection (FE) possible
- Function display for bus, ext. auxiliary voltage, inputs and outputs
- Detection of overload on sensor supply
- Detection of output overload

Release date: 2015-10-14 09:19 Date of issue: 2015-10-14 11:46:18_eng.xml

Technical data**General specifications**

Slave type	A/B slave
AS-Interface specification	V2.1
Required master specification	≥ V2.1
UL File Number	E223772

Indicators/operating means

LED FAULT	error display; LED red red: communication error or address is 0 red flashing: overload of sensor power supply or outputs
LED PWR	AS-Interface voltage; LED green
LED AUX	ext. auxiliary voltage U_{AUX} ; LED green
LED IN	switching state (input); 2 LED yellow
LED OUT	Switching state (output); 2 LED yellow

Electrical specifications

Auxiliary voltage (output)	U_{AUX}	20 ... 30 V DC PELV
Rated operating voltage	U_e	26.5 ... 31.6 V from AS-Interface
Rated operating current	I_e	≤ 40 mA (without sensors) / max. 140 mA
Protection class		III
Surge protection	U_{AUX}, U_{in} :	Over voltage category III, safe isolated power supplies (PELV)

Input

Number/Type	2 inputs for 2- or 3-wire sensors (PNP), DC option 1 input for 4-wire sensor (PNP), DC
Supply	from AS-Interface
Voltage	21 ... 31 V
Current loading capacity	≤ 100 mA ($T_B \leq 40 \text{ °C}$), ≤ 75 mA ($T_B \leq 60 \text{ °C}$), overload-proof and short-circuit protected
Input current	≤ 8 mA (limited internally)
Switching point	according to DIN EN 61131-2 (Type 2)
0 (unattenuated)	≤ 2 mA
1 (attenuated)	≥ 4 mA

Output

Number/Type	2 electronic outputs, PNP overload and short-circuit proof
Supply	from external auxiliary voltage U_{AUX}
Current	1 A per output
Voltage	≥ ($U_{AUX} - 0.5 \text{ V}$)

Programming instructions

Profile	S-B.A.2
IO code	B
ID code	A
ID1 code	7
ID2 code	2

Data bits (function via AS-Interface)	input	output
D0	-	OUT1
D1	-	OUT2
D2	IN3	-
D3	IN4	-

Parameter bits (programmable via AS-i)	function
P0	not used
P1	not used
P2	not used
P3	not used

Ambient conditions

Ambient temperature	-25 ... 60 °C (-13 ... 140 °F)
Storage temperature	-25 ... 85 °C (-13 ... 185 °F)
Relative humidity	85 % , noncondensing
Climatic conditions	For indoor use only
Altitude	≤ 2000 m above MSL
Pollution Degree	3

Mechanical specifications

Degree of protection	IP67
Connection	Cable piercing method flat cable yellow/flat cable black inputs/outputs: M12 round connector
Material	
Housing	PBT
Mass	100 g
Tightening torque, cable gland	0.4 Nm
Mounting	Mounting base

Compliance with standards and directives

Directive conformity	
EMC Directive 2004/108/EC	EN 61000-6-2:2001, EN 61000-6-4:2001, EN 50295:1999
Standard conformity	
Noise immunity	EN 61000-6-2:2001

Function

The VBA-2E2A-G2-ZA/EA2 is an AS-Interface interface module with 2 Inputs and 2 outputs. Mechanical contacts (e. g. push buttons) as well as 2-, 3- and 4-wire sensors can be connected to the inputs. The outputs are electronic outputs, which can be loaded to 24 V DC and 1 A per output.

The IP67 flat module is ideal for applications in the field. An addressing jack is integrated in the module.

Connection to the sensors/actuators is provided via M12 x 1 screw connections. An LED is provided for each channel, on the top of the module, to indicate the current switching status. Similarly, an LED is provided to monitor the AS-Interface communication and to indicate that the module has the address 0. LEDs are also provided to indicate the AS-Interface voltage and the external power supply.

The U-G3FF mounting base is normally used for the connection of the AS-Interface flat cable and the external 24 V DC power supply.

The specially designed base enables the user to connect flat cable from both sides.

The device is equipped with communication monitoring, which switches off power to the inputs if no communication has taken place for longer than 40 ms.

An overloading of the internal power supply or of the outputs is signalled to the AS-interface master via the "Peripheral fault" function. Communication via the AS-Interface remains intact.

Note:

The mounting base for the module is sold separately.

Accessories**VBP-HH1-V3.0-KIT**

AS-Interface Handheld with accessory

VBP-HH1-V3.0

AS-Interface Handheld

VAZ-PK-1,5M-V1-G

Adapter cable module/hand-held programming device

VAZ-FK-ED-G2

AS-Interface end seal for G2 modules

Matching system components**U-G3FF**

AS-Interface module mounting base for connection to flat cable (AS-Interface and external auxiliary power)

Emitted interference	EN 61000-6-4:2001
AS-Interface	EN 50295:1999
Input	EN 61131-2:2007
Degree of protection	EN 60529:2000

Notes

In the case of 4-wire sensors, you must use slot IN3 for the inputs (internally bridged).

Do not connect inputs and outputs, which are supplied via the module from AS-interface or via auxiliary power, with power supply and signal circuits with external potentials.