



**Model Number**

**UC3000+U9+E6+R2**

Single head system

**Features**

- **2 independent switch outputs**
- **Serial Interfaces**
- **Switch point setting via DIP-switches or RS 232 interface**
- **Synchronization options**
- **Temperature compensation**
- **Absolute polarity reversal protection**
- **Programmable with ULTRA 3000**

**Diagrams**

**Characteristic response curves**

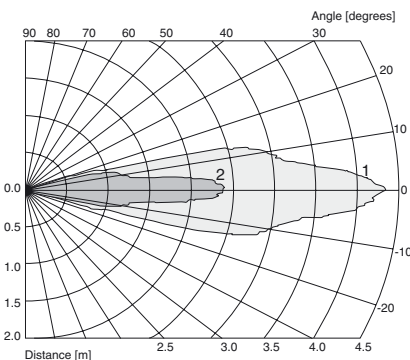

Curve 1: flat plate 100 mm x 100 mm  
Curve 2: round bar, Ø 25 mm

**Technical data**

**General specifications**

Sensing range	300 ... 3000 mm
Unusable area	0 ... 300 mm
Standard target plate	100 mm x 100 mm
Transducer frequency	approx. 130 kHz
Response delay	for factory setting minimum (EM; NONE): ≤80 ms (2 measuring cycles) default (EM, MXN, 5, 2): ≤160 ms (4 measuring cycles) dynamic (EM, DYN): ≤120 ms (3 measuring cycles)

**Indicators/operating means**

LED yellow	switching state switch output 1 switching state switch output 2
LED red/green	solid green : "Power on", flashes during standby operation red flashing : "Error", (e. g. background noise level too high)

**Electrical specifications**

Operating voltage $U_B$	20 ... 30 V DC , ripple 10 % <sub>SS</sub>
No-load supply current $I_0$	≤ 60 mA

**Interface**

Interface type	RS 232, 9600 bit/s, no parity, 8 data bits, 1 stop bit
----------------	--

**Input/Output**

Synchronization	1 synchronous connection, bidirectional 0-level: $-U_B \dots (-U_B + 1 V)$ , 1-level: $(-U_B + 5 V) \dots +U_B$
Pulse length	≥ 100 μs
Pause length	≥ 2 ms
Synchronization frequency	≤ 20 Hz , with external synchronisation

**Output**

Output type	2 switch outputs PNP, NO/NC
Rated operational current $I_e$	200 mA , short-circuit/overload protected
Voltage drop $U_d$	≤ 3 V DC
Resolution	< 1 mm
Repeat accuracy	≤ 0.1 % of full-scale value
Range hysteresis H	≤ 1 % of the set operating distance
Temperature influence	≤ 2 %

**Ambient conditions**

Ambient temperature	-25 ... 70 °C (-13 ... 158 °F)
Storage temperature	-40 ... 85 °C (-40 ... 185 °F)

**Mechanical specifications**

Protection degree	IP65
Connection	terminal compartment, ≤ 2.5 mm <sup>2</sup> conductor csa
Material	
Housing	PBT
Transducer	epoxy resin/hollow glass sphere mixture; polyurethane foam
Mass	180 g

**Compliance with standards and directives**

Standard conformity	
Standards	EN 60947-5-2:2007 IEC 60947-5-2:2007

**Approvals and certificates**

UL approval	cULus Listed, General Purpose
CSA approval	cCSAus Listed, General Purpose

Release date: 2012-01-25 13:54 Date of issue: 2012-01-25 036605\_eng.xml

**Dimensions**

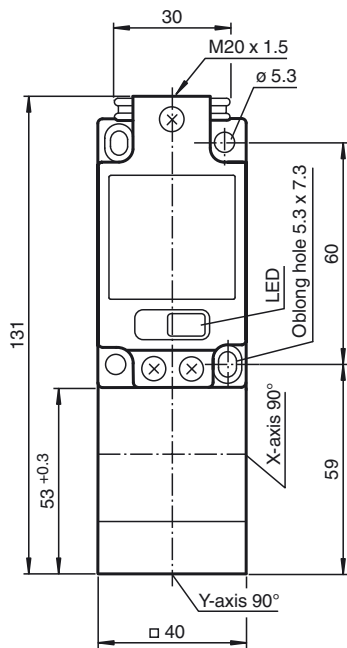

**Additional Information**

**LED-Window**

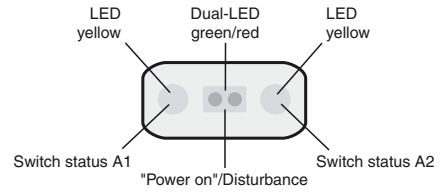

**Electrical Connection**

Standard symbol/Connection:  
(Version E6, pnp)

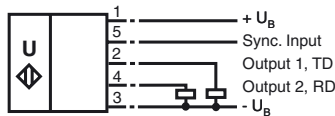

**Accessories**

**MH 04-2681F**

Mounting aid for VariKont, +U1+ and +U9\*

**ULTRA3000**

Software for ultrasonic sensors, comfort line

**UC-FP/U9-R2**

Interface cable

**Description of the sensor functions**

The outputs of the sensor can be used in two different operating modes: Switching mode with 2 adjustable switching points, or RS 232 mode (RS 232, 9600, n, 8, 1). Select the operating mode with DIP switch 10. The switching points are set with the DIP switches 1-4 and 5-8 (see table). Switch 9 is used to set the close or open function of the switch outputs.

For further information on the sensor's command set, please see the publication "Command Set for Ultrasonic Sensors with RS 232 Interface".

**Caution:** Ensure that DIP switch S10 is correctly set before connecting the RS 232 interface.

**Synchronisation**

The sensor features a synchronisation input for the suppression of mutual interference. If this input is not used, the sensor will operate using an internally generated clock rate. It can be synchronised by applying a square wave voltage. A falling edge leads to the transmission of a single ultrasonic pulse. A low level > 1 s or an open synchronisation input will result in the normal operation of the sensor. A high level > 1 s will result in the standby operation of the sensor (green LED).

Release date: 2012-01-25 13:54 Date of issue: 2012-01-25 036605\_eng.xml

Several functions are available:

- Two to five sensors can be synchronised by interconnecting their synchronisation inputs. In this case, the sensors alternately transmit ultrasonic pulses.
- Multiple sensors can be controlled by the same synchronisation signal. The sensors are synchronised.
- The synchronisation pulses are sent cyclically to individual sensors. The sensors operate in multiplex mode.

The response time increases when sensors are synchronised as the measuring cycle time is increased by the synchronisation.

**Adjustment of the evaluation window via coding switch in terminal compartment**

Switch 1 2 3 4	NDE [mm]	Switch 5 6 7 8	FDE [mm]
0 0 0 0	300	0 0 0 0	400
0 0 0 1	450	0 0 0 1	550
0 0 1 0	600	0 0 1 0	700
0 0 1 1	750	0 0 1 1	850
0 1 0 0	900	0 1 0 0	100
0 1 0 1	1050	0 1 0 1	1150
0 1 1 0	1200	0 1 1 0	1300
0 1 1 1	1350	0 1 1 1	1450
1 0 0 0	1500	1 0 0 0	1600
1 0 0 1	1700	1 0 0 1	1800
1 0 1 0	1900	1 0 1 0	2000
1 0 1 1	2100	1 0 1 1	2200
1 1 0 0	2300	1 1 0 0	2400
1 1 0 1	2500	1 1 0 1	2600
1 1 1 0	2700	1 1 1 0	2800
1 1 1 1	2900	1 1 1 1	3000

1  $\triangle$  ON, 0  $\triangle$  OFF

**DIP Switches in Terminal Compartment**

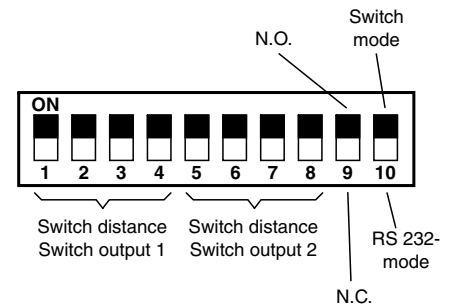

Thanks to its extensive command set, the sensor can be configured to suit the application via the RS 232 interface.

### RS 232 command set (overview)

Command	Meaning	Parameter	Access
VS0	Velocity of Sound at 0 °C	VS0 in [cm/s]	read and set
TO	Temperature Offset	TO in [0.1K]	read and set
TEM	TEMPerature	TEM in [0.1K]	read and adapt to TO
REF	REFerence measurement	REF distance in [mm]	adaptation of VS0
VS	Velocity of Sound	VS in [cm/s]	read
UDS	Use DIP Switches	UDS binary [0/1]	read and set
SD1[1]	Switching Distance 1 1	SD11 distance in [mm]	read and set
SD12	Switching Distance 1 2	SD12 distance in [mm]	read and set
SD2[1]	Switching Distance 2 1	SD21 distance in [mm]	read and set
SD22	Switching Distance 2 2	SD12 distance in [mm]	read and set
SH1	Switching Hysteresis 1	Hysteresis in [%]	read and set
SH2	Switching Hysteresis 2	Hysteresis in [%]	read and set
BR	Unusable area (Blind Range)	Unusable area to [mm]	read and set
RR	Range Reduction	Unusable area from [mm]	read and set
NEF	No Echo is Failure	1: "no echo" is failure; 0: "no echo" is not failure	read and set
FSF	Fail Safe Function	Shutdown function in event of failure	read and set
CBT	Constant Burst Time	Burst time in [µs]	read and set
CCT	Constant Cycle Time	Time in [ms]	read and set
SSY	Startup SYNchronised	SSY binary [0/1]	read and set
FTO	Filter TimeOut	Number of measurements without echo to be filtered	read and set
EM	Evaluation Method	Evaluation method { 0 = NONE; PT1[ <i>f,p,c</i> ]; MXN[ <i>m,n</i> ]; DYN[ <i>p</i> ] }	read and set
CON	CONservative filter	Counter threshold as number	read and set
OPM	Operation Method	Switch output operating mode { S,R,W,L,H } analogue output { S,L }	read and set
OM	Output Mode	OM coded [ close NO = 0, open NC = 1]	read and set
MD	Master Device	Function as master {0 = NONE},AD,RD,RT,SS,ATB,RDB,RTB }	read and set
DIP	DIP switch settings	DIP switch setting as hexadecimal string	read
AD	Absolute Distance	Distance in [mm]	read
RT	RunTime	Echo run time in machine cycles [1 machine cycle = 1.085µs]	read
SS1	Switching State 1	SS1 binary [0: inactive, 1 active] (independent of OM)	read
SS2	Switching State 2	SS2 binary [0: inactive, 1 active] (independent of OM)	read
ADB	Absolute Distance Binary	Distance in [mm], binary	read
RTB	RunTime Binary	Echo run time in machine cycles [1 machine cycle = 1.085µs], binary	read
ER	Echo Received	Echo detected: no, yes [0/1]	read
VER	VERsion	Version string: xxxx	read
ID	IDentification	ID string: P&F UC...-E6/E7-R2 Eprom: xxxx Version yyyy	read
DAT	DATe	Date string: e.g. Date: 06/11/96 Time: 16:14:26	read
ST	STatus	Status as hexadecimal string	read
RST	ReSeT	Performs a reset	Command
DEF	DEFault settings	Restores defaults	Command
SUC	Store User Configuration	Stores all settings	Command
RUC	Recall User Configuration	Restores stored settings	Command

### Programming instructions

**Caution:** When programming the sensor via the integrated RS 232 interface, ensure that DIP switch 10 is in the OFF (RS 232 mode) position before connecting the interface cable.

Electrical connection of interface cable UC-FP/U9-R2 (see accessories).

Interface cable Conductor colour	Sensor terminal compartment Terminal no.
brown (TD)	4 (RD)
black (RD)	2 (TD)
blue (GND)	3 (-U <sub>B</sub> )

**Structure of the filter functions**

