



Model Number

UC2000-F43-2KIR2-V17

Single head system

Features

- **Current output 4 mA ... 20 mA**
- **2 relay outputs**
- **Serial Interfaces**
- **Temperature compensation**
- **Reverse polarity protection**
- **Programmable with ULTRA 3000**

Diagrams

Characteristic response curve

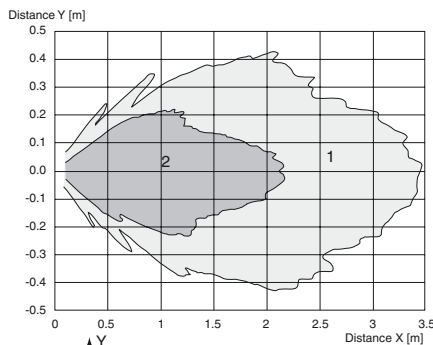

Curve 1: flat surface 100 mm x 100 mm
Curve 2: round bar, Ø 25 mm

Technical data

General specifications

Sensing range	100 ... 2000 mm
Unusable area	0 ... 100 mm
Standard target plate	100 mm x 100 mm
Transducer frequency	approx. 175 kHz
Response delay	minimum (EM; NONE): ≤50 ms (2 measuring cycles) factory setting (EM, MXN, 5, 2): ≤150 ms (6 measuring cycles) dynamic (EM, DYN): ≤75 ms (3 measuring cycles)

Indicators/operating means

LED green	continuous: object in the measuring window flashing: object outside the measuring window
LED red	error (e. g. interference level too high)

Electrical specifications

Operating voltage U_B	10 ... 30 V DC without current output function 15 ... 30 V DC with current output function ripple ± 10 % _{SS}
Power consumption P_0	≤ 2 W (all relays pulled-in, current output 20 mA) no-load power consumption ≤ 0.7 W

Interface

Interface type	RS 232, 9600 bit/s, no parity, 8 data bits, 1 stop bit
----------------	--

Output

Output type	2 relay outputs, 1 analog output 4 ... 20 mA
Resolution	0.5 mm
Deviation of the characteristic curve	< 0.2 % of full-scale value
Repeat accuracy	≤ 0.1 % of full-scale value
Range hysteresis H	0 ... 15 % programmable with ULTRA 2001
Load impedance	current output: ≤ 500 Ohm
Contact loading	60 V DC / 1 A (max. 24 V DC), ohmic
Life span	electrical: 3×10^5 switching cycles at resistive load (1 A / 24 V DC) mechanical: 10^7 switching cycles
Temperature influence	≤ 2 % , internal temperature compensation

Standard conformity

Standards	EN 60947-5-2
-----------	--------------

Ambient conditions

Ambient temperature	-25 ... 70 °C (-13 ... 158 °F)
Storage temperature	-40 ... 85 °C (-40 ... 185 °F)

Mechanical specifications

Connection type	Device connector M12 x 1 , 8-pin screen connected to pin 8
Protection degree	IP65
Material	PBT
Housing	PBT
Transducer	epoxy resin/hollow glass sphere mixture; polyurethane foam
Mass	290 g

Dimensions

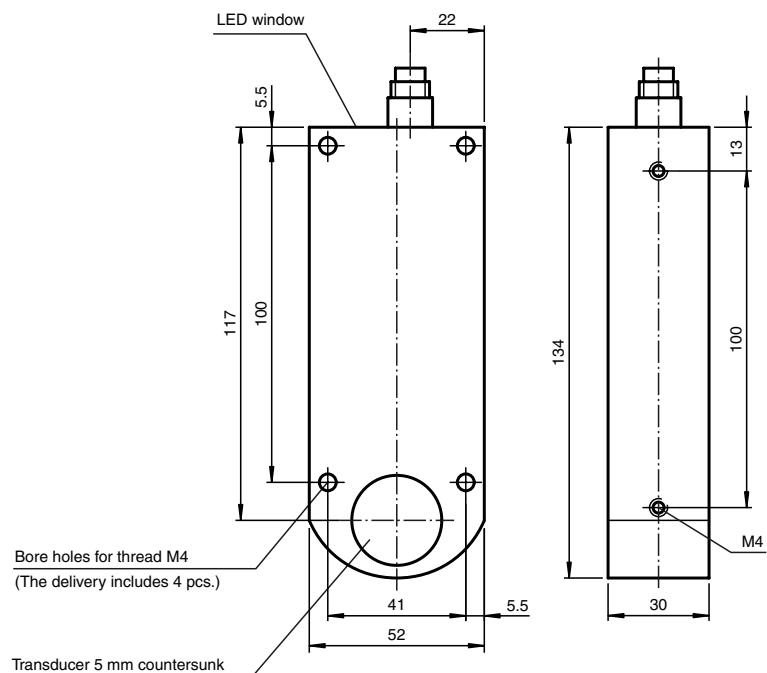

Release date: 2013-02-25 13:49 Date of issue: 2013-02-25 095111_eng.xml

Electrical Connection

Standard symbol/Connection:

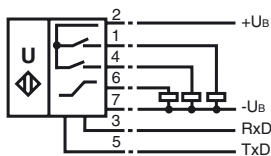

Pinout

Connector V17



Accessories

UC-F43-R2

ULTRA3000

Software for ultrasonic sensors, comfort line

V17-G-2M-PUR

Cable socket, M12, 8-pin, shielded, PUR cable

V17-G-5M-PUR

Cable socket, M12, 8-pin, shielded, PUR cable

Thanks to its extensive command set, the sensor can be configured to suit the ap-

Additional Information

Basic setting

OM:

Relay 1: NO

Relay 2: NO

SD1/SD2:

Switch point relay 1 = 100 mm

Switch point relay 2 = 2000 mm

NDE/FDE:

Analogue output: 4 mA ⇒ 100 mm

20 mA ⇒ 2000 mm

FSF:

Error ⇒ Relay 1 and 2: latest state

⇒ Analogue output: I_{out} = 3,9 mA

NEF:

No echo ⇒ error message

MA,S:

Switching mode

plication via the RS 232 interface.

RS 232 command set (overview)			
Command	Meaning	Parameter	Access
VS0	Velocity of Sound at 0 °C	Velocity of sound at 0 °centigrade VS0 in [cm/s] {12000 ... 60000}	read and set
VS	Velocity of Sound	Velocity of sound VS in [cm/s]	read
TO	Temperature Offset	TO in [0.1K]	read and set
TEM	TEMPerature	TEM in [0.1K]	read and adapt to TO
REF	REFerence measurement	REF distance in [mm] {100 ... 4000}	adaptation of VS0
SD1	Switching Distance 1	Switching point, relay 1 SD1 in [mm] {100 ... 4000}	read and set
SD2	Switching Distance 2	Switching point, relay 2 SD1 in [mm] {100 ... 4000}	read and set
SH1	Switching Hysteresis 1	Hysteresis, relay 1 in [%] {0 ... 15}	read and set
SH2	Switching Hysteresis 2	Hysteresis, relay 2 in [%] {0 ... 15}	read and set
NDE	Near Distance of Evaluation	Near measuring window limit in [mm] {100 ... 4000}	read and set
FDE	Far Distance of Evaluation	Far measuring window limit in [mm] {100 ... 4000}	read and set
BR	Unusable area (Blind Range)	Unusable area in [mm] {100 ... 4000}	read and set
CBT	Constant Burst Time	Burst length in [µs] {0, 1, 2, 3}	read and set
CCT	Constant Cycle Time	Time in [ms] {0 ... 1000}	read and set
FTO	Filter TimeOut	Number of measurements without echo to be filtered {0 ... 255}	read and set
EM	Evaluation Method	Evaluation method { 0 = NONE; PT1[,f,p,c]; MXN[,m,n]; DYN[,p] }	read and set
CON	CONservative filter	Counter threshold as number {0 ... 255}	read and set
OM	Output Mode	OM coded [normally-open NO = 0, normally-closed NC = 1]	read and set
FSF	Fail Safe Function	Failure function type e.g. FSF,11,35 {0,1,2}, [fault current in 0.1 mA]	read and set
MD	Master Device	Function as master {0 = NONE},AD,RD,RT,SS,ADB,RDB,RTB }	read and set
MA	Main Application	Determines whether the green LED orients itself according to NDE, FDE or SD1 and SD2	read and set
NEF	No Echo Failure	Sensor behaviour when no echo is present {0,1}	read and set
AD	Absolute Distance	Distance in [mm]	read
RD	Relative Distance	Relative distance as number {0 ... 4095}	read
RT	RunTime	Echo run time in machine cycles [1 machine cycle = 1.085µs]	read
SS1	Switching State 1	SS1 binary [0: inactive, 1 active] (independent of OM)	read
SS2	Switching State 2	SS2 binary [0: inactive, 1 active] (independent of OM)	read
ADB	Absolute Distance Binary	Distance in [mm] not as ASCII	read
RDB	Relative Distance Binary	Relative distance as number {0 ... 4095} not as ASCII	read
RTB	RunTime Binary	Echo run time in machine cycles [1 machine cycle = 1.085µs] not as ASCII	read
ER	Echo Received	Echo detected: no, yes [0/1]	read
VER	VERsion	Version string: xxxx	read
ID	IDentification	ID string: P&F UC2000-F43-2KIR2-V17...	read
DAT	DATE	Date string: e.g. Date: e.g. 04/12/99 Time: 11:14:35	read
ST	STatus	Status as hexadecimal string	read
RST	ReSeT	Performs a reset	Command
DEF	DEFault settings	Restores defaults	Command
SUC	Store User Configuration	Stores all settings	Command
RUC	Recall User Configuration	Restores stored settings	Command

Release date: 2013-02-25 13:49 Date of issue: 2013-02-25 095111_eng.xml