

Through-beam ultrasonic barrier UBE1500-F64-SE0



Features

- Reliable detection of transparent materials
- High switching frequency
- Small angle of divergence
- Small, compact design
- Plastic housing
- Emitter and receiver included in the delivery package

Electrical connection

Standard symbol/Connection:

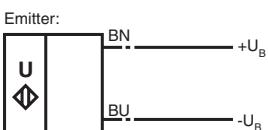
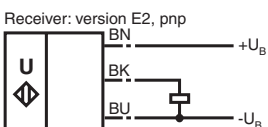
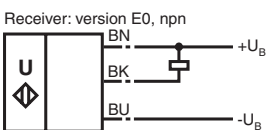

Dimensions

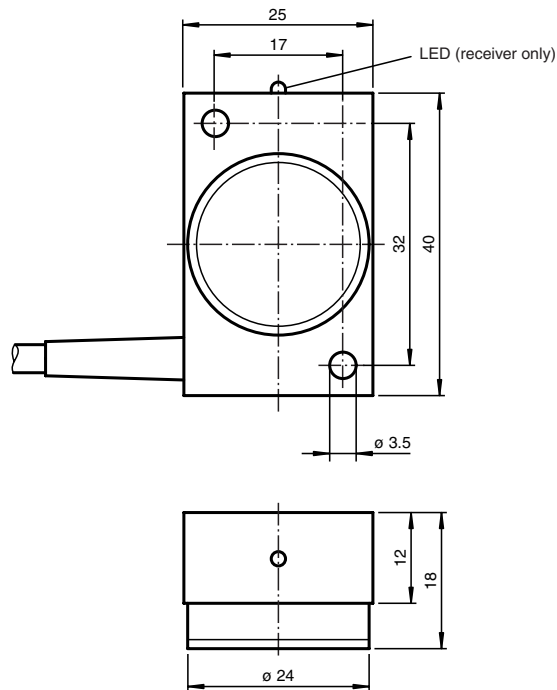

Technical data

General specifications

Sensing range	0 ... 1500 mm , distance emitter-receiver 20 mm ... 1500 mm
Transducer frequency	200 kHz
Reference target	receiver

Indicators/operating means

LED yellow	indication of the switching state (receiver)
------------	--

Electrical specifications

Operating voltage	18 ... 30 V DC , ripple 10 % _{SS}
No-load supply current I ₀	20 mA receiver 12 mA emitter

Output

Output type	1 switch output E0, npn NO
Rated operational current I _e	50 mA
Voltage drop U _d	≤ 0,5 V
Switching frequency f	120 Hz
Switch-on delay t _{on}	< 5 ms

Standard conformity

Standards	EN 60947-5-2
-----------	--------------

Ambient conditions

Ambient temperature	0 ... 60 °C (273 ... 333 K)
Storage temperature	-40 ... 85 °C (233 ... 358 K)

Mechanical specifications

Protection degree	IP54
Connection	2 m, PVC cable emitter: 2 x 0.34 mm ² receiver: 3 x 0.34 mm ²

Material

Housing	PA 6.6
Mass	80 g per device

Function

A through-beam ultrasonic barrier always consists of a single emitter and a single receiver. The function of a through-beam ultrasonic barrier is based in the interruption of the sound transmission to the receiver by the object to be detected. The emitter sends an ultrasonic signal that is evaluated by the receiver. If the signal is interrupted or muted by the object to be detected, the receiver switches. No electrical connections are required between the emitter and receiver. The function of through-beam ultrasonic barriers is not dependent on the position of their installation. We recommend, however, to install the emitter below in the case of vertical installations to prevent the accumulation of dust particles.

Installation tolerances

The installation tolerances of the central axes of the emitter and receiver may not exceed the values specified in the illustration.

Detection of thin foils

For the detection of thin foils (< 0.1 mm), install the through-beam ultrasonic barrier at an angle of $\geq 10^\circ$ from perpendicular to the foil.

Caution

Mount or replace emitter and receiver only in pairs. Both devices are optimally matched to each other by the manufacturer.

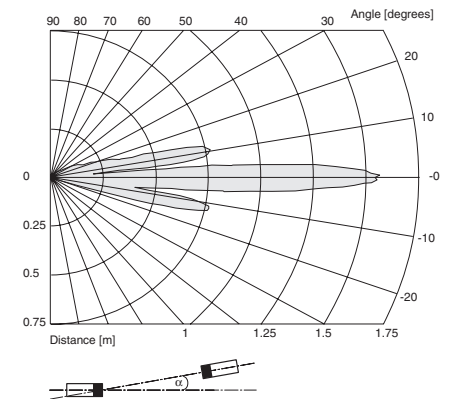
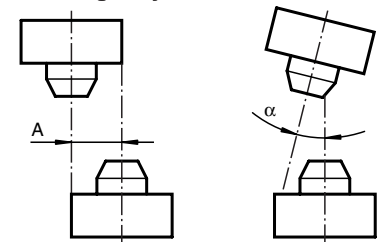
UBE1500-F64-SE0**Characteristic curves/additional information****Characteristic response curves****Mounting/Adjustment**

Parallel displacement $A \leq 8 \text{ mm}$ Angle displacement $\alpha \leq 5^\circ$

Thin foil detection