



Model Number

UB3000+U9+H3

Single head system

Features

- Separate evaluation
- With temperature sensor
- Direct detection mode

Diagrams

Characteristic response curves

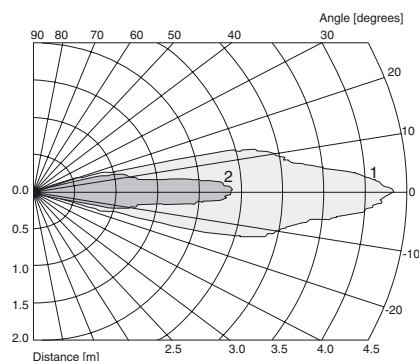

Curve 1: flat plate 100 mm x 100 mm
Curve 2: round bar, Ø 25 mm

Technical data

General specifications

Sensing range	300 ... 3000 mm
Unusable area	0 ... 300 mm ¹⁾
Standard target plate	100 mm x 100 mm
Transducer frequency	approx. 130 kHz

Electrical specifications

Operating voltage U_B	20 ... 30 V DC, ripple 10 % _{SS}
No-load supply current I_0	≤ 30 mA

Input

Input type	1 pulse input for transmitter pulse, activation through open collector npn < 1 V: emitter active, > 4 V: emitter inactive
Pulse length	20 ... 500 μs (typ. 300 μs) ²⁾
Pause length	≥ 50 x pulse length

Output

Output type	1 pulse output for temperature 1-level: > 4 V (100 μA), 0-level: < 0.5 V (100 μA) 1 pulse output for echo propagation time 1-level: ≥ $U_B - 3 V$ (< 10 mA), 0-level: ≤ 1 V (100 μA)
Pulse length	10 μs/K + timer pulse, synchronisation with the timer pulse
Temperature influence	the echo propagation time: ≤ 0.17 % / K

Ambient conditions

Ambient temperature	-25 ... 70 °C (-13 ... 158 °F)
Storage temperature	-40 ... 85 °C (-40 ... 185 °F)

Mechanical specifications

Protection degree	IP65
Connection	terminal compartment, ≤ 2.5 mm ² conductor csa
Material	
Housing	PBT
Transducer	epoxy resin/hollow glass sphere mixture; polyurethane foam
Mass	180 g

Compliance with standards and directives

Standard conformity	
Standards	EN 60947-5-2:2007 IEC 60947-5-2:2007

Approvals and certificates

UL approval	cULus Listed, General Purpose
CSA approval	cCSAus Listed, General Purpose

Dimensions

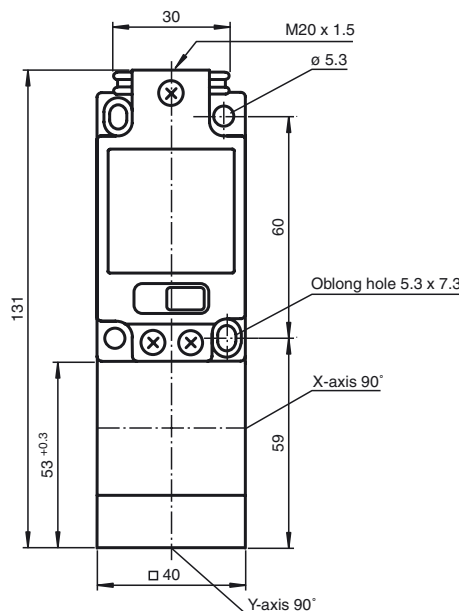

Release date: 2013-02-04 09:43 Date of issue: 2013-02-04 036878_eng.xml

Electrical Connection

Standard symbol/Connection:

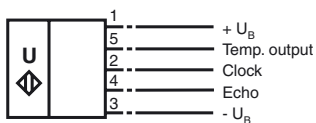

Additional Information

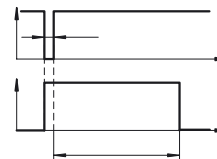

Accessories

MH 04-2681F

Mounting aid for VariKont, +U1+ and +U9*

UH3-KHD2-4E5

UH3-KHD2-4I

UH3-T1-KT

Description of the sensor functions

The sensing range is determined in the downstream evaluation electronics (e. g. the units UH3-KHD2-4E5, or UH3-KHD2-4I).

The sensing range is determined on the basis of the echo time of a transmitted pulse in pulse-echo mode.

Temperature compensation

A temperature pulse is available at the temperature output for external temperature compensation. It is synchronous to the externally applied clock pulse and has the length T_{Temp}, calculated as follows:

$$T_{Temp}[\mu s] = T_{Takt}[\mu s] + T[K] \times 10\mu s/K$$

Put into the formula the temperature in Kelvin and the clock time in the unit μs .

- 1) The unusable area (blind range) BR depends on the pulse duration. The unusable area reaches a minimum with the shortest pulse duration.
- 2) The sensors detection range depends on the pulse duration. With pulse duration < typical pulse duration, the sensors detection range may be reduced.