

Model Number

UB1000+FP2+E6

Features

- Through-beam and direct detection modes
- 2 independent switch outputs
- 4 operating modes can be set

Curves

Characteristic response curves

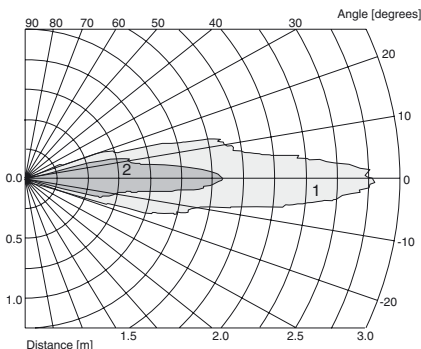

Curve 1: flat surface 100 mm x 100 mm
Curve 2: round bar, Ø 25 mm

Technical data

General specifications

Sensing range	200 ... 1000 mm
Unusable area	0 ... 200 mm
Standard target plate	100 mm x 100 mm
Transducer frequency	approx. 175 kHz
Response delay	≤ 100 ms

Indicators/operating means

LED green	Power on
LED yellow	switch output 1
	switch output 2
LED red	fault (due to external noise or incorrect adjustment)
DIP-switch	S9= ON/NO
	S9= OFF / NC
	S10= ON/Window operation (barrier mode)
	S10= OF/independent switch points

Electrical specifications

Operating voltage U_B	20 ... 30 V DC , ripple 10 % _{SS}
No-load supply current I_0	≤ 90 mA

Output

Output type	2 switch outputs PNP, NO/NC
Rated operational current I_e	200 mA , short-circuit/overload protected
Voltage drop U_d	≤ 3 V DC
Repeat accuracy	≤ 1 %
Switching frequency f	≤ 5 Hz
Range hysteresis H	≤ 5 % of the set operating distance
Temperature influence	≤ 0.17 % / K

Ambient conditions

Ambient temperature	-10 ... 50 °C (14 ... 122 °F)
Storage temperature	-40 ... 85 °C (-40 ... 185 °F)

Mechanical specifications

Protection degree	IP65
Connection	terminal compartment, ≤ 2.5 mm ² conductor csa
Material	
Housing	PBT
Transducer	epoxy resin/hollow glass sphere mixture; polyurethane foam
Mass	338 g

Compliance with standards and directives

Standard conformity	
Standards	EN 60947-5-2:2007 IEC 60947-5-2:2007

Approvals and certificates

UL approval	cULus Listed, General Purpose
CSA approval	cCSAus Listed, General Purpose

Release date: 2010-11-19 14:25 Date of issue: 2010-11-19 032522_ENG.xml

Dimensions

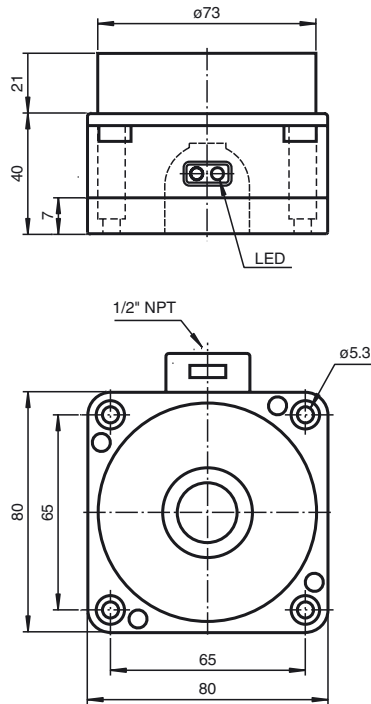

Electrical Connection

Standard symbol/Connection:

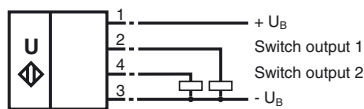

Description of the sensor functions

The sensor is suitable for direct-detection mode as well as beam-interruption mode. The functions of the outputs can be set with switches S9 and S10 in accordance with the following table.

Switch	Switching range
S1	200 ... 300 mm
S2	300 ... 400 mm
S3	400 ... 500 mm
S4	500 ... 600 mm
S5	600 ... 700 mm
S6	700 ... 800 mm
S7	800 ... 900 mm
S8	900 ... 1000 mm

A continuous switching range must be selected. When operating with independent switching points, A1 switches the upper limit and A2 the lower limit of the switching range.

Barrier mode

In barrier mode, primarily the range up to objects used as reflector will be evaluated (e. g. machine part). Objects entering the range between the sensor and reflector are detected. This includes objects of a strongly sound-absorbent nature and objects positioned at an angle to the sensor's active axis. In this case, no echo reaches the receiver. If the sound is reflected by an object, the reflection will have a different echo time from the regular reflector echo. The sensor detects the object on the basis of the shorter echo time or lack of an echo while in barrier mode.

DIP Switches in Terminal Compartment

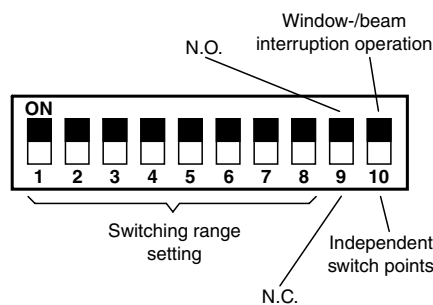

Additional Information

Output functions

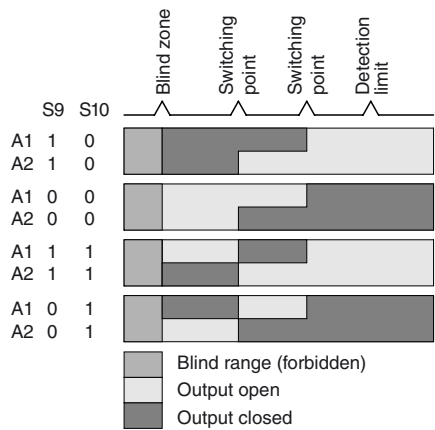

LED-Window

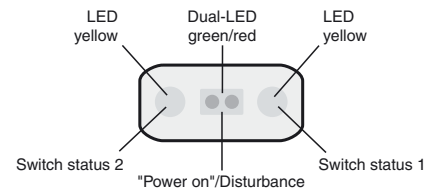

Accessories

MH 04-3505
Mounting aid for FP sensors

MHW 11
Mounting brackets for sensors

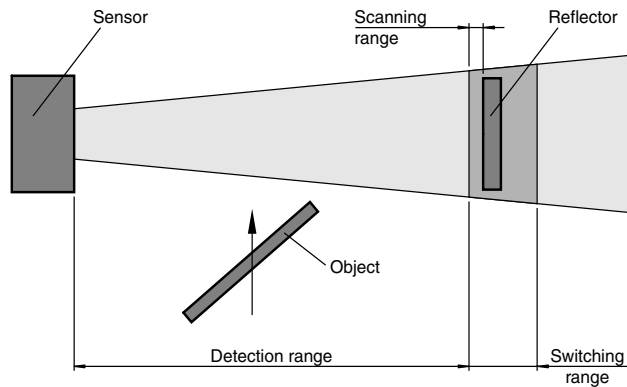

For use as a barrier, set the close function ($S9 = 1$) and window mode (barrier mode) ($S10 = 1$). The distance between the sensor and the reflector determines the switching range which must be set using a switch between S1 and S8. Only one switch may be set to "ON", resulting in a switching range of 100 mm.

The sensor and/or reflector should be adjusted in such a manner that output A1 is closed. The reflector should be positioned as closely as possible to the sensor's near switching range limit. The sensor works in direct-detection mode in the area between the reflector and the sensor's near limit. A reliable evaluation is therefore not possible.

If an interruption of the barrier by an object is determined during operation, switch output A1 is opened. Output A2 is not taken into consideration as a rule, as it also works in direct-detection mode rather than beam-interruption mode.