

TS-PT100 CONTACT SENSOR

Temperature sensors

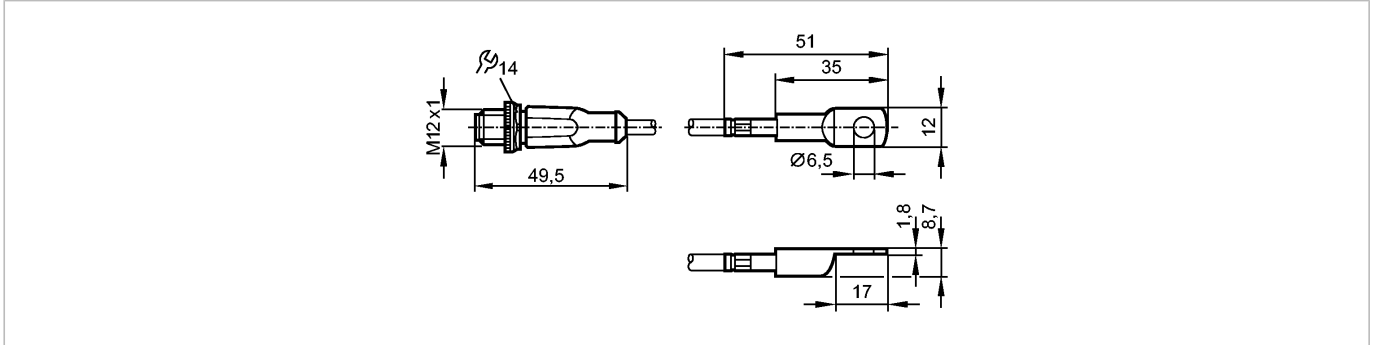

Product characteristics

Temperature sensor for connection to evaluation units

Bolt-on sensor 12 x 8.7 x 51 mm

Cable with connector

gold-plated contacts

Connection to control monitor TP / TR

Measuring range: -40...90 °C / -40...194 °F

Measuring element: 1 x Pt 100, to DIN EN 60751, class A

Application

Application Contact sensor for solid bodies

Electrical data

Connection to control monitor TP / TR

Protection class III

Inputs

Insulation rating 2500 V **)

Measuring / setting range

Measuring range -40...90 °C | -40...194 °F

Accuracy / deviations

Accuracy ± (0.15 K + 0.002 x |t|)

Reaction times

Dynamic response T05 / T09 [s] 9 / 15 *)

Environment

Protection IP 67

Tests / approvals

MTTF [Years] 22831

Mechanical data

Housing materials stainless steel 305/1.4303; copper nickel-plated

Weight [kg] 0.087

Electrical connection

Connection PUR cable / 2 m;
4 x 0.34 mm² (42 x Ø 0.1 mm); Ø 4.9 mm; halogen-free, with M12 connector

Wiring

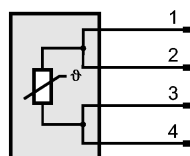

Remarks

Remarks

*) Values for a flat aluminium surface (anodised) using a conductive heat paste.

Reference values for moving water (< 0.1 m/s): 10 (T05) / 24 (T09)

TS2229 - Temperature sensor for connection to evaluation units - eclass: 27200214 / 27-20-02-14

Pack quantity	[piece]	**) Insulation between sensor housing and internal	1
---------------	---------	--	---