

replaced by: SI5010

efector300
SI1000



SID10ADBFPKG/US-100-IPF

Flow sensors

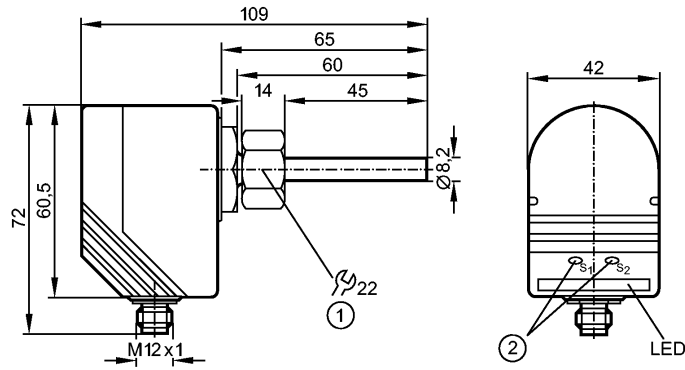

- 1: internal thread M18 x 1.5
2: setting pushbuttons



Product characteristics

Flow monitor

Compact type for adapter

Process connection: internal thread M18 x 1.5 for adapter

Setting range: 3...300 cm/s (liquids)

Application

Application

liquids and gases

Pressure rating [bar]

300

Medium temperature [°C]

-25...80

Electrical data

Electrical design

DC PNP

Operating voltage [V]

20...36 DC ¹⁾

Current consumption [mA]

< 80

Reverse polarity protection

yes

Outputs

Output function

normally open / closed programmable

Current rating [mA]

400

Voltage drop [V]

< 2.5

Short-circuit protection

yes (non-latching)

Overload protection

yes

Measuring / setting range

Liquids

Setting range [cm/s]

3...300

Greatest sensitivity [cm/s]

3...60

Gases

Setting range [cm/s]

200...3000

Greatest sensitivity [cm/s]

200...800

Accuracy / deviations

Max. temperature gradient of medium [K/min]

300

Reaction times

Power-on delay time [s]

15 *)

Response time [s]

1...10

Software / programming

Adjustment of the switch point

pushbuttons

Environment

SI1000 - Flow monitor - eclass: 27273101 / 27-27-31-01

Ambient temperature	[°C]	-25...80
Protection		IP 67
Tests / approvals		
Shock resistance		DIN IEC 68-2-27: 50 g (11 ms)
Vibration resistance		DIN EN 60068-2-6 20 g (55...2000 Hz)
MTTF	[Years]	258
Mechanical data		
Process connection		internal thread M18 x 1.5 for adapter
Materials (wetted parts)		stainless steel 316L / 1.4404; O-ring: FKM 8 x 1.5 gr 80° Shore A
Housing materials		PBT-GF 20
Weight	[kg]	0.255
Displays / operating elements		
Function display	LED	10 LEDs, three-colour
Electrical connection		
Connection		M12 connector

Wiring

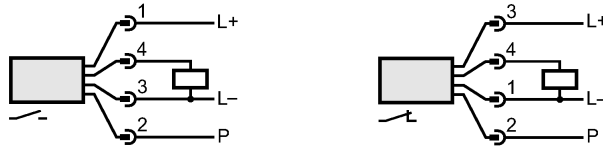

P = programming wire (for remote adjustment)

Remarks	
Remarks	1) to EN50178, SELV, PELV *) optically indicated
Pack quantity	[piece] 1