



Model Number

RC10-14-N3

Features

- 10 mm inside diameter
- Bistable
- Direction detection

Technical Data

General specifications

Switching function	Normally closed (NC)
Output type	NAMUR, bistable
Installation	
Inside diameter	10 mm
Measuring cylinder	
Diameter	2.5 mm
Length	3 mm
Measuring cone	
Material	9S20K

Nominal ratings

Nominal voltage	U_o	8.2 V (R_i approx. 1 k Ω)
Hysteresis	H	typ. 1 %
Reverse polarity protection		reverse polarity protected
Current consumption		
Traverse B		3 mA
Traverse A		1 mA
Time delay before availability	t_v	≤ 5 ms

Functional safety related parameters

MTTF _d	2144 a
Mission Time (T_M)	20 a
Diagnostic Coverage (DC)	0 %

Ambient conditions

Ambient temperature	-20 ... 100 °C (-4 ... 212 °F)
---------------------	--------------------------------

Mechanical specifications

Connection type	cable PVC , 2 m
Core cross-section	0.14 mm ²
Housing material	PBT
Degree of protection	IP67
Cable	
Bending radius	> 10 x cable diameter

General information

Use in the hazardous area	see instruction manuals
Category	2G

Compliance with standards and directives

Standard conformity	
NAMUR	EN 60947-5-6:2000 IEC 60947-5-6:1999
Standards	EN 60947-5-2:2007 IEC 60947-5-2:2007

Approvals and certificates

FM approval	
Control drawing	116-0165F
UL approval	cULus Listed, General Purpose
CSA approval	cCSAus Listed, General Purpose

Dimensions

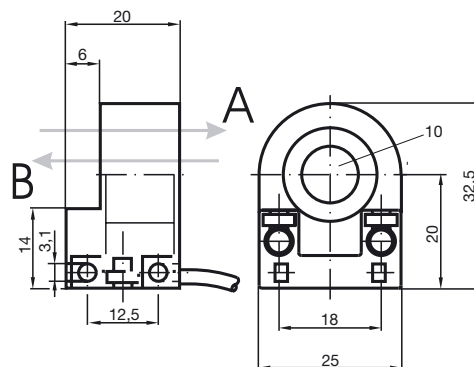

Electrical Connection



Release date: 2016-11-07 09:53 Date of issue: 2016-11-07 051666_eng.xml

Equipment protection level Gb

Instruction

Device category 2G

EC-Type Examination Certificate

CE marking

ATEX marking

Standards

Appropriate type

Effective internal inductivity C_i Effective internal inductance L_i

General

Maximum permissible ambient temperature T_{amb}

Installation, commissioning

Maintenance

Manual electrical apparatus for hazardous areas

for use in hazardous areas with gas, vapour and mist

PTB 99 ATEX 2128 X

CE 0102

II 2G Ex ia IIC T6...T1 Gb

EN 60079-0:2012, EN 60079-11:2012

Ignition protection "Intrinsic safety"

Use is restricted to the following stated conditions

RC10-...-N3...

 ≤ 90 nF ; a cable length of 10 m is considered. ≤ 120 μ H ; a cable length of 10 m is considered.

The apparatus has to be operated according to the appropriate data in the data sheet and in this instruction manual. The EU-type examination certificate has to be observed. The special conditions must be adhered to!

The temperature ranges, according to temperature class, are given in the EC-Type Examination Certificate.

Laws and/or regulations and standards governing the use or intended usage goal must be observed. The intrinsic safety is only assured in connection with an appropriate related apparatus and according to the proof of intrinsic safety. Install the device in such a way that the resin surface is not exposed to mechanical hazards.

No changes can be made to apparatus, which are operated in hazardous areas. Repairs to these apparatus are not possible.