

New generation available: PN2099

**efectorsoo**

PN2009



PN-1-1BRBR14-MFRKG/US/ IV

Pressure sensors

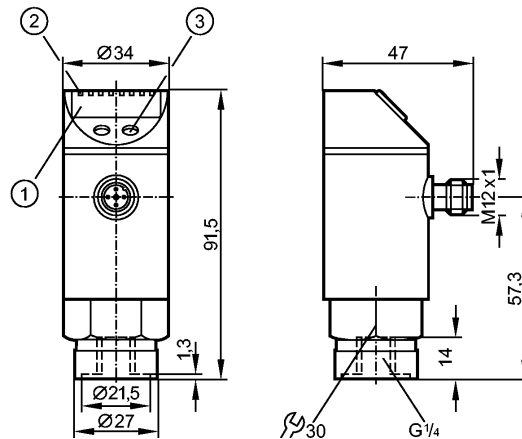

- 1: 4-digit alphanumeric display
- 2: LEDs (display unit / switching status)
- 3: Programming button



Product characteristics

Combined pressure sensor

Quick disconnect

Zero and span adjustable

Function programmable

Process connection: G 1/4 I

2 outputs

OUT1 = switching output

OUT2 = switching output or analog output

4-digit alphanumeric display

Measuring range: -1000...1000 mbar / -14.5...14.5 psi

Application

Application

Type of pressure: relative pressure  
Liquids and gases

Pressure rating

20000 mbar

290 psi

Bursting pressure min.

50000 mbar

725 psi

Medium temperature [°C]

-25...80

Electrical data

Electrical design

DC PNP/NPN

Operating voltage [V]

18...32 DC 1)

Current consumption [mA]

< 35

Insulation resistance [MΩ]

> 100 (500 V DC)

Protection class

III

Reverse polarity protection

yes

Outputs

Output

2 outputs

OUT1 = switching output

OUT2 = switching output or analog output

Output function

2 x normally open / closed programmable or 1 x normally open / closed programmable  
+ 1 x analog (4...20 mA / 0...10 V; programmable 1:4)

Current rating [mA]

2 x 250

Voltage drop [V]

< 2

Short-circuit protection

yes (non-latching)

Overload protection

yes

**PN2009 - Combined pressure sensor - eclass: 27201302 / 27-20-13-02**

Switching frequency [Hz]	≤ 500	
Analog output	4...20 mA / 0...10 V	
Max. load [Ω]	4...20 mA: max. (U <sub>b</sub> - 10 V) x 50 / 0...10 V: min. 2000	
Measuring / setting range		
Display unit	mbar, kPa, psi, inH <sub>2</sub> O, inHg	
Measuring range	-1000...1000 mbar	-14.5...14.5 psi
Setting range		
Set point, SP	-988...1000 mbar	-14.3...14.5 psi
Reset point, rP	-996...992 mbar	-14.4...14.4 psi
Analog start point, ASP	-996...500 mbar	-14.4...7.3 psi
Analog end point, AEP	-500...1000 mbar	-7.2...14.5 psi
in steps of	4 mbar	0.1 psi
Factory setting	SP1 = -500 mbar; rP1 = -540 mbar SP2 = 500 mbar; rP2 = 460 mbar ASP = -996 mbar; AEP = 1000 mbar	
Accuracy / deviations		
Accuracy / deviations (in % of the span) Turn down 1:1		
Switch point accuracy	< ± 0.4	
Characteristics deviation *)	< ± 0.25 (BFSL) / < ± 0.5 (LS)	
Hysteresis	< ± 0.1	
Repeatability **)	< ± 0.1	
Long-term stability ***)	< ± 0.1	
Temperature coefficients (TEMPCO) in the temperature range -25...80° C (in % of the span per 10 K)		
Greatest TEMPCO of the zero point	< ± 0.2	
Greatest TEMPCO of the span	< ± 0.2	
Reaction times		
Power-on delay time [s]	0.3	
Min. response time switching output [ms]	1.5	
Damping for the switching output (dAP) [s]	0; 0.01...4.00	
Damping for the analog output (dAA) [s]	0; 0.01...4.00	
Response time analog output [ms]	3	
Integrated watchdog	yes	
Software / programming		
Programming options	hysteresis / window function; N.O. / N.C; output polarity; current / voltage outputs; damping; calibration of displayed values; display can be rotated / deactivated; display unit	
Interfaces		
IO-Link Device		
Transfer type	COM2 (38.4 kBaud)	
IO-Link revision	1.0	
IO-Link Device ID	64 d / 00 00 40 h	
Profiles	no profile	
SIO mode	yes	
Required master port class	A	
Process data analogue	1	
Process data binary	2	
Min. process cycle time [ms]	2.3	
Environment		
Ambient temperature [°C]	-25...80	
Storage temperature [°C]	-40...100	
Protection	IP 65	
Tests / approvals		
EMC	EN 61000-4-2 ESD:	4 kV CD / 8 kV AD
	EN 61000-4-3 HF radiated:	10 V/m

**PN2009 - Combined pressure sensor - eclass: 27201302 / 27-20-13-02**

	EN 61000-4-4 Burst:	2 kV
	EN 61000-4-5 Surge:	0.5/1 kV
	EN 61000-4-6 HF conducted:	10 V
Shock resistance	DIN IEC 68-2-27:	50 g (11 ms)
Vibration resistance	DIN IEC 68-2-6:	20 g (10...2000 Hz)
MTTF [Years]		131
Mechanical data		
Process connection		G ¼ I
Materials (wetted parts)		stainless steel (303S22); ceramics; FPM (Viton)
Housing materials		stainless steel (304S15); stainless steel 316L / 1.4404; PC (Makrolon); PBT (Pocan); PEI; FPM (Viton); PTFE
Switching cycles min.		100 million
Weight [kg]		0.263
Displays / operating elements		
Display	Display unit	5 x LED green
	Switching status	2 x LED yellow
	Function display	4-digit alphanumeric display
	Measured values	4-digit alphanumeric display
Electrical connection		
Connection		M12 connector; gold-plated contacts
<b>Wiring</b>		
Programming of the output function (OUT1 / OUT2): Hno = hysteresis / normally open Hnc = hysteresis / normally closed Fno = window function / normally open Fnc = window function / normally closed Complementary outputs: output 1: = Hno, output 2: = Hnc (with the same SP / rP)		
Programming of the analog output (OUT2): I = current output (4...20 mA) U = voltage output (0...10 V)		
Remarks		1) to EN50178, SELV, PELV *) BFSL = Best Fit Straight Line / LS = Limit Value Setting **) with temperature fluctuations < 10 K ***) in % of the span per year
Pack quantity [piece]		1