

no longer available - archive entry replaced by: TW7001 + E35065

efector600

OW5005



OWL-3506-BPKG

Temperature sensors

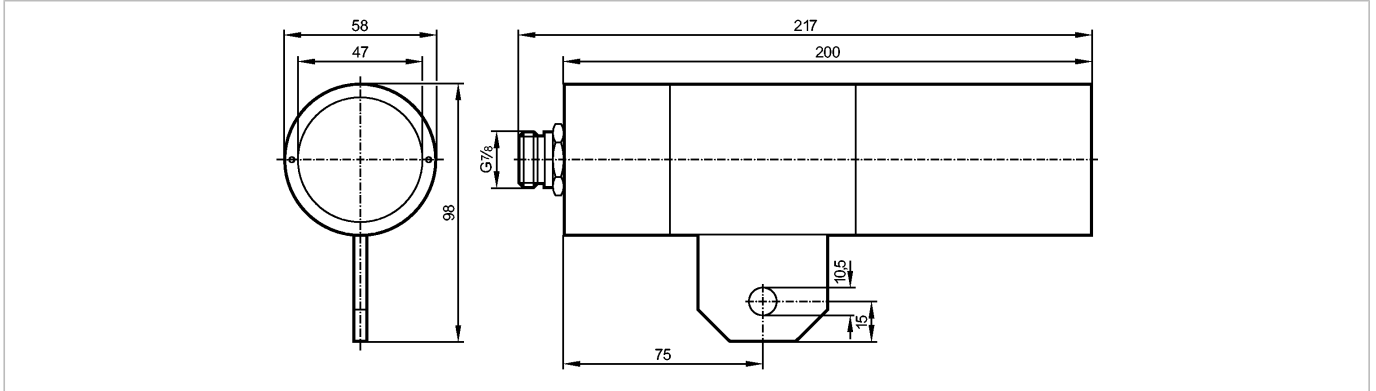

Product characteristics

Infrared heat sensor

Metal housing

Quick disconnect

Switching temperature 350 °C

Angle of aperture 0.6°

Electrical data

Electrical design

DC PNP

Operating voltage [V]

10...55 DC

Current consumption [mA]

< 20

Protection class

II

Reverse polarity protection

yes

Outputs

Output function

normally open

Voltage drop [V]

< 2.5

Current rating [mA]

400

Short-circuit protection

yes (non-latching)

Overload protection

yes

Switching frequency [Hz]

1000

Monitoring range

Hysteresis [%]

1...15

Environment

Ambient temperature [°C]

-20...60

Protection

IP 65

Tests / approvals

EMC

EN 60947-5-2

EN 55011:

class B

Mechanical data

Housing materials

brass white bronze coated

Lens material

glass

Weight [kg]

1.417

Displays / operating elements

Output status indication LED

yellow

Electrical connection

Connection

7/8" connector

Wiring

OW5005 - Infrared heat sensor - eclass: 27371245 / 27-37-12-45

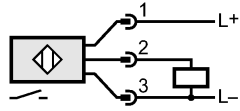
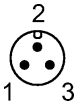

Remarks

Pack quantity [piece] 1

ifm efector, inc. • 1100 Atwater Drive • Malvern • PA 19355 — We reserve the right to make technical alterations without prior notice. — US — OW5005 — 06.03.2003
no longer available - archive entryreplaced by: TW7001 + E35065