

no longer available - archive entry Alternative article: OU5085

When selecting an alternative article and accessories please note that technical data may differ!

efector200

OU5027



OUN-HNKG

Photoelectric sensors

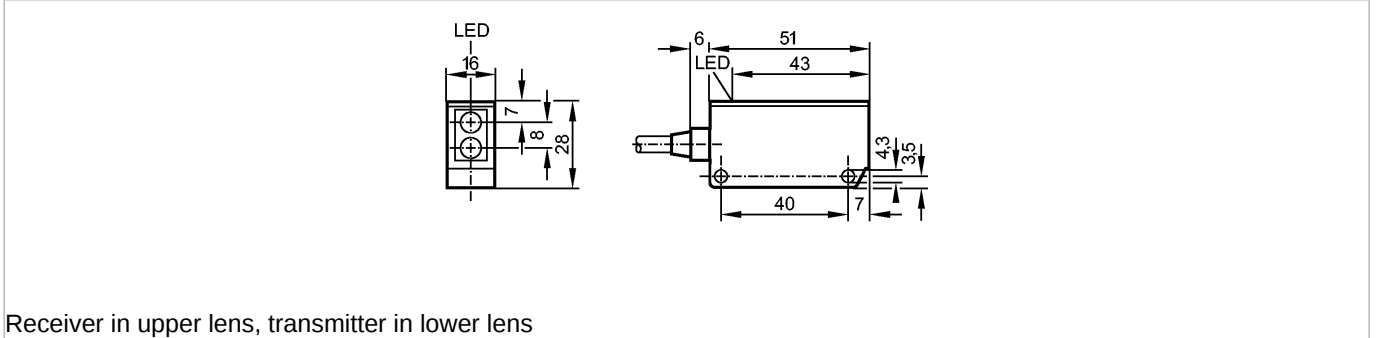

Receiver in upper lens, transmitter in lower lens



Product characteristics

Diffuse reflection sensor

Rectangular, plastics

Cable

Short ranges

Range 20...40mm (referred to white paper 200 x 200 mm)

Electrical data

Electrical design

DC NPN

Operating voltage [V]

10...55 DC

Current consumption [mA]

35 (24 V)

Type of light

Infrared light 880 nm

Protection class

II

Reverse polarity protection

yes

Outputs

Output function

light-on mode

Voltage drop [V]

< 2.5

Current rating [mA]

250

Short-circuit protection

yes (non-latching)

Overload protection

yes

Switching frequency [Hz]

160

Monitoring range

Range [mm]

20...40 (referred to white paper 200 x 200 mm)

Light spot diameter [mm]

20 (at maximum range)

Excess gain graphs

OU5027 - Diffuse reflection sensor - eclass: 27270903 / 27-27-09-03

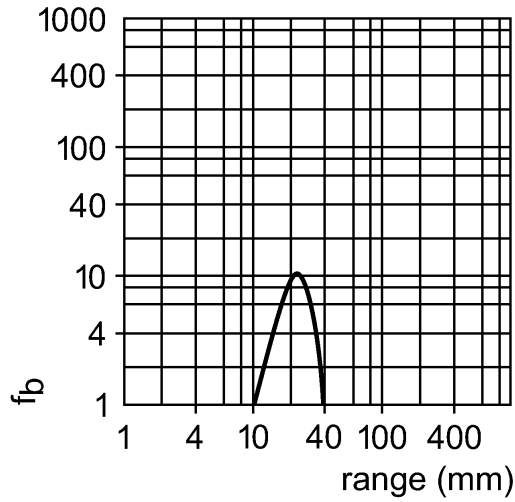

Environment		
Ambient temperature	[°C]	-25...80
Protection		IP 67
Tests / approvals		
EMC		EN 60947-5-2
Mechanical data		
Housing materials		modified PPO
Lens material		glass
Weight	[kg]	0.161
Displays / operating elements		
Output status indication	LED	yellow
Electrical connection		
Connection		PVC cable / 2 m; 3 x 0.34 mm ²

Wiring

Core colors

- BN brown
- BU blue
- BK black

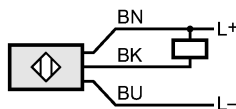

Accessories		
Accessories (included)		Angle bracket; E20211
Remarks		
Pack quantity	[piece]	1

ifm efector, inc. • 1100 Atwater Drive • Malvern • PA 19355 — We reserve the right to make technical alterations without prior notice. — US — OU5027 — 06.03.2003
 no longer available - archive entry Alternative article: OU5085

When selecting an alternative article and accessories please note that technical data may differ!